

ENGINE TYPE-APPROVAL DATA PLATE

Fig.	P/n	QTY	Name
------	-----	-----	------

Notes:

[KRYPTON³ 110 SIX]

1	0.000.0000.1		cannot be supplied MADE BY TREVIGLIO ITALY
2	0.000.0000.1		cannot be supplied MADE AT RANIPET - INDIA



9_STA000_00_0-A-001

CRANKCASE

Fig.	P/n	QTY	Name
------	-----	-----	------

Notes:

FOR ENGINES PRODUCED IN : TREVIGLIO ITALY [KRYPTON³ 110 SIX]



3	2.3199.312.2/20	1	plug m 35x1.5x9.5
5	2.0439.279.7	8	stud bolt m 8 p.1 x 25
6	2.1559.188.2	4	bush 11.4 x 14 x16
7	2.1539.259.0	8	special oil seal 107.62x2.62
8	2.1560.010.0	1	gasket 14.2 x 20
9	2.3199.292.0	1	plug 1/4" gas
10	0.014.9655.4/30	1	crankcase
10.1	2.3130.001.1	14	plug 1/8" gas
10.2	2.3130.002.1	4	plug 1/4" gas
10.3	2.3130.003.1	6	plug 3/8" gas
10.4.1.1.1	0.065.1112.7/10	1	support
10.4.1.2	2.1699.165.0	1	bush 12.3x15x16
10.4.2	0.065.1114.0/10	3	support
10.4.3	0.065.1116.3	1	support
10.4.3.2	2.1699.165.0	1	bush 12.3x15x16
10.4.8	0.065.1117.0	10	screw m 12 x 100
10.5	2.3179.012.0	1	plug 60
10.6	0.065.1140.0	4	special bushing 59X55X20
10.7	0.065.1141.0	1	special bushing 59X55X30
10.8	0.014.1340.0/10	1	pin mm 85
11	0.066.1152.0/10	4	gasket
13	2.1549.154.2	4	bush 4.8x5.8x16
25	0.013.4946.0/10	1	sprayer nozzle
26	2.3120.101.0	1	plug m 18 p.1.5
28	2.1560.014.0	1	washer 18.2 x 24

CRANKCASE

Fig.	P/n	QTY	Name
------	-----	-----	------

Notes:

FOR ENGINES PRODUCED IN : RANIPET - INDIA [KRYPTON³ 110 SIX]

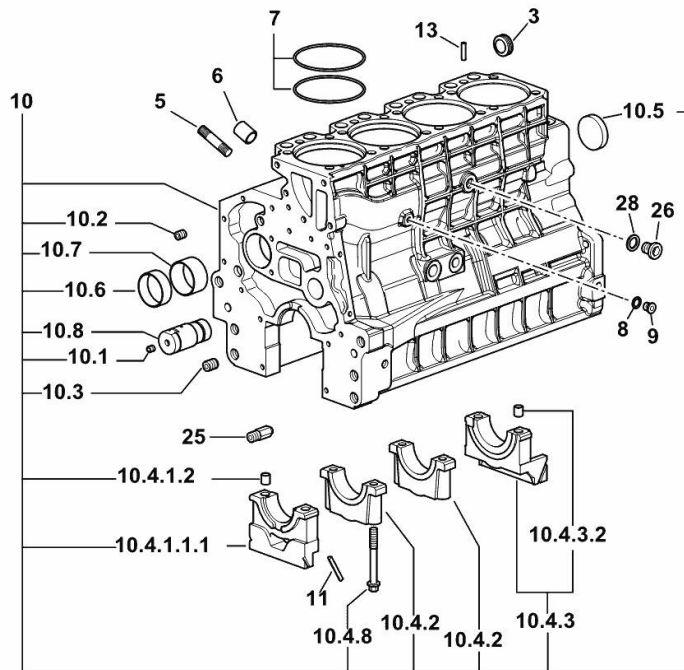

19_O1011_00_0-A-001

3	2.3199.312.2/20	1	plug m 35x1.5x9.5
5	2.0439.279.7	8	stud bolt m 8 p.1 x 25
6	2.1559.188.2	4	bush 11.4 x 14 x16
7	2.1539.259.0	8	special oil seal 107.62x2.62
8	2.1560.010.0	1	gasket 14.2 x 20
9	2.3199.292.0	1	plug 1/4" gas
10	0.014.9655.4/30	1	crankcase
10.1	2.3130.001.1	14	plug 1/8" gas
10.2	2.3130.002.1	4	plug 1/4" gas
10.3	2.3130.003.1	6	plug 3/8" gas
10.4.1.1.1	0.065.1112.7/10	1	support
10.4.1.2	2.1699.165.0	1	bush 12.3x15x16
10.4.2	0.065.1114.0/10	3	support
10.4.3	0.065.1116.3	1	support
10.4.3.2	2.1699.165.0	1	bush 12.3x15x16
10.4.8	0.065.1117.0	10	screw m 12 x 100
10.5	2.3179.012.0	1	plug 60
10.6	0.065.1140.0	4	special bushing 59X55X20
10.7	0.065.1141.0	1	special bushing 59X55X30
10.8	0.014.1340.0/10	1	pin mm 85
11	0.066.1152.0/10	4	gasket
13	2.1549.154.2	4	bush 4.8x5.8x16
25	0.013.4946.0/10	1	sprayer nozzle
26	2.3120.101.0	1	plug m 18 p.1.5
28	2.1560.014.0	1	washer 18.2 x 24

<https://www.ebooklibonline.com>

Hello dear friend!

Thank you very much for reading.

Enter the link into your browser.

The full manual is available for immediate download.

<https://www.ebooklibonline.com>

MONOBLOC ENGINE-GEARBOX CONNECTING FLANGE

Fig.	P/n	QTY	Name
------	-----	-----	------

Notes:

FOR ENGINES PRODUCED IN : TREVIGLIO ITALY [KRYPTON³ 110 SIX]

6	2.0439.250.7	1	stud bolt m 12 / m 10 x 30
7	0.011.9294.0/10	1	bush
30	2.0112.511.2	8	screw m 14 p.2 x 30
31	2.1651.912.0	2	cylindrical plug 12x28
32	2.1651.917.0	1	cylindrical plug 12x40
33	2.0432.257.7	1	stud bolt m 12 p.1.75 - 1.25 x 30
34	0.013.3120.0	1	flange

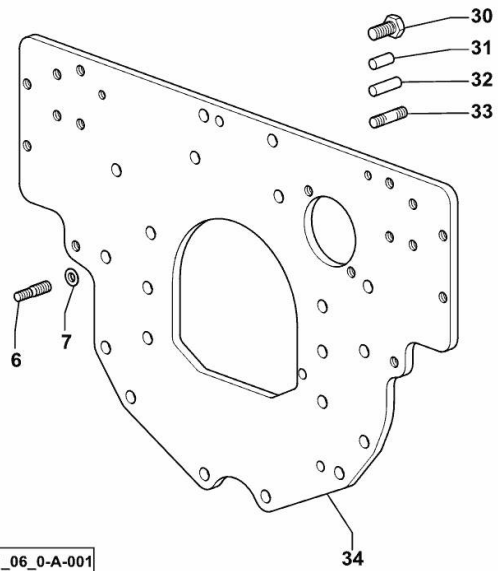

9_32311_06_0-A-001

MONOBLOC ENGINE-GEARBOX CONNECTING FLANGE

Fig.	P/n	QTY	Name
------	-----	-----	------

Notes:

FOR ENGINES PRODUCED IN : RANIPET - INDIA [KRYPTON³ 110 SIX]

6	2.0439.250.7	1	stud bolt m 12 / m 10 x 30
7	0.011.9294.0/10	1	bush
30	2.0112.511.2	8	screw m 14 p.2 x 30
31	2.1651.912.0	2	cylindrical plug 12x28
32	2.1651.917.0	1	cylindrical plug 12x40
33	2.0432.257.7	1	stud bolt m 12 p.1.75 - 1.25 x 30
34	0.013.3120.0	1	flange

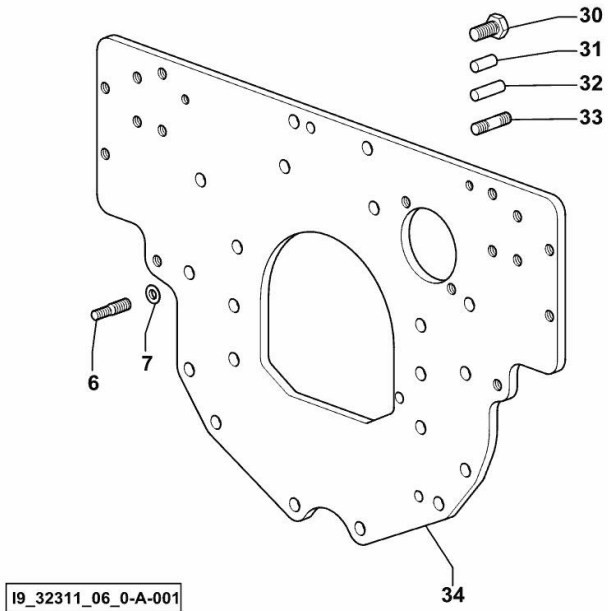

ENGINE OIL AND TURBO PRESSURE SWITCH UNION

Fig.	P/n	QTY	Name
------	-----	-----	------

Notes:

FOR ENGINES PRODUCED IN : TREVIGLIO ITALY [KRYPTON³ 110 SIX]

10	2.3339.574.2	1	pipe fitting
11	2.3249.014.2	1	pipe fitting m 12 p.1.5
12	2.1560.008.0	4	gasket 12.2 x 18
13	2.3330.003.1	1	pipe union m 12 p.1.5

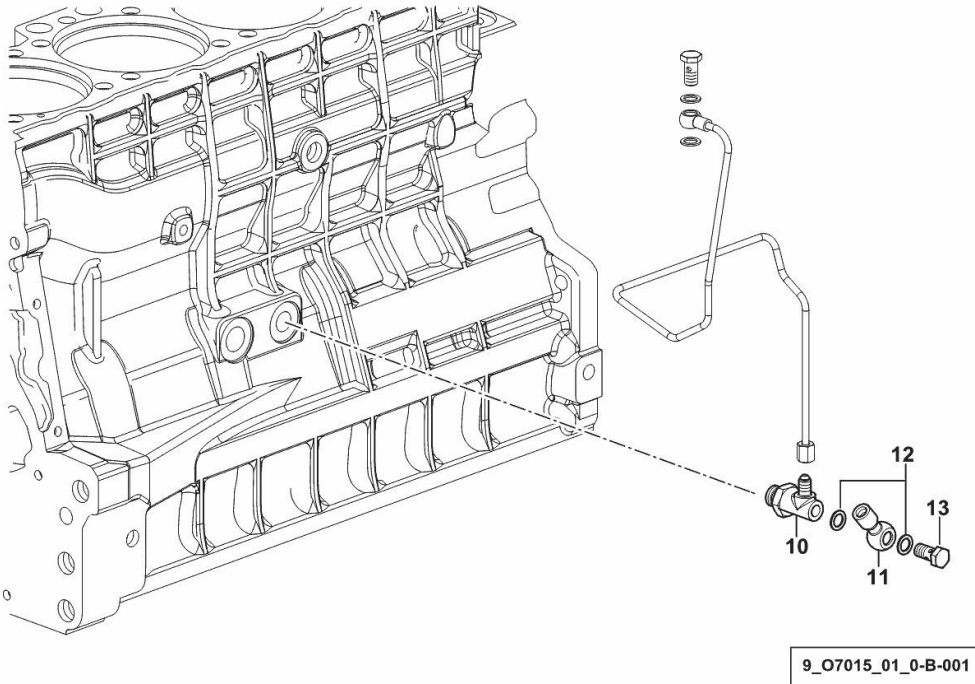

ENGINE OIL AND TURBO PRESSURE SWITCH UNION

Fig.	P/n	QTY	Name
------	-----	-----	------

Notes:

FOR ENGINES PRODUCED IN : RANIPET - INDIA [KRYPTON³ 110 SIX]

10	2.3339.574.2	1	pipe fitting
11	2.3249.014.2	1	pipe fitting m 12 p.1.5
12	2.1560.008.0	4	gasket 12.2 x 18
13	2.3335.005.2	1	pipe union m 12 p.1.5 x 24

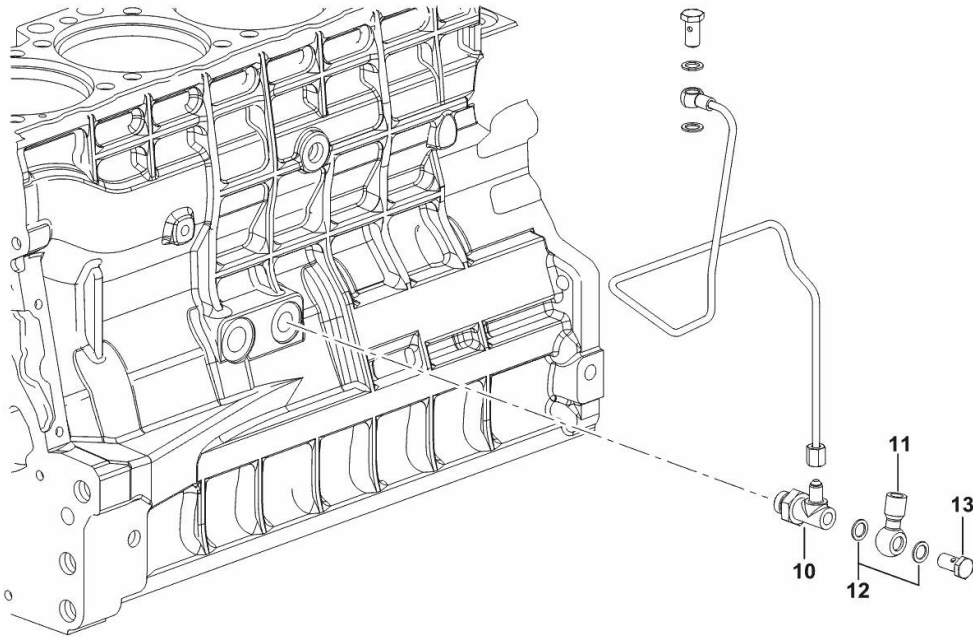

19_K1415_01_0-B-001

SIDE PLUG FOR CYLINDER BLOCK

Fig.	P/n	QTY	Name
------	-----	-----	------

Notes:

FOR ENGINES PRODUCED IN : RANIPET - INDIA [KRYPTON³ 110 SIX]

22	2.1560.017.0	1	gasket 22.2 x 27
23	2.3120.002.4	1	plug m 22 x 1.5

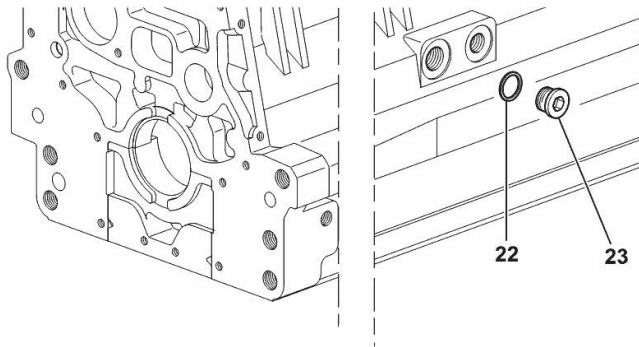

I9_33211_07_0-A-001

LOWER PLUG FOR CYLINDER BLOCKS

Fig.	P/n	QTY	Name
------	-----	-----	------

Notes:

FOR ENGINES PRODUCED IN : TREVIGLIO ITALY [KRYPTON³ 110 SIX]

1	2.3130.003.1	2	plug 3/8" gas
---	--------------	---	---------------

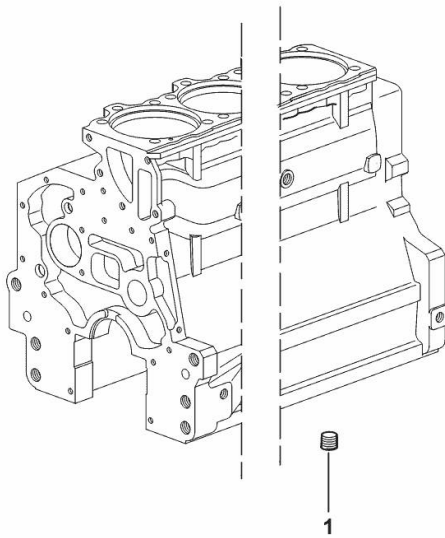

9_33311_06_0-A-001

LOWER PLUG FOR CYLINDER BLOCKS

Fig.	P/n	QTY	Name
------	-----	-----	------

Notes:

FOR ENGINES PRODUCED IN : RANIPET - INDIA [KRYPTON³ 110 SIX]

1	2.3130.003.1	2	plug 3/8" gas
---	--------------	---	---------------

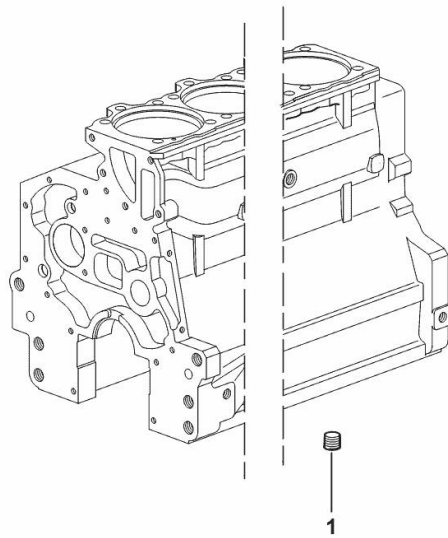

19_37511_06_0-A-001

ENGINE CRANKSHAFT PULLEY WITH RING-FEEDER RINGS

Fig.	P/n	QTY	Name
------	-----	-----	------

Notes:

FOR ENGINES PRODUCED IN : TREVIGLIO ITALY [KRYPTON³ 110 SIX]

1	0.015.6055.0	1	pulley
2	0.011.3515.0/20	1	hub Z = 48
3	0.065.1256.0	2	ring 45x52
4	2.1579.865.0	1	spacer 45.2x51.8x10
5	2.0439.195.7	1	stud bolt m 20 p.1.5x80
6	2.1019.094.7	1	nut m 20 p.1.5
7	2.0112.320.2	6	screw m 10 p.1.5 x 55
8	2.1470.006.2	6	lock washer 10

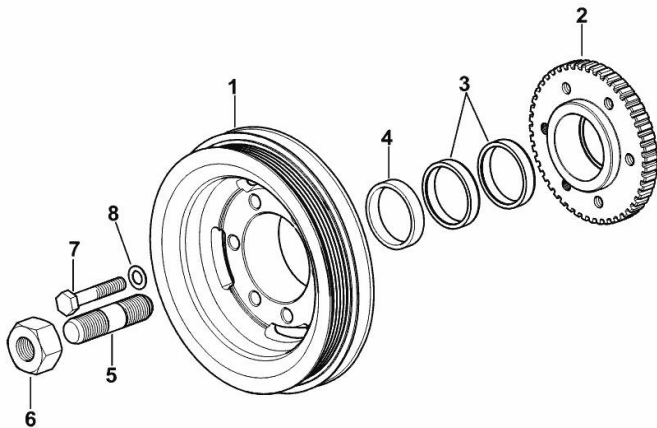

9_O6312_03_0-A-001

ENGINE CRANKSHAFT PULLEY WITH RING-FEEDER RINGS

Fig.	P/n	QTY	Name
------	-----	-----	------

Notes:

FOR ENGINES PRODUCED IN : RANIPET - INDIA [KRYPTON³ 110 SIX]

1	0.015.6055.0	1	pulley
2	0.011.3515.0/20	1	hub Z = 48
3	0.065.1256.0	2	ring 45x52
4	2.1579.865.0	1	spacer 45.2x51.8x10
5	2.0439.195.7	1	stud bolt m 20 p.1.5x80
6	2.1019.094.7	1	nut m 20 p.1.5
7	2.0112.320.2	6	screw m 10 p.1.5 x 55
8	2.1470.006.2	6	lock washer 10

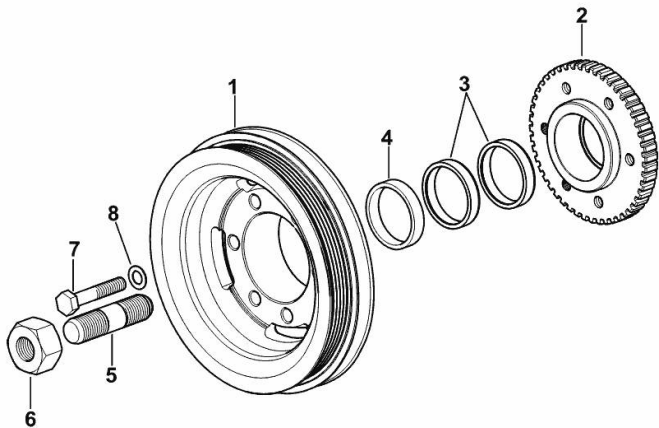

I9_O6312_03_0-A-001

COOLANT PUMP AND ALTERNATOR DRIVEBELT

Fig.	P/n	QTY	Name
------	-----	-----	------

Notes:

[KRYPTON³ 110 SIX]

13	2.4119.188.0	1	belt PV-K5 17.4x1275 mm
----	--------------	---	-------------------------

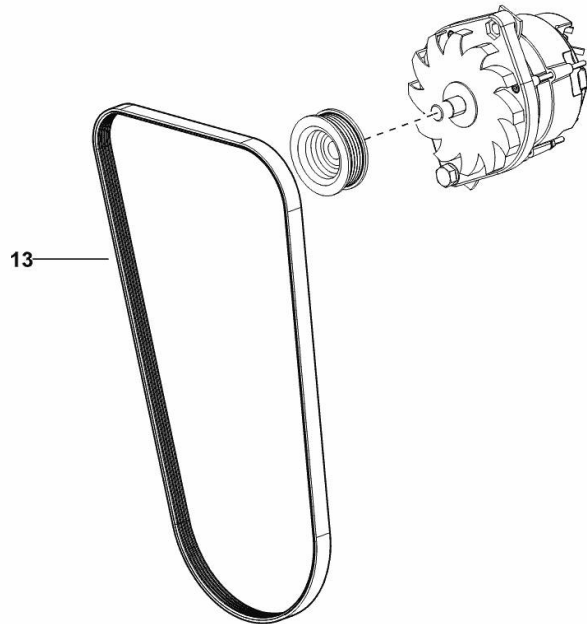

9_W5684_09_0-B-001



Suggest:

For more complete manuals. Please go to the home page.

<https://www.ebooklibonline.com>

If the above button click is invalid. Please download this document first, and then click the above link to download the complete manual.

Thank you so much for reading

CRANKSHAFT

Fig.	P/n	QTY	Name
------	-----	-----	------

Notes:

FOR ENGINES PRODUCED IN : TREVIGLIO ITALY [KRYPTON³ 110 SIX] 10026 <-

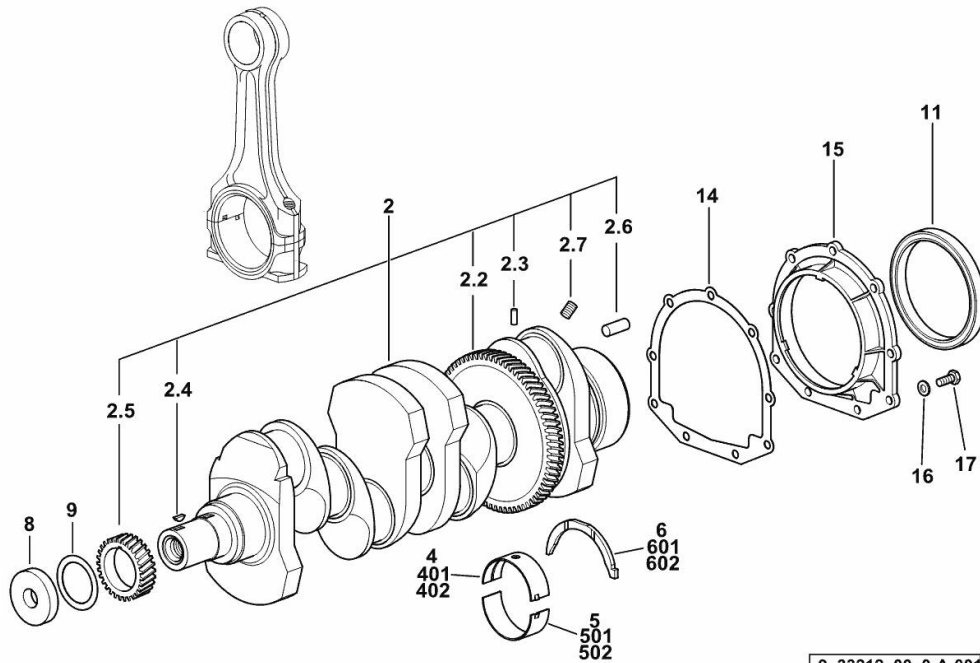

9_33212_00_0-A-001

2	0.086.1210.3/40	1	crankshaft
2.2	0.065.1211.0/10	1	crown wheel
2.3	2.1630.608.0	1	pin 6x16
2.4	2.1720.006.0	1	key 4x6.5
2.5	0.065.1323.0/30	1	gear Z = 29
2.6	2.1651.915.0	1	pin 12x35
2.7	2.3130.001.1	4	plug 1/8" gas
4	0.065.1215.0/10	5	main half bushing STANDARD
5	0.065.1216.0/10	5	main half bushing STANDARD
6	0.065.1218.0	4	shim STANDARD
8	2.1599.524.7	1	washer 21x60x12
9	2.1589.189.0	2	shoulder ring mm 1.00
11	2.1529.073.0	1	special oil seal 110x130x13
14	0.065.1254.0/20	1	gasket
15	0.007.1711.0/10	1	cover
16	2.1475.002.2	9	conical washer 8
17	2.0112.207.2	9	screw m 8 p 1.25 x 20
401	0.065.1215.7		main half bushing - mm 0.25
402	0.065.1215.8		main half bushing - mm 0.50
501	0.065.1216.7		main half bushing - mm 0.25
502	0.065.1216.8		main half bushing - mm 0.50
601	0.065.1218.7		shim + mm 0.10
602	0.065.1218.8		shim + mm 0.15

CRANKSHAFT

Fig.	P/n	QTY	Name
------	-----	-----	------

Notes:

FOR ENGINES PRODUCED IN : TREVIGLIO ITALY [KRYPTON³ 110 SIX]

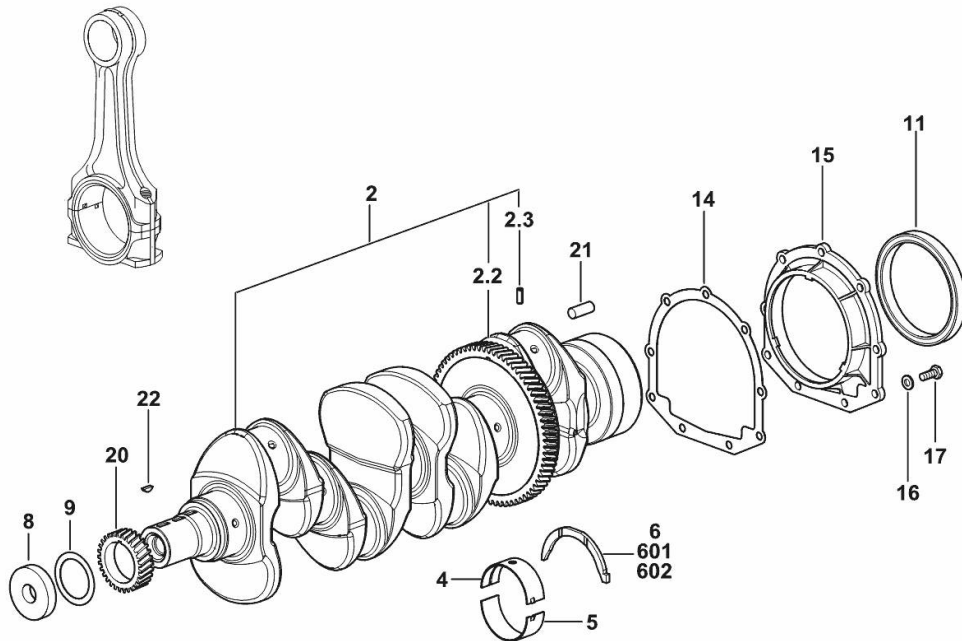

2	0.021.8246.3	1	crankshaft
2.2	0.065.1211.0/10	1	crown wheel
2.3	2.1630.608.0	1	pin 6x16
4	0.019.5455.0	5	main half bushing STANDARD
5	0.019.5456.0	5	main half bushing STANDARD
6	0.065.1218.0	4	shim STANDARD
8	2.1599.524.7	1	washer 21x60x12
9	2.1589.189.0	2	shoulder ring mm 1.00
11	2.1529.073.0	1	special oil seal 110x130x13
14	0.065.1254.0/20	1	gasket
15	0.007.1711.0/10	1	cover
16	2.1475.002.2	9	conical washer 8
17	2.0112.207.2	9	screw m 8 p 1.25 x 20
20	0.065.1323.0/30	1	gear Z = 29
21	2.1651.915.0	1	pin 12x35
22	2.1720.006.0	1	key 4x6.5
601	0.065.1218.7		shim + mm 0.10
602	0.065.1218.8		shim + mm 0.15

9_33212_00_0-A-002

<https://www.ebooklibonline.com>

Hello dear friend!

Thank you very much for reading.

Enter the link into your browser.

The full manual is available for immediate download.

<https://www.ebooklibonline.com>