

Section: B0 - ENGINE

CRANKCASE

Fig.	P/n	QTY	Name
------	-----	-----	------

Notes:

[KRYPTON F 90 M] [KRYPTON F 90 N] [KRYPTON F 90 C]

3	2.3199.312.2/20	1	plug m 35x1.5x9.5
5	2.0439.273.7	8	stud bolt m 8
6	2.1559.188.2	4	bush 11.4 x 14 x16
7	2.1539.259.0	8	special oil seal 107.62x2.62
8	2.1560.010.0	1	gasket 14.2 x 20
9	2.3199.292.0	1	plug 1/4" gas
11	0.066.1152.0/10	4	gasket
13	2.1549.154.2	4	bush 4.8x5.8x16
14	0.015.2988.4/10	1	crankcase
14.1	2.3130.001.1	10	plug 1/8" gas
14.2	2.3130.002.1	2	plug 1/4" gas
14.3	2.3130.003.1	6	plug 3/8" gas
14.4.1.1.1	0.065.1112.7/10	1	support
14.4.1.2	2.1699.165.0	1	bush 12.3x15x16
14.4.2	0.065.1114.0/10	3	support
14.4.3	0.065.1116.3	1	support
14.4.3.2	2.1699.165.0	1	bush 12.3x15x16
14.4.5	0.065.1117.0	10	screw m 12 x 100
14.5	2.3179.012.0	1	plug 60
14.6	0.065.1140.0	4	special bushing 59X55X20
14.7	0.065.1141.0	1	special bushing 59X55X30
14.8	0.014.1340.0/10	1	pin mm 85
25	0.013.4946.0/10	1	sprayer nozzle
26	2.3120.101.0	1	plug m 18 p.1.5
28	2.1560.014.0	1	washer 18.2 x 24

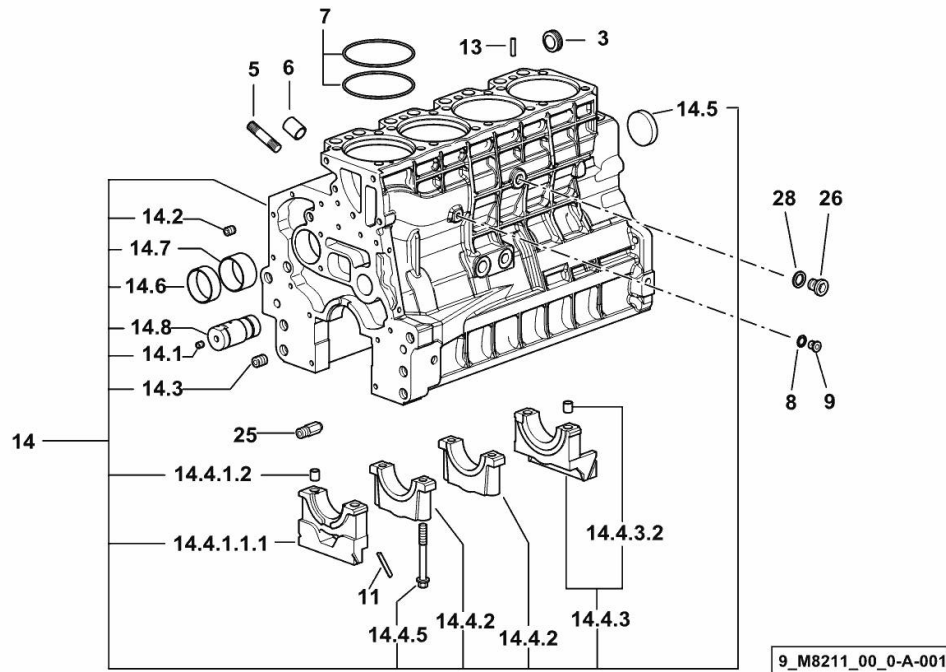

MONOBLOC ENGINE-GEARBOX CONNECTING FLANGE

Fig.	P/n	QTY	Name
------	-----	-----	------

Notes:

[KRYPTON F 90 M] [KRYPTON F 90 N] [KRYPTON F 90 C]

6	2.0439.250.7	1	stud bolt m 12 / m 10 x 30
7	0.011.9294.0/10	1	bush
30	2.0112.511.2	8	screw m 14 p.2 x 30
31	2.1651.912.0	2	cylindrical plug 12x28
32	2.1651.917.0	1	cylindrical plug 12x40
33	2.0432.257.7	1	stud bolt m 12 p.1.75 - 1.25 x 30
34	0.013.3120.0	1	flange

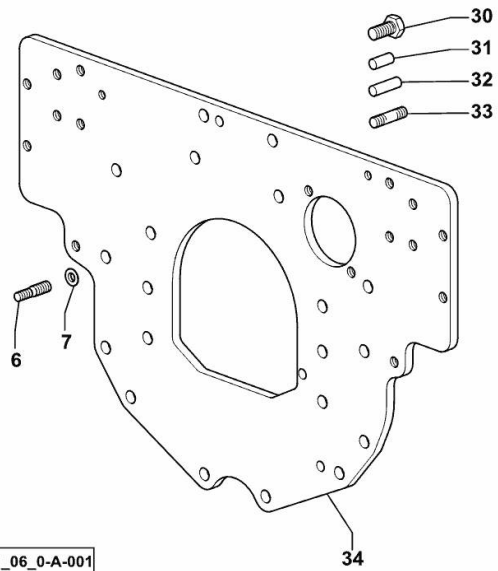

PLUG

Fig.	P/n	QTY	Name
------	-----	-----	------

Notes:

[KRYPTON F 90 M] [KRYPTON F 90 N] [KRYPTON F 90 C]

1	2.3130.003.1	1	plug 3/8" gas
---	--------------	---	---------------

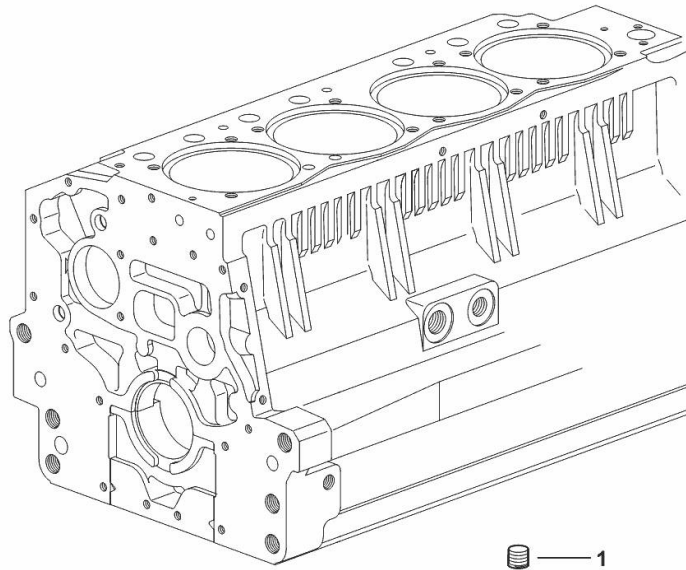

1

9_34311_06_0-A-001

<https://www.ebooklibonline.com>

Hello dear friend!

Thank you very much for reading.

Enter the link into your browser.

The full manual is available for immediate download.

<https://www.ebooklibonline.com>

CRANKSHAFT

Fig.	P/n	QTY	Name
------	-----	-----	------

Notes:

[KRYPTON F 90 M] 1170 <- [KRYPTON F 90 N] 1170 <- [KRYPTON F 90 C] 1170 <-

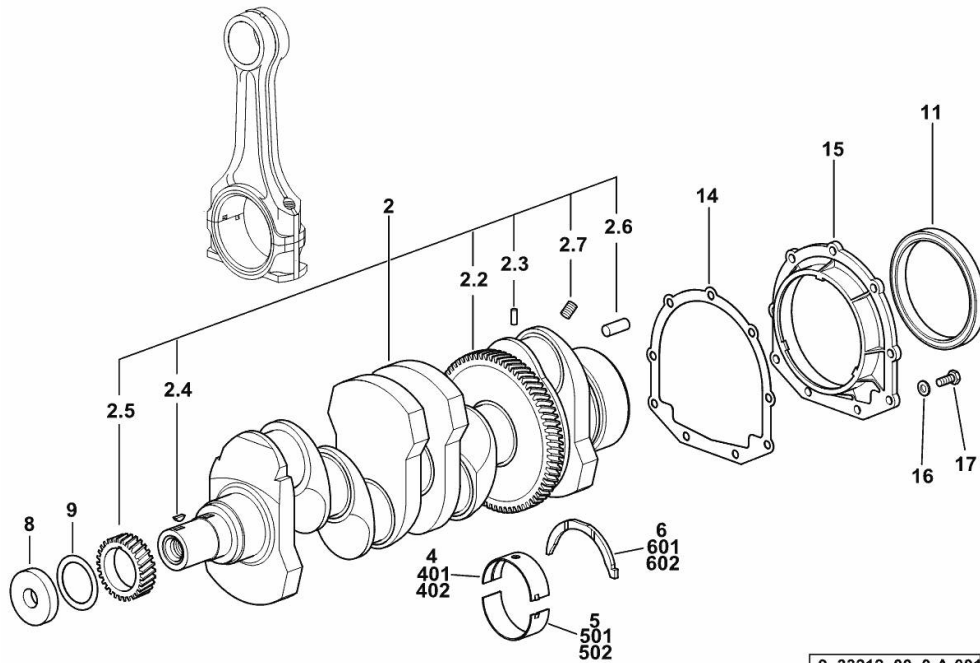

9_33212_00_0-A-001

2	0.086.1210.3/40	1	crankshaft
2.2	0.065.1211.0/10	1	crown wheel
2.3	2.1630.608.0	1	pin 6x16
2.4	2.1720.006.0	1	key 4x6.5
2.5	0.065.1323.0/30	1	gear Z = 29
2.6	2.1651.915.0	1	pin 12x35
2.7	2.3130.001.1	4	plug 1/8" gas
4	0.065.1215.0/10	5	main half bushing STANDARD
5	0.065.1216.0/10	5	main half bushing STANDARD
6	0.065.1218.0	4	shim STANDARD
8	2.1599.524.7	1	washer 21x60x12
9	2.1589.189.0	2	shoulder ring mm 1.00
11	2.1529.073.0	1	special oil seal 110x130x13
14	0.065.1254.0/20	1	gasket
15	0.007.1711.0/10	1	cover
16	2.1475.002.2	9	conical washer 8
17	2.0112.207.2	9	screw m 8 p 1.25 x 20
401	0.065.1215.7		main half bushing - mm 0.25
402	0.065.1215.8		main half bushing - mm 0.50
501	0.065.1216.7		main half bushing - mm 0.25
502	0.065.1216.8		main half bushing - mm 0.50
601	0.065.1218.7		shim + mm 0.10
602	0.065.1218.8		shim + mm 0.15

CRANKSHAFT

Fig.	P/n	QTY	Name
------	-----	-----	------

Notes:

[KRYPTON F 90 M] [KRYPTON F 90 N] [KRYPTON F 90 C]

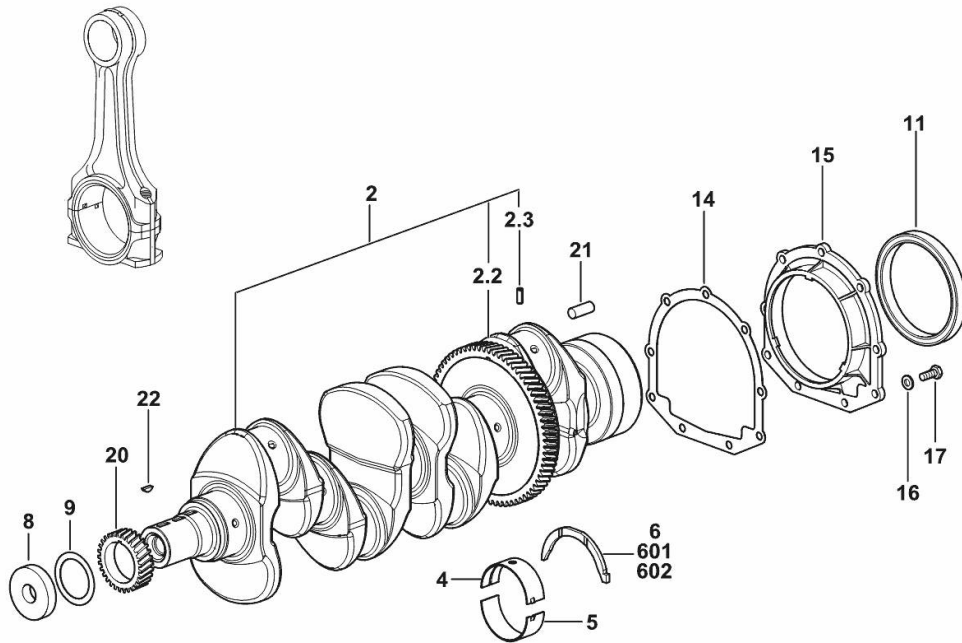

2	0.021.8246.3	1	crankshaft
2.2	0.065.1211.0/10	1	crown wheel
2.3	2.1630.608.0	1	pin 6x16
4	0.019.5455.0	5	main half bushing STANDARD
5	0.019.5456.0	5	main half bushing STANDARD
6	0.065.1218.0	4	shim STANDARD
8	2.1599.524.7	1	washer 21x60x12
9	2.1589.189.0	2	shoulder ring mm 1.00
11	2.1529.073.0	1	special oil seal 110x130x13
14	0.065.1254.0/20	1	gasket
15	0.007.1711.0/10	1	cover
16	2.1475.002.2	9	conical washer 8
17	2.0112.207.2	9	screw m 8 p 1.25 x 20
20	0.065.1323.0/30	1	gear Z = 29
21	2.1651.915.0	1	pin 12x35
22	2.1720.006.0	1	key 4x6.5
601	0.065.1218.7		shim + mm 0.10
602	0.065.1218.8		shim + mm 0.15

9_33212_00_0-A-002

CRANKSHAFT PULLEY

Fig.	P/n	QTY	Name
------	-----	-----	------

Notes:

[KRYPTON F 90 M] [KRYPTON F 90 N] [KRYPTON F 90 C]

3	0.013.7208.0/10	1	pulley OUTSIDE DIAMETER 192 mm
5	0.085.1248.0/20	1	hub
6	2.0399.144.7/10	1	screw m 20 p.1.5x51
8	2.1720.006.0	1	key 4x6.5

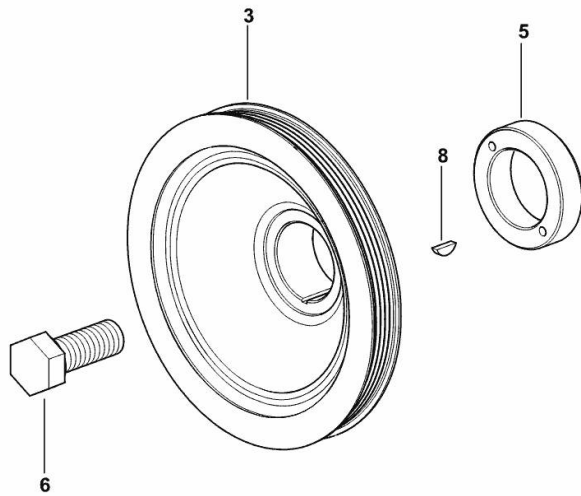

9_N4612_01_0-A-001

COOLANT PUMP AND ALTERNATOR DRIVEBELT

Fig.	P/n	QTY	Name
------	-----	-----	------

Notes:

[KRYPTON F 90 M] [KRYPTON F 90 N] [KRYPTON F 90 C]

1	2.4119.188.0	1	belt PV-K5 17.4x1275 mm
---	--------------	---	-------------------------

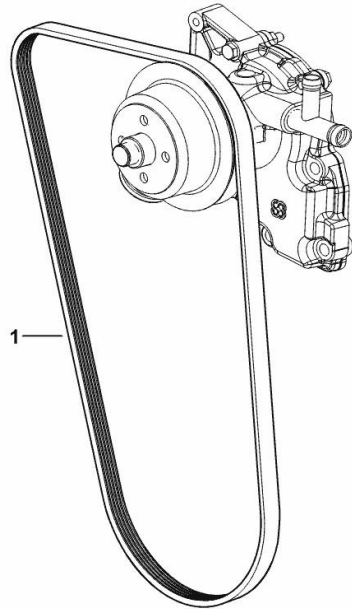

9_N1817_09_0-A-001

ENGINE FLYWHEEL

Fig.	P/n	QTY	Name
------	-----	-----	------

Notes:

[KRYPTON F 90 M] [KRYPTON F 90 N] [KRYPTON F 90 C]

55	0.066.1247.3/30	1	flywheel
55.2	0.065.1242.0	1	crown wheel Z = 123
56	0.255.2525.0/10	1	flange
57	2.0139.022.2	6	screw m 12 p.1.25x55

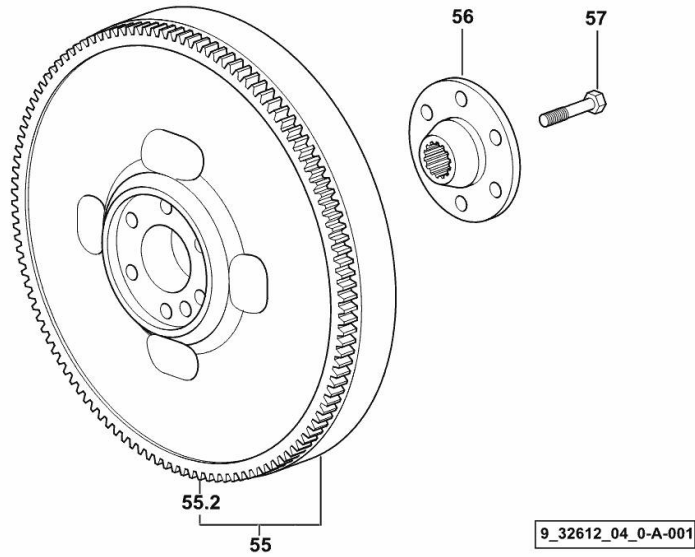

9_32612_04_0-A-001

Section: B0 - ENGINE
COUNTERWEIGHTS

Fig.	P/n	QTY	Name
------	-----	-----	------

Notes:

[KRYPTON F 90 M] [KRYPTON F 90 N] [KRYPTON F 90 C]

25	2.1589.139.0	1	shoulder ring mm 0.3
26	2.1589.140.0	3	shoulder ring mm 0.1
29	2.1579.628.0	3	spacer 16.5x26x0.1
33	2.1579.629.0	6	spacer 12.5x26x0.1
34	2.1589.048.0	1	shoulder ring 16.5x26x0.3
35	2.1589.049.0	1	shoulder ring 12.5x26x0.3
38.1.1	0.086.1231.0/10	1	box
38.1.2	2.3130.001.1	4	plug 1/8" gas
38.2	0.086.1233.3/30	1	mass sx/lh/li
38.2.2	2.1559.115.0	2	special bushing 26x30x30
38.2.99.4	2.1651.302.0	1	roll pin 4x6
38.3	0.065.1233.3/30	1	mass dx/rh/re
38.3.2	2.1559.115.0	2	special bushing 26x30x30
38.3.99.4	2.1651.302.0	1	roll pin 4x6
38.3.99.5	2.1410.018.7	1	circlip 45
38.4.1	0.065.1234.0/10	1	shaft
38.4.2	2.3130.001.1	1	plug 1/8" gas
38.5	2.1631.717.0	2	roll pin 8 x 40
38.6	2.1589.185.0	4	shoulder ring 26.1x34x1
38.7	2.0522.212.7	1	screw m 8 p.1.25 x 30
44	2.1579.626.0	2	spacer 13.2x16x11
45	2.0139.028.2	4	screw m 12
46	2.1699.191.0	1	bush 7x10x16

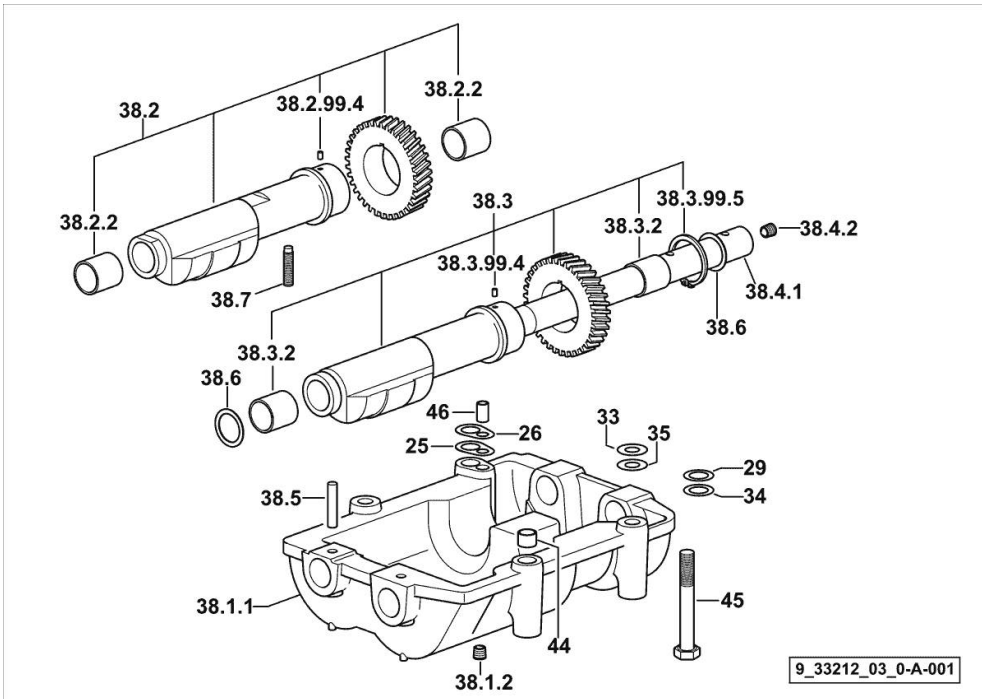



Suggest:

For more complete manuals. Please go to the home page.

<https://www.ebooklibonline.com>

If the above button click is invalid. Please download this document first, and then click the above link to download the complete manual.

Thank you so much for reading

CYLINDER - PISTON - CONNECTING ROD

Fig.	P/n	QTY	Name
------	-----	-----	------

Notes:

[KRYPTON F 90 M] [KRYPTON F 90 N] [KRYPTON F 90 C]

1	0.099.0065.A	4	cyl. piston assembly "A" - CLASS A
1	0.099.0065.B	4	cyl. piston assembly "B" - CLASS B
1.2	0.A12.2675.0	1	engine cylinder "A" - CLASS A
1.2	0.B12.2675.0	1	engine cylinder "B" - CLASS B
1.3	0.099.0060.A	1	complete piston "A" - CLASS A
1.3	0.099.0060.B	1	complete piston "B" - CLASS B
1.3.1	0.081.0090.6/10	1	piston ring set
1.3.2	2.1411.014.1	2	circlip 35
1.3.3	0.078.1236.0	1	piston pin Ø 18 / Ø 35 / L = mm 86
2	0.078.1220.3/30	4	engine connecting rod
2.1	2.1559.114.0/10	1	special bushing
2.2	2.0399.213.0	2	screw m 12 p.1.25x61.5
3	0.065.1225.0	8	con.rod half bushing STANDARD - A = 28.75 -> 29.00
3	0.065.1225.7	8	con.rod half bushing - mm 0.25
3	0.065.1225.8	8	con.rod half bushing - mm 0.50

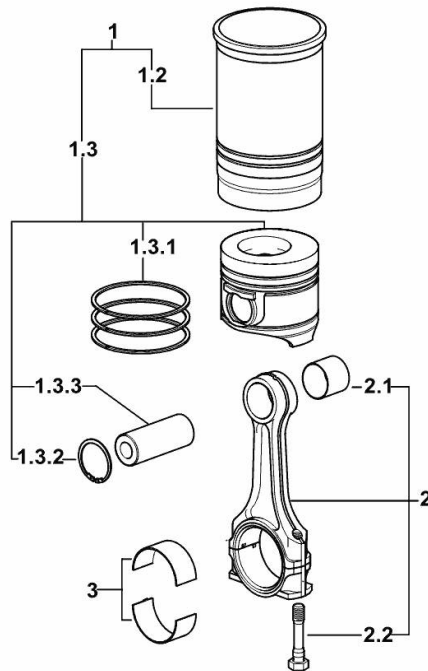

9_M5212_01_M-A-001

GUARD PLATE

Fig.	P/n	QTY	Name
------	-----	-----	------

Notes:

[KRYPTON F 90 M] [KRYPTON F 90 N] [KRYPTON F 90 C]

1	0.007.1262.3/50	1	guard
2	0.007.1271.0/10	1	small column m 8 p.1.25 / L = mm 60
3	0.007.1272.0/10	2	small column m 8 p.1.25 / L = mm 50
5	2.1310.004.2	3	flat washer 8.4x17
7	2.0112.203.2	3	screw m 8 p.1.25 x 12

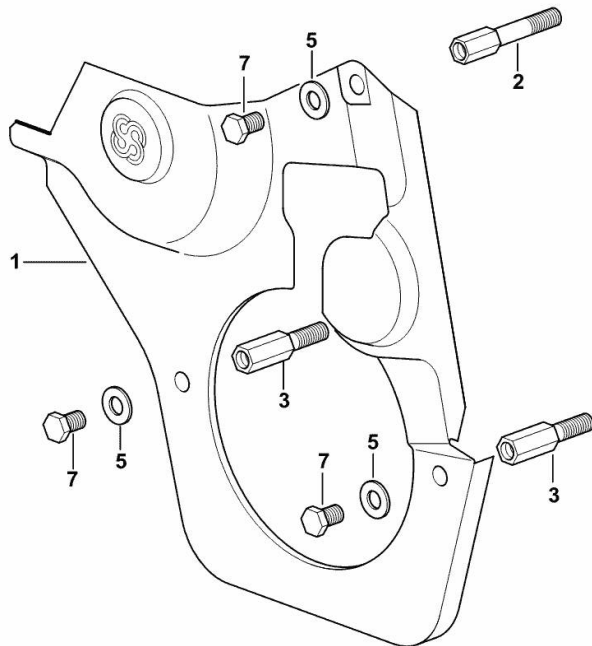

9_33011_02_0-A-001

<https://www.ebooklibonline.com>

Hello dear friend!

Thank you very much for reading.

Enter the link into your browser.

The full manual is available for immediate download.

<https://www.ebooklibonline.com>