

Section: ENGINE
CRANKCASE

9_33211_00_0_A

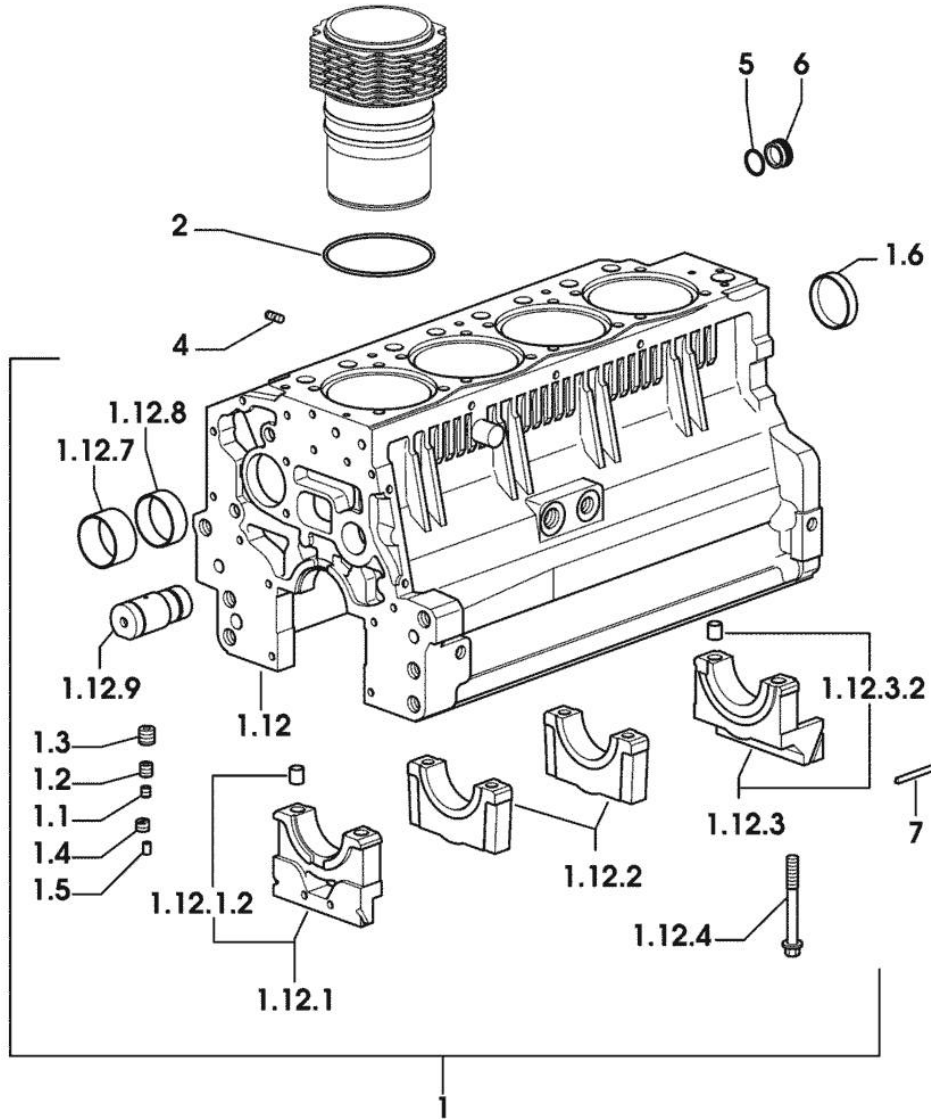

Fig.	P/n	QTY	Name
------	-----	-----	------

Notes:
 [KRYPTON 80]

1	0.007.1140.6/10	1	crankcase
1.1	2.3130.001.1	11	plug 1/8" gas
1.2	2.3130.002.1	2	plug 1/4" gas
1.3	2.3130.003.1	7	plug 3/8" gas
1.4	2.1324.011.0	1	plug
1.5	2.3199.092.0	4	plug 8 x 12
1.6	2.3179.012.0	1	plug 60
1.12	0.000.0000.1		cannot be supplied
1.12.1	0.065.1112.7	1	support
1.12.1.2	2.1699.165.0	1	bush 12.3x15x16
1.12.2	0.065.1114.0/10	3	support
1.12.3	0.065.1116.3	1	support
1.12.3.2	2.1699.165.0	1	bush 12.3x15x16
1.12.4	0.065.1117.0	10	screw m 12 x 100
1.12.7	0.065.1141.0	1	special bushing 59X55X30
1.12.8	0.065.1140.0	4	special bushing 59X55X20
1.12.9	0.066.1151.0	1	pin
2	2.1539.130.0/10	4	special oil seal 117.07x3.53
4	2.0432.003.7	12	stud bolt m 8 p.1.25 / p.1 x 20
5	2.1532.072.0	1	oil seal 26.70x1.78
6	2.3199.405.2	1	plug m 28 p.1.5
7	0.066.1152.0/10	4	gasket

SIDE PLUG FOR CYLINDER BLOCK

Fig.	P/n	QTY	Name
------	-----	-----	------

Notes:
[KRYPTON 80]

22	2.1560.017.0	1	gasket 22.2 x 27
23	2.3120.002.4	1	plug m 22 x 1.5

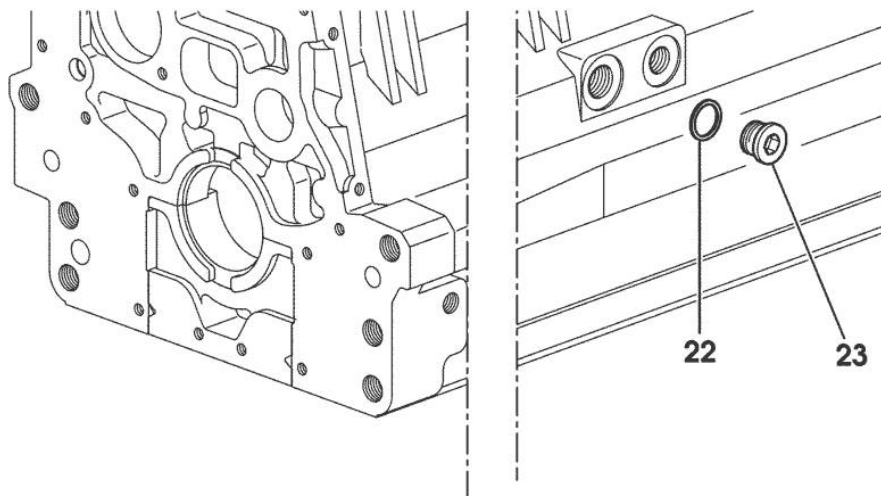

9_33211_07_0_0

FLANGE

Fig.	P/n	QTY	Name
------	-----	-----	------

Notes:
[KRYPTON 80]

6	2.0439.250.7	1	stud bolt m 12 / m 10 x 30
7	0.011.9294.0/10	1	bush
30	2.0112.511.2	8	screw m 14 p.2 x 30
31	2.1651.912.0	2	cylindrical plug 12x28
32	2.1651.917.0	1	cylindrical plug 12x40
33	2.0432.257.7	1	stud bolt m 12 p.1.75 - 1.25 x 30
34	0.013.3120.0	1	flange

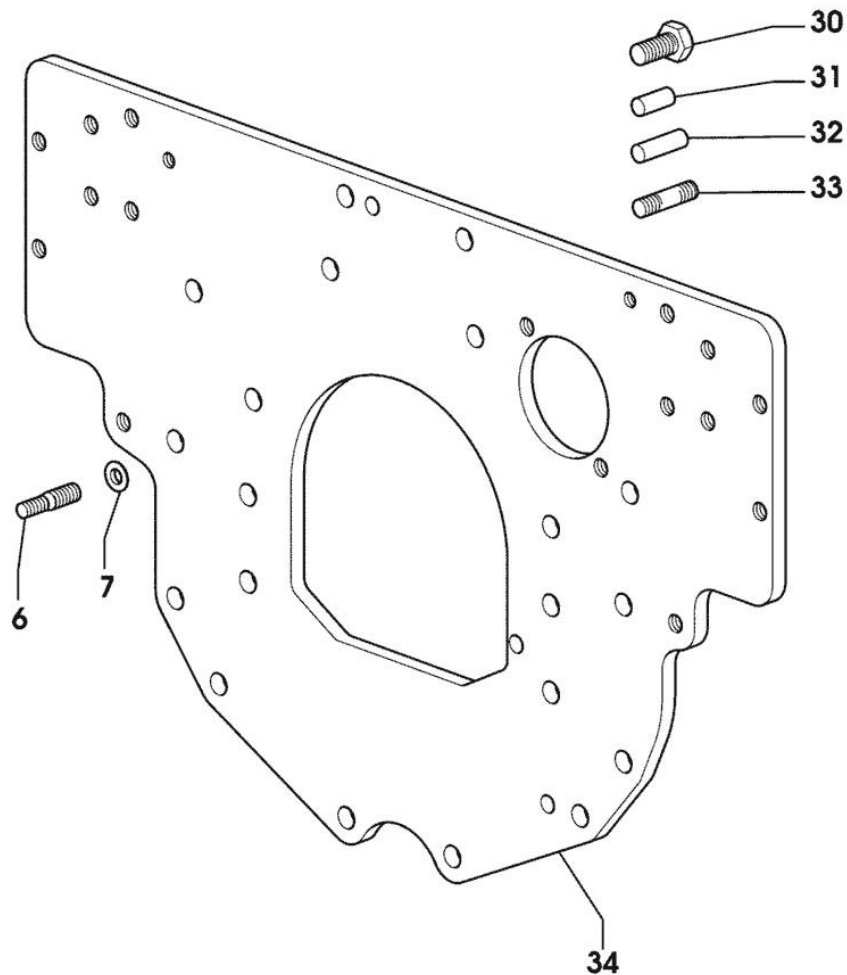

9_32311_06_0_0

<https://www.ebooklibonline.com>

Hello dear friend!

Thank you very much for reading.

Enter the link into your browser.

The full manual is available for immediate download.

<https://www.ebooklibonline.com>

Section: ENGINE
GUARD PLATE

Fig.	P/n	QTY	Name
------	-----	-----	------

Notes:
 [KRYPTON 80]

1	0.007.1262.3/50	1	guard
2	0.007.1271.0/10	1	small column m 8 p.1.25 / L = mm 60
3	0.007.1272.0/10	2	small column m 8 p.1.25 / L = mm 50
5	2.1310.004.2	3	flat washer 8.4x17
7	2.0112.203.2	3	screw m 8 p.1.25 x 12

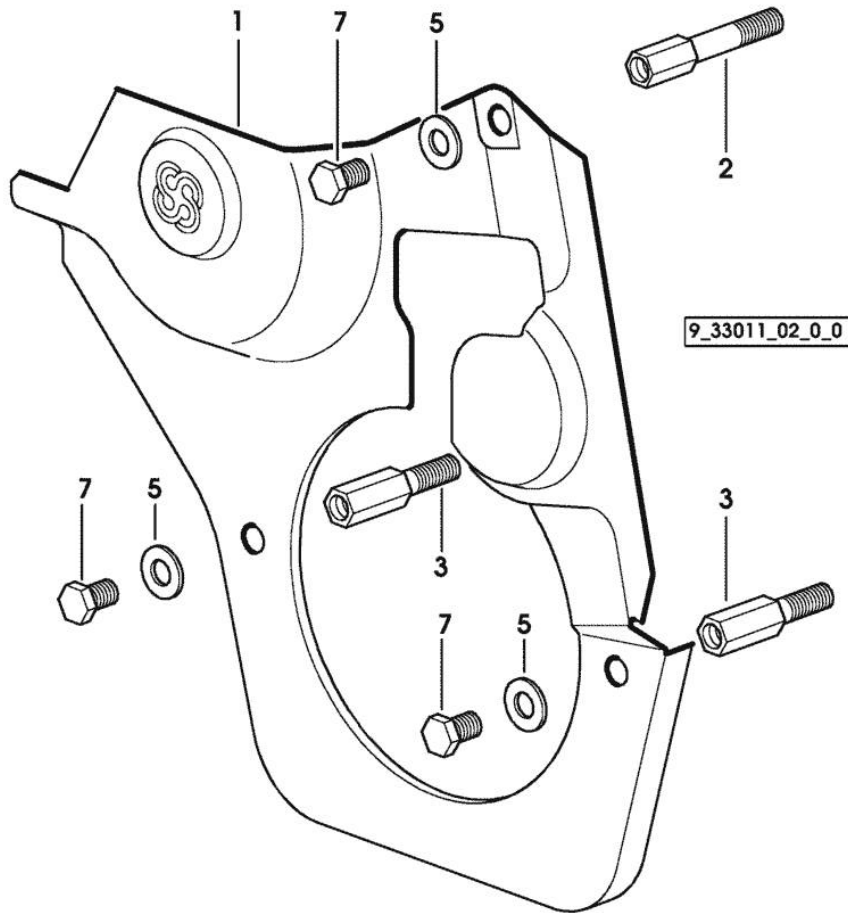

TIMING CASE

9_33211_00_0_B

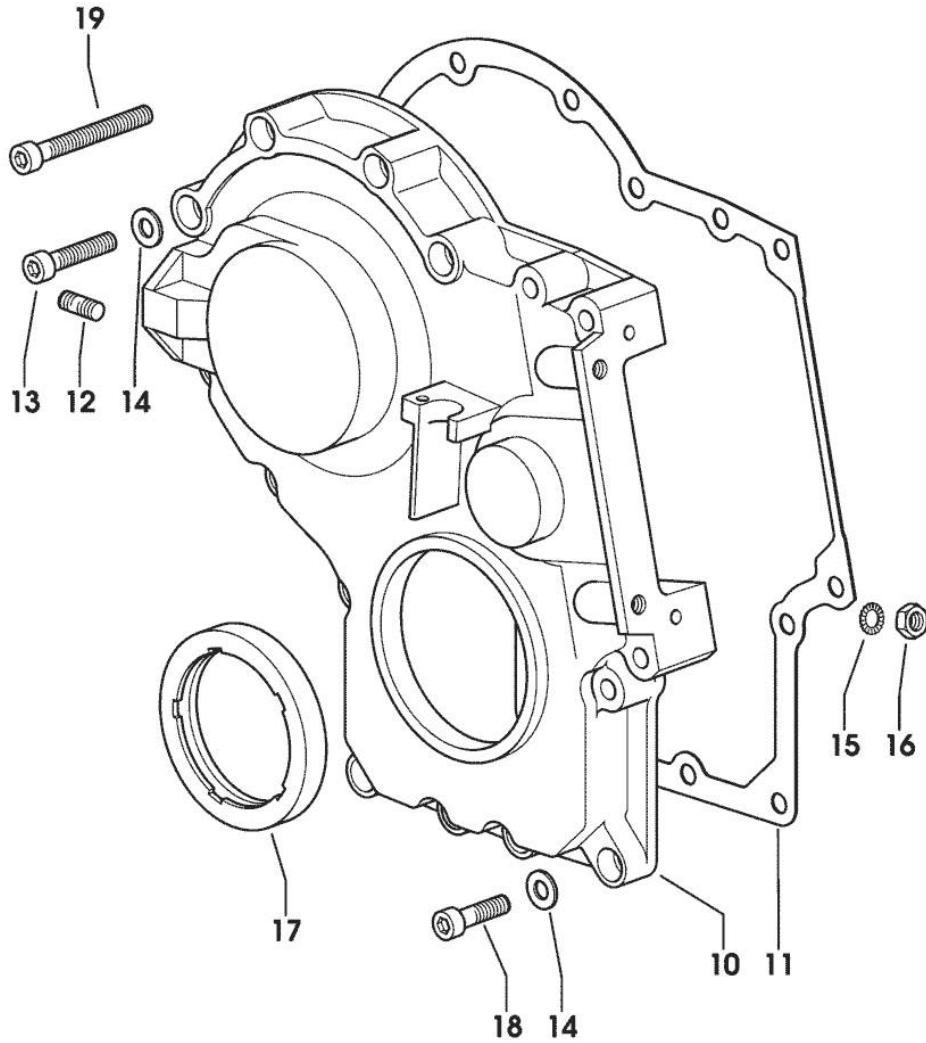

Fig.	P/n	QTY	Name
------	-----	-----	------

Notes:
[KRYPTON 80]

10	0.065.1132.0/70	1	guard
11	0.065.1150.0/30	1	gasket
12	2.0432.003.7	2	stud bolt m 8 p.1.25 / p.1 x 20
13	2.0312.214.2	3	screw m 8 p.1.25 x 40
14	2.1480.014.1	15	washer 8
15	2.1470.004.2	4	lock washer 8
16	2.1011.405.2	2	nut m 8 p.1
17	2.1529.141.0	1	special oil seal
18	2.0312.208.2	8	screw m 8 p.1.25 x 25
19	2.0312.219.2	4	screw m 8 p.1.25x65

Section: ENGINE

CRANKSHAFT

9_33212_00_0_0

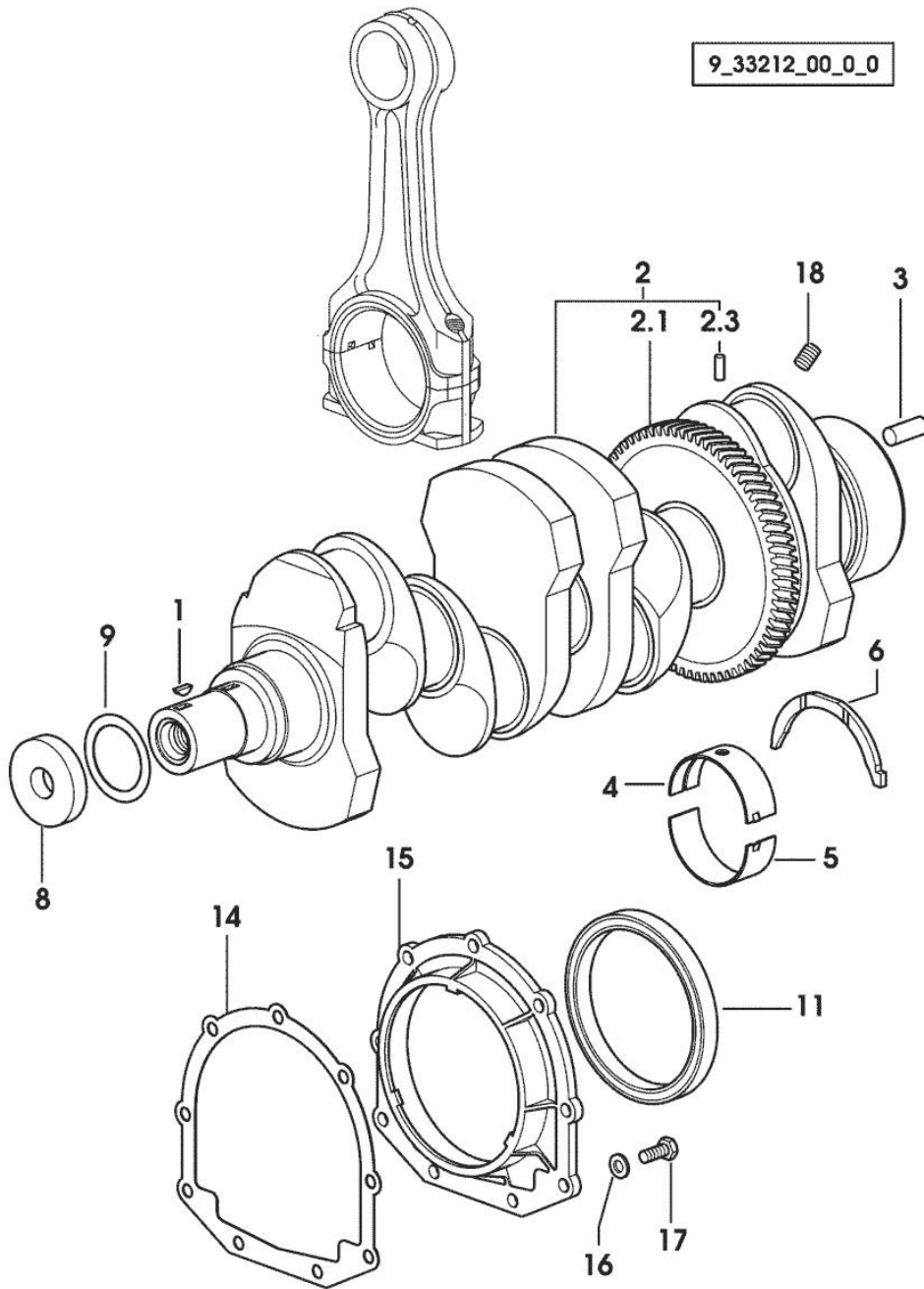

Fig.	P/n	QTY	Name
------	-----	-----	------

Notes:
[KRYPTON 80]

1	2.1720.006.0	1	key 4x6.5
2	0.086.1210.3/30	1	crankshaft
2.1	0.065.1211.0/10	1	crown wheel
2.3	2.1630.608.0	1	pin 6x16
3	2.1651.915.0	1	pin 12x35
4	0.065.1215.0	5	main half bushing STANDARD
4	0.065.1215.7		main half bushing - mm 0.25
4	0.065.1215.8		main half bushing - mm 0.50
5	0.065.1216.0	5	main half bushing
5	0.065.1216.7		main half bushing - mm 0.25
5	0.065.1216.8		main half bushing - mm 0.50
6	0.065.1218.0	4	shim STANDARD
6	0.065.1218.7		shim + mm 0.10
6	0.065.1218.8		shim + mm 0.15
8	2.1599.524.7	1	washer 21x60x12
9	2.1589.189.0	2	shoulder ring mm 1.00
11	2.1529.073.0	1	special oil seal 110x130x13
14	0.065.1254.0/20	1	gasket
15	0.007.1711.0/10	1	cover
16	2.1475.002.2	9	conical washer 8
17	2.0112.207.2	9	screw m 8 p 1.25 x 20
18	2.3130.001.1	4	plug 1/8" gas

CRANKSHAFT PULLEY

Fig.	P/n	QTY	Name
------	-----	-----	------

Notes:
[KRYPTON 80]

1	0.000.0000.1		cannot be supplied
1.1	0.008.2212.0/70	1	pulley
2	2.1589.136.0	2	shoulder ring 71x110x0.5
3	2.1589.137.0	2	shoulder ring 71x110x1
4	2.1470.006.2	6	lock washer 10
5	2.0112.323.2	6	screw m 10 p.1.5x70

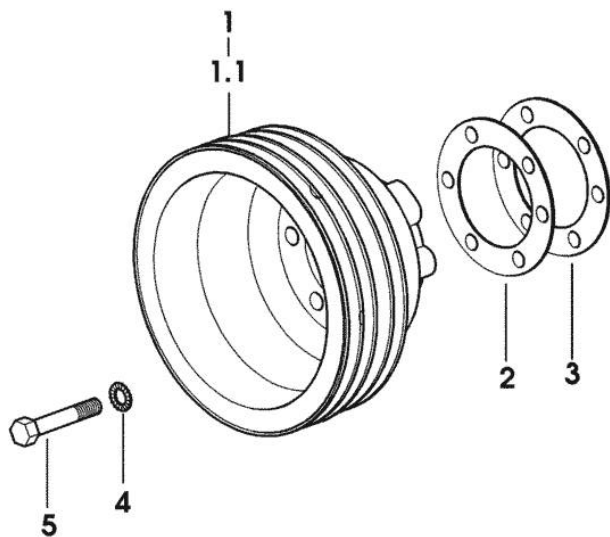

PULSE WHEEL

Fig.	P/n	QTY	Name
------	-----	-----	------

Notes:
[KRYPTON 80]

1	0.011.3512.0/10	1	hub
3	2.0399.144.7/10	1	screw m 20 p.1.5x51
4	2.1720.006.0	1	key 4x6.5

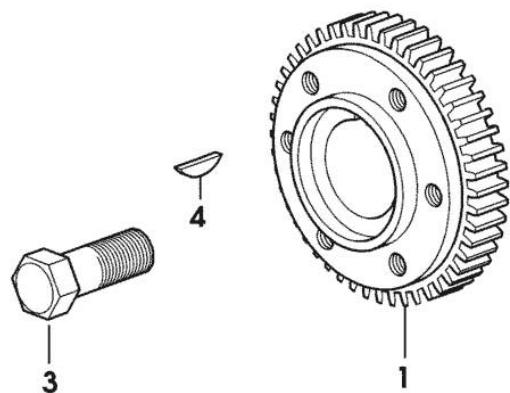

9_32112_01_0_0

CYLINDER - PISTON - CONNECTING ROD

Fig.	P/n	QTY	Name
------	-----	-----	------

Notes:
[KRYPTON 80]

1	0.007.0762.0/50	4	engine cylinder
2	0.379.0060.6/10	4	complete piston
2.1	0.086.0052.6/10	1	piston ring set
2.2	2.1411.014.1	2	circlip 35
2.3	0.078.1236.0	1	piston pin Ø 18 / Ø 35 / L = mm 86
3	0.078.1220.3/30	4	engine connecting rod
3.1	2.0399.213.0	2	screw m 12 p.1.25x61.5
3.2	2.1559.114.0/10	1	special bushing
4	0.065.1225.0	8	con.rod half bushing STANDARD - A = 28.75 -> 29.00
4	0.065.1225.7	8	con.rod half bushing - mm 0.25
4	0.065.1225.8	8	con.rod half bushing - mm 0.50

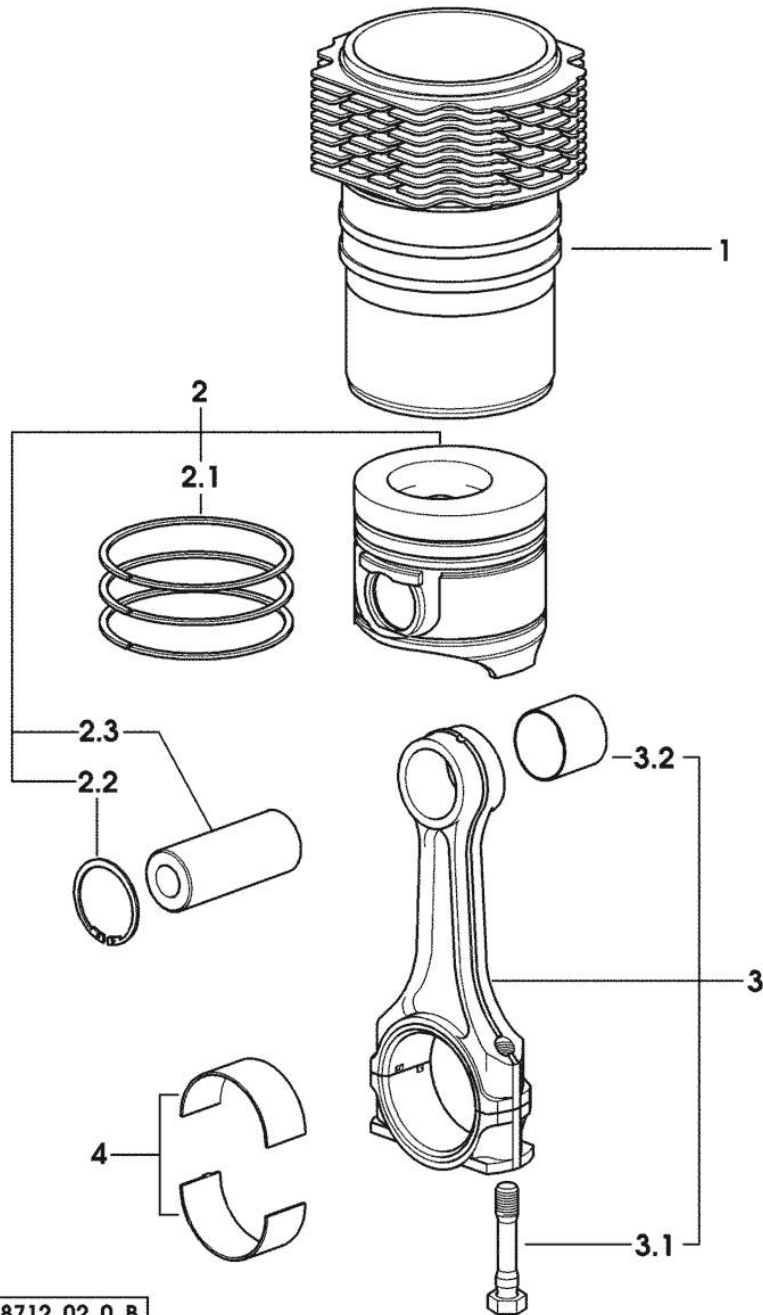

FLYWHEEL

Fig.	P/n	QTY	Name
------	-----	-----	------

Notes:
[KRYPTON 80]

55	0.066.1247.3/20	1	flywheel
55.2	0.065.1242.0	1	crown wheel Z = 123
56	0.255.2525.0/10	1	flange
57	2.0139.022.2	6	screw m 12 p.1.25x55
58	2.3199.135.2	1	plug

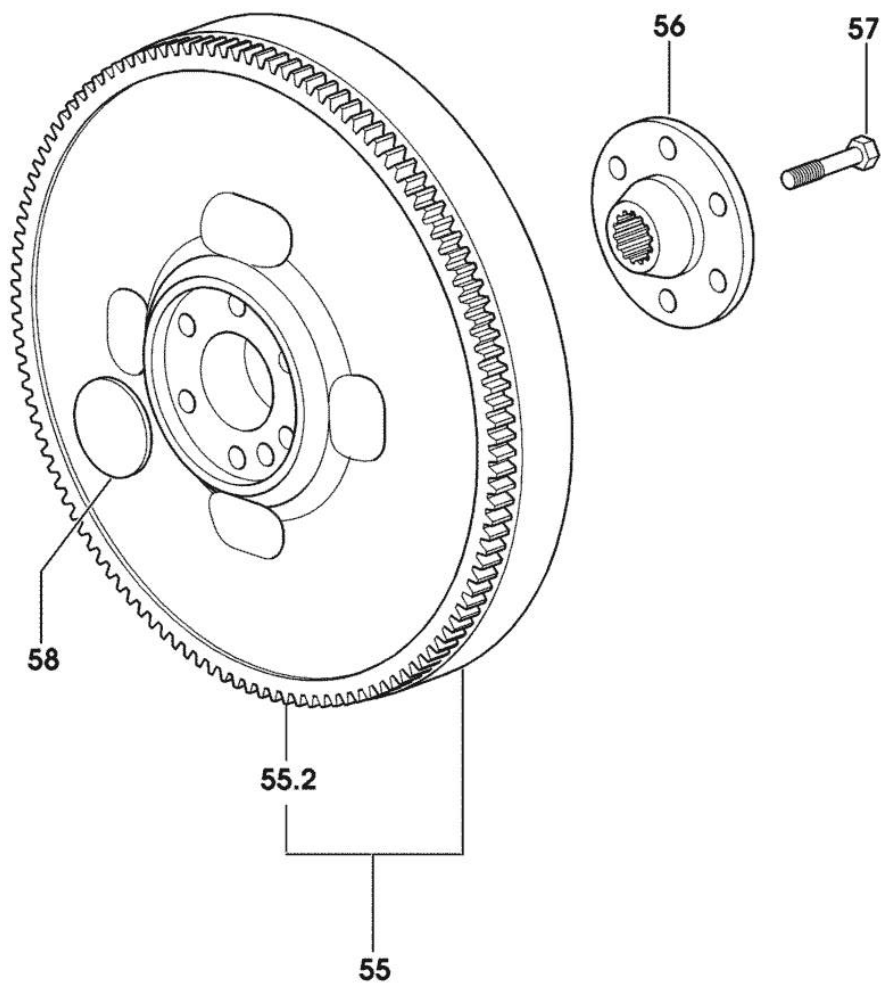

9_33212_06_0_0

Section: ENGINE

COUNTERWEIGHTS

Fig.	P/n	QTY	Name
------	-----	-----	------

Notes:
[KRYPTON 80]

25	2.1589.139.0	1	shoulder ring mm 0.3
26	2.1589.140.0	3	shoulder ring mm 0.1
29	2.1579.628.0	3	spacer 16.5x26x0.1
33	2.1579.629.0	6	spacer 12.5x26x0.1
34	2.1589.048.0	1	shoulder ring 16.5x26x0.3
35	2.1589.049.0	1	shoulder ring 12.5x26x0.3
40	0.086.1233.3/30	1	mass sx/lh/li
40.2	2.1559.115.0	2	special bushing 26x30x30
40.3	0.000.0000.1		cannot be supplied
40.4	2.1651.302.0	1	roll pin 4x6
41	0.065.1233.3/30	1	mass dx/rh/re
41.2	2.1559.115.0	2	special bushing 26x30x30
41.3	0.000.0000.1		cannot be supplied
41.99	0.000.0000.1		cannot be supplied
41.99.4	2.1651.302.0	1	roll pin 4x6
41.99.5	2.1410.018.7	1	circlip 45
42	0.000.0000.1		cannot be supplied
42.1	0.086.1231.0/10	1	box
42.2	2.3130.001.1	4	plug 1/8" gas
43	2.1631.717.0	2	roll pin 8 x 40
44	2.1579.626.0	2	spacer 13.2x16x11
45	2.0139.028.2	4	screw m 12
46	2.1699.191.0	1	bush 7x10x16
47	0.000.0000.1		cannot be supplied
47.1	0.065.1234.0/10	1	shaft
47.2	2.3130.001.1	1	plug 1/8" gas
48	2.1589.185.0	4	shoulder ring 26.1x34x1

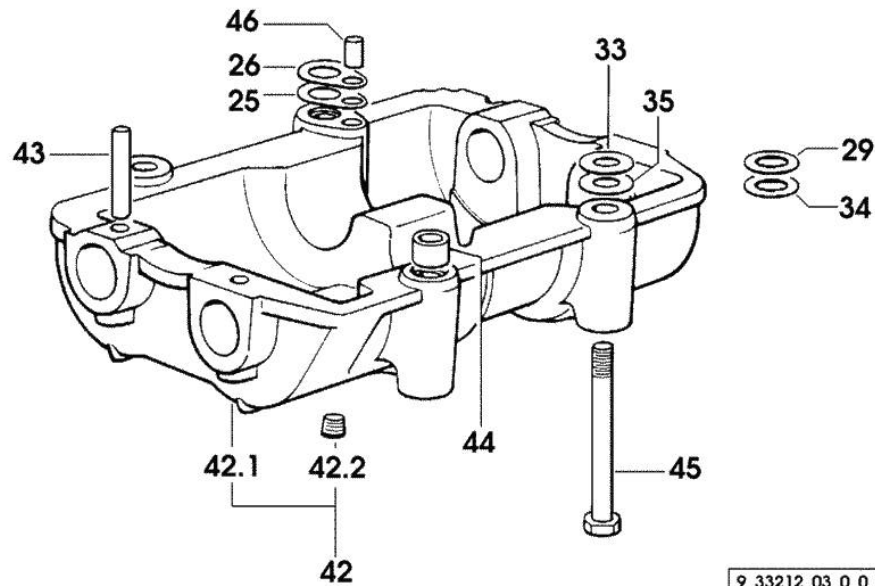
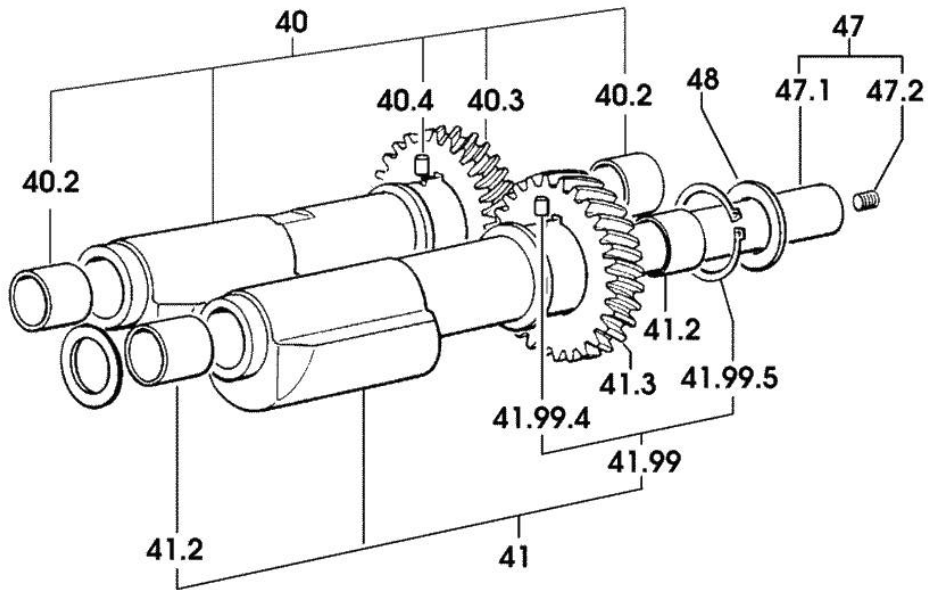

9_33212_03_0_0

Section: ENGINE

CAMSHAFT

Fig.	P/n	QTY	Name
------	-----	-----	------

Notes:
[KRYPTON 80]

1	0.065.1331.2	8	rod
2	2.1569.114.0/10	16	gasket 14x18.5x8
3	0.065.1332.0	8	sleeve
4	2.4019.300.1/10	8	spring 18.5x52x2
5	2.1599.437.0	8	shoulder ring
6	0.065.1330.0	8	tappets
7	0.065.1354.0/20	1	gear z=58
8	2.0132.207.2	4	screw m 10 p.1 x 25
9	0.066.1310.3/40	1	camshaft
9.2	0.065.1324.0/10	1	gear Z = 32
10	0.065.1350.0	1	small disc
11	2.1410.016.1	1	circlip 40
12	0.065.1352.0	1	shim
13	0.065.1351.0	2	shoulder ring
14	0.065.1323.0/30	1	gear Z = 29
16	2.0312.205.2	2	screw
17	2.1480.014.1	2	washer 8
18	0.065.1353.0	1	small plate
19	0.007.1177.3/10	1	gear z = 57
			- WITH RED IDENTIFICATION STAMP
19.2	2.1559.185.0/10	1	bushing
20	0.007.1178.3/10		gear z = 57
			- WITH YELLOW IDENTIFICATION STAMP
20.2	2.1559.185.0/10	1	bushing
21	0.007.1179.3/10		gear z = 57
			- WITH GREEN IDENTIFICATION STAMP
21.2	2.1559.185.0/10	1	bushing
22	2.1559.398.0	1	bushing 10.5x13x12

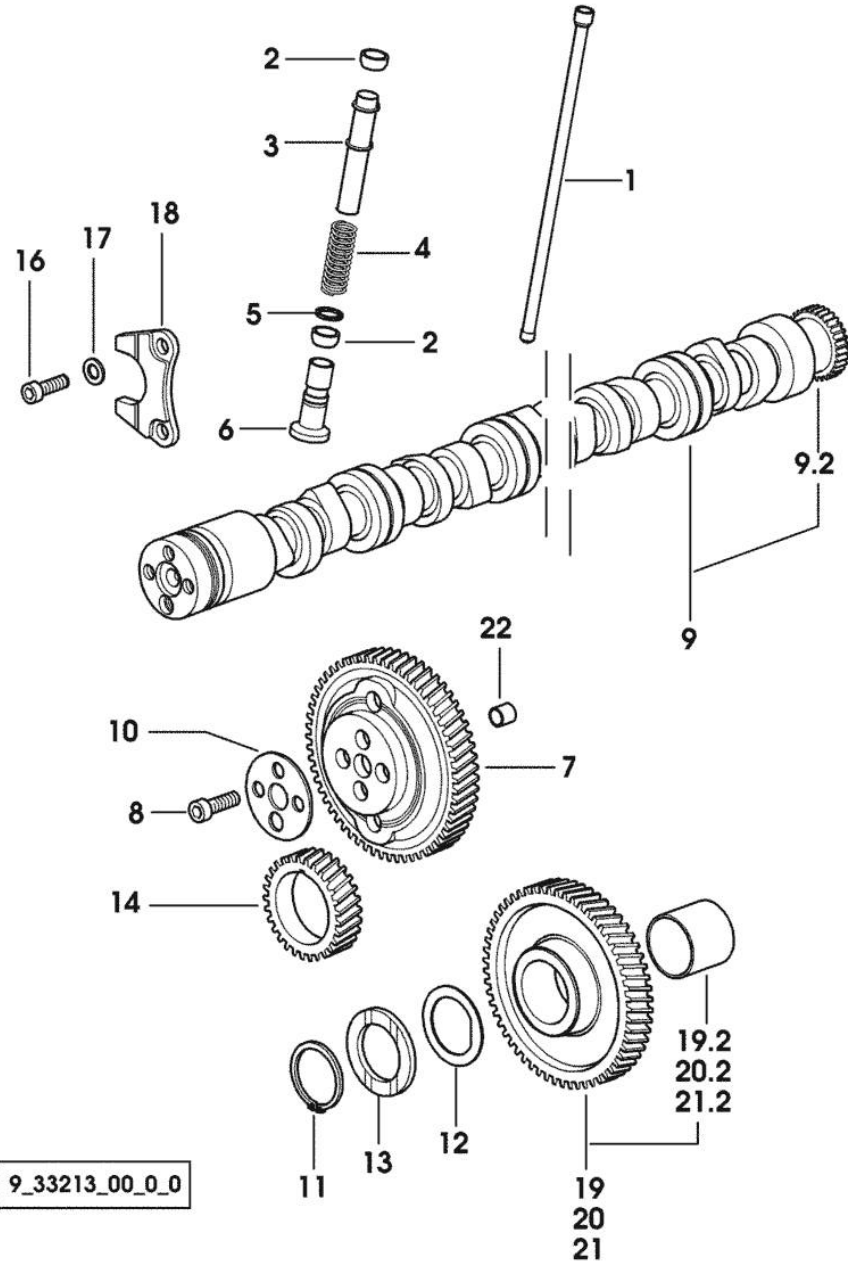

Section: ENGINE
CYLINDER HEAD

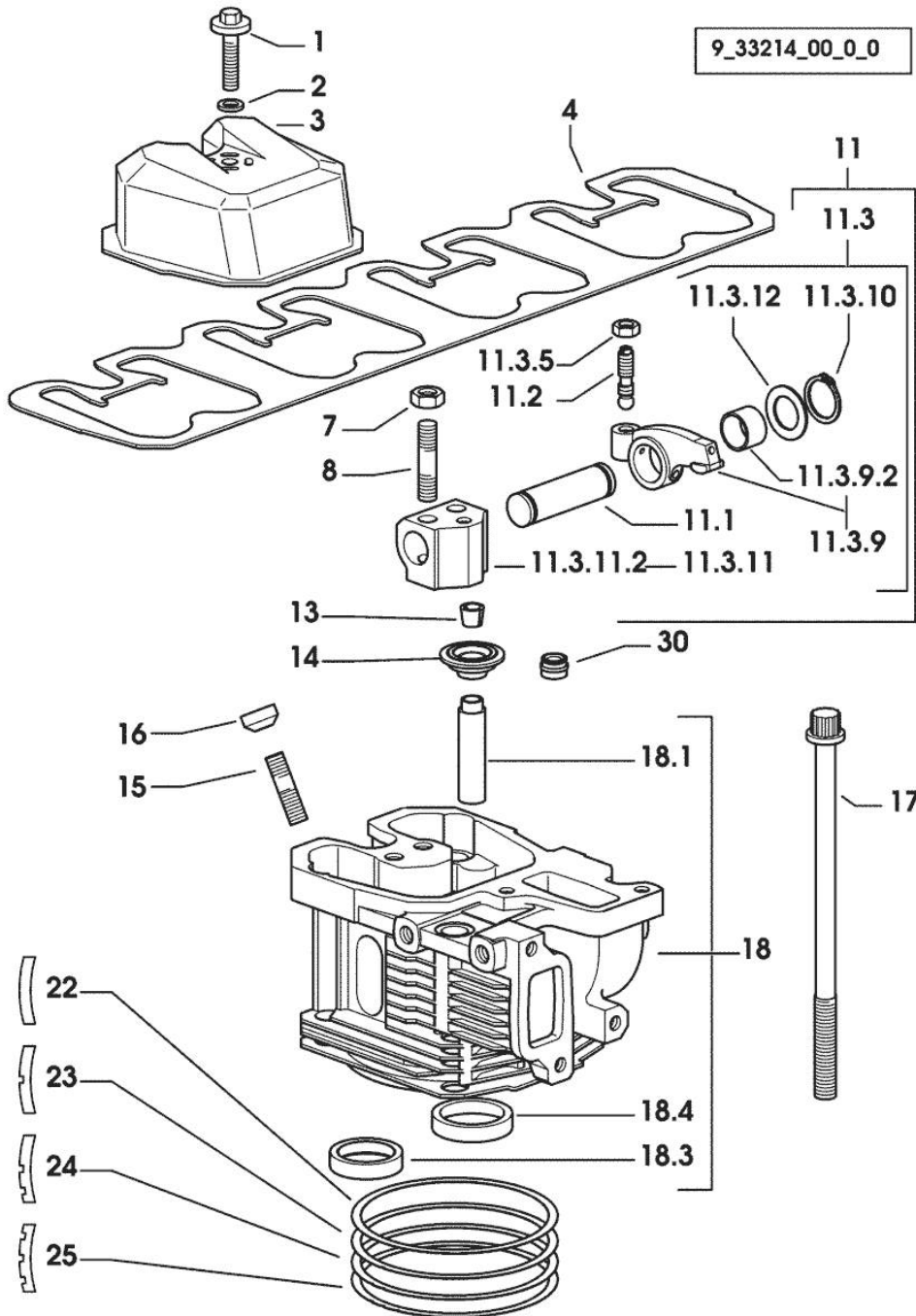

Fig.	P/n	QTY	Name
------	-----	-----	------

Notes:
[KRYPTON 80]

1	2.0399.288.2/10	4	screw m 8x36x46
2	2.1539.151.0	4	special oil seal 9.19 x 2.62
3	0.007.1139.0/10	4	small cap
4	0.065.1450.0/30	1	tappet gasket
7	2.1011.421.2	8	nut m 10 p.1.25
8	2.0432.163.7	8	stud bolt m 10 p.1.5 / p.1.25 x 45
11	0.000.0000.1		cannot be supplied
11.1	0.066.1431.0	1	pin
11.2	0.021.1434.0	2	screw
11.3	0.000.0000.1		cannot be supplied
11.3.5	2.1011.405.2	2	nut m 8 p.1
11.3.9	0.066.1432.3	2	rocker arm
11.3.9.2	2.1559.021.0/40	1	bushing 15x19x22
11.3.10	2.1410.055.7	2	circlip 19
11.3.11	0.000.0000.1		cannot be supplied
11.3.11.2	0.066.1430.0/10	1	support
11.3.12	2.1599.432.0	2	shoulder ring
13	0.074.1423.0	16	conical valve cotter
14	0.066.1425.0	8	cup
15	2.0432.161.7	4	stud bolt m 10 p.1.5 / p.1.25 x 40
16	0.007.1122.0/10	4	bush L = mm 6.4
17	0.065.1443.0/20	16	screw
18	0.007.1110.3/50	4	engine head
18.1	0.007.1779.0/10	2	valve guide
18.3	0.066.1427.0	1	valve seat
18.4	0.078.1426.0	1	valve seat
22	0.085.1450.0		head gasket mm 0.5 -A-
23	0.085.1451.0	3	head gasket mm 0.7 -B-
24	0.085.1452.0	1	head gasket mm 1.0 -C-
25	0.085.1453.0	3	head gasket mm 0.8 -D-
30	2.1519.117.0	8	special oil seal



Suggest:

For more complete manuals. Please go to the home page.

<https://www.ebooklibonline.com>

If the above button click is invalid. Please download this document first, and then click the above link to download the complete manual.

Thank you so much for reading

INLET AND EXHAUST VALVES

Fig.	P/n	QTY	Name
------	-----	-----	------

Notes:
[KRYPTON 80]

30	0.066.1421.0	4	exhaust valve
31	0.010.6016.0	4	inlet valve mm 43.63 / Ø mm 9

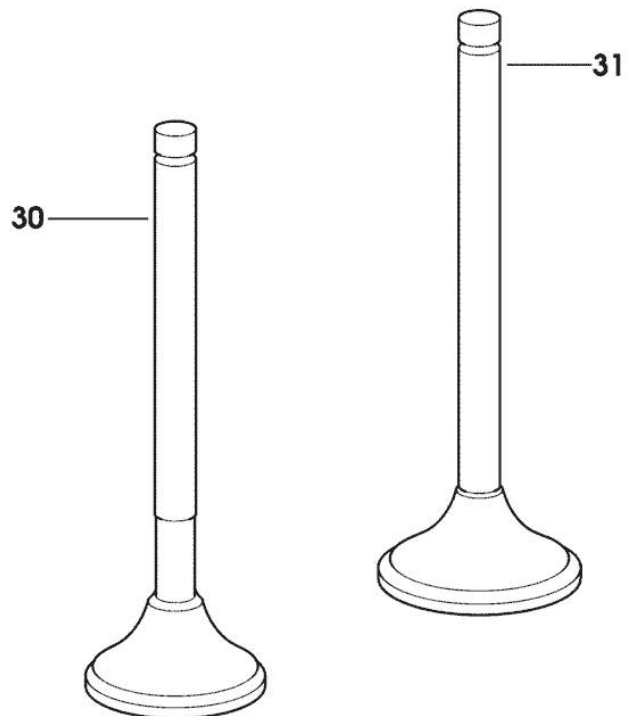

9_33214_03_0_0

INLET AND EXHAUST VALVE SPRINGS

Fig.	P/n	QTY	Name
------	-----	-----	------

Notes:
[KRYPTON 80]

25	2.4019.287.0	8	spring
----	--------------	---	--------

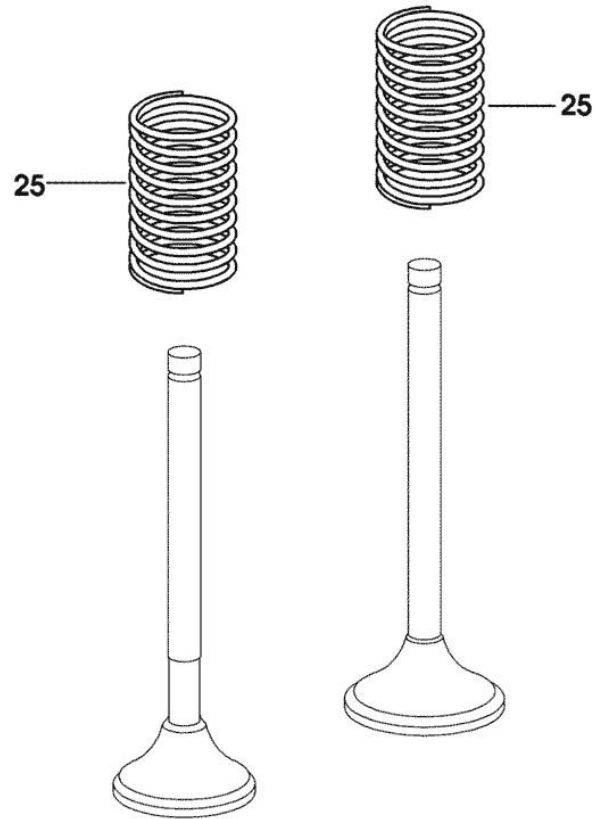

9_33214_01_0_0

<https://www.ebooklibonline.com>

Hello dear friend!

Thank you very much for reading.

Enter the link into your browser.

The full manual is available for immediate download.

<https://www.ebooklibonline.com>