

**SERVICE BRAKES 2093 009 101**

Fig.	P/n	QTY	Name
10	0.900.0800.4	2	transmission brake
10.10	0.900.0801.0	2	rod
			(...) <-
10.10	04428551	1	rod
			-> (...)
10.20	04435740	1	pin
10.30	0.900.0801.1	2	split pin
			(...) <-
10.30	04435741	1	split pin
			-> (...)
30	0.900.0800.5	2	operation
50	0.900.0469.7	6	screw m 10 x 40
60	04434557	4	nut m 14 p.1.5
70	04428545	1	tube sx/lh/li
80	04428546	1	pipng dx/rh/re
88	0.900.0468.2	2	clamp 6x12
100	0.900.0280.1	2	screw m 5 x 25
110	0.900.0470.2	2	nut m 5
120	0.900.0281.6	2	nut
200	0.900.0800.9	2	rubber bushing
210	0.900.0801.2	10	disc
220	0.900.0801.3	8	disc

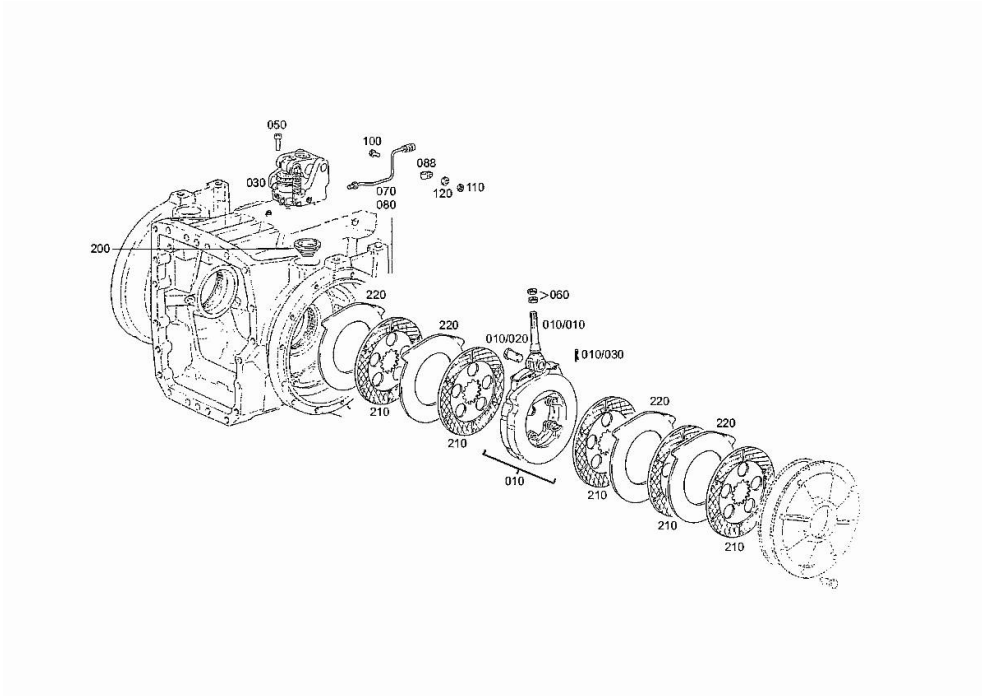

**BRAKE CONTROLS 2093 009 101**

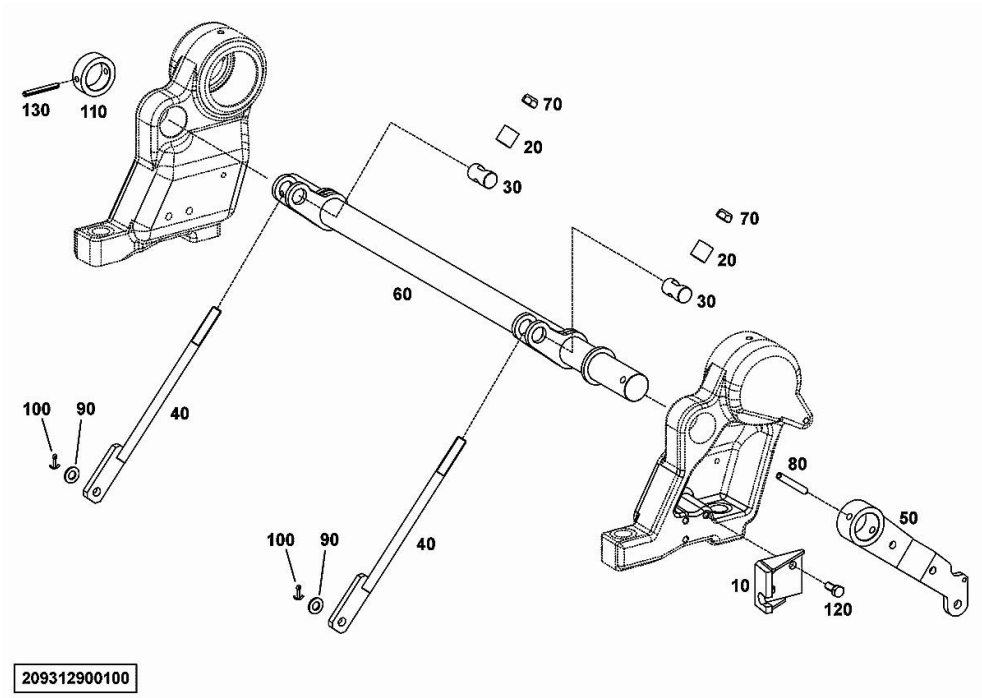
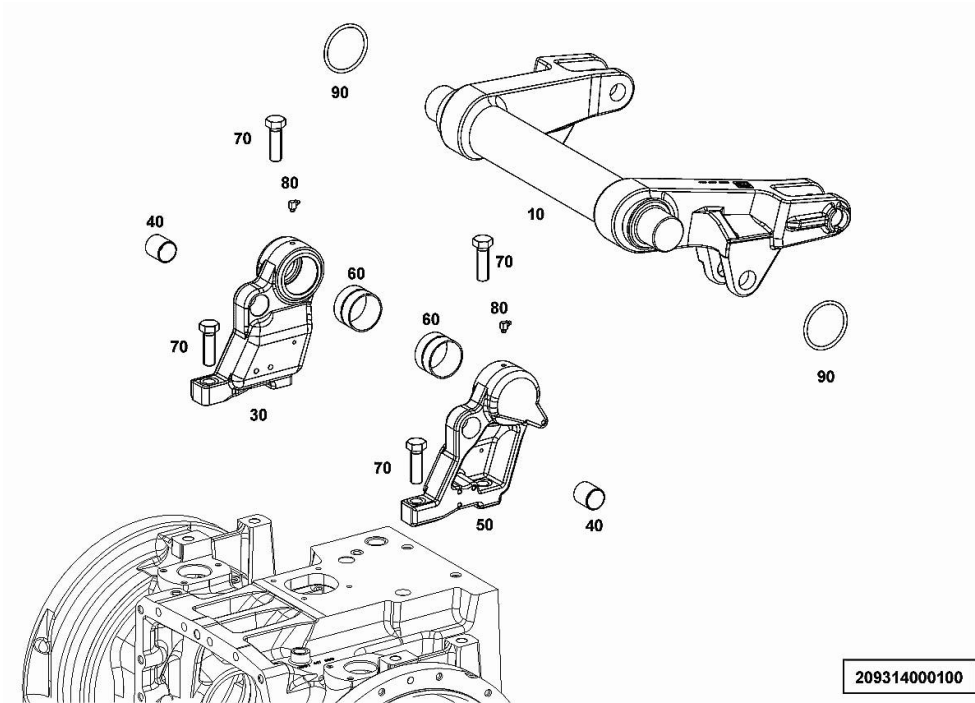

Fig.	P/n	QTY	Name
10	0.010.2901.2	1	support (...) <-
10	0.900.1239.7	1	bracket > (...)
20	0.010.2902.0	2	bushing (...) <-
20	0.900.1239.8	2	tube > (...)
30	0.010.2902.1	2	pin > (...)
30	0.900.1239.9	2	pin (...) <-
40	0.010.2902.2	2	connecting rod > (...)
40	0.900.1240.0	2	rod (...) <-
50	0.900.0466.8	1	brake lever (...) <-
50	0.900.1240.1	1	lever > (...)
60	0.010.2903.1	1	shaft (...) <-
60	0.900.1240.2	1	shaft > (...)
70	0.900.0281.9	2	nut m 12
80	0.010.3459.1	1	roll pin
90	0.900.0466.9	2	washer
100	0.900.0468.1	2	split pin 3.2x18
110	0.010.2904.2	1	ring (...) <-
110	0.900.1240.3	1	spacer > (...)
120	0.900.0469.4	3	screw m 8 p.1.25 x 20
130	0.010.2901.1	1	pin 6x50

**LIFTING 2093 009 101**

Fig.	P/n	QTY	Name
10	0.900.0883.4	1	shaft
30	0.900.0802.9	1	bearing block dx/rh/re
40	0.010.3844.1	2	bearing
50	0.900.0803.0	1	bearing block sx/lh/li
60	04417549	2	special bushing
70	0.900.0469.1	4	screw m 20x65
80	04427636	2	grease gun m 8 p.1 x 8
90	04417552	2	ring 78.5x6



**<https://www.ebooklibonline.com>**

Hello dear friend!

Thank you very much for reading.

Enter the link into your browser.

The full manual is available for immediate download.

**<https://www.ebooklibonline.com>**

**GEAR SHIFTING 2093 009 101**

Fig.	P/n	QTY	Name
10	0.900.0952.1	1	control
10.10	0.900.0952.8	1	solenoid valve DV
20	04434512	2	plug m 10 p.1 FINO A MATRICOLA CAMBIO ZF 01853553
30	0.900.0290.7	2	circlip FINO A MATRICOLA CAMBIO ZF 01853553
40	0.900.0801.4	4	ring 11,3 x 2,4 NBR-70-10
50	0.010.2628.2	1	control FINO A MATRICOLA CAMBIO ZF 01853553
50	0.900.1363.3	1	small block DA MATRICOLA CAMBIO ZF 1853554
50.10	0.900.1384.6	1	solenoid valve DA MATRICOLA CAMBIO ZF 1853554
60	0.900.0279.5	2	screw FINO A MATRICOLA CAMBIO ZF 01853553
60	0.900.1363.4	2	screw DA MATRICOLA CAMBIO ZF 1853554
70	0.900.0281.0	1	plug m 14 p.1.5 FINO A MATRICOLA CAMBIO ZF 01853553
80	04423731	1	oil seal 14 x 18 FINO A MATRICOLA CAMBIO ZF 01853553

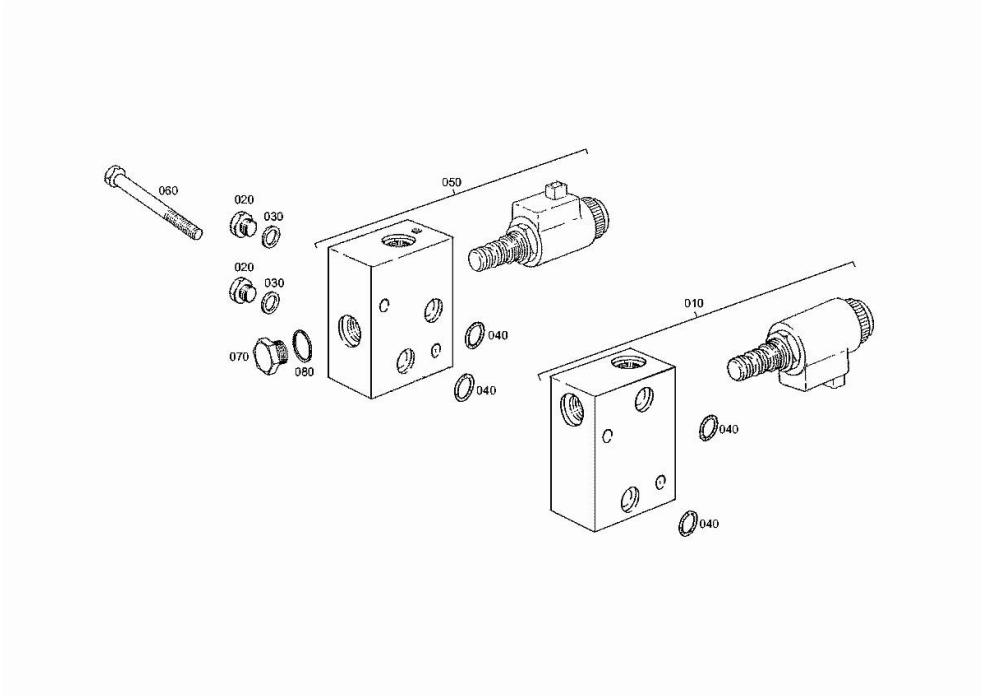

**FLEXIBLE COUPLINGS**

Fig.	P/n	QTY	Name
------	-----	-----	------

**Notes:**

[IRON 175 DCR HI-LINE -> 20001]

1	04438731.4	1	vibration damper
2	2.1475.003.2	6	washer 10
3	2.0113.320.7	6	screw m 10 p.1.5 x 55

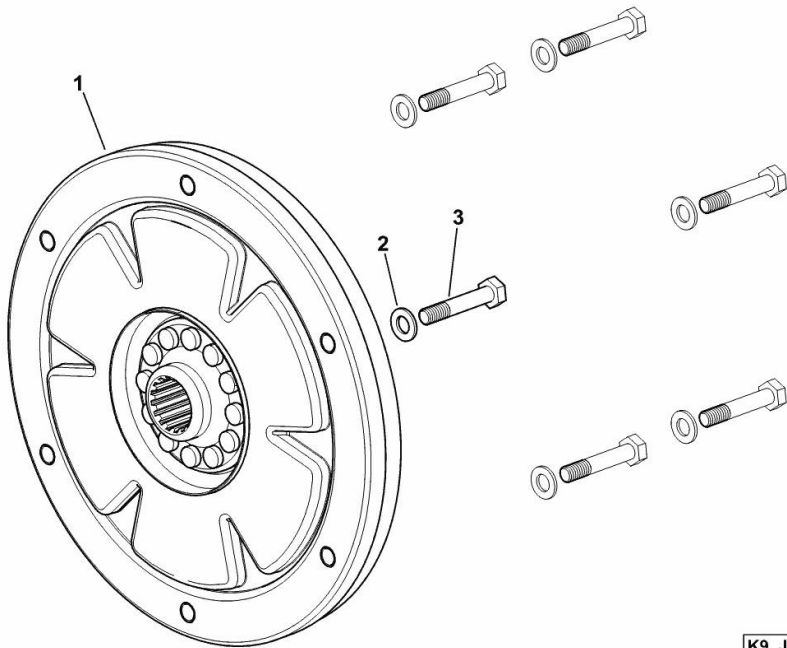

K9\_J6630\_02\_0-A-001

**FIXING PARTS - MOTOR - GEARS**

Fig.	P/n	QTY	Name
------	-----	-----	------

**Notes:**

[IRON 175 DCR HI-LINE -> 20001]

1	04455205/10	1	flange
2	2.0113.629.2	2	screw m 16 p.2x100
3	2.1475.106.7	8	washer 17x32
4	2.0439.281.7/10	2	stud bolt m 12 p.1.75-1.25x238
5	2.0439.282.7/10	2	stud bolt m 16 p.2-1.5x252
6	2.0439.296.7/10	2	stud bolt m 16 p.2-1.5x242
7	2.0439.283.7/10	2	stud bolt m 16 p.2-1.5x297
8	2.1012.409.7	6	nut m 16
9	2.1011.422.2	2	nut m 12 p.1.25
10	2.1475.104.7	2	washer 13 x 24

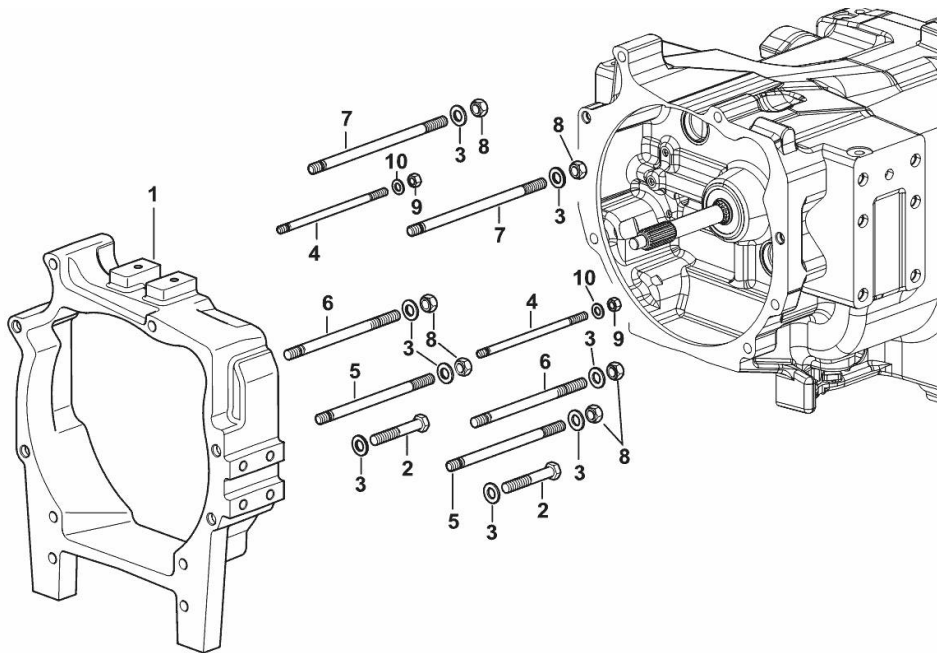

K9\_J6631\_03\_0-A-001

**SEPARATOR mm 35**

Fig.	P/n	QTY	Name
------	-----	-----	------

**Notes:**

- FOR MODELS WITHOUT FRONT LIFT [IRON 175 DCR HI-LINE -> 20001]

1	0.015.7283.0	1	spacer mm 35
---	--------------	---	--------------

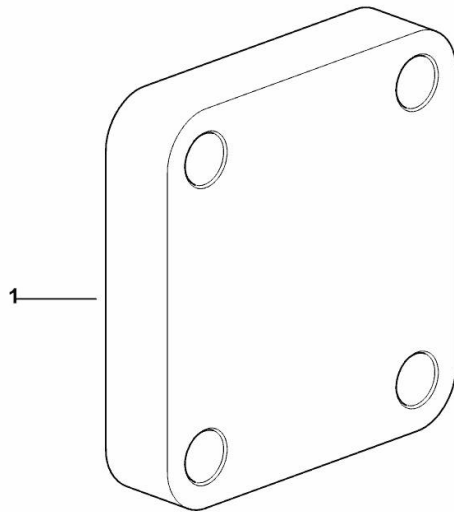

K9\_J6356\_01\_0-A-001

**SEPARATOR mm 15**

Fig.	P/n	QTY	Name
------	-----	-----	------

**Notes:**

- FOR MODELS WITH FRONT LIFT [IRON 175 DCR HI-LINE -> 20001]

1	0.015.7285.2	1	spacer mm 15
---	--------------	---	--------------

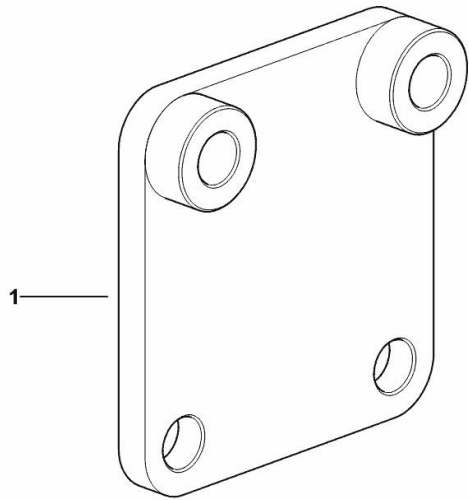

K9\_J6356\_02\_0-A-001

**GEAR SHIFTING**

Fig.	P/n	QTY	Name
------	-----	-----	------

**Notes:**

[IRON 175 DCR HI-LINE -> 20001] 20002 <-

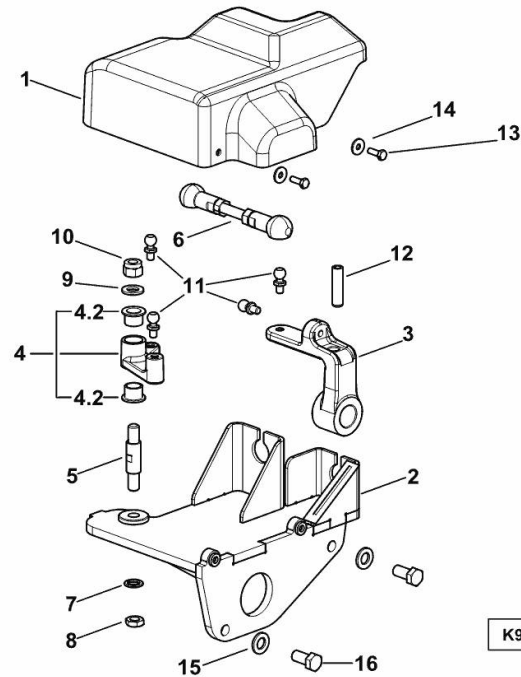

K9\_J3164\_04\_0-A-001

1	0.016.3928.0/10	1	cover
2	0.016.5459.2/20	1	support
3	0.016.3972.0/20	1	lever
4	0.016.3962.4	1	lever
4.2	2.1559.276.0/10	2	special bushing 16x20x15
5	0.016.2711.0/10	1	pin
6	0.016.3969.4/10	1	rod
7	2.1474.011.2	1	spring washer 12
8	2.1011.107.2	1	nut m 12 p.1.75
9	2.1310.007.2	1	flat washer 13 x 24
10	2.1120.007.2	1	self-locking nut m 12 p.1.75
11	0.014.1947.0	4	small pin
12	2.1630.916.2	1	pin 12x45
13	2.0112.006.2	2	screw m 6 p.1 x 18
14	2.1312.003.2	2	washer 6
15	2.1475.104.6	2	screw 13 x 24
16	2.0114.409.2	2	screw m 12 x 25

**GEAR SHIFTING**

Fig.	P/n	QTY	Name
------	-----	-----	------

**Notes:**

[IRON 175 DCR HI-LINE -> 20001]

1	0.019.4943.0	1	cover
2	0.016.5459.2/20	1	support
3	0.019.5033.0	1	lever
4	0.019.5053.4	1	lever
4.2	2.2725.020.0	2	roller cage 16x22x16
4.3	2.1519.078.0	2	special oil seal 16 x 24 x 6
5	0.016.2711.0/20	1	pin
6	0.019.4543.4	1	stay
7	2.1474.011.2	1	spring washer 12
8	2.1011.107.2	1	nut m 12 p.1.75
9	2.1312.005.2	1	washer 10.2
10	2.1120.006.2	1	nut m 10 p.1.5
11	2.0312.208.2	2	screw m 8 p.1.25 x 25
12	2.1630.916.2	1	pin 12x45
13	2.0112.006.2	2	screw m 6 p.1 x 18
14	2.1312.003.2	2	washer 6
15	2.1475.104.6	2	screw 13 x 24
16	2.0114.409.2	2	screw m 12 x 25
17	2.0312.214.2	1	screw m 8 p.1.25 x 40
18	2.1549.780.2	4	washer

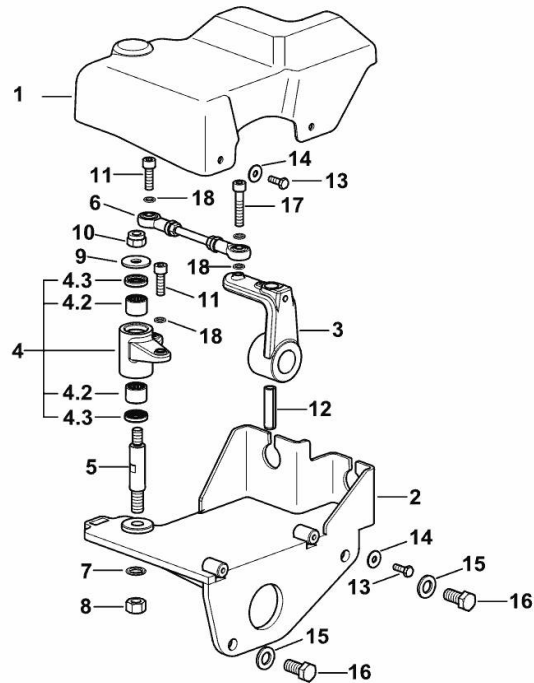

K9\_J3164\_04\_0-A-002

**SUPER-REDUCTION CONTROL**

Fig.	P/n	QTY	Name
------	-----	-----	------

**Notes:**

[IRON 175 DCR HI-LINE -> 20001]

3	04415458.4	1	lever
3.1	04414553.4	1	lever
3.2	04414554.4	1	tube
3.3	04414549	1	spring
3.4	04414557	2	pin
3.5	01175655	2	stop
4	2.1630.916.2	1	pin 12x45

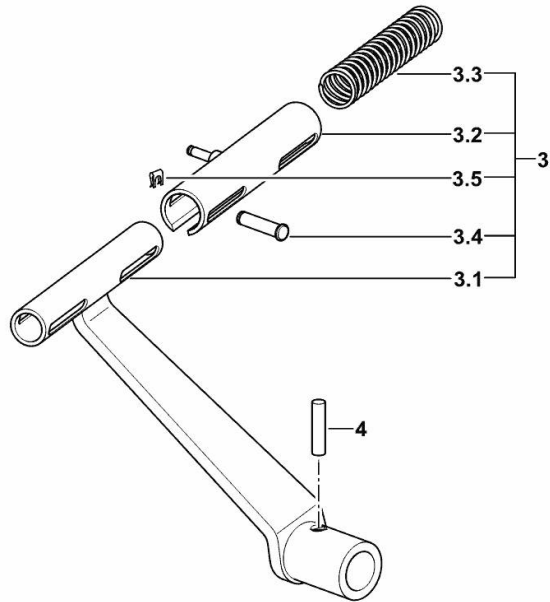

K9\_D4064\_03\_0-A-003

**SUPER-REDUCTION CONTROL**

Fig.	P/n	QTY	Name
------	-----	-----	------

**Notes:**

[IRON 175 DCR HI-LINE -> 20001]

3	0.017.9592.4/10	1	lever
3.2	04414554.4	1	tube
3.3	04414549	1	spring
3.4	04414557	2	pin
3.5	01175655	2	stop
4	2.1630.916.2	1	pin 12x45
8	01175725	1	clip 6, d128

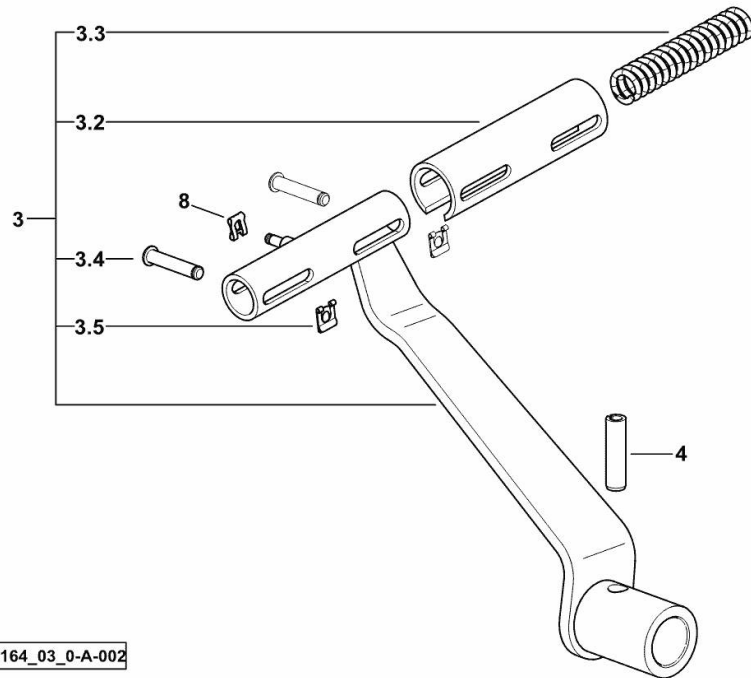

K9\_R5164\_03\_0-A-002

**LINKAGE**

Fig.	P/n	QTY	Name
1	0.016.3969.4/10	1	rod
2	0.900.1389.8	1	rod
3	0.900.1389.9	2	nut
4	0.900.1390.0	2	tip

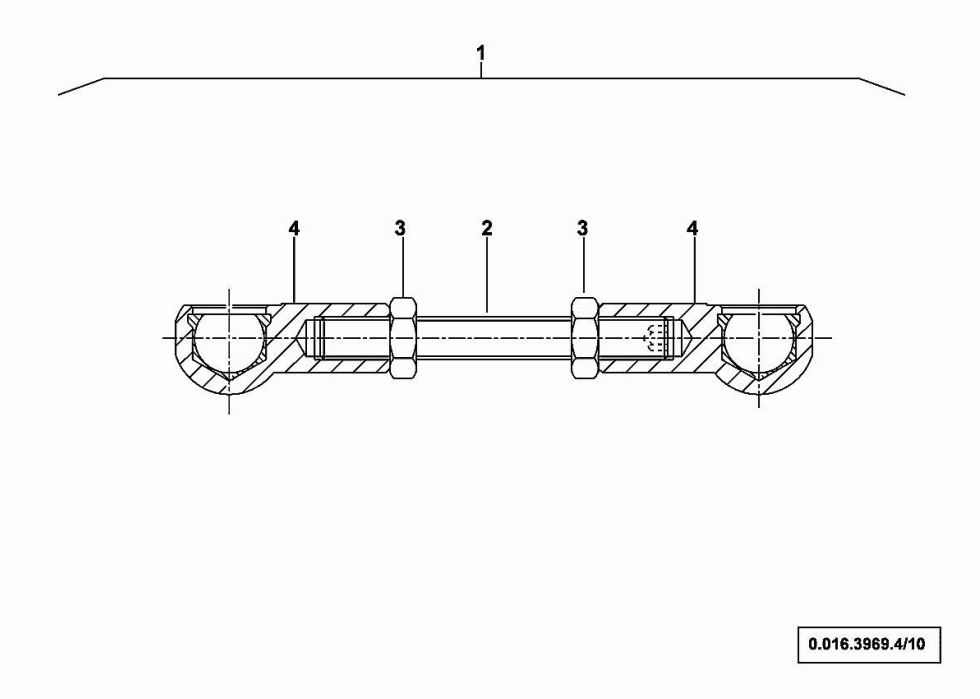



**Suggest:**

**For more complete manuals. Please go to the home page.**

**<https://www.ebooklibonline.com>**

**If the above button click is invalid. Please download this document first, and then click the above link to download the complete manual.**

**Thank you so much for reading**

**PTO OUTPUT SHAFT Z = 21**

Fig.	P/n	QTY	Name
------	-----	-----	------

**Notes:**

[IRON 175 DCR HI-LINE -> 20001]

1	04413621	1	shaft Z = 21
---	----------	---	--------------

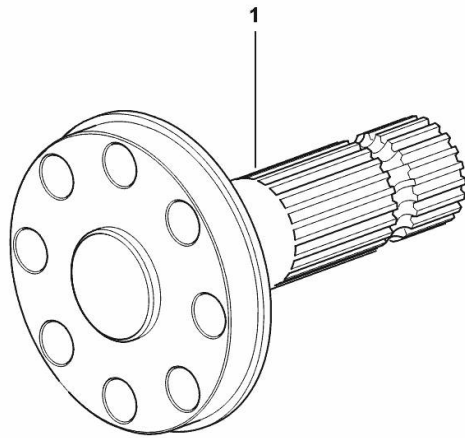

K9\_B1636\_11\_0-A-001

**PTO OUTPUT SHAFT 1"3/4, Z = 20**

Fig.	P/n	QTY	Name
------	-----	-----	------

**Notes:**

[IRON 175 DCR HI-LINE -> 20001]

1	04413632	1	shaft 1"3/4, Z = 20
---	----------	---	---------------------

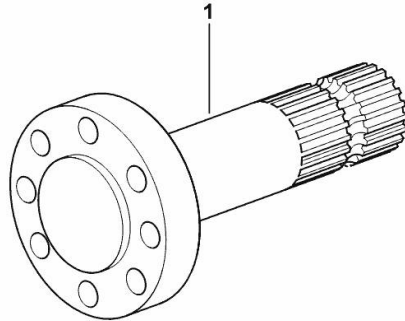

K9\_F5336\_11\_0-A-001

**<https://www.ebooklibonline.com>**

Hello dear friend!

Thank you very much for reading.

Enter the link into your browser.

The full manual is available for immediate download.

**<https://www.ebooklibonline.com>**