

INTERCOOLER

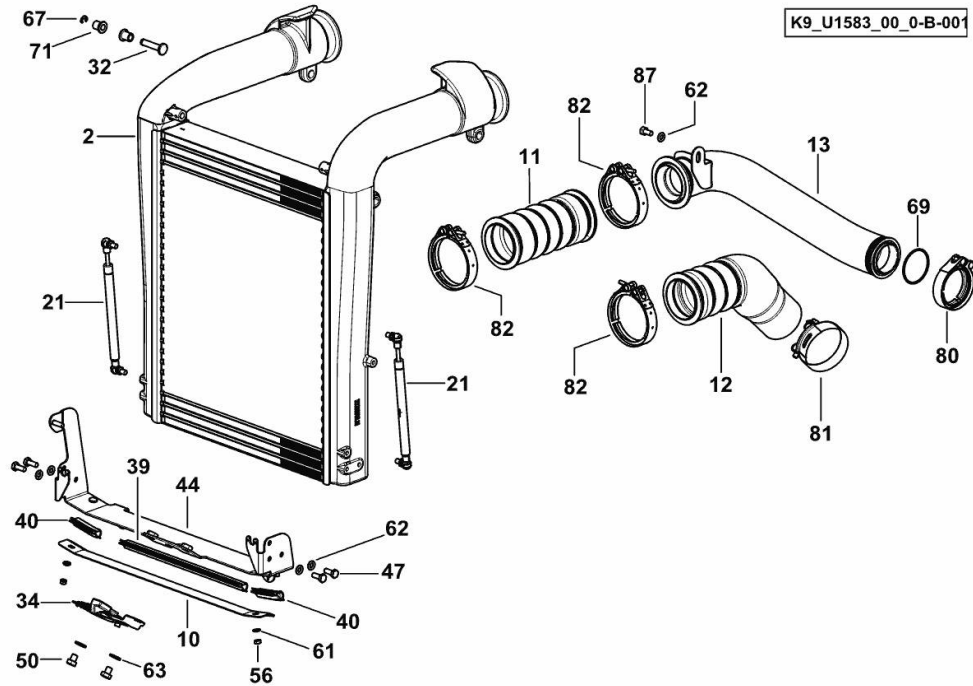

Fig.	P/n	QTY	Name
------	-----	-----	------

Notes:

[Fortis 190 ->WSXU360200LS50010]

2	0.021.2353.4	1	intercooler
10	0.019.0632.0/10	1	bracket
11	0.019.0603.4	1	sleeve
12	0.019.0594.4	1	sleeve
13	0.019.0617.2/10	1	tube
21	0.018.8024.4	2	shock absorber
32	0.017.4798.0	2	pin
34	0.013.3609.4	1	lock
39	0.019.0633.0	1	gasket
40	0.019.0634.0	2	gasket
44	0.019.0098.3/20	1	support
47	2.0112.207.2	4	screw m 8 p 1.25 x 20
50	2.0112.303.2	2	screw m 10 p.1.5x12
56	2.1011.103.2	4	nut m 6 p.1
61	2.1310.002.2	7	flat washer 6.4x12.5
62	2.1310.004.2	13	flat washer 8.4x17
63	2.1310.006.2	6	flat washer 10.5x21
67	2.1430.009.2	2	ring 8
69	2.1532.143.0	1	oil seal
71	2.1559.147.0	4	bushing
80	2.6859.118.0	1	clamp Ø 77
81	2.6859.148.2	1	clamp Ø 79-85
82	2.6859.166.0	3	clamp Ø 97
87	2.0112.205.2	1	screw m 8 p.1.25 x 16

AIR INTAKE TUBE

Fig.	P/n	QTY	Name
------	-----	-----	------

Notes:

[Fortis 190 ->WSXU360200LS50010]

1	0.018.3658.0/20	1	sleeve
2	0.018.1794.0	1	shield
3	0.015.7527.0	1	tube
4	04431291.4	1	tube
4.1.3	04434787	1	plate
4.1.4	04434788	1	plate
4.1.5	04423627	13	stop
5	0.017.8380.3	1	small plate
6	0.017.8369.0/20	1	bracket
7	04453928	1	support
9	2.1312.004.2	4	washer 8x24x2
10	2.0112.205.2	4	screw m 8 p.1.25 x 16
11	2.1312.002.2	2	washer 5
12	2.1851.005.0	2	rivet 4.8
13	2.1310.002.2	2	flat washer 6.4x12.5
14	2.1011.103.2	2	nut m 6 p.1
15	2.1310.004.2	4	flat washer 8.4x17
16	2.1011.105.2	4	nut m 8 p.1.25
17	2.6851.013.0	2	clamp 120-140

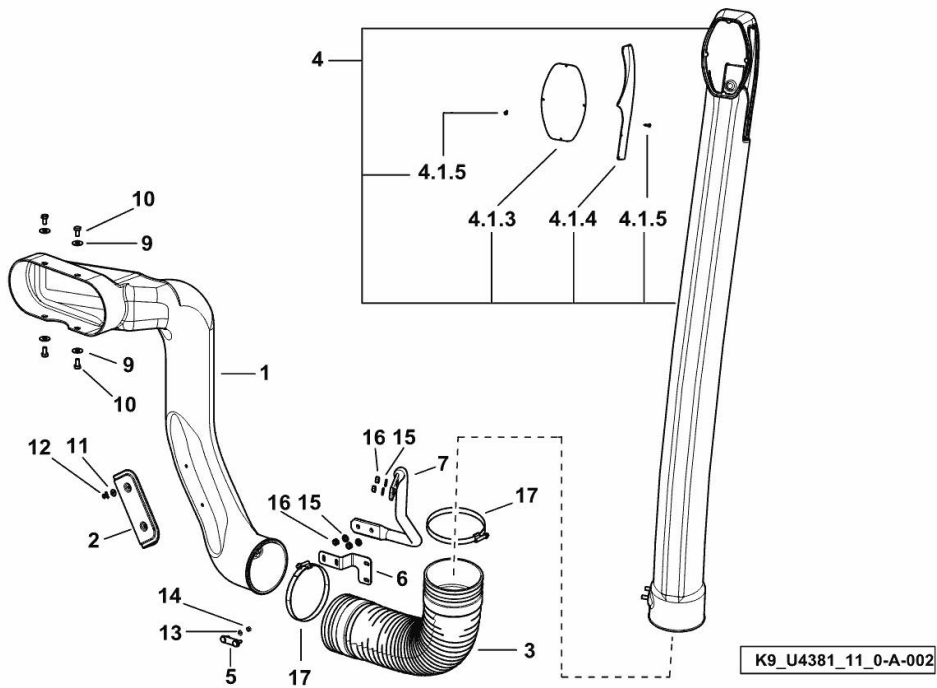

ENGINE AIR INTAKE PIPE BRACKET

Fig.	P/n	QTY	Name
------	-----	-----	------

Notes:

[Fortis 190 ->WSXU360200LS50010]

1	04413465	1	bracket
2	2.1310.004.2	2	flat washer 8.4x17
3	2.1011.105.2	1	nut m 8 p.1.25
4	01174042	1	cap
5	2.0114.207.2	1	screw m 8 p.1.25 x 20

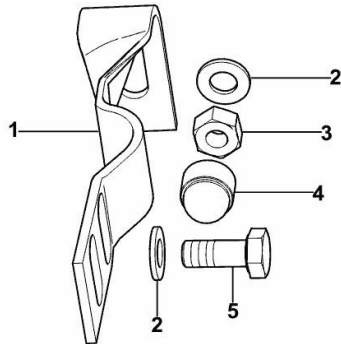

K9_U1581_12_0-A-001

<https://www.ebooklibonline.com>

Hello dear friend!

Thank you very much for reading.

Enter the link into your browser.

The full manual is available for immediate download.

<https://www.ebooklibonline.com>

AIR CLEANER

Fig.	P/n	QTY	Name
------	-----	-----	------

Notes:

[Fortis 190 ->WSXU360200LS50010]

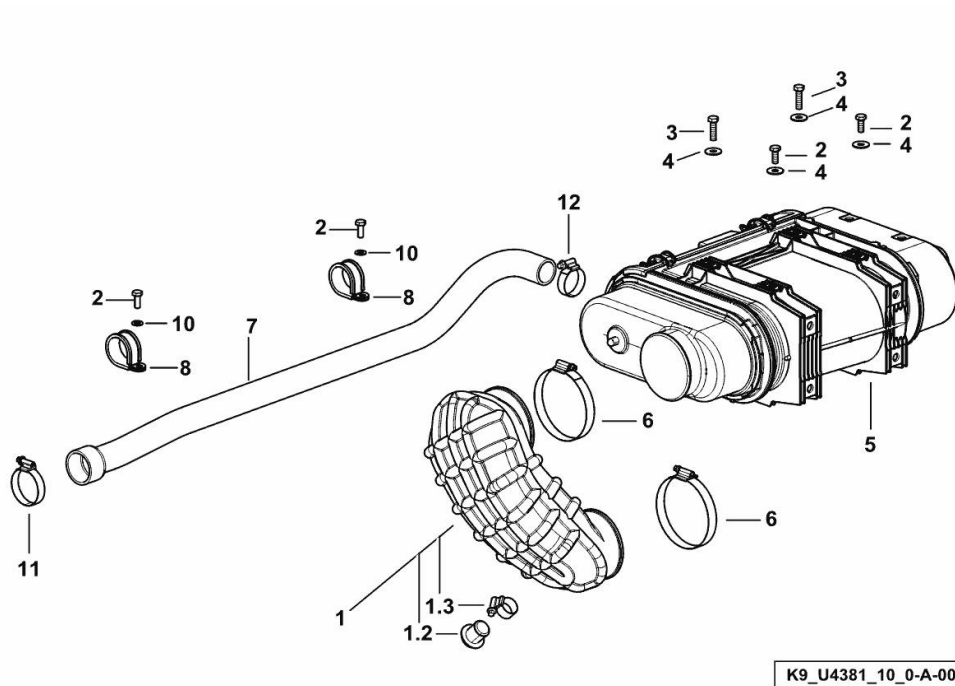

1	0.018.8198.4	1	sleeve
1.2	0.016.2956.0	1	plug
1.3	2.6851.002.0	1	clamp Ø 20/32
2	2.0112.207.2	4	screw m 8 p 1.25 x 20
3	2.0112.211.2	2	screw m 8 p.1.25 x 30
4	2.1312.004.2	4	washer 8x24x2
5	2.4249.734.0/10	1	air filter (50010 <-)
	☞ 2.4249.734.0/10		
5	2.4249.734.0/20	1	air filter
	☞ 2.4249.734.0/20		
6	2.6859.150.0	2	clamp 95/118
7	0.018.6601.0	1	tube
8	2.6839.069.0	2	clamp 40/20
10	2.1310.004.2	2	flat washer 8.4x17
11	2.6851.005.0	1	clamp Ø 40/60
12	2.6851.004.0	1	clamp Ø 32/50

K9_U4381_10_0-A-002

AIR FILTER 9"

Fig.	P/n	QTY	Name
1	2.4249.734.0/10	1	air filter
2	0.900.0272.1	1	internal air filter element
3	0.900.1633.4	1	filter
4	0.000.0000.1		cannot be supplied
5	0.000.0000.1	1	cannot be supplied
6	0.900.1383.8	1	guard
7	0.900.1633.5	1	cover
8	0.900.1633.6	1	exhaust valve
9	0.900.2064.4	1	accessories U-CLIP BAG

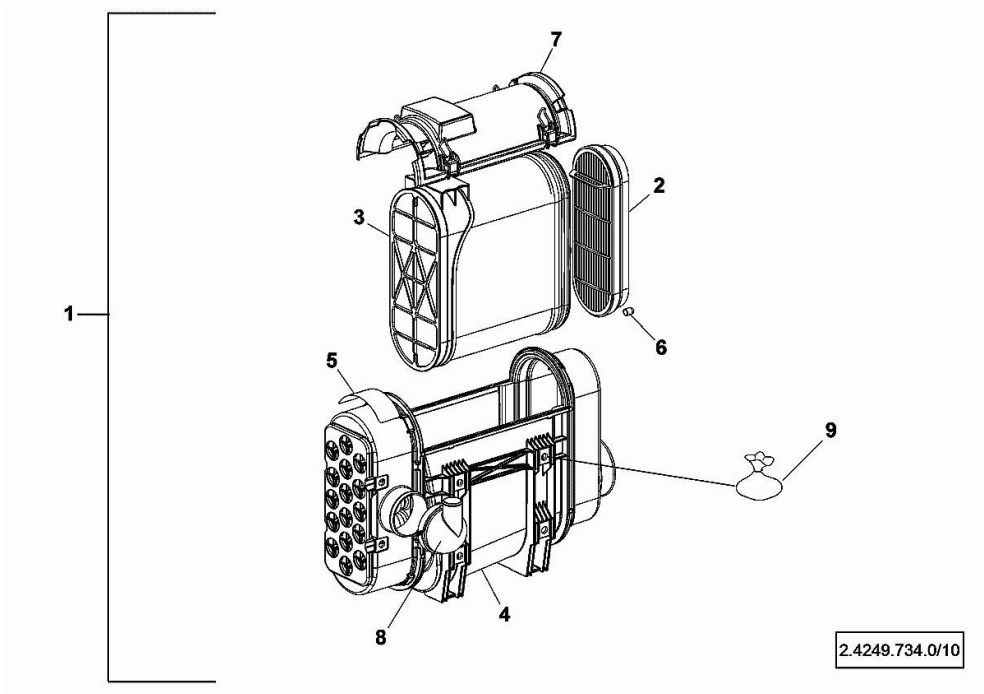

AIR FILTER 9"

Fig.	P/n	QTY	Name
1	2.4249.734.0/20	1	air filter
2	0.900.0272.1	1	internal air filter element
3	0.900.2248.1	1	filter
4	0.000.0000.1		cannot be supplied
5	0.000.0000.1	1	cannot be supplied
6	0.900.1383.8	1	guard
7	0.900.1633.5	1	cover
8	0.900.1633.6	1	exhaust valve
9	0.900.2064.4	1	accessories U-CLIP BAG

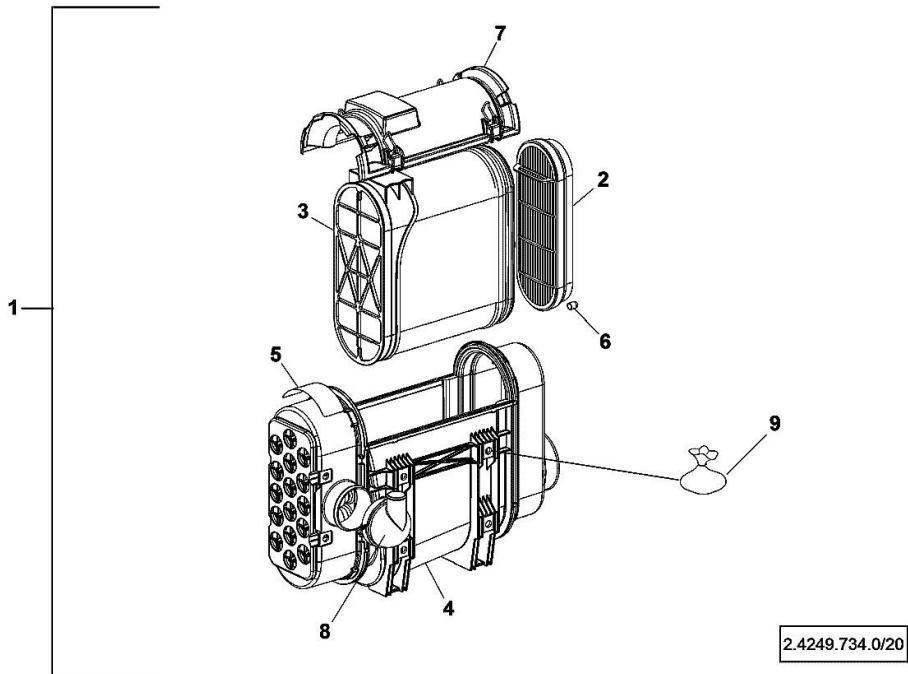

FUEL TANK SX/LH/LI

Fig.	P/n	QTY	Name
------	-----	-----	------

Notes:

[Fortis 190 ->WSXU360200LS50010]

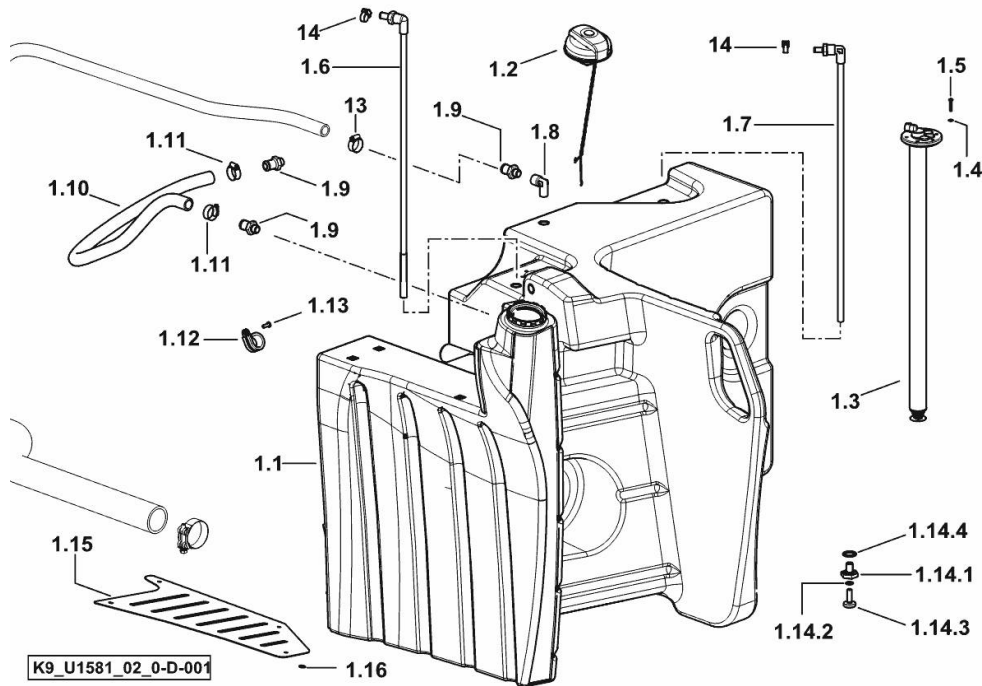

1.1	0.018.6779.3/40	1	fuel tank sx/lh/li
1.2	0.019.6285.4	1	plug (-> 50010)
1.3	2.7059.016.0	1	float
1.4	2.1310.028.2	6	flat washer
1.5	2.0332.208.2	6	screw m4x25
1.6	0.016.7111.3/20	1	tube
1.7	0.016.7518.3/10	1	tube
1.8	2.3249.224.0	1	pipe fitting Ø 22 / 3/8" GAS
1.9	2.3249.245.0	3	pipe fitting Ø 12 / 3/8" GAS
1.10	0.018.8394.0/10	1	tube
1.11	01173962	2	clamp Ø 20/32
1.12	2.6839.068.0	1	clamp Ø 27
1.13	2.0332.406.2	5	screw m 6 p.1.0 x 16
1.14.1	0.016.9607.0	1	plug m10
1.14.2	2.1560.006.0	1	gasket 10.2 x 16
1.14.3	0.016.9605.0	1	plug m14
1.14.4	2.1539.040.0	1	special oil seal 21.82 x 3.53
1.15	0.018.7319.0/20	1	guard
1.16	2.1310.002.2	4	flat washer 6.4x12.5
13	01173962	2	clamp Ø 20/32
14	2.6851.019.0	2	clamp Ø 13/20

TANK SUPPORTS SX/LH/LI

Fig.	P/n	QTY	Name
------	-----	-----	------

Notes:

[Fortis 190 ->WSXU360200LS50010]

K9_U1581_04_0-A-001

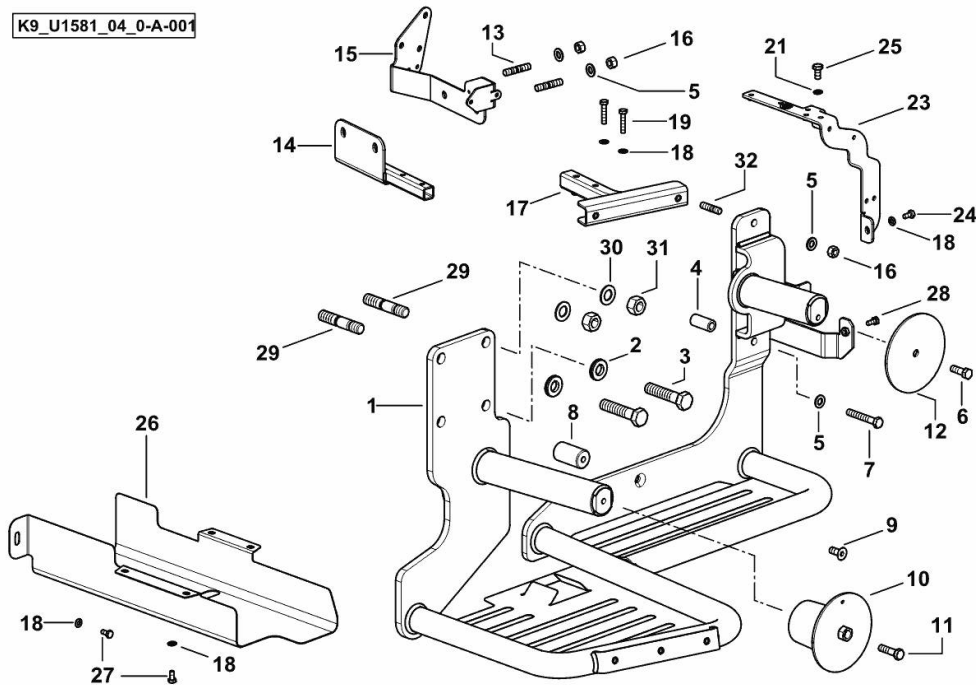

1	0.018.7363.3/30	1	bracket
2	01167055	2	washer 20.5x40
3	2.0399.302.2	2	screw m 20 p.2x90
4	04411966	1	tube
5	2.1310.007.2	4	flat washer 13 x 24
6	2.0112.413.2	1	screw m 12 p.1.75x35
7	2.0112.424.2	1	screw m 12 p.1.75x75
8	0.018.8438.0/10	1	spacer
9	2.0342.508.3	1	screw m 12 p.1.75 x 30
10	04429298.4	1	stop
11	2.0112.417.2	1	screw m 12 p.1.75 x 45
12	04413213	1	washer
13	2.0422.411.2	2	stud bolt m 12 x 1,75 x 40
14	0.018.7104.2/10	1	bracket sx/lh/li
15	0.018.7864.3/20	1	bracket
16	2.1011.107.2	3	nut m 12 p.1.75
17	0.018.7344.3/10	1	bracket sx/lh/li
18	2.1310.004.2	8	flat washer 8.4x17
19	2.0112.215.2	2	screw m 8 p.1.25 x 40
21	2.1312.005.2	6	washer 10.2
23	0.018.0226.3	1	support
23	0.020.9115.3/10	1	bracket (-> 50010)
24	2.1121.008.2	1	nut m 12
25	2.0112.307.2	1	screw m 10 p.1.5 x 20
26	0.018.4101.0	1	guard
27	2.0114.205.2	5	screw m 8 p.1.25 x 16
28	2.0112.206.2	1	screw m 8 p.1.25 x 18
29	2.0439.335.2	2	stud bolt m 20
30	2.1310.013.2	2	flat washer 21x37
31	2.1011.111.2	2	nut m 20 p.2.5
32	2.0422.407.2	1	stud bolt m 12 p.1.75x30-p.1.75x18

FUEL TANK DX/RH/RE

Fig.	P/n	QTY	Name
------	-----	-----	------

Notes:

[Fortis 190 ->WSXU360200LS50010]

7	0.018.2154.4/50	1	fuel tank dx/rh/re
7.2.1	0.016.9607.0	1	plug m10
7.2.2	2.1560.006.0	1	gasket 10.2 x 16
7.2.3	0.016.9605.0	1	plug m14
7.2.4	2.1539.040.0	1	special oil seal 21.82 x 3.53
7.3	2.3249.245.0	1	pipe fitting Ø 12 / 3/8" GAS
7.4	0.019.6285.4	1	plug (-> 50010)
8	0.015.7103.0	2	gasket 60x150x18
10	0.018.3886.0/10	1	tube
11	2.6859.155.0	2	clamp Ø 59/63
12	0.019.9244.0	1	tube
13	01173962	2	clamp Ø 20/32

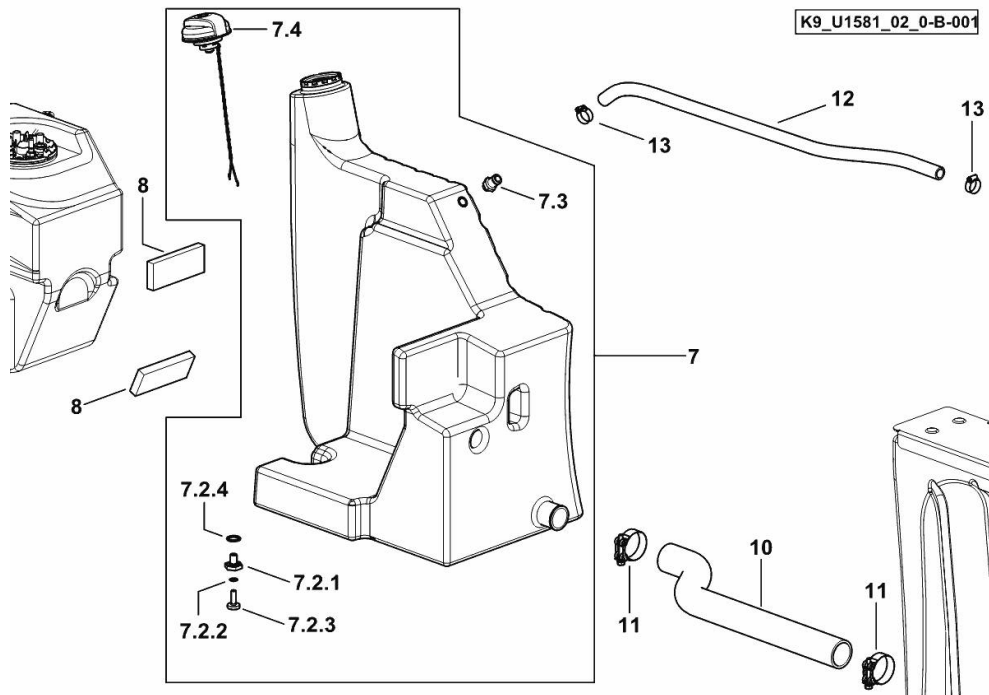



Suggest:

For more complete manuals. Please go to the home page.

<https://www.ebooklibonline.com>

If the above button click is invalid. Please download this document first, and then click the above link to download the complete manual.

Thank you so much for reading

TANK AND BATTERY SUPPORT DX/RH/RE

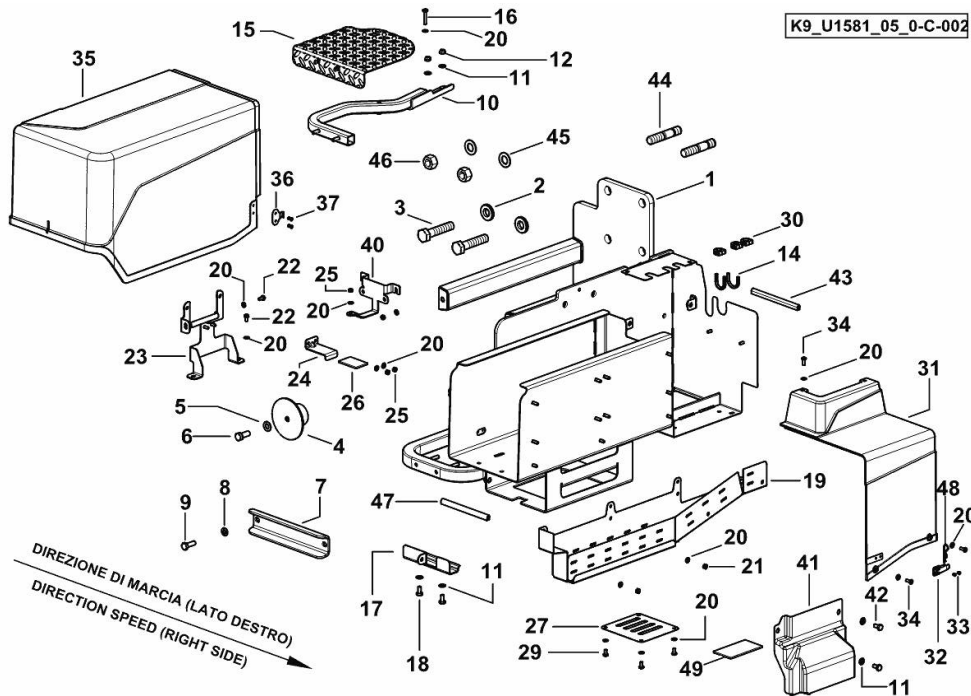

Fig.	P/n	QTY	Name
------	-----	-----	------

Notes:

[Fortis 190 ->WSXU360200LS50010]

1	0.018.2320.3/70	1	support dx/rh/re (50010 <-)
1	0.018.2320.3/80	1	support dx/rh/re
2	01167055	2	washer 20.5x40
3	2.0399.302.2	2	screw m 20 p.2x90
4	0.018.1844.2	1	bracket dx/rh/re
5	2.1310.007.2	1	flat washer 13 x 24
6	2.0112.411.2	1	screw m 12 p.1.75 x 30
7	0.018.2847.0	1	bracket dx/rh/re
8	2.1310.006.2	2	flat washer 10.5x21
9	2.0112.311.2	2	screw m 10 p.1.5 x 30
10	0.018.2954.3/20	1	bracket
11	2.1310.004.2	10	flat washer 8.4x17
12	2.1121.005.2	6	nut m 8 p.1.25
14	01393059	0.16	gasket
15	0.018.1397.0/30	1	foot board dx/rh/re
16	2.0332.410.2	1	screw m 6 p.1 x 35
17	0.015.2140.3/10	1	bracket
18	2.0114.205.2	2	screw m 8 p.1.25 x 16
19	0.018.3419.3	1	bracket
20	2.1310.002.2	21	flat washer 6.4x12.5
21	2.1011.003.2	3	nut m 6 p.1, d934
22	2.0112.003.2	4	screw m 6 p.1 x 12
23	0.018.8462.3	1	bracket
24	0.016.4712.0	1	bracket
25	2.1011.103.2	5	nut m 6 p.1
26	0.016.4901.0	1	gasket
27	0.018.4108.0/10	1	guard
29	2.0332.203.2	4	screw m 4 x 10
30	2.6569.081.0	3	wire guide
31	0.018.3917.0/10	1	cover
32	0.014.7214.0	2	closure
33	2.1899.090.0	4	rivet 3x8
34	2.0332.406.2	4	screw m 6 p.1.0 x 16
35	0.018.2405.0/10	1	cover
36	0.015.2116.0	2	hook
37	2.1856.004.0	4	rivet 4
40	0.018.8804.0	1	bracket
41	0.018.9458.0	1	guard
42	2.0112.205.2	2	screw m 8 p.1.25 x 16
43	0.019.2929.0	1	gasket
44	2.0439.335.2	2	stud bolt m 20

TANK AND BATTERY SUPPORT DX/RH/RE

Fig.	P/n	QTY	Name
45	2.1310.013.2	2	flat washer 21x37
46	2.1011.111.2	2	nut m 20 p.2.5
47	0.018.0981.0	1	gasket
48	2.1699.180.2	2	pin
49	0.016.4909.0	1	gasket

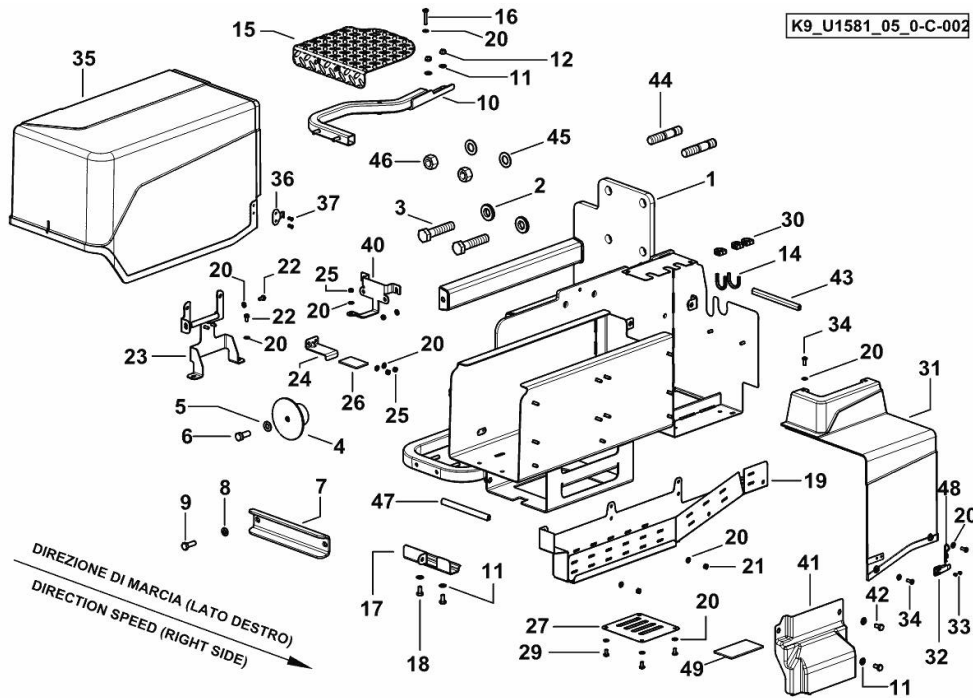

<https://www.ebooklibonline.com>

Hello dear friend!

Thank you very much for reading.

Enter the link into your browser.

The full manual is available for immediate download.

<https://www.ebooklibonline.com>