

Section: ENGINE
CRANKCASE

Fig.	P/n	QTY	Name
------	-----	-----	------

Notes:
[EXPLORER II 80]

1	0.087.0050.6/10		gasket set - FOR ENGINE MOUNTING
2	0.066.1130.0/20	1	flange
3	2.0112.511.2	8	screw m 14 p.2 x 30
8	2.1099.108.2	4	special nut m 10 p.1
9	2.1560.006.0	8	gasket 10.2 x 16
10	0.086.1550.2	4	sprayer nozzle
11	0.065.1160.3/20	4	valve
12	2.1539.047.0	1	special oil seal 26.7x1.78
13	2.3199.405.2	1	plug m 28 p.1.5
16	2.0432.003.7	12	stud bolt m 8 p.1.25 / p.1 x 20
19	2.1519.096.0/20	4	special oil seal 107.67x1.78 26012 <= X 70HP - 80HP 6768 <= X 90HP
19	2.1539.130.0/10	4	special oil seal 117.07x3.53 => 26013 X 70HP - 80HP => 6769 X 90HP
20	0.007.0762.0/50	4	engine cylinder => 26013 X 70HP - 80HP => 6769 X 90HP
20	0.085.1120.0/10	4	engine cylinder 26012 <= X 70HP - 80HP 6768 <= X 90HP
25	0.066.1152.0/10	4	gasket
26	0.007.1140.6/10	1	crankcase => 26013 X 70HP - 80HP => 6769 X 90HP
26	0.086.1110.6	1	crankcase 26012 <= X 70HP - 80HP 6768 <= X 90HP
27	0.065.1112.7	1	support
28	2.1699.165.0	1	bush 12.3x15x16
29	0.065.1116.3	1	support
30	2.1699.165.0	1	bush 12.3x15x16
31	0.066.1151.0	1	pin
32	0.065.1141.0	1	special bushing 59X55X30
33	0.065.1140.0	4	special bushing 59X55X20
34	2.3179.012.0	1	plug 60
35	2.3130.001.1	11	plug 1/8" gas
36	2.3130.002.1	2	plug 1/4" gas
37	2.3130.003.1	7	plug 3/8" gas

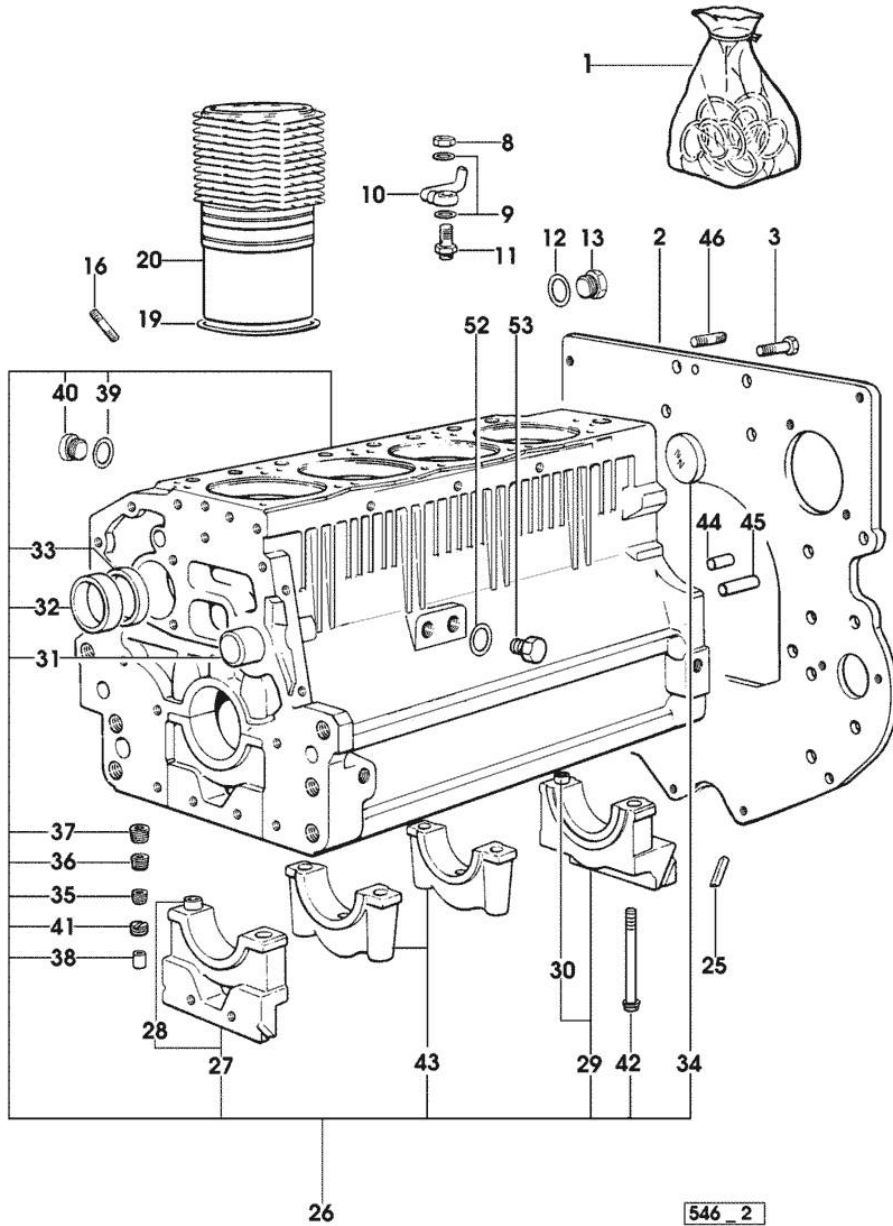

Section: ENGINE
CRANKCASE

Fig.	P/n	QTY	Name
38	2.3199.092.0	4	plug 8 x 12
39	2.1560.017.0	1	gasket 22.2 x 27 (...) <=
40	2.3120.002.4	1	plug m 22 x 1.5 (...) <=
41	2.1324.011.0	1	plug
42	0.065.1117.0	10	screw m 12 x 100
43	0.065.1114.0/10	3	support
44	2.1651.912.0	2	cylindrical plug 12x28
45	2.1651.917.0	1	cylindrical plug 12x40
46	2.0432.255.7	2	stud bolt m 12 p.1.75-1.25x25
52	2.1560.017.0	1	gasket 22.2 x 27
53	2.3120.002.4	1	plug m 22 x 1.5

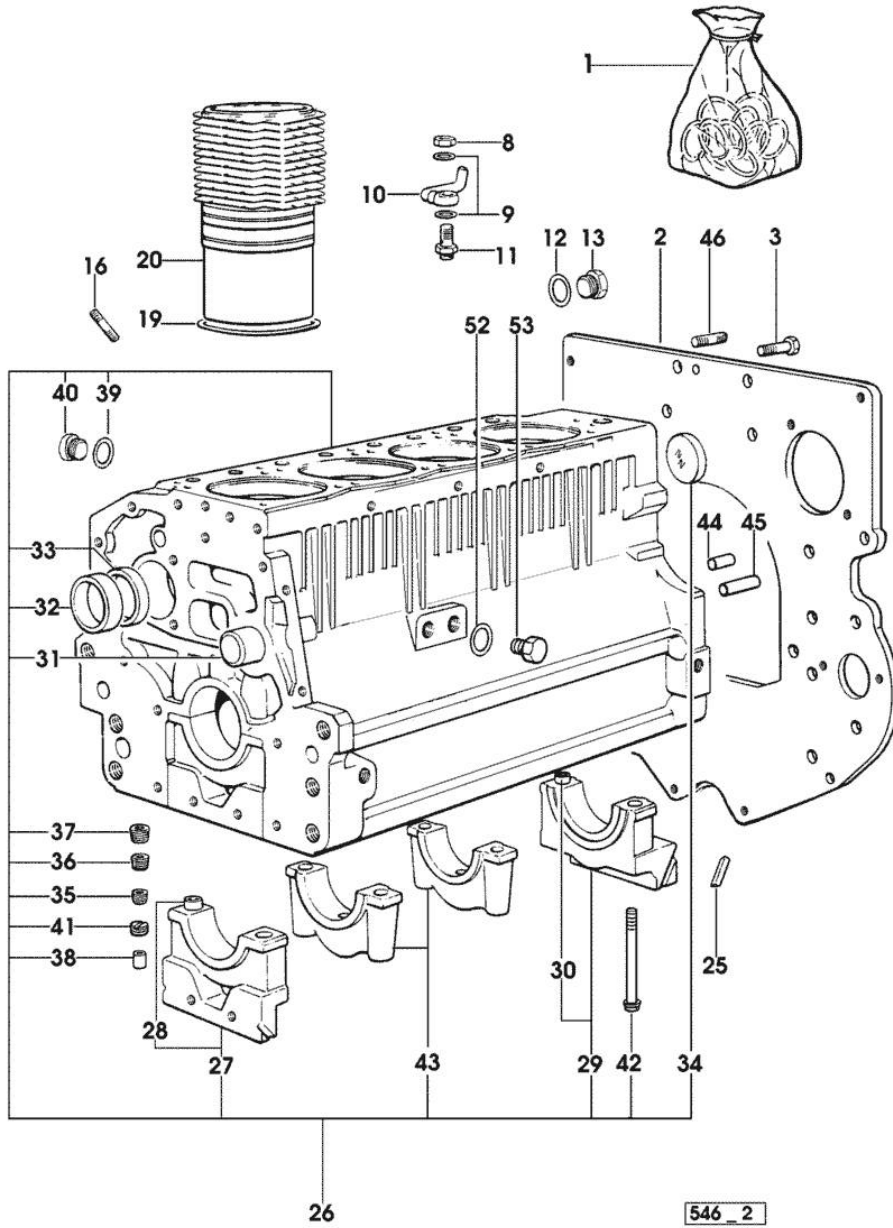

Section: ENGINE

TIMING CASE

Fig.	P/n	QTY	Name
------	-----	-----	------

Notes:

[EXPLORER II 80]

1	0.007.1262.3/50	1	guard
2	0.007.1271.0/10	1	small column m 8 p.1.25 / L = mm 60
3	0.007.1272.0/10	2	small column m 8 p.1.25 / L = mm 50
5	2.1310.004.2	3	flat washer 8.4x17
7	2.0112.205.2	3	screw m 8 p.1.25 x 16

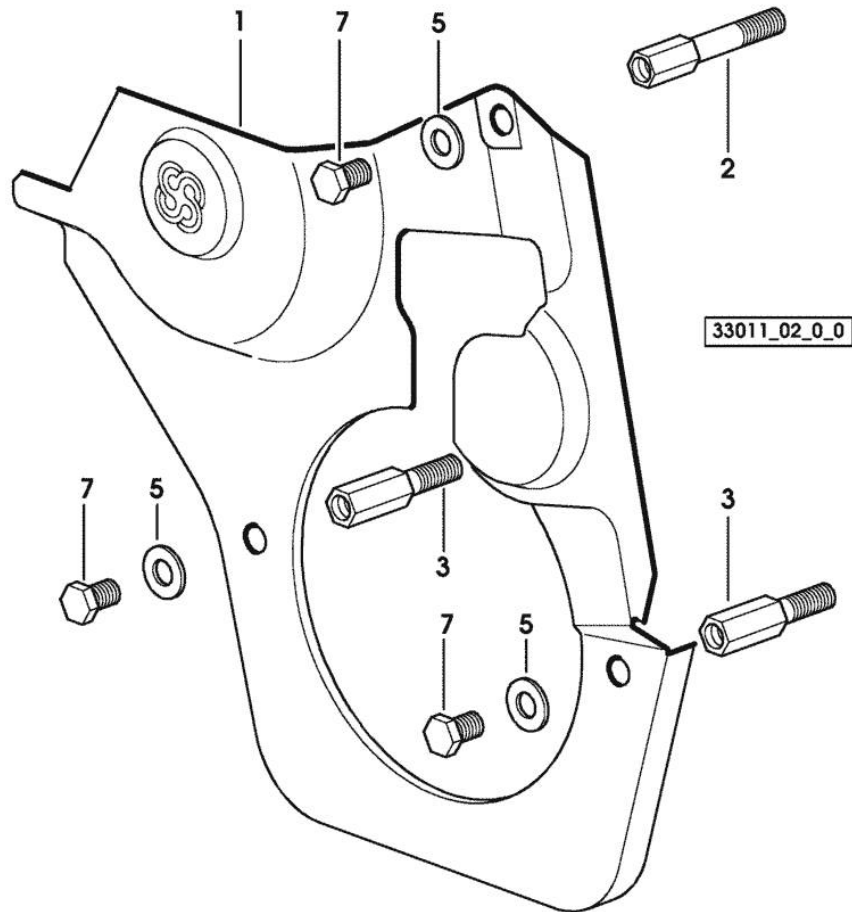

<https://www.ebooklibonline.com>

Hello dear friend!

Thank you very much for reading.

Enter the link into your browser.

The full manual is available for immediate download.

<https://www.ebooklibonline.com>

Section: ENGINE

TIMING CASE

Fig.	P/n	QTY	Name
------	-----	-----	------

Notes:
[EXPLORER II 80]

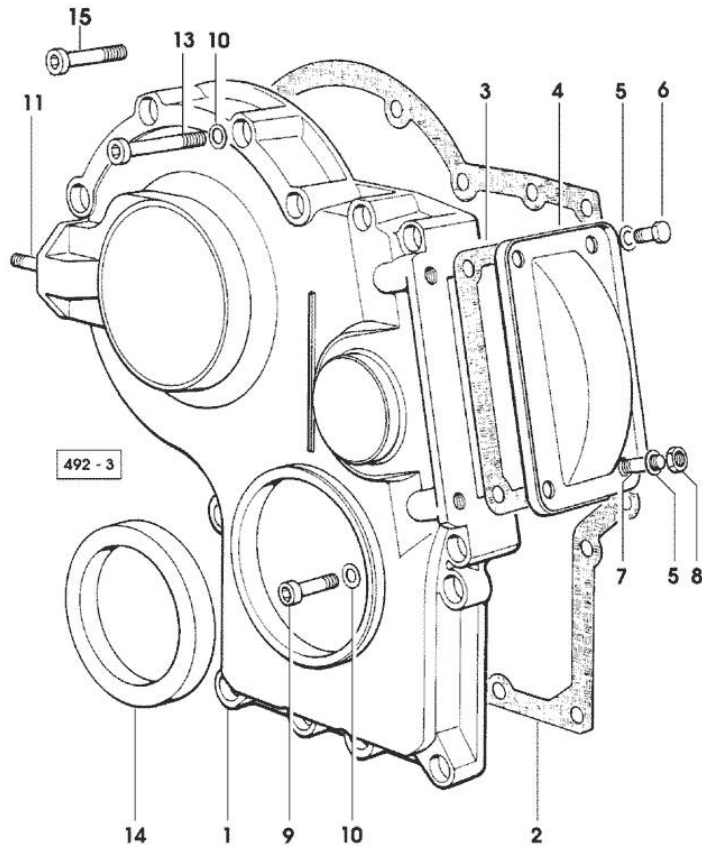

1	0.065.1132.0/60	1	guard
2	0.065.1150.0/30	1	gasket
3	0.065.1152.0	1	gasket
4	0.065.1151.0	1	cover
5	2.1470.004.2	4	lock washer 8
6	2.0112.205.2	2	screw m 8 p.1.25 x 16
7	2.0432.003.7	2	stud bolt m 8 p.1.25 / p.1 x 20
8	2.1011.405.2	2	nut m 8 p.1
9	2.0312.208.2	8	screw m 8 p.1.25 x 25
10	2.1480.014.1	15	washer 8
11	2.0432.003.7	2	stud bolt m 8 p.1.25 / p.1 x 20
13	2.0312.214.2	3	screw m 8 p.1.25 x 40
14	2.1529.141.0	1	special oil seal
15	2.0312.219.2	4	screw m 8 p.1.25x65

Section: ENGINE

CRANKSHAFT

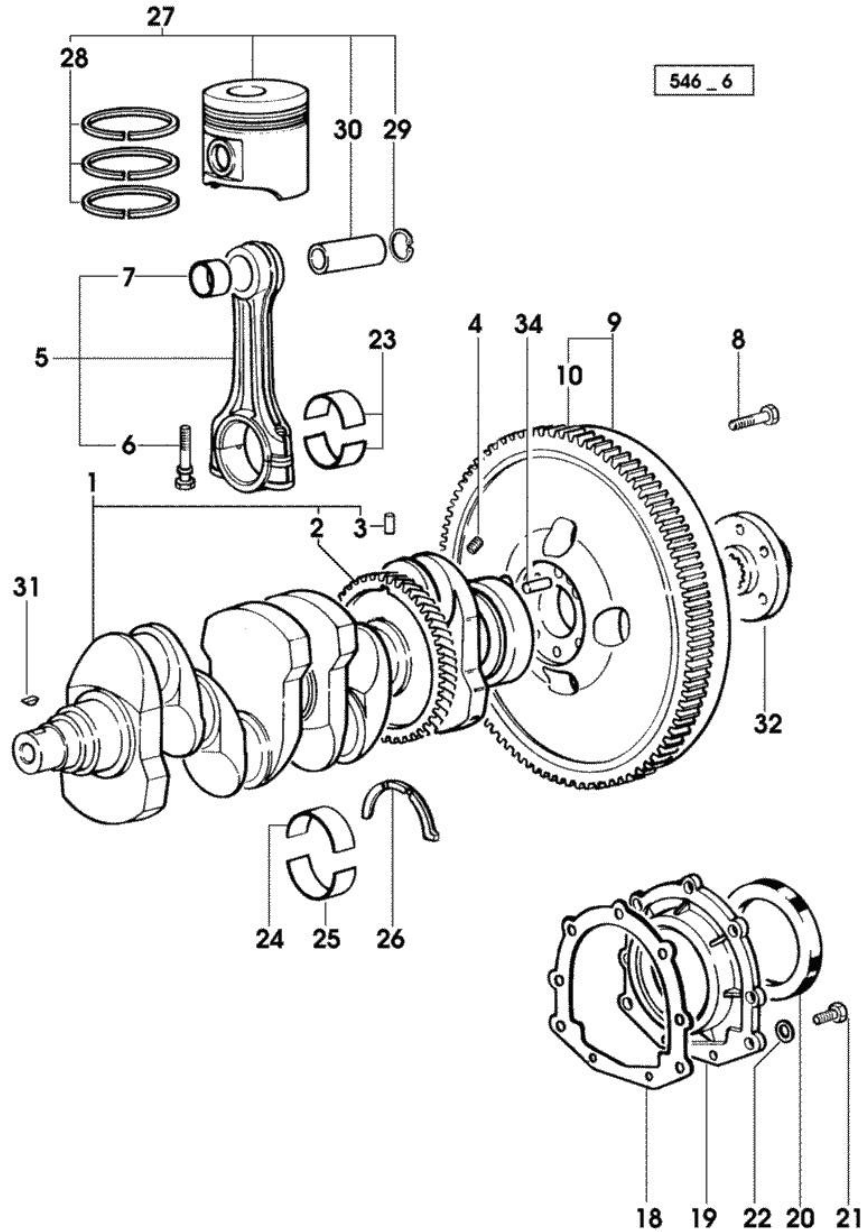

Fig.	P/n	QTY	Name
Notes: [EXPLORER II 80]			
1	0.086.1210.3/30	1	crankshaft * 31067 <= X 80HP * 8304 <= X 90HP - N.1 - 007.1711.0/10 - N.4 - 2.3130.001.1
2	0.065.1211.0/10	1	crown wheel
3	2.1630.608.0	1	pin 6x16
4	2.3130.001.1	4	plug 1/8" gas
5	0.078.1220.3/30	4	engine connecting rod
6	2.0399.213.0	8	screw m 12 p.1.25x61.5
7	2.1559.114.0/10	4	special bushing
8	2.0139.022.2	6	screw m 12 p.1.25x55
9	0.007.1702.3/30	1	flywheel -> 23180 X 80HP -> 24976 X 90HP
9	0.008.4049.3	1	flywheel mm 373 -> 22689 - 23179 <- X 80HP -> 24226 - 24975 <- X 90HP
9	0.076.1247.3/20	1	flywheel 22688 <- X 80HP 24225 <- X 90HP
10	0.065.1242.0	1	crown wheel Z = 123
18	0.065.1254.0/20	1	gasket
19	0.007.1711.0/10	1	cover => 31068 X 80HP => 8305 X 90HP
19	0.065.1253.0/20	1	cover 31067 <= X 80HP 8304 <= X 90HP
20	2.1529.073.0	1	special oil seal 110x130x13
21	2.0112.207.2	9	screw m 8 p 1.25 x 20
22	2.1475.002.2	9	conical washer 8
23	0.065.1225.0	8	con.rod half bushing STANDARD - A = 28.75 -> 29.00
23	0.065.1225.7		con.rod half bushing - mm 0.25
23	0.065.1225.8		con.rod half bushing - mm 0.50
24	0.065.1215.0	5	main half bushing STANDARD
24	0.065.1215.7		main half bushing - mm 0.25
24	0.065.1215.8		main half bushing - mm 0.50
25	0.065.1216.0	5	main half bushing
25	0.065.1216.7		main half bushing - mm 0.25
25	0.065.1216.8		main half bushing - mm 0.50
26	0.065.1218.0	4	shim STANDARD

Section: ENGINE

CRANKSHAFT

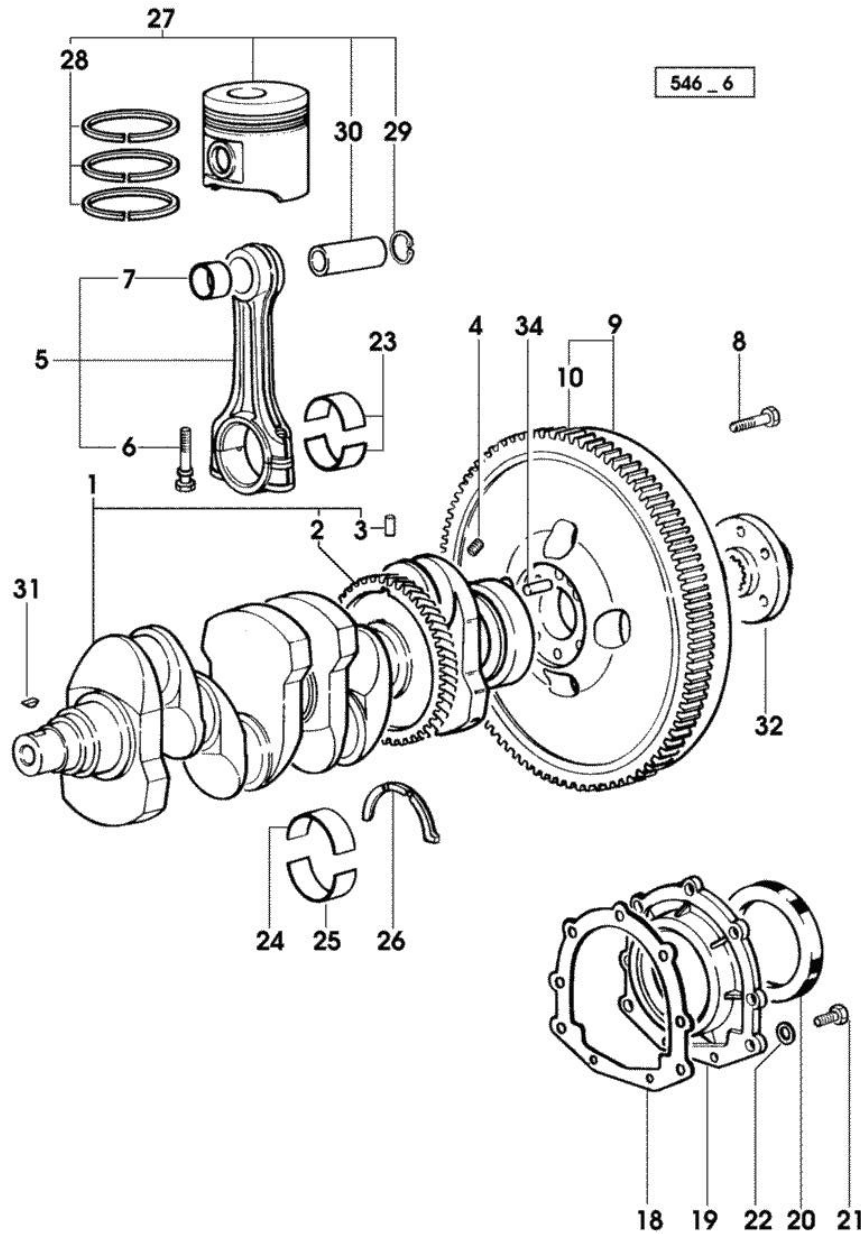

Fig.	P/n	QTY	Name
26	0.065.1218.7		shim + mm 0.10
26	0.065.1218.8		shim + mm 0.15
27	0.086.0060.6/30	4	complete piston - X 80HP
27	0.338.0060.6/20	4	complete piston - X 90HP
27	0.381.0060.6	4	complete piston - X 90HP - EXPORT U.S.A.
28	0.081.0090.6/10	4	piston ring set 6768 <= X 90HP - TORSIONAL
28	0.086.0052.6/10	4	piston ring set - X 80HP
28	0.338.0052.6/10	4	piston ring set => 6769 X 90HP - X 90HP - EXPORT U.S.A. - TRAPEZOIDAL
29	2.1411.014.1	8	circlip 35
30	0.078.1236.0	4	piston pin Ø 18 / Ø 35 / L = mm 86
31	2.1720.006.0	3	key 4x6.5
32	0.008.5543.0	1	flange -> 22689 X 80HP -> 24226 X 90HP
32	0.255.2525.0/10	1	flange 22688 <- X 80HP 24225 <- X 90HP
34	2.1652.915.0	1	cylindrical plug 12x35

Section: ENGINE

ENGINE SHAFT - PULLEYS

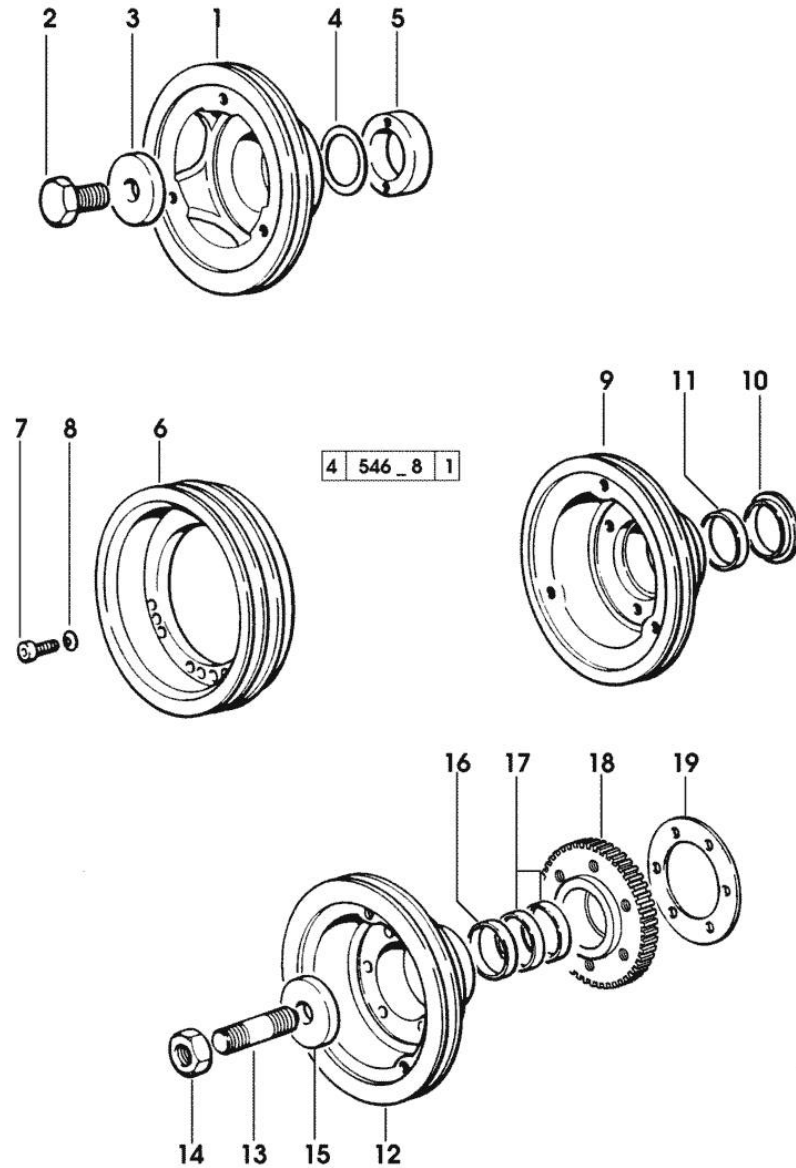

Fig.	P/n	QTY	Name
Notes:			
[EXPLORER II 80]			
1	0.007.1330.0/30	1	pulley
2	2.0399.144.7/10	1	screw m 20 p.1.5x51 * (...) <=
			- N.1 - 2.1599.524.7
3	2.1599.524.7	1	washer 21x60x12 * (...) <=
			- N.1 - 2.0399.144.7
4	2.1589.189.0	3	shoulder ring mm 1.00
5	0.085.1248.0/10	1	hub
6	0.086.1251.0	1	pulley - FOR ACCESSORIES
7	2.0312.308.1	3	screw m 10 p.1.5 x 25
8	2.1480.015.1	3	washer 10
9	0.085.1253.0/10	1	pulley (...) <=
			- FOR P.T.O. FRONT
10	0.085.1254.0	1	ring
11	0.065.1256.0	1	ring 45x52
12	0.086.1244.0	1	pulley => (...)
			- FOR P.T.O. FRONT
13	2.0439.195.7	1	stud bolt m 20 p.1.5x80
14	2.1019.094.7	1	nut m 20 p.1.5
15	2.1599.524.7	1	washer 21x60x12
16	2.1579.865.0	1	spacer 45.2x51.8x10
17	0.065.1256.0	2	ring 45x52
18	0.011.3515.0/10	1	hub Z = 48
19	2.1589.136.0	3	shoulder ring 71x110x0.5
19	2.1589.137.0	1	shoulder ring 71x110x1

Section: ENGINE

COUNTERWEIGHTS

Fig.	P/n	QTY	Name
------	-----	-----	------

Notes:
[EXPLORER II 80]

1	0.086.1233.3/30	1	mass sx/lh/li
2	2.1559.115.0	2	special bushing 26x30x30
3	2.1652.302.0	1	roll pin 4x6
4	0.000.0000.1		cannot be supplied
5	0.065.1233.3/30	1	mass dx/rh/re
6	2.1410.018.7	1	circlip 45
7	2.1652.302.0	1	roll pin 4x6
8	2.1559.115.0	2	special bushing 26x30x30
9	0.000.0000.1		cannot be supplied
10	2.1589.185.0	4	shoulder ring 26.1x34x1
11	2.1631.717.0	2	roll pin 8 x 40
12	0.086.1231.0/10	1	box
13	2.3130.001.1	4	plug 1/8" gas
14	2.0139.028.2	4	screw m 12
15	2.1579.628.0	2	spacer 16.5x26x0.1
15	2.1589.048.0	2	shoulder ring 16.5x26x0.3
16	2.1579.629.0		spacer 12.5x26x0.1
16	2.1589.049.0		shoulder ring 12.5x26x0.3
17	2.1579.626.0	2	spacer 13.2x16x11
18	2.1589.139.0	2	shoulder ring mm 0.3
19	2.1589.140.0	2	shoulder ring mm 0.1
20	2.1699.191.0	1	bush 7x10x16
21	0.065.1234.0/10	2	shaft
22	2.3130.001.1	2	plug 1/8" gas

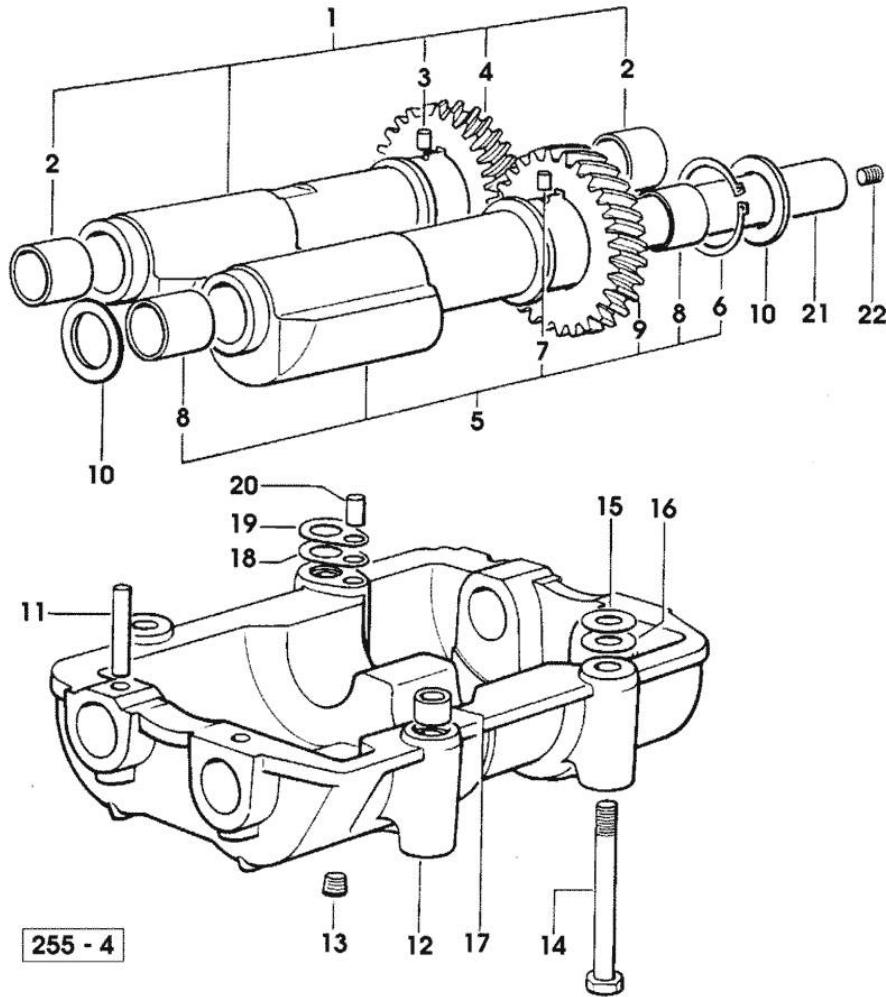

Section: ENGINE

CAMSHAFT

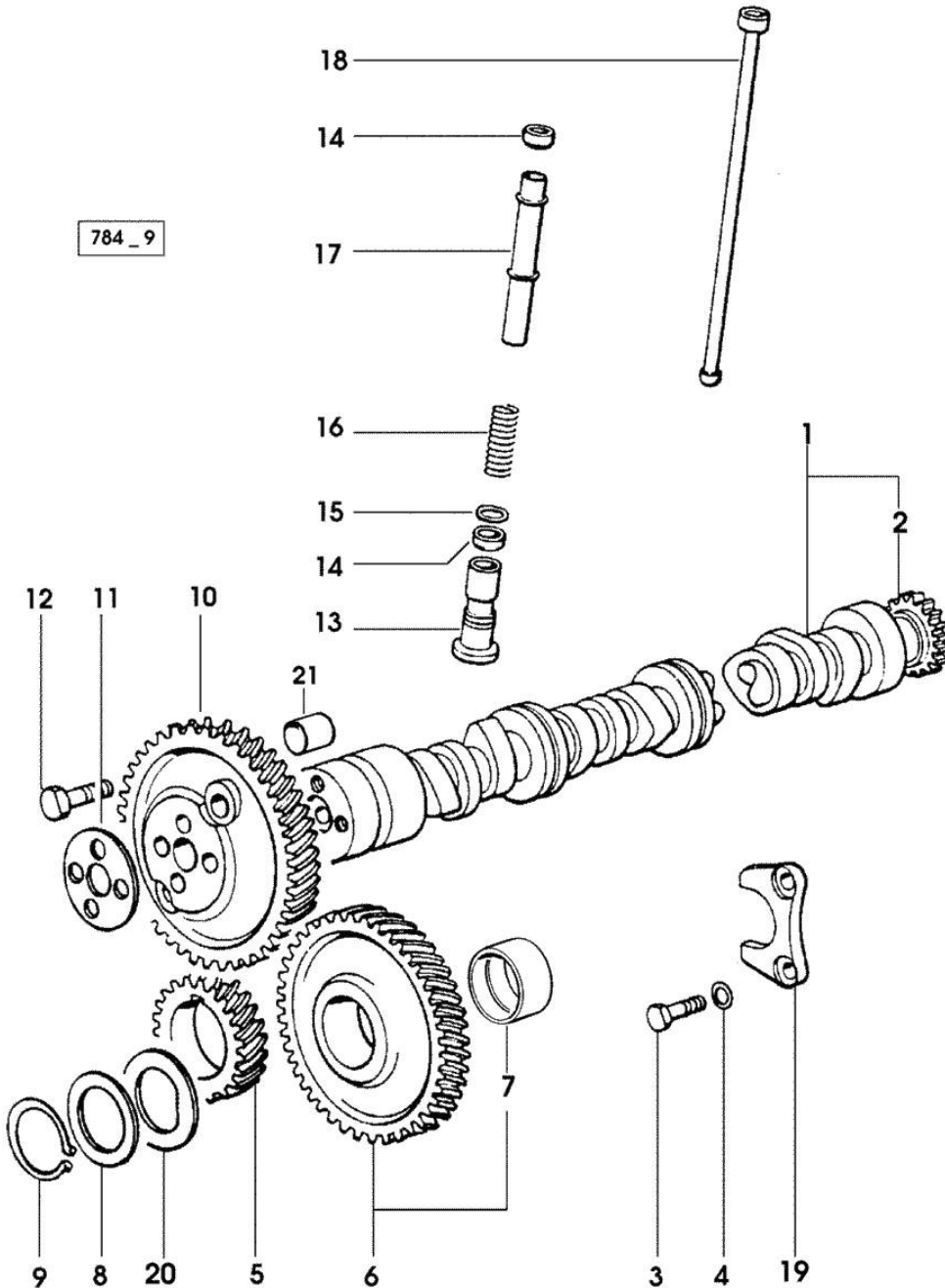

Fig.	P/n	QTY	Name
------	-----	-----	------

Notes:
[EXPLORER II 80]

1	0.007.1712.3/10	1	camshaft - EXPORT U.S.A.
1	0.066.1310.3/40	1	camshaft
2	0.065.1324.0/10	1	gear Z = 32
3	2.0312.206.2	2	screw m 8 p 1.25 x 20
4	2.1480.014.1	2	washer 8
5	0.065.1323.0/30	1	gear Z = 29
6	0.007.1177.3/10		gear z = 57 - WITH RED IDENTIFICATION STAMP
6	0.007.1178.3/10		gear z = 57 - WITH YELLOW IDENTIFICATION STAMP
6	0.007.1179.3/10		gear z = 57 - WITH GREEN IDENTIFICATION STAMP
7	2.1559.185.0/10	1	bushing
8	0.065.1352.0	1	shim
9	2.1410.016.1	1	circlip 40
10	0.065.1354.0/20	1	gear z=58
11	0.065.1350.0	1	small disc
12	2.0132.207.2	4	screw m 10 p.1 x 25
13	0.065.1330.0	8	tappets
14	2.1569.114.0/10	16	gasket 14x18.5x8
15	2.1599.437.0	8	shoulder ring
16	2.4019.300.1/10	8	spring 18.5x52x2
17	0.065.1332.0	8	sleeve
18	0.065.1331.2	8	rod
19	0.065.1353.0	1	small plate
20	0.065.1351.0	2	shoulder ring
21	2.1559.398.0	1	bushing 10.5x13x12

Section: ENGINE
CYLINDER HEAD

Fig.	P/n	QTY	Name
------	-----	-----	------

Notes:
[EXPLORER II 80]

1	2.0399.130.2	4	screw m 8 x 30 39125 <= X 70HP - 80HP 11244 <= X 90HP
1	2.0399.130.2/10	4	screw m 8x36x44 => 39126 X 70HP - 80HP => 11245 X 90HP
2	2.1569.170.0/10	4	gasket 8.2 x 14
3	0.007.1139.0/10	4	small cap * 39125 <= X 70HP - 80HP * 11244 <= X 90HP - N.1 - 2.0399.130.2/10
4	0.065.1450.0/30	1	tappet gasket
5	2.1011.321.2	8	nut m 10 p.1.25
6	2.0432.163.7	8	stud bolt m 10 p.1.5 / p.1.25 x 45
7	0.066.1430.0/10	4	support
8	0.066.1432.3	8	rocker arm
9	2.1559.021.0/40	8	bushing 15x19x22
10	2.1410.055.1	8	circlip 19
11	2.1011.405.2	8	nut m 8 p.1
12	0.021.1434.0	8	screw
13	0.074.1423.0	8	conical valve cotter
14	0.066.1425.0	8	cup
15	2.4019.287.0	8	spring
16	0.065.1413.0/10	4	bush L = mm 97.1 27322 <= X 70HP - 80HP 7149 <= X 90HP
17	2.0432.161.7	4	stud bolt m 10 p.1.5 / p.1.25 x 40
18	0.065.1443.0/20	16	screw
20	2.0432.007.2	8	stud bolt m 8 p.1.25 / p.1 x 30
21	0.085.1450.0		head gasket mm 0.5 -A-
21	0.085.1451.0		head gasket mm 0.7 -B-
21	0.085.1452.0		head gasket mm 1.0 -C-
21	0.085.1453.0		head gasket mm 0.8 -D-
22	0.010.6022.0	4	exhaust valve mm 39.1 / Ø mm 9 - X 90HP -> (...) = B
22	0.066.1421.0	4	exhaust valve - X 70HP - 80HP - X 90HP (...) <= A
23	0.010.6016.0	4	inlet valve mm 43.63 / Ø mm 9 - X 70HP - 80HP
23	0.010.6017.0	4	inlet valve mm 43.63 / Ø mm 9

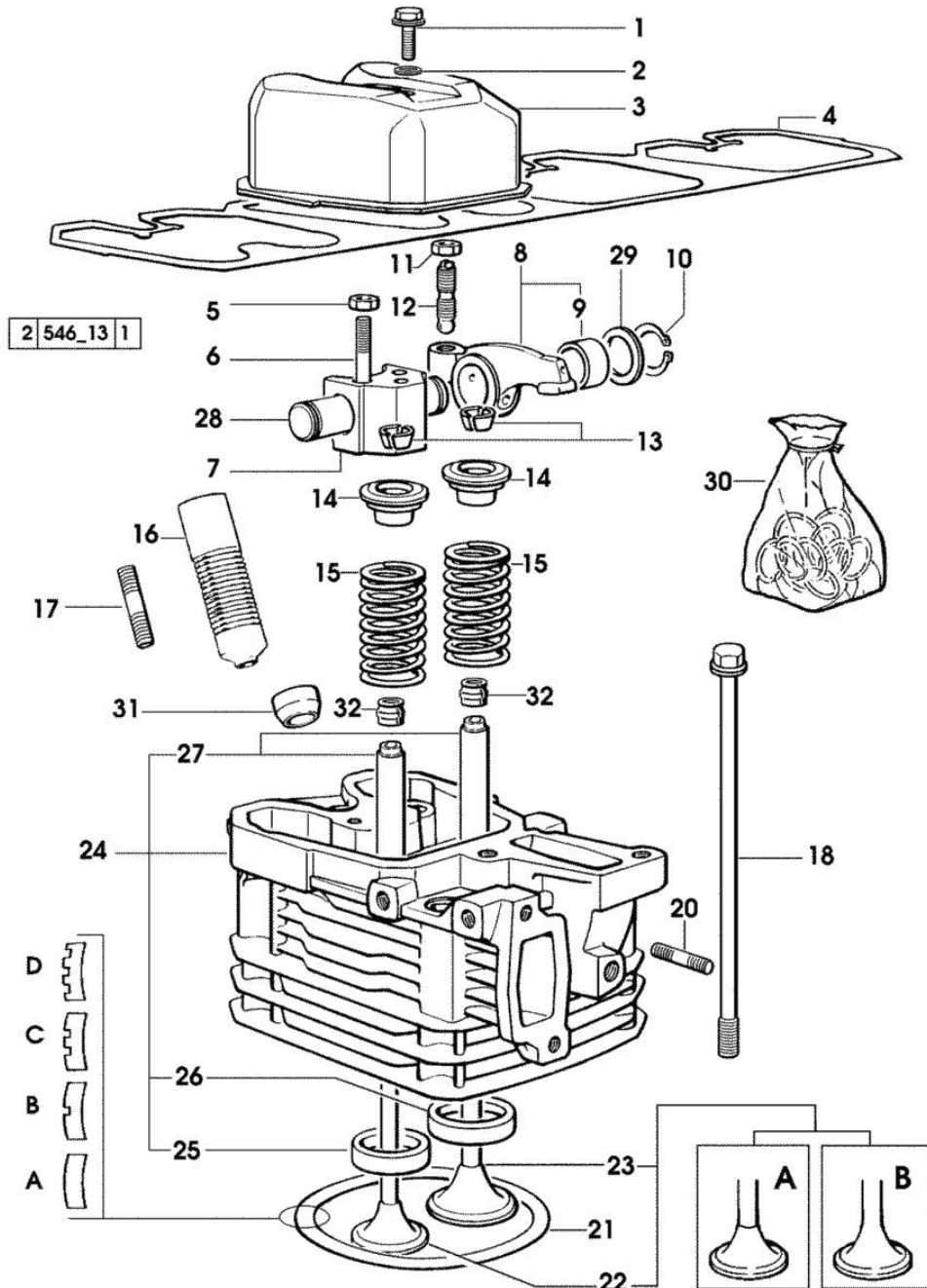

Section: ENGINE
CYLINDER HEAD

Fig.	P/n	QTY	Name
23	0.081.1420.0	4	- X 90HP -> (...) = B inlet valve Ø mm 9
24	0.007.1110.3/50	4	- X 90HP (...) <= A engine head * 27322 <= X 70HP - X 80HP * 7148 <= X 90HP - N.1 - 007.1122.0/10 - X 90HP (...) <= A
24	0.007.1359.3/50	4	engine head - X 90HP -> (...) = B
25	0.066.1427.0	4	valve seat
26	0.078.1426.0	4	valve seat
27	0.007.1779.0/10	8	valve guide
28	0.066.1431.0	4	pin
29	2.1599.432.0	8	shoulder ring
30	0.085.0057.6/10		gasket set - FOR 1 CYLINDER VALVE GRINDING AND PISTON RINGS REPLACEMENT
31	0.007.1122.0/10	4	bush L = mm 6.4 => 27323 X 70HP - 80HP => 7149 X 90HP
32	2.1519.117.0	8	special oil seal

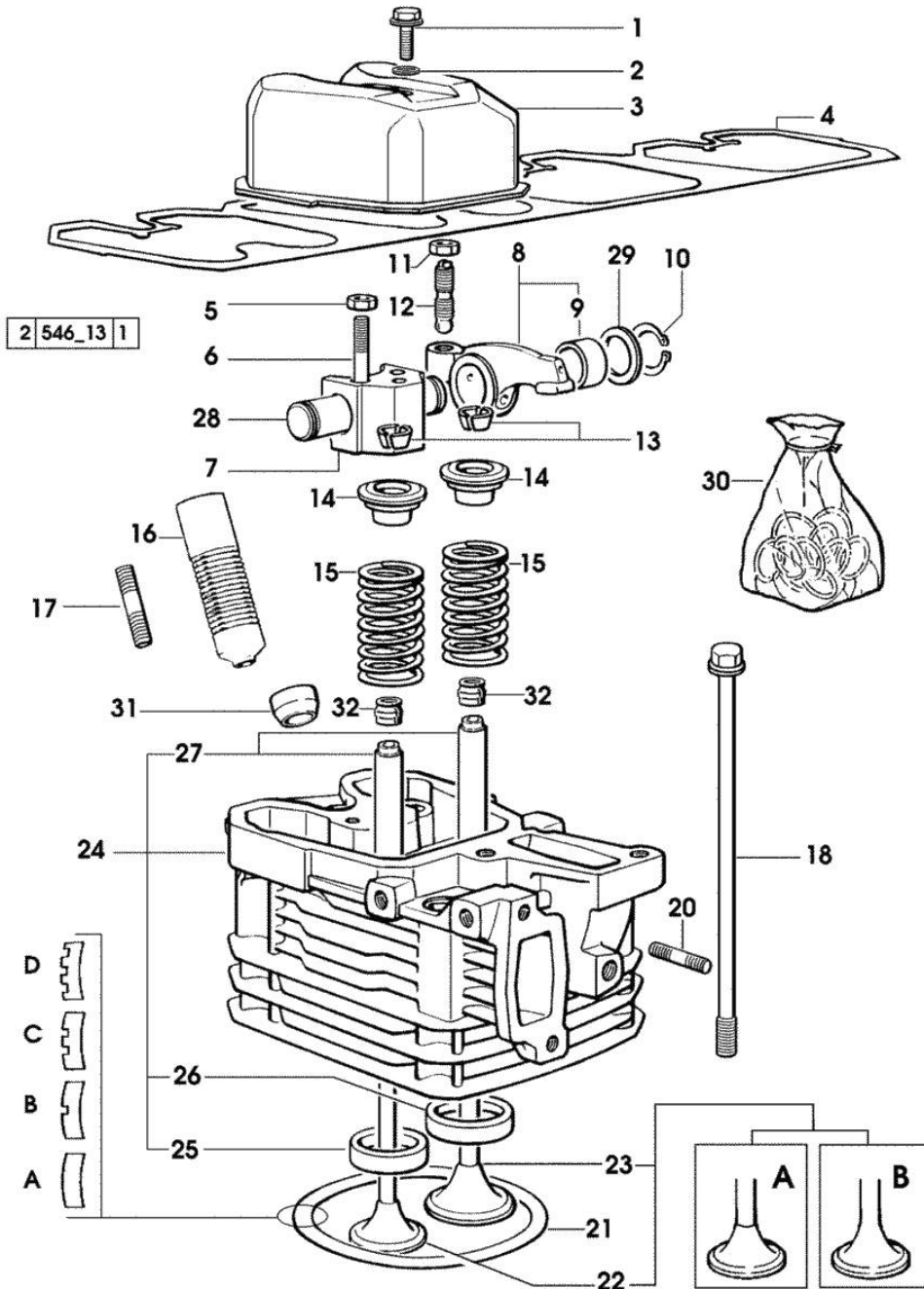

Section: ENGINE
LUBRICATION

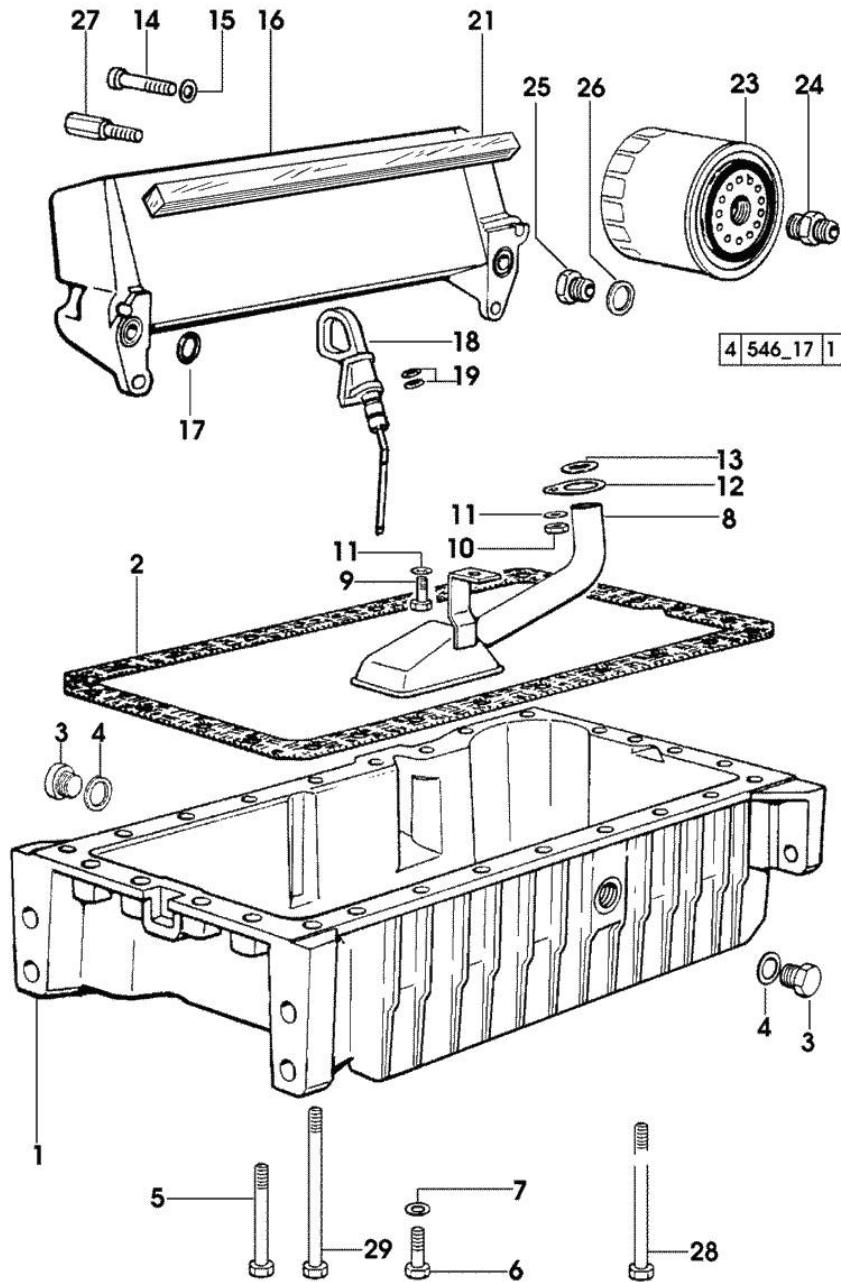

Fig.	P/n	QTY	Name
------	-----	-----	------

Notes:
[EXPLORER II 80]

1	0.007.1277.0/40	1	oil sump
2	0.065.1550.0/10	1	gasket
3	2.3199.001.2	2	plug 1/2" gas
4	2.1560.054.0	2	gasket 21 x 26
5	2.0112.226.2	4	screw m 8 p.1.25 x 85
6	2.0112.215.2	17	screw m 8 p.1.25 x 40
7	2.1470.004.2	26	lock washer 8
8	0.065.1531.3/20	1	tube
9	2.0112.205.2	1	screw m 8 p.1.25 x 16
10	2.1011.105.2	1	nut m 8 p.1.25
11	2.1470.004.2	2	lock washer 8
12	0.065.1538.0	1	flange
13	2.1539.040.0	1	special oil seal 21.82 x 3.53
14	2.0312.216.2	2	screw m 8 p.1.25x50
15	2.1310.004.2	2	flat washer 8.4x17
16	0.007.7320.3	1	oil cooler
16	0.065.1540.3/20	1	oil cooler
17	2.1539.048.0	2	special oil seal 20.35x1.78
18	0.086.1513.2/30	1	dipstick
19	2.1539.065.0	2	special oil seal 8.73 x 1.78
21	0.052.1856.0	2	gasket
23	0.044.1567.0	1	oil filter element
23	2.4419.340.0	1	oil filter element
24	2.3339.307.0	1	pipe fitting m 22 p.1.5-3/4"
25	2.3339.353.2/20	1	pipe fitting 12 p.1.5-18 p.1.5
26	2.1560.014.0	1	washer 18.2 x 24
27	2.0399.113.2/10	2	screw
27	2.0399.125.2/10	2	screw m 8 x 55
28	2.0112.235.2	3	screw m 8 p.1.25 x 130
29	2.0112.239.2	2	screw m 8 p.1.25 x 150

Section: ENGINE
LUBRICATION

Fig.	P/n	QTY	Name
------	-----	-----	------

Notes:
[EXPLORER II 80]

1	2.0312.206.2	2	screw m 8 p 1.25 x 20
2	2.1480.014.1	2	washer 8
3	0.041.1135.4	1	plug 1" gas
4	2.1569.072.0	1	gasket 32 x 39.5 x 2
5	0.065.1565.0/10	1	pipe union
6	0.010.5441.4/10	1	oil pump - X 70HP - 80HP - 90HP
6	0.010.5481.4	1	oil pump - X 60HP
7	0.065.1552.3/60	1	valve
8	2.1539.042.0	1	special oil seal 47.35x1.78
9	2.1651.711.0	2	pin 8 x 14
10	2.0169.005.2	2	screw m 6 p.1 x 12
11	0.065.1569.0/40	1	shaft
12	2.1470.006.2	2	lock washer 10
13	2.0112.325.2	2	screw m 10 p.1.5 x 80
14	0.065.1560.0/20	2	gasket
15	0.065.1562.0/10	1	joint
16	0.075.1551.4/20	1	support
17	2.2020.001.0	1	ball bearing 15 x 32 x 8.00
18	2.2725.016.0	1	roller cage 15 x 21 x 12
19	2.2680.020.0	1	ring 12 x 15 x 12
20	2.0399.128.2	1	screw (...) <=
20	2.0399.128.2/10	1	screw m 8 p.1 x 8 => (...)
21	2.2030.002.0	1	ball bearing 12 x 28 x 8
22	2.1219.025.2	1	ring nut m 36 p.1 (...) <=
22	2.1219.025.2/10	1	ring nut m 36 p.1.5 => (...)
23	2.1589.148.0	1	shoulder ring 28.2 x 31.8 x 0.5
23	2.1589.150.0	1	shoulder ring 28.2 x 31.8 x 0.1
23	2.1589.151.0	1	shoulder ring 28.2 x 31.8 x 0.15
24	0.075.1551.3/30	1	support * (...) <=
25	2.1589.146.0	1	shoulder ring 15.2 x 19 x 0.15
25	2.1589.147.0	1	shoulder ring 15.2 x 19 x 0.10
25	2.1589.153.0	1	shoulder ring 15.2 x 19 x 1.00
26	2.1410.057.1	1	circlip 15

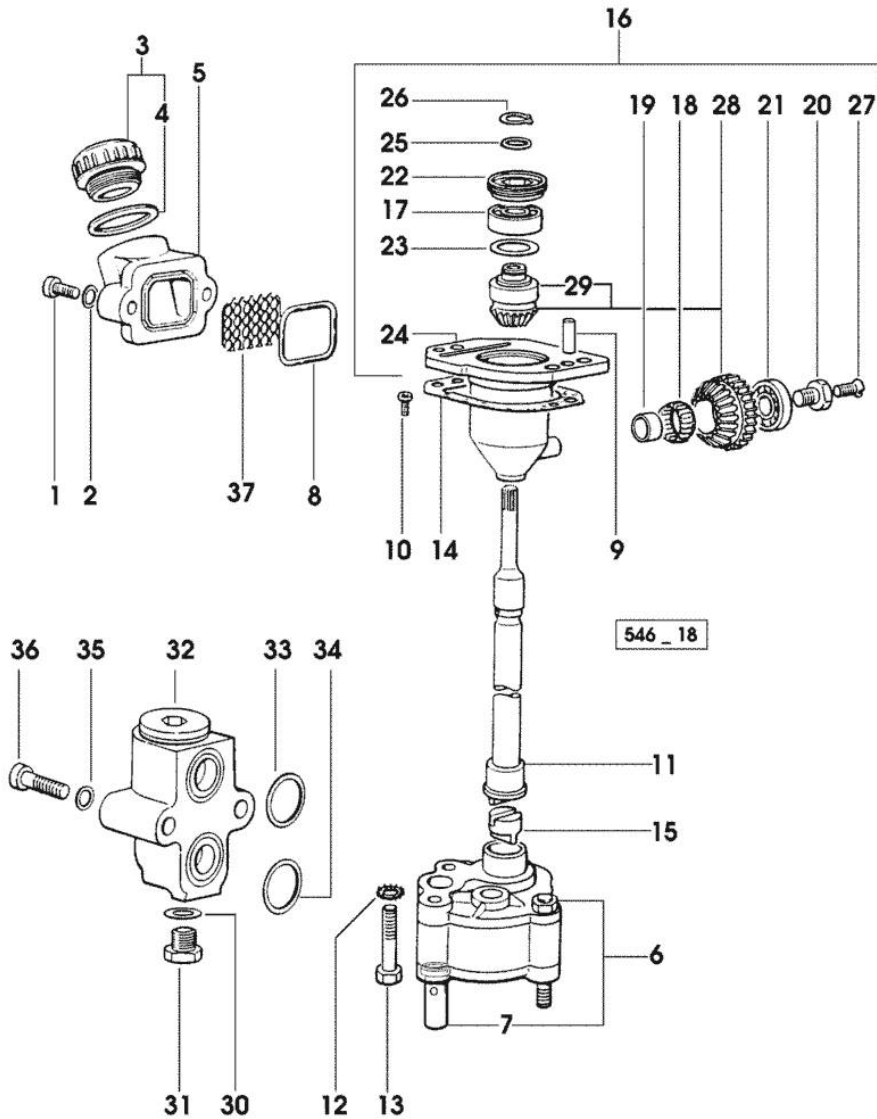



Suggest:

For more complete manuals. Please go to the home page.

<https://www.ebooklibonline.com>

If the above button click is invalid. Please download this document first, and then click the above link to download the complete manual.

Thank you so much for reading

Section: ENGINE
LUBRICATION

Fig.	P/n	QTY	Name
27	2.0342.007.2	1	screw m 4 p.0.7x25
28	0.065.1558.6/10	1	bevel drive
29	0.065.1559.0	1	bush
30	2.1560.010.0	1	gasket 14.2 x 20
31	2.3110.403.1	1	plug m 14 p.1.5x12
32	0.065.1581.4/20	1	valve
33	2.1539.048.0	1	special oil seal 20.35x1.78
34	2.1539.072.0	1	special oil seal 23.52 x 1.78
35	2.1480.014.1	2	washer 8
36	2.0312.215.1	2	screw m 8 p.1.25 x 45
37	0.065.1567.0/10	1	filter

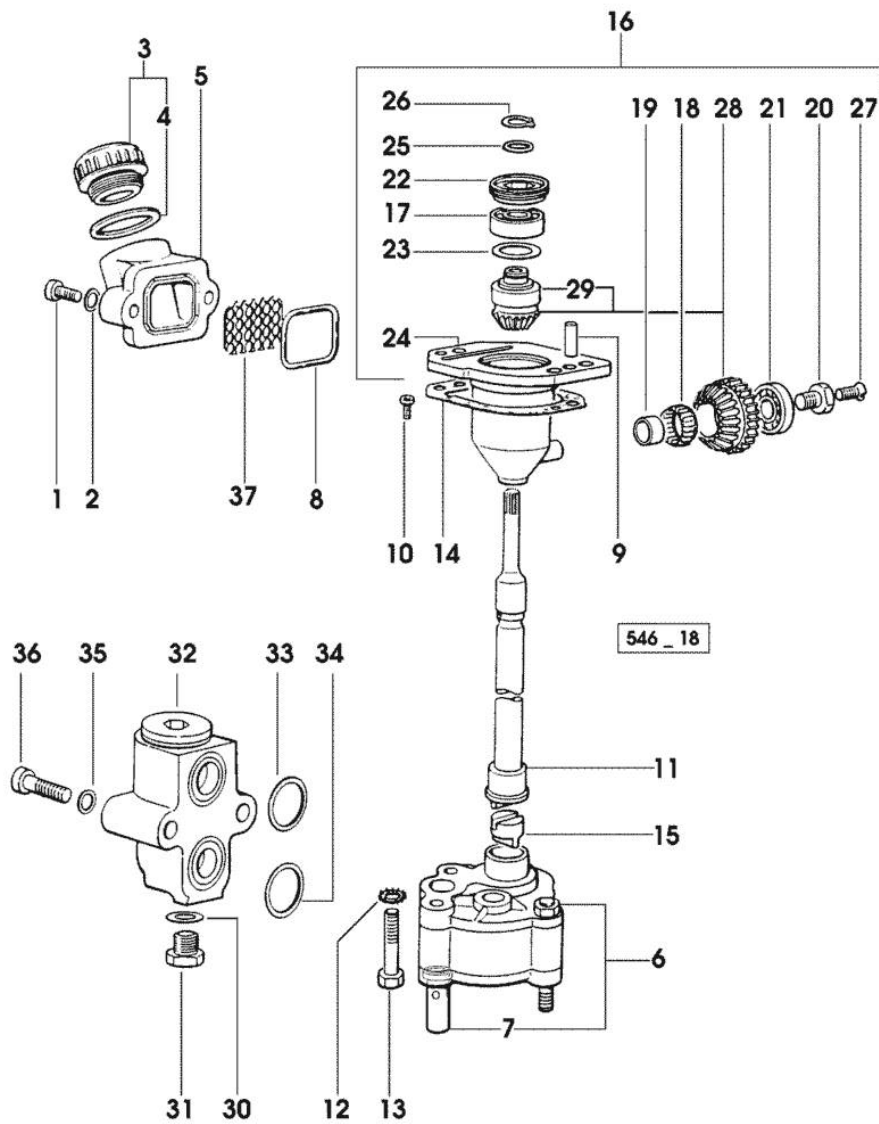

Section: ENGINE
LUBRICATION

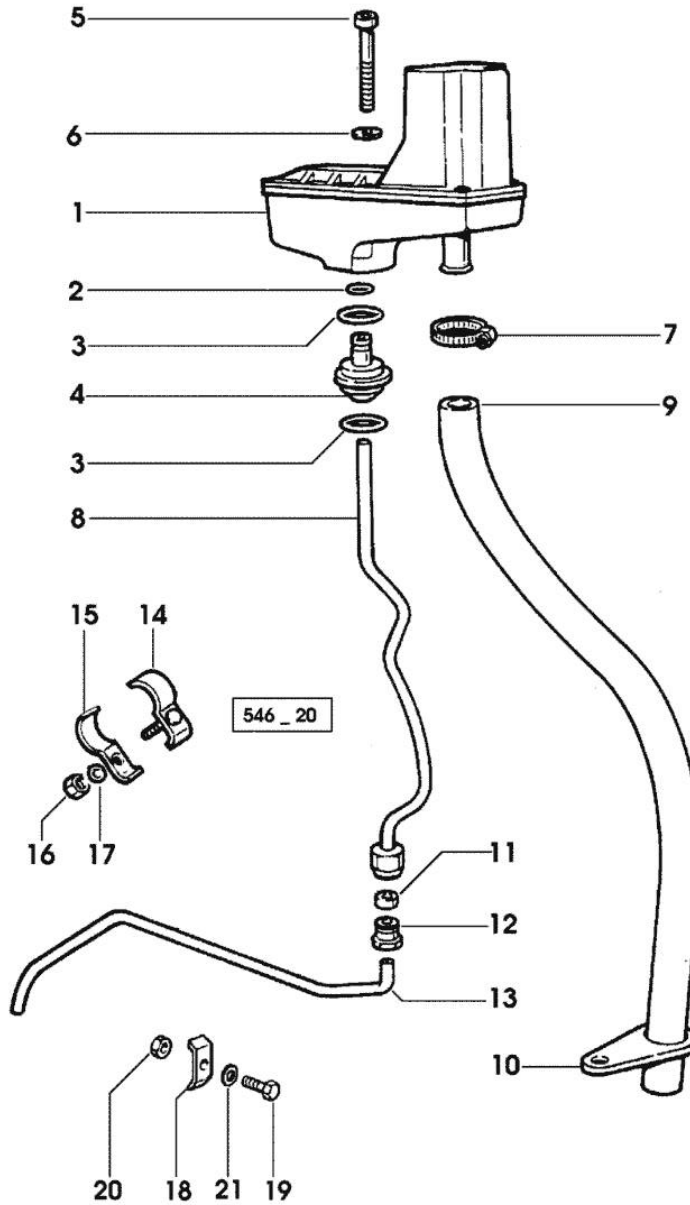

Fig.	P/n	QTY	Name
Notes:			
[EXPLORER II 80]			
1	0.066.1552.4/10	1	sediment bowl ☞ 01.00.65
2	2.1539.074.0	1	special oil seal 7.66 x 1.78
3	2.1539.072.0	2	special oil seal 23.52 x 1.78
4	0.066.1558.0	1	bush
5	2.0312.221.2	2	screw m 8 p.1.25x75
6	2.1480.014.1	2	washer 8
7	2.6859.073.2	1	clamp
8	0.066.1557.2	1	tube
9	0.066.1559.0	1	tube
10	0.075.1151.0	1	bracket
11	2.3350.003.1	1	nosepiece 8
12	2.3339.418.1	1	pipe fitting m 12 p.1
13	0.007.1427.0	1	tube => 13383 X 60HP
13	0.066.1556.0	1	tube - X 70HP - 80HP - 90HP
13	0.069.1550.0	1	tube 13382 <= X 60HP
14	0.075.1552.2	2	bracket - X 70HP - 80HP - 90HP 13382 <= X 60HP
15	0.075.1552.0	2	bracket - X 70HP - 80HP - 90HP 13382 <= X 60HP
16	2.1011.103.2	2	nut m 6 p.1
17	2.1470.002.2	2	lock washer 6
18	0.002.8816.0	1	small plate => 13383 X 60HP
19	2.0112.007.2	1	screw m 6 p.1 x 20
20	2.1011.103.2	1	nut m 6 p.1
21	2.1470.002.2	1	lock washer 6

<https://www.ebooklibonline.com>

Hello dear friend!

Thank you very much for reading.

Enter the link into your browser.

The full manual is available for immediate download.

<https://www.ebooklibonline.com>