

CRANKCASE

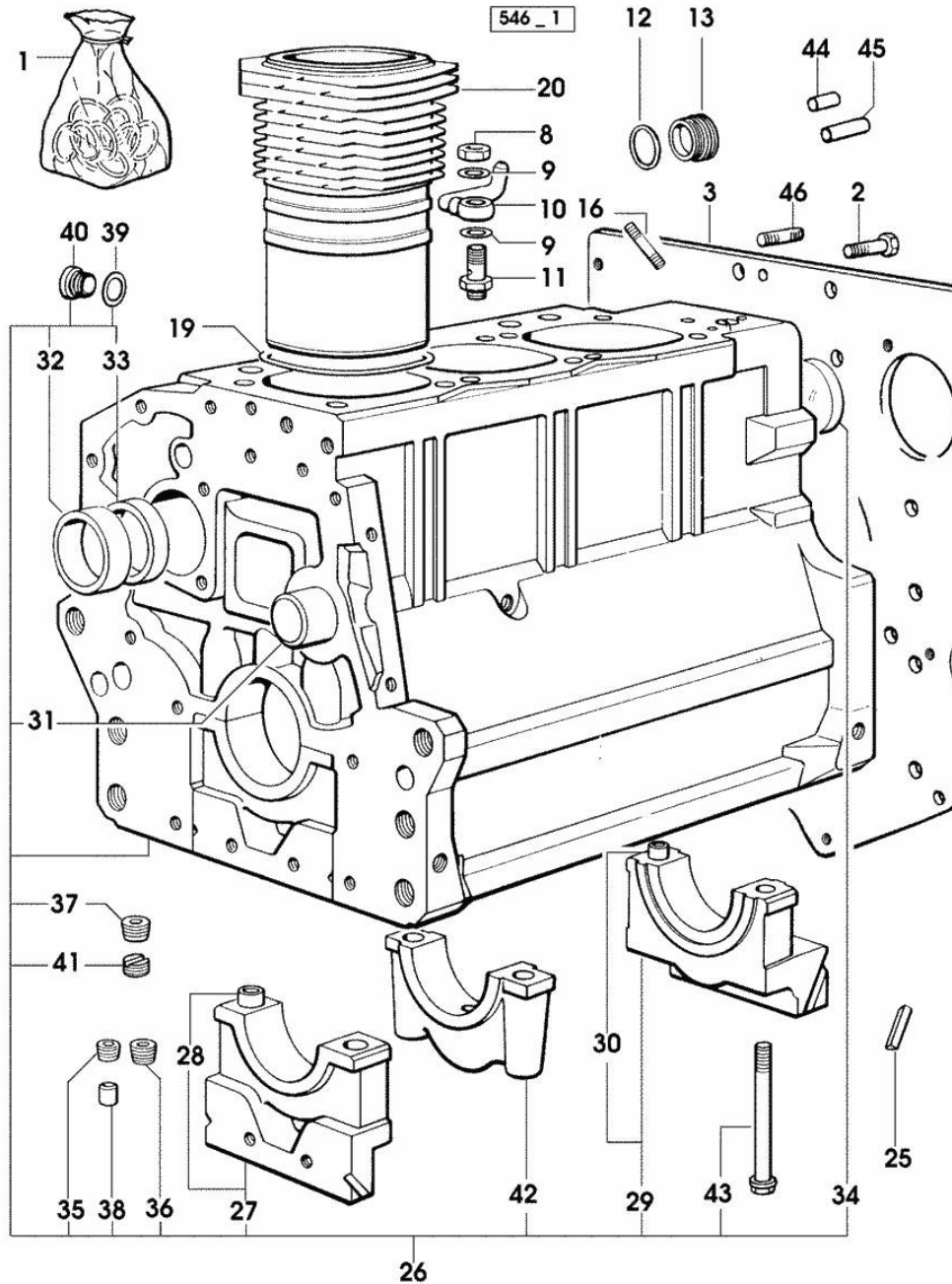

Fig.	P/n	QTY	Name
------	-----	-----	------

Notes:  
[EXPLORER II 60]

1	0.085.0050.6/10		gasket set - FOR ENGINE MOUNTING
2	2.0112.511.2	8	screw m 14 p.2 x 30
3	0.066.1130.0/20	1	flange
8	2.1099.108.2	3	special nut m 10 p.1
9	2.1560.006.0	4	gasket 10.2 x 16
10	0.086.1550.2	3	sprayer nozzle
11	0.065.1160.3/20	3	valve
12	2.1539.047.0	1	special oil seal 26.7x1.78
13	2.3199.405.2	1	plug m 28 p.1.5
16	2.0432.003.7	9	stud bolt m 8 p.1.25 / p.1 x 20
19	2.1519.096.0/20	3	special oil seal 107.67x1.78 12952 <=
19	2.1539.130.0/10	3	special oil seal 117.07x3.53 => 12953
20	0.007.0762.0/50	3	engine cylinder => 12953
20	0.085.1120.0/10	3	engine cylinder 12952 <=
25	0.066.1152.0/10	4	gasket
26	0.007.1150.6/10	1	crankcase => 12593 * 17401 <= - N.1 - 085.1750.2/10 - N.1 - 009.7871.0/20
26	0.085.1110.6	1	crankcase 12592 <=
27	0.065.1112.7	1	support
28	2.1699.165.0	1	bush 12.3x15x16
29	0.065.1116.3	1	support
30	2.1699.165.0	1	bush 12.3x15x16
31	0.066.1151.0	1	pin
32	0.065.1141.0	1	special bushing 59X55X30
33	0.065.1140.0	3	special bushing 59X55X20
34	2.3179.012.0	1	plug 60
35	2.3130.001.1	9	plug 1/8" gas
36	2.3130.002.1	2	plug 1/4" gas
37	2.3130.003.1	7	plug 3/8" gas
38	2.3199.092.0	3	plug 8 x 12
39	2.1560.017.0	1	gasket 22.2 x 27 (...) <=

CRANKCASE

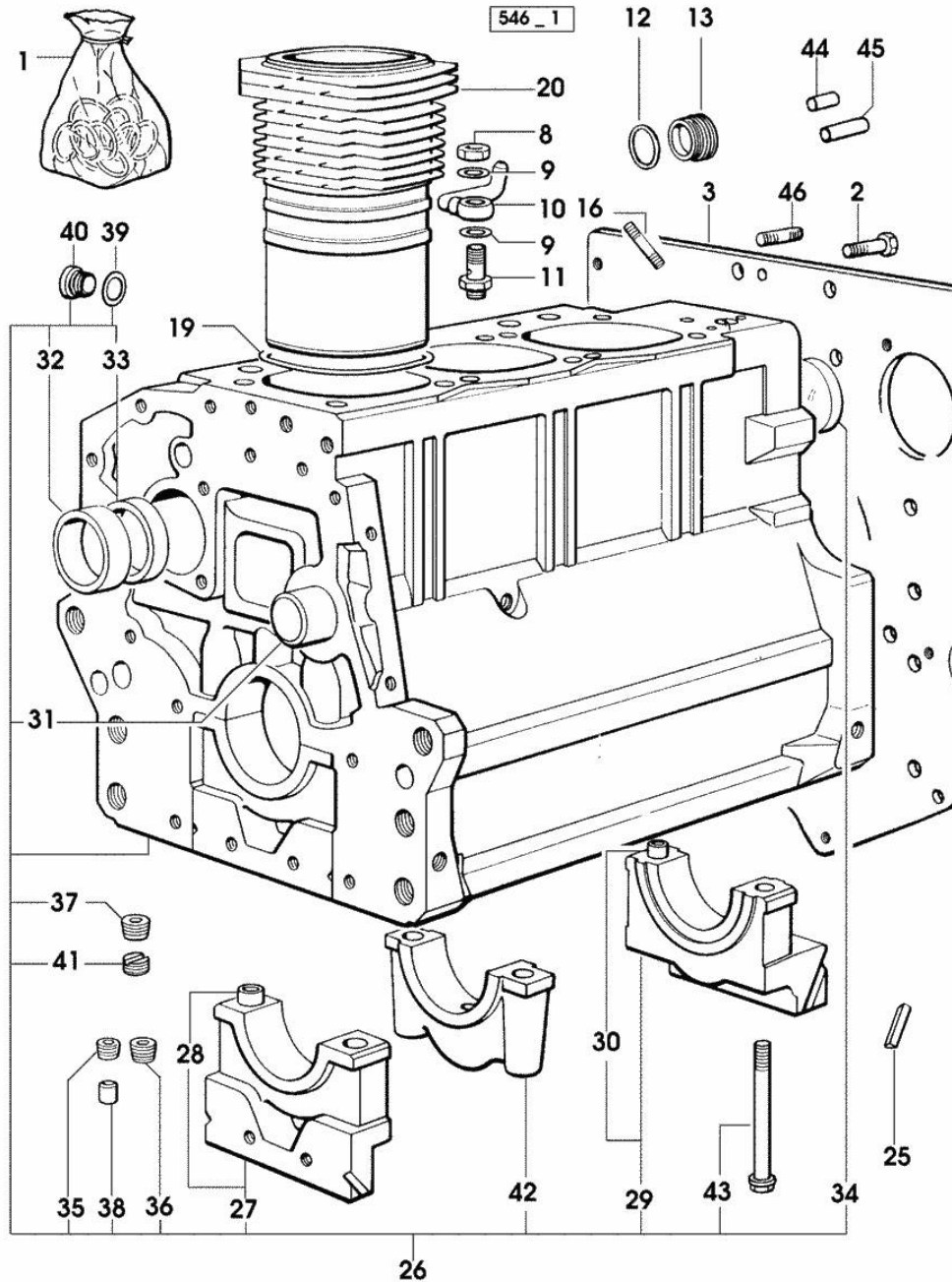

Fig.	P/n	QTY	Name
40	2.3120.002.4	1	plug m 22 x 1.5 (...) <=
41	2.1324.011.0	1	plug
42	0.065.1114.0/10	2	support
43	0.065.1117.0	8	screw m 12 x 100
44	2.1651.912.0	2	cylindrical plug 12x28
45	2.1651.917.0	1	cylindrical plug 12x40
46	2.0432.255.7	2	stud bolt m 12 p.1.75-1.25x25

Section: ENGINE

**TIMING CASE**

Fig.	P/n	QTY	Name
------	-----	-----	------

**Notes:**

[EXPLORER II 60]

1	0.007.1262.3/50	1	guard
2	0.007.1271.0/10	1	small column m 8 p.1.25 / L = mm 60
3	0.007.1272.0/10	2	small column m 8 p.1.25 / L = mm 50
5	2.1310.004.2	3	flat washer 8.4x17
7	2.0112.205.2	3	screw m 8 p.1.25 x 16

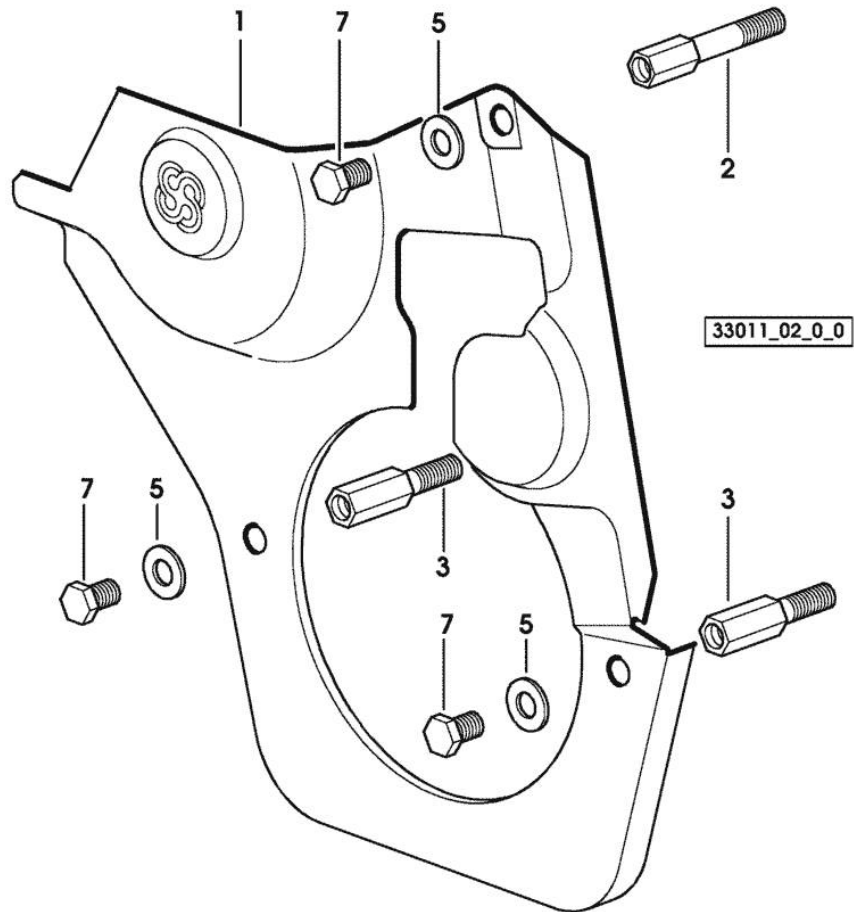

**<https://www.ebooklibonline.com>**

Hello dear friend!

Thank you very much for reading.

Enter the link into your browser.

The full manual is available for immediate download.

**<https://www.ebooklibonline.com>**

Section: ENGINE  
TIMING CASE

Fig.	P/n	QTY	Name
------	-----	-----	------

Notes:  
[EXPLORER II 60]

1	0.065.1132.0/60	1	guard
2	0.065.1150.0/30	1	gasket
3	0.065.1152.0	1	gasket
4	0.065.1151.0	1	cover
5	2.1470.004.2	4	lock washer 8
6	2.0112.205.2	2	screw m 8 p.1.25 x 16
7	2.0432.003.7	2	stud bolt m 8 p.1.25 / p.1 x 20
8	2.1011.405.2	2	nut m 8 p.1
9	2.0312.208.2	8	screw m 8 p.1.25 x 25
10	2.1480.014.1	15	washer 8
11	2.0432.003.7	2	stud bolt m 8 p.1.25 / p.1 x 20
13	2.0312.214.2	3	screw m 8 p.1.25 x 40
14	2.1529.141.0	1	special oil seal
15	2.0312.219.2	4	screw m 8 p.1.25x65

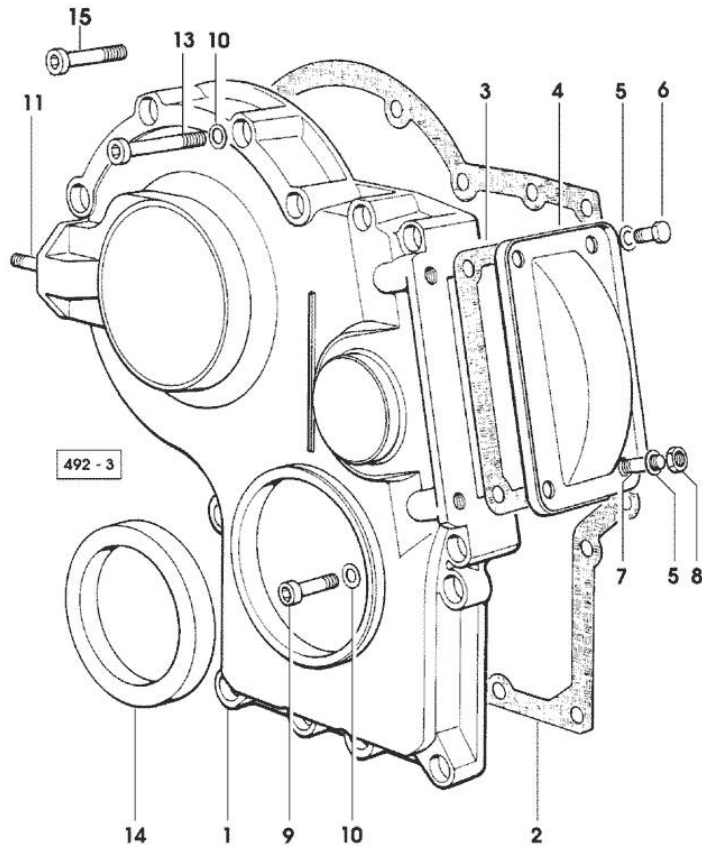

Section: ENGINE

**CRANKSHAFT**

Fig.	P/n	QTY	Name
------	-----	-----	------

**Notes:**

[EXPLORER II 60]

1	0.007.1554.0/20	1	crankshaft * 14257 <= - N.1 - 007.1711.0/10 - N.3 - 2.3130.001.0
4	2.3130.001.1	3	plug 1/8" gas
5	0.078.1220.3/30	3	engine connecting rod
6	2.0399.213.0	6	screw m 12 p.1.25x61.5
7	2.1559.114.0/10	3	special bushing
8	0.069.1247.3/20	1	flywheel
9	0.069.1242.0	1	crown wheel Z = 121
10	2.1720.006.0	2	key 4x6.5
18	0.065.1254.0/20	1	gasket
19	0.007.1711.0/10	1	cover => 14258
19	0.065.1253.0/20	1	cover 14257 <=
20	2.1529.073.0	1	special oil seal 110x130x13
21	2.0112.207.2	9	screw m 8 p 1.25 x 20
22	2.1475.002.2	9	conical washer 8
23	0.065.1225.0	6	con.rod half bushing STANDARD - A = 28.75 -> 29.00
23	0.065.1225.7		con.rod half bushing - mm 0.25
23	0.065.1225.8		con.rod half bushing - mm 0.50
24	0.065.1215.0	4	main half bushing STANDARD
24	0.065.1215.7		main half bushing - mm 0.25
24	0.065.1215.8		main half bushing - mm 0.50
25	0.065.1216.0	4	main half bushing
25	0.065.1216.7		main half bushing - mm 0.25
25	0.065.1216.8		main half bushing - mm 0.50
26	0.065.1218.0	3	shim STANDARD
26	0.065.1218.7		shim + mm 0.10
26	0.065.1218.8		shim + mm 0.15
27	0.086.0060.6/30	3	complete piston
28	0.086.0052.6/10	3	piston ring set
29	0.078.1236.0	3	piston pin Ø 18 / Ø 35 / L = mm 86
30	2.1411.014.1	6	circlip 35
31	2.0139.022.2	6	screw m 12 p.1.25x55
32	0.255.2525.0/10	1	flange
34	2.1652.915.0	1	cylindrical plug 12x35

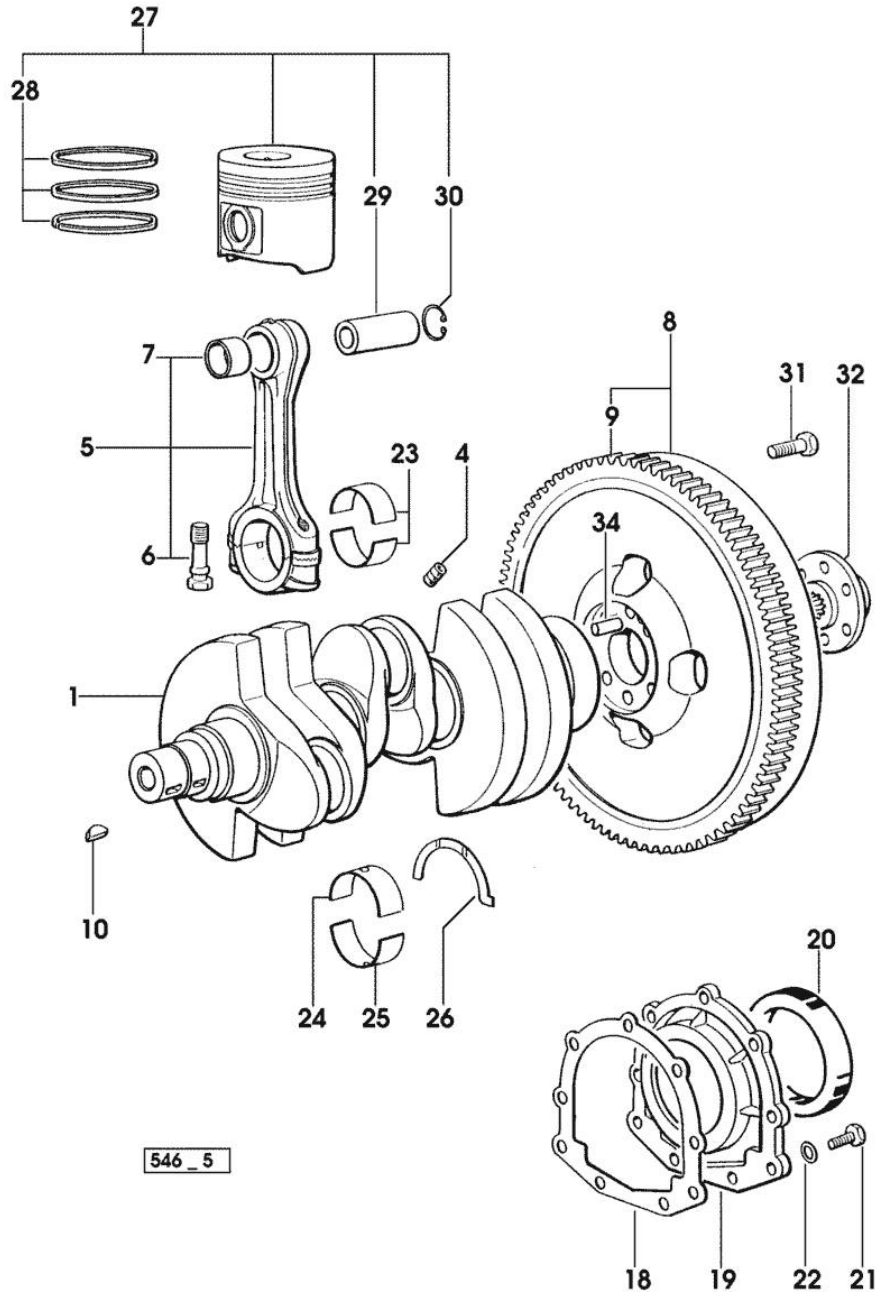

Section: ENGINE

ENGINE SHAFT - PULLEYS

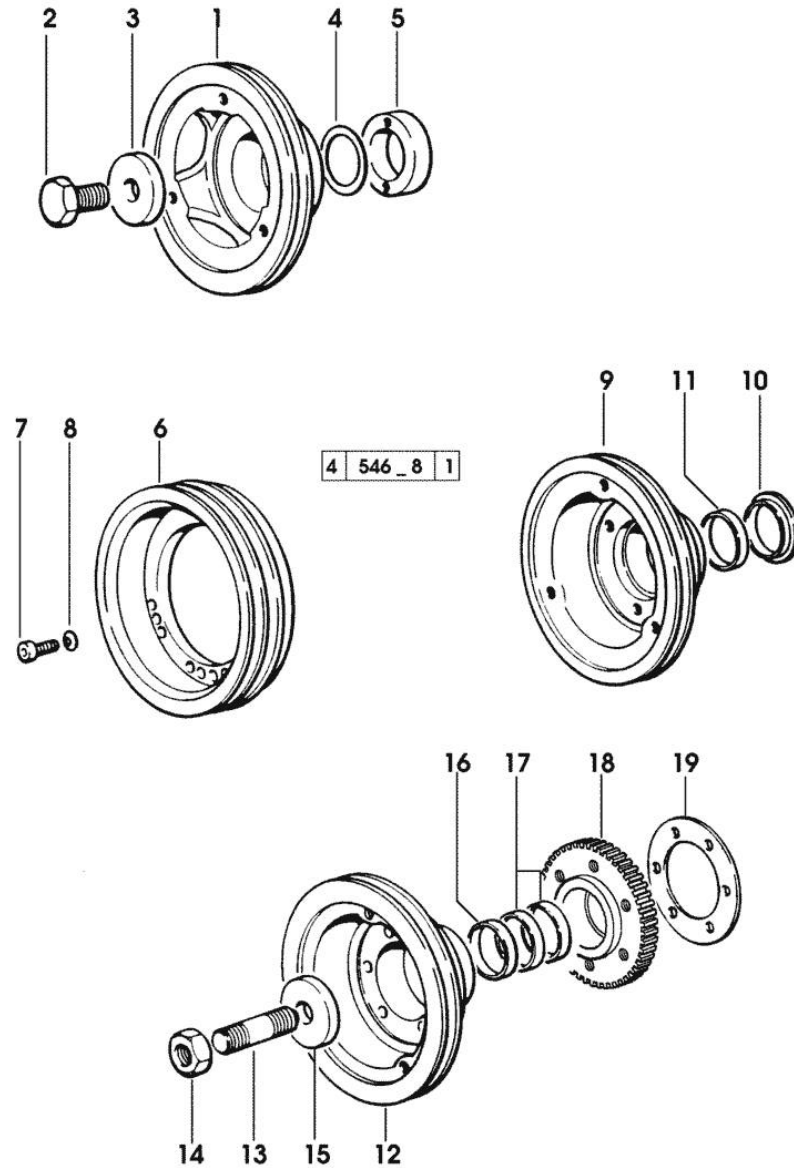

Fig.	P/n	QTY	Name
<b>Notes:</b>			
[EXPLORER II 60]			
1	0.007.1330.0/30	1	pulley
2	2.0399.144.7/10	1	screw m 20 p.1.5x51 * (...) <=
			- N.1 - 2.1599.524.7
3	2.1599.524.7	1	washer 21x60x12 * (...) <=
			- N.1 - 2.0399.144.7
4	2.1589.189.0	3	shoulder ring mm 1.00
5	0.085.1248.0/10	1	hub
6	0.086.1251.0	1	pulley - FOR ACCESSORIES
7	2.0312.308.1	3	screw m 10 p.1.5 x 25
8	2.1480.015.1	3	washer 10
9	0.085.1253.0/10	1	pulley (...) <=
			- FOR P.T.O. FRONT
10	0.085.1254.0	1	ring
11	0.065.1256.0	1	ring 45x52
12	0.086.1244.0	1	pulley => (...)
			- FOR P.T.O. FRONT
13	2.0439.195.7	1	stud bolt m 20 p.1.5x80
14	2.1019.094.7	1	nut m 20 p.1.5
15	2.1599.524.7	1	washer 21x60x12
16	2.1579.865.0	1	spacer 45.2x51.8x10
17	0.065.1256.0	2	ring 45x52
18	0.011.3515.0/10	1	hub Z = 48
19	2.1589.136.0	3	shoulder ring 71x110x0.5
			2.1589.137.0
			1
			shoulder ring 71x110x1

Section: ENGINE

**CAMSHAFT**

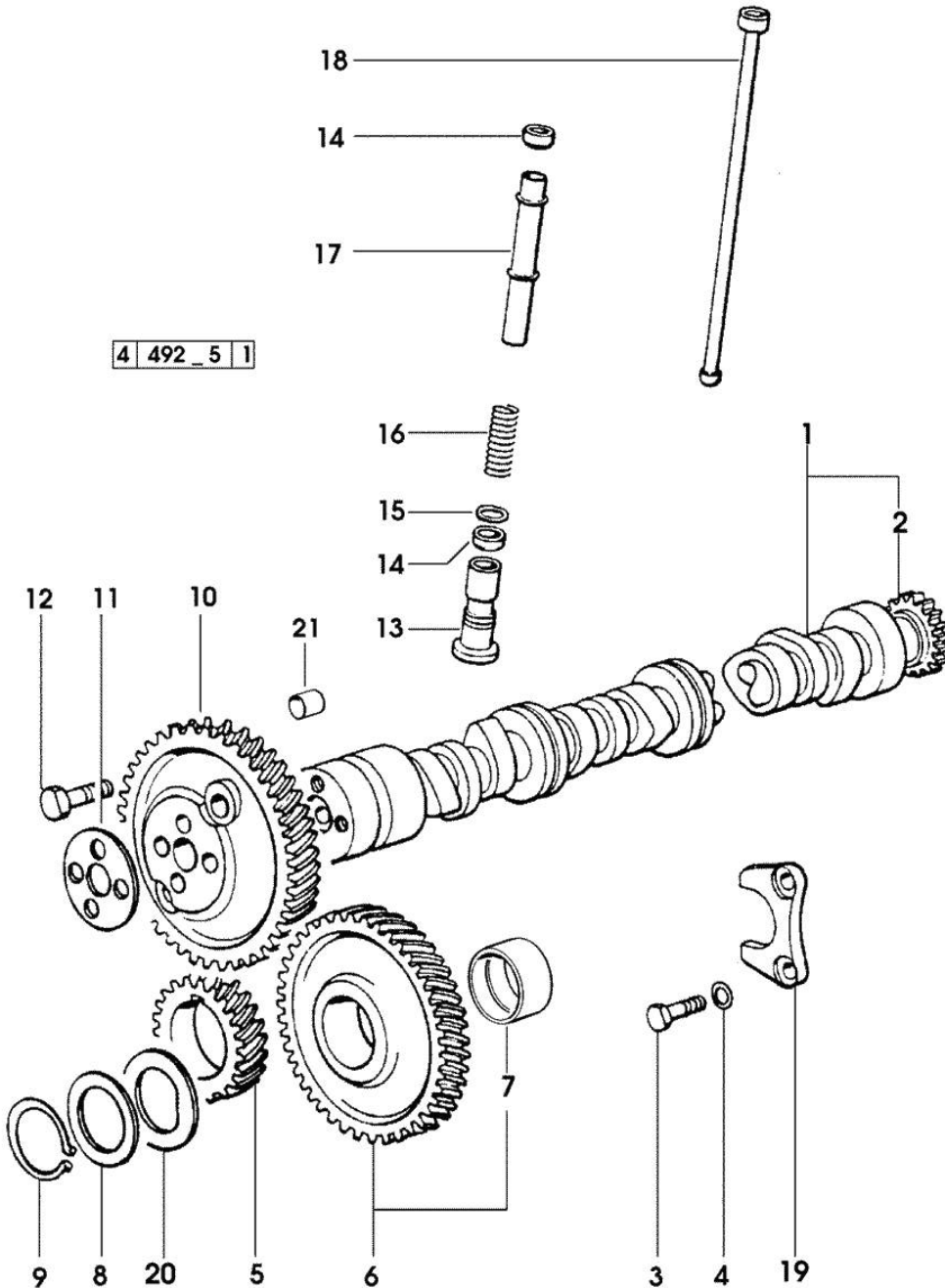

Fig.	P/n	QTY	Name
------	-----	-----	------

Notes:  
[EXPLORER II 60]

1	0.070.1310.3/40	1	camshaft
2	0.065.1324.0/10	1	gear Z = 32
3	2.0312.206.2	2	screw m 8 p 1.25 x 20
4	2.1480.014.1	2	washer 8
5	0.065.1323.0/30	1	gear Z = 29
6	0.007.1177.3/10	1	gear z = 57
			- WITH RED IDENTIFICATION STAMP
6	0.007.1178.3/10	1	gear z = 57
			- WITH YELLOW IDENTIFICATION STAMP
6	0.007.1179.3/10	1	gear z = 57
			- WITH GREEN IDENTIFICATION STAMP
7	2.1559.185.0/10	1	bushing
8	0.065.1352.0	1	shim
9	2.1410.016.1	1	circlip 40
10	0.065.1354.0/20	1	gear z=58
11	0.065.1350.0	1	small disc
12	2.0132.207.2	4	screw m 10 p.1 x 25
13	0.065.1330.0	6	tappets
14	2.1569.114.0/10	12	gasket 14x18.5x8
15	2.1599.437.0	6	shoulder ring
16	2.4019.300.1/10	6	spring 18.5x52x2
17	0.065.1332.0	6	sleeve
18	0.065.1331.2	6	rod
19	0.065.1353.0	1	small plate
20	0.065.1351.0	2	shoulder ring
21	2.1559.398.0	1	bushing 10.5x13x12

Section: ENGINE

## CYLINDER HEAD

Fig.	P/n	QTY	Name
------	-----	-----	------

## Notes:

[EXPLORER II 60]

1	2.0399.130.2	3	screw m 8 x 30 17846 <=
1	2.0399.130.2/10	3	screw m 8x36x44 => 17847
2	2.1569.170.0/10	3	gasket 8.2 x 14
3	0.007.1139.0/10	3	small cap * 17847 <=
			- N.1 - 2.0399.130.2/10
4	0.069.1450.0/30	1	tappet gasket
5	2.1011.321.2	6	nut m 10 p.1.25
6	2.0432.163.7	6	stud bolt m 10 p.1.5 / p.1.25 x 45
7	0.066.1430.0/10	3	support
8	0.066.1432.3	6	rocker arm
9	2.1559.021.0/40	6	bushing 15x19x22
10	2.1410.055.1	6	circlip 19
11	2.1011.405.2	6	nut m 8 p.1
12	0.021.1434.0	6	screw
13	0.074.1423.0	6	conical valve cotter
14	0.066.1425.0	6	cup
15	2.4019.287.0	6	spring
16	0.065.1413.0/10	3	bush L = mm 97.1 12225 <=
17	2.0432.161.7	3	stud bolt m 10 p.1.5 / p.1.25 x 40
18	0.065.1443.0/20	12	screw
20	2.0432.007.2	6	stud bolt m 8 p.1.25 / p.1 x 30
21	0.085.1450.0		head gasket mm 0.5 -A-
21	0.085.1451.0		head gasket mm 0.7 -B-
21	0.085.1452.0		head gasket mm 1.0 -C-
21	0.085.1453.0		head gasket mm 0.8 -D-
22	0.066.1421.0	3	exhaust valve
23	0.010.6016.0	3	inlet valve mm 43.63 / Ø mm 9
24	0.007.1110.3/50	3	engine head * 12225 <=
			- N.1 - 007.1122.0/10
25	0.066.1427.0	3	valve seat
26	0.078.1426.0	3	valve seat
27	0.007.1779.0/10	6	valve guide
28	0.066.1431.0	3	pin
29	2.1599.432.0	6	shoulder ring
30	0.085.0057.6/10		gasket set

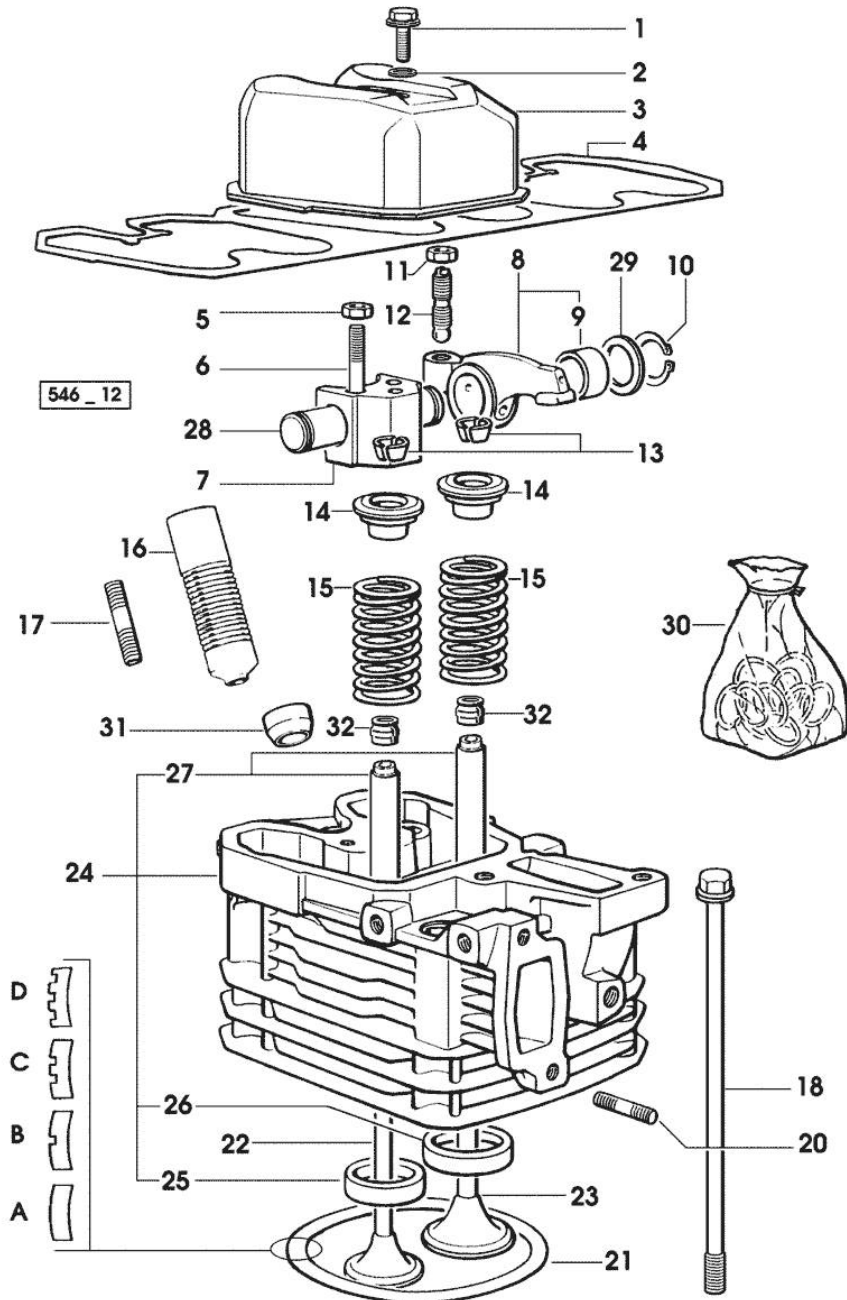

Section: ENGINE  
CYLINDER HEAD

Fig.	P/n	QTY	Name
------	-----	-----	------

- FOR 1 CYLINDER VALVE GRINDING AND PISTON RINGS REPLACEMENT

31 0.007.1122.0/10 3 bush L = mm 6.4

=> 12226

32 2.1519.117.0 6 special oil seal

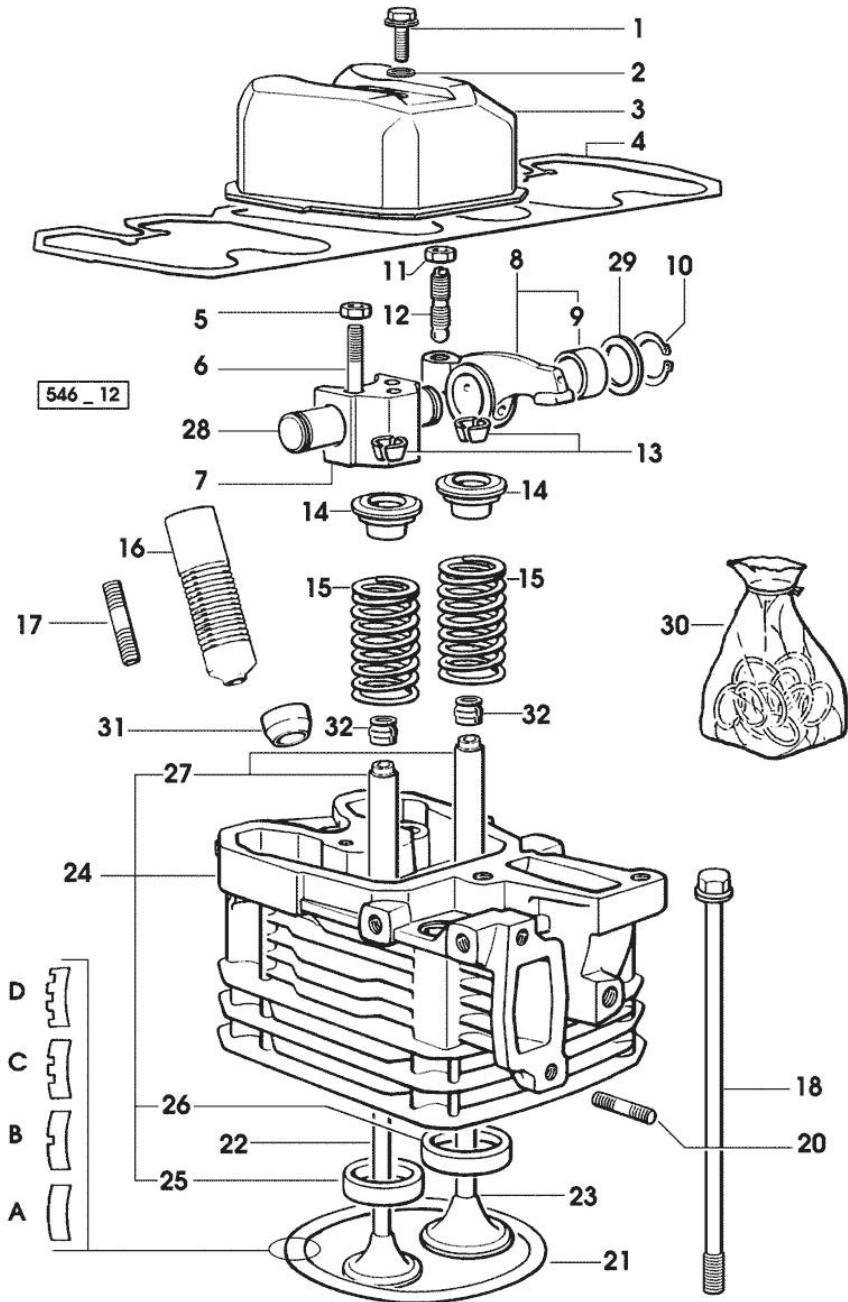

Section: ENGINE  
LUBRICATION

Fig.	P/n	QTY	Name
------	-----	-----	------

Notes:  
[EXPLORER II 60]

1	0.007.1425.3	1	tube => 13383
1	0.070.1531.3	1	tube 13382 <=
2	2.0112.205.2	1	screw m 8 p.1.25 x 16
3	2.1011.105.2	1	nut m 8 p.1.25
4	2.1470.004.2	2	lock washer 8
5	0.065.1538.0	1	flange
6	2.1539.040.0	1	special oil seal 21.82 x 3.53
7	2.0312.216.2	2	screw m 8 p.1.25x50
8	2.1310.004.2	2	flat washer 8.4x17
9	0.007.7319.3	1	oil cooler
10	2.1539.048.0	2	special oil seal 20.35x1.78
11	0.085.1513.2/20	1	dipstick
12	2.1539.065.0	2	special oil seal 8.73 x 1.78
13	2.3249.014.2	1	pipe fitting m 12 p.1.5
14	2.1560.008.0	2	gasket 12.2 x 18
15	0.044.1567.0	1	oil filter element
16	2.3339.307.0	1	pipe fitting m 22 p.1.5-3/4"
17	2.0399.125.2/10	2	screw m 8 x 55
18	2.3339.448.2	1	pipe union m 12 p.1.75

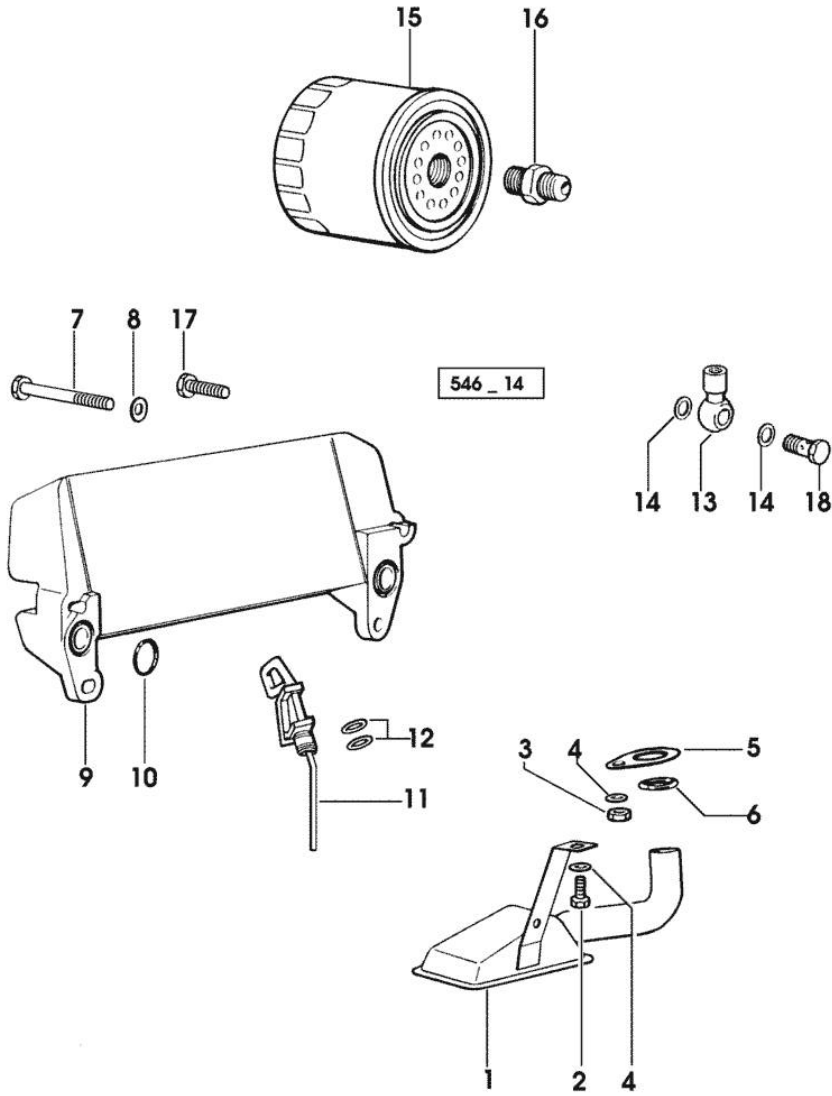

Section: ENGINE  
LUBRICATION

Fig.	P/n	QTY	Name
------	-----	-----	------

Notes:  
[EXPLORER II 60]

1	0.070.1510.2/60	1	oil sump
2	0.070.1551.0	1	gasket 7479 <=
3	2.3199.001.2	1	plug 1/2" gas
4	2.1560.054.0	1	gasket 21 x 26
5	2.0432.003.7	22	stud bolt m 8 p.1.25 / p.1 x 20 7479 <=
6	2.1121.105.2	22	nut m 8 x 1 7479 <=
7	2.1470.004.2	22	lock washer 8 7479 <=
8	2.1599.459.0	3	small plate 7479 <=
9	2.0112.205.2	22	screw m 8 p.1.25 x 16 => 7480
10	2.1475.002.7	22	washer 8.4 => 7480

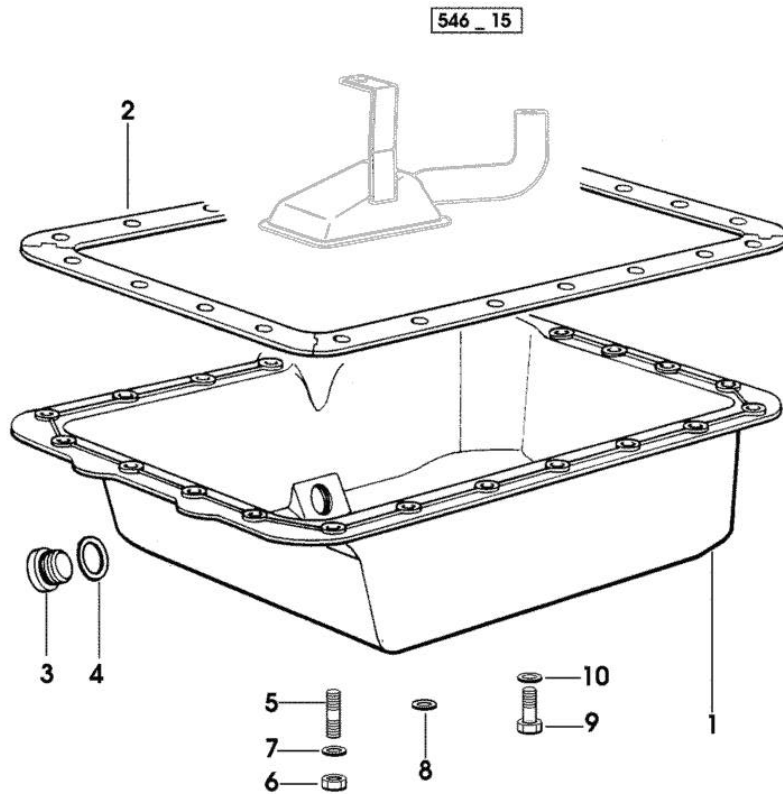

Section: ENGINE  
LUBRICATION

Fig.	P/n	QTY	Name
------	-----	-----	------

Notes:  
[EXPLORER II 60]

1	0.007.0614.0/10	1	gasket
2	0.007.1422.0/40	1	oil sump * 13382 <= - N.1 - 007.1427.0 - 002.8816.0 - 2.0112.007.2 - 2.1011.103.2 - 2.1470.002.2
3	2.1560.054.0	1	gasket 21 x 26
4	2.3199.001.2	1	plug 1/2" gas
5	2.1470.004.2	22	lock washer 8
6	2.0112.226.2	7	screw m 8 p.1.25 x 85 => 13383
6	2.0112.235.2	3	screw m 8 p.1.25 x 130 13382 <=
6	2.0122.227.2	4	screw m 8 p.1x90 13382 <=
8	2.0112.215.2	13	screw m 8 p.1.25 x 40
9	2.0112.411.2	4	screw m 12 p.1.75 x 30
10	2.1470.007.2	4	lock washer 12
11	2.0112.239.2	2	screw m 8 p.1.25 x 150
12	2.0112.720.1	4	screw m 18 p.2.5 x 55
13	2.1475.007.7	4	washer 18
14	0.008.8586.0/10	4	shim mm 0.20
15	0.008.8587.0/10	8	shim mm 0.50
16	2.0112.235.2	3	screw m 8 p.1.25 x 130

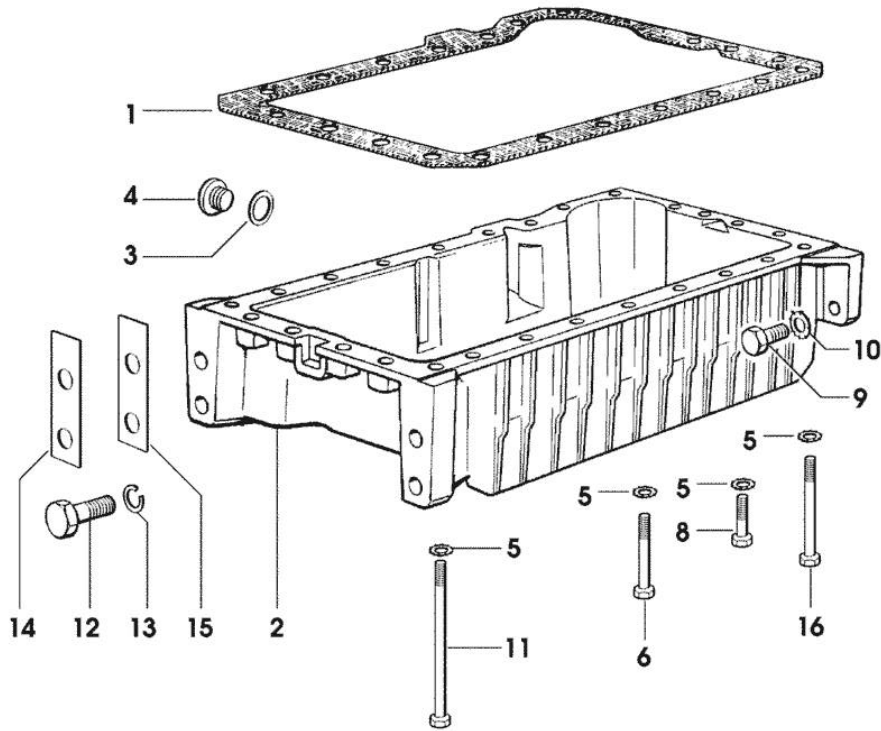

546\_16

Section: ENGINE  
LUBRICATION

Fig.	P/n	QTY	Name
------	-----	-----	------

Notes:  
[EXPLORER II 60]

1	2.0312.206.2	2	screw m 8 p 1.25 x 20
2	2.1480.014.1	2	washer 8
3	0.041.1135.4	1	plug 1" gas
4	2.1569.072.0	1	gasket 32 x 39.5 x 2
5	0.065.1565.0/10	1	pipe union
6	0.010.5441.4/10	1	oil pump - X 70HP - 80HP - 90HP
6	0.010.5481.4	1	oil pump - X 60HP
7	0.065.1552.3/60	1	valve
8	2.1539.042.0	1	special oil seal 47.35x1.78
9	2.1651.711.0	2	pin 8 x 14
10	2.0169.005.2	2	screw m 6 p.1 x 12
11	0.065.1569.0/40	1	shaft
12	2.1470.006.2	2	lock washer 10
13	2.0112.325.2	2	screw m 10 p.1.5 x 80
14	0.065.1560.0/20	2	gasket
15	0.065.1562.0/10	1	joint
16	0.075.1551.4/20	1	support
17	2.2020.001.0	1	ball bearing 15 x 32 x 8.00
18	2.2725.016.0	1	roller cage 15 x 21 x 12
19	2.2680.020.0	1	ring 12 x 15 x 12
20	2.0399.128.2	1	screw (...) <=
20	2.0399.128.2/10	1	screw m 8 p.1 x 8 => (...)
21	2.2030.002.0	1	ball bearing 12 x 28 x 8
22	2.1219.025.2	1	ring nut m 36 p.1 (...) <=
22	2.1219.025.2/10	1	ring nut m 36 p.1.5 => (...)
23	2.1589.148.0	1	shoulder ring 28.2 x 31.8 x 0.5
23	2.1589.150.0		shoulder ring 28.2 x 31.8 x 0.1
23	2.1589.151.0		shoulder ring 28.2 x 31.8 x 0.15
24	0.075.1551.3/30	1	support * (...) <=
			- N.1 - 2.1519.025.2/10 - 2.0399.128.2/10
25	2.1589.146.0		shoulder ring 15.2 x 19 x 0.15
25	2.1589.147.0		shoulder ring 15.2 x 19 x 0.10
25	2.1589.153.0	1	shoulder ring 15.2 x 19 x 1.00
26	2.1410.057.1	1	circlip 15

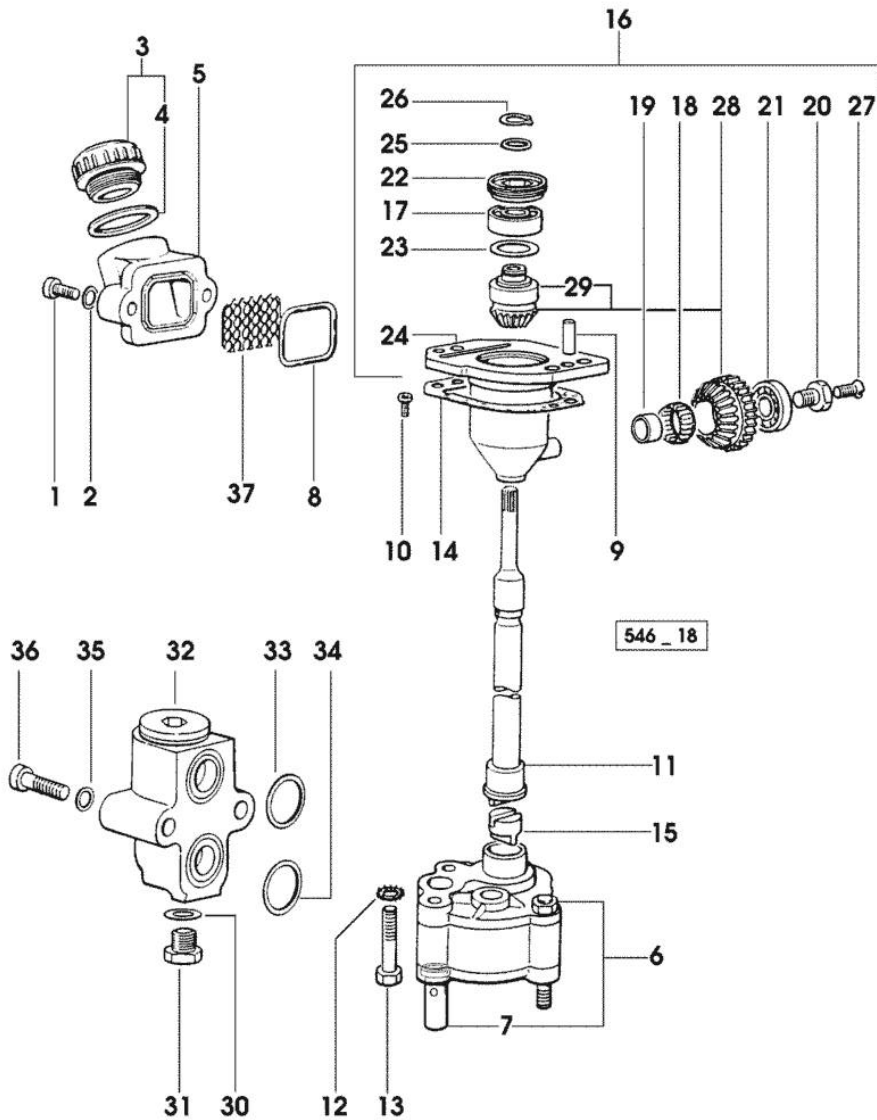



**Suggest:**

**For more complete manuals. Please go to the home page.**

**<https://www.ebooklibonline.com>**

**If the above button click is invalid. Please download this document first, and then click the above link to download the complete manual.**

**Thank you so much for reading**

Section: ENGINE  
LUBRICATION

Fig.	P/n	QTY	Name
27	2.0342.007.2	1	screw m 4 p.0.7x25
28	0.065.1558.6/10	1	bevel drive
29	0.065.1559.0	1	bush
30	2.1560.010.0	1	gasket 14.2 x 20
31	2.3110.403.1	1	plug m 14 p.1.5x12
32	0.065.1581.4/20	1	valve
33	2.1539.048.0	1	special oil seal 20.35x1.78
34	2.1539.072.0	1	special oil seal 23.52 x 1.78
35	2.1480.014.1	2	washer 8
36	2.0312.215.1	2	screw m 8 p.1.25 x 45
37	0.065.1567.0/10	1	filter

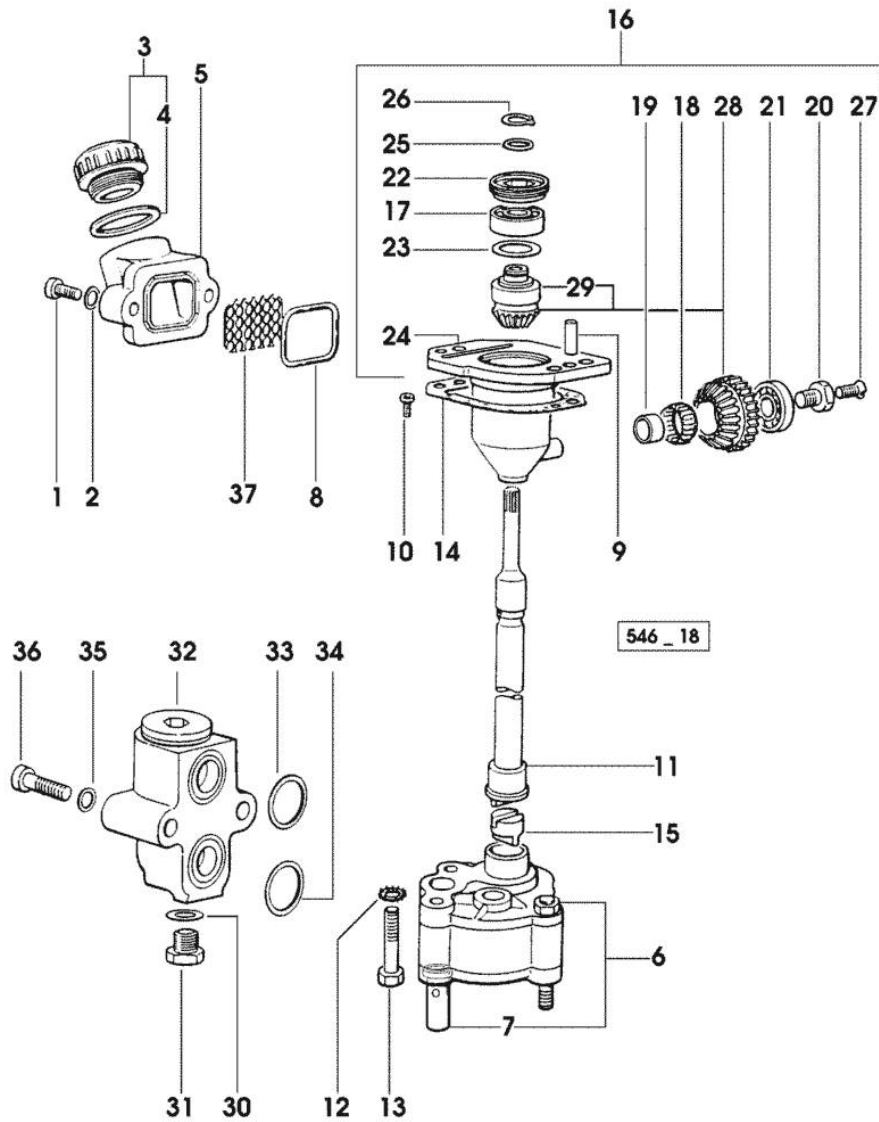

Section: ENGINE  
LUBRICATION

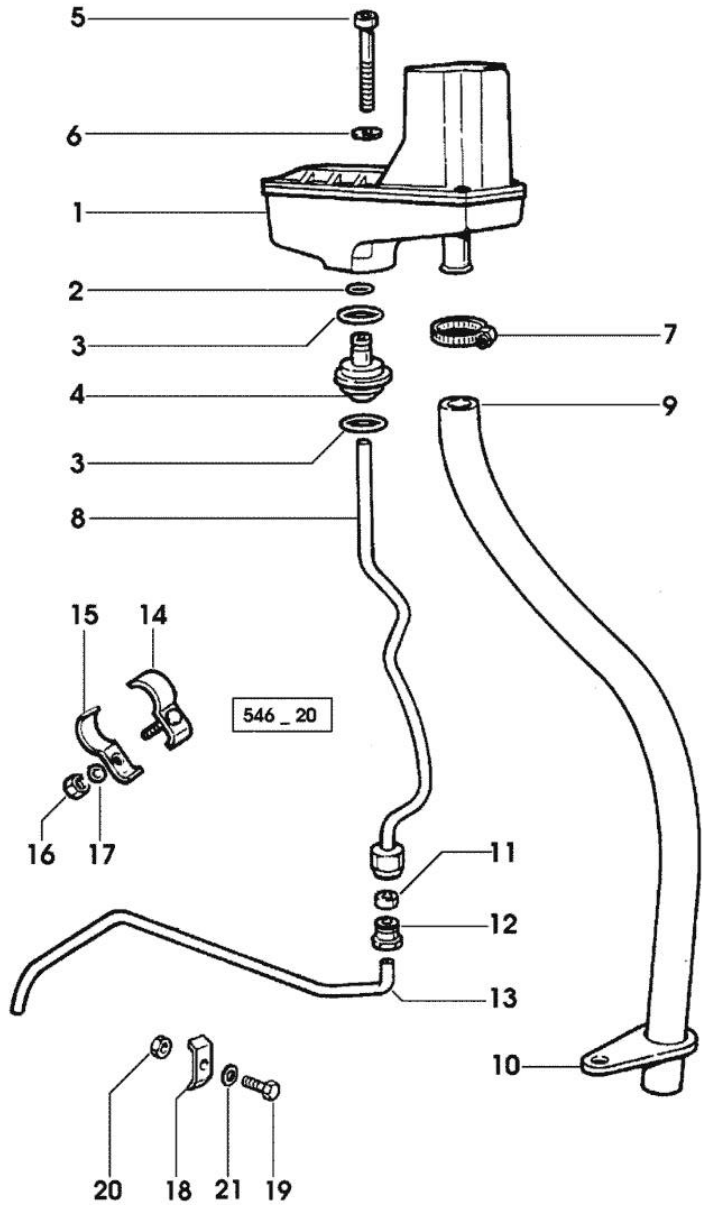

Fig.	P/n	QTY	Name
------	-----	-----	------

Notes:  
[EXPLORER II 60]

1	0.066.1552.4/10	1	sediment bowl ☞ 01.00.65
2	2.1539.074.0	1	special oil seal 7.66 x 1.78
3	2.1539.072.0	2	special oil seal 23.52 x 1.78
4	0.066.1558.0	1	bush
5	2.0312.221.2	2	screw m 8 p.1.25x75
6	2.1480.014.1	2	washer 8
7	2.6859.073.2	1	clamp
8	0.066.1557.2	1	tube
9	0.066.1559.0	1	tube
10	0.075.1151.0	1	bracket
11	2.3350.003.1	1	nosepiece 8
12	2.3339.418.1	1	pipe fitting m 12 p.1
13	0.007.1427.0	1	tube => 13383 X 60HP
13	0.066.1556.0	1	tube - X 70HP - 80HP - 90HP
13	0.069.1550.0	1	tube 13382 <= X 60HP
14	0.075.1552.2	2	bracket - X 70HP - 80HP - 90HP 13382 <= X 60HP
15	0.075.1552.0	2	bracket - X 70HP - 80HP - 90HP 13382 <= X 60HP
16	2.1011.103.2	2	nut m 6 p.1
17	2.1470.002.2	2	lock washer 6
18	0.002.8816.0	1	small plate => 13383 X 60HP
19	2.0112.007.2	1	screw m 6 p.1 x 20
20	2.1011.103.2	1	nut m 6 p.1
21	2.1470.002.2	1	lock washer 6

**<https://www.ebooklibonline.com>**

Hello dear friend!

Thank you very much for reading.

Enter the link into your browser.

The full manual is available for immediate download.

**<https://www.ebooklibonline.com>**