

CRANKCASE

Fig.	P/n	QTY	Name
------	-----	-----	------

Notes:

[EXPLORER 90.4 -> ZKDCF80200TS20001]

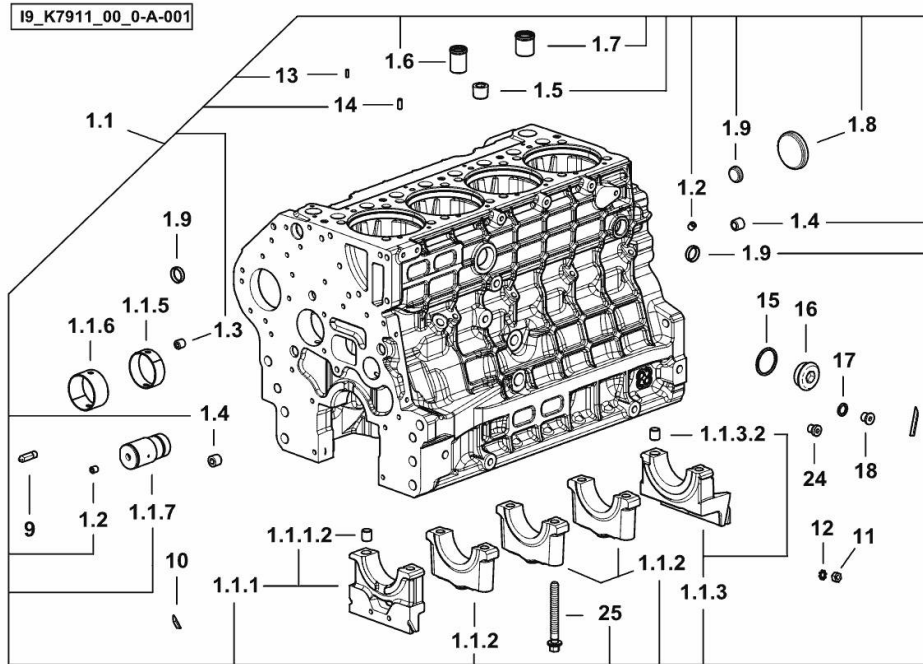

1.1	0.020.4332.3/20	1	crankcase
1.1.1	0.019.5106.3	1	support
1.1.1.2	2.1699.165.0	1	bush 12.3x15x16
1.1.2	0.019.5107.7	3	support
1.1.3	0.019.5108.3	1	support
1.1.3.2	2.1699.165.0	1	bush 12.3x15x16
1.1.5	0.065.1140.0	4	special bushing 59X55X20
1.1.6	0.065.1141.0	1	special bushing 59X55X30
1.1.7	0.019.4412.0	1	pin
1.2	2.3130.001.7	15	plug
1.3	2.3130.002.7	2	plug 1/4" gas
1.4	2.3130.003.7	4	plug 3/8" gas
1.5	2.3130.005.7	3	plug
1.6	0.019.4146.0	1	tube
1.7	0.019.6173.0	1	tube
1.8	2.3179.012.0	1	plug 60
1.9	2.3171.010.4	5	plug 25
9	0.019.4415.0/10	1	tube
10	0.066.1152.0/10	4	gasket
11	2.1011.405.2	2	nut m 8 p.1
12	2.1470.004.2	4	lock washer 8
13	2.1651.305.0	4	pin 4 x 12
14	2.1651.507.0	4	pin 6 x 16
15	2.1560.027.0	1	copper gasket 38.3x44
16	2.3139.031.2	1	plug
17	2.1560.010.0	1	gasket 14.2 x 20
18	2.3199.292.0	1	plug 1/4" gas
24	2.3139.024.2	1	plug m 12 p.1.5 (-> 20001)
25	2.0399.367.7	10	screw

CYLINDER LINER O-RING

Fig.	P/n	QTY	Name
------	-----	-----	------

Notes:

[EXPLORER 90.4 -> ZKDCF80200TS20001]

16	2.1539.259.0	8	special oil seal 107.62x2.62
----	--------------	---	------------------------------

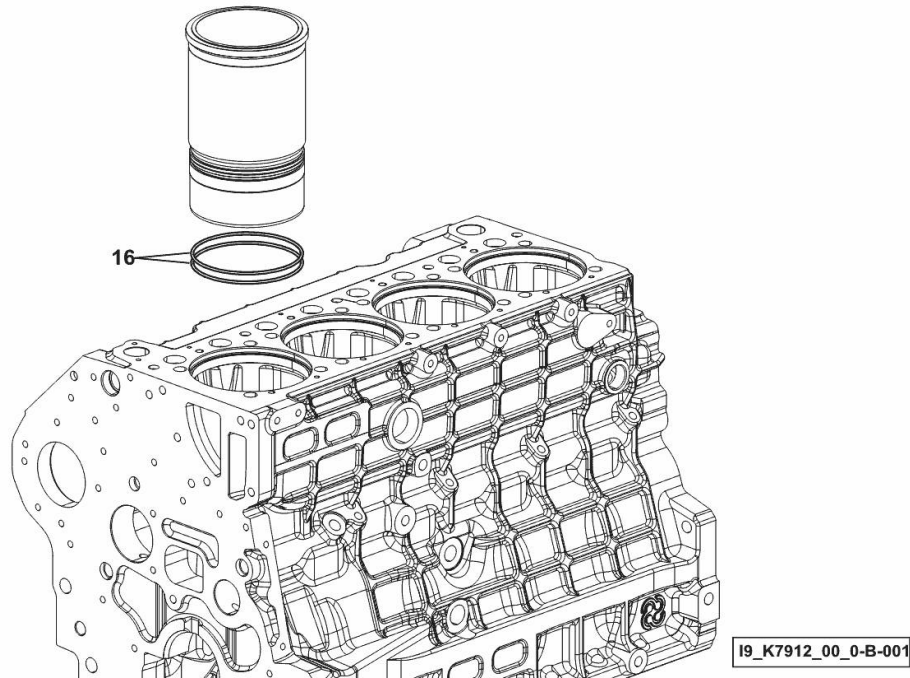

SIDE PLUG FOR CYLINDER BLOCK

Fig.	P/n	QTY	Name
------	-----	-----	------

Notes:

- FOR TYPES WITH TRAILER AIR BRAKING [EXPLORER 90.4 -> ZKDCF80200TS20001]

12	2.1560.018.0	1	gasket 22.2 x 29
13	2.3120.102.0	1	plug

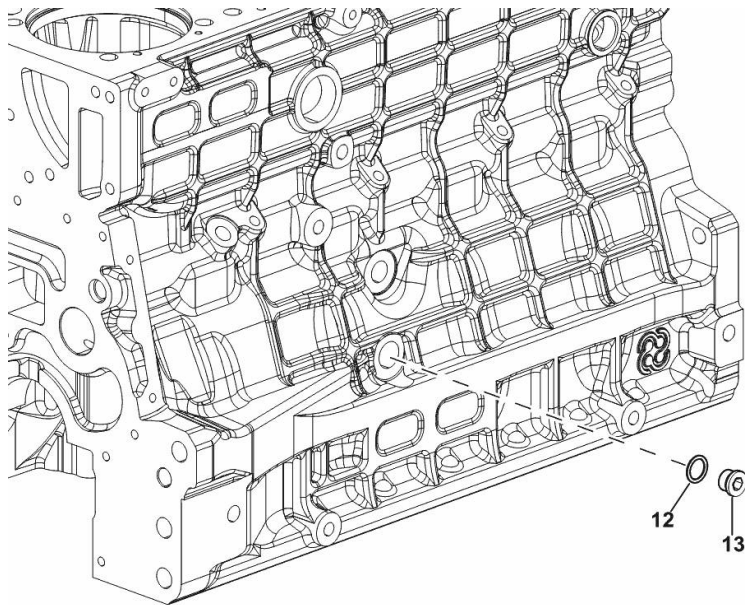

9_K8015_03_0-B-001

<https://www.ebooklibonline.com>

Hello dear friend!

Thank you very much for reading.

Enter the link into your browser.

The full manual is available for immediate download.

<https://www.ebooklibonline.com>

MONOBLOC ENGINE-GEARBOX CONNECTING FLANGE

Fig.	P/n	QTY	Name
------	-----	-----	------

Notes:

[EXPLORER 90.4 -> ZKDCF80200TS20001]

1	2.1475.005.2	2	washer 14
2	2.0112.524.2	2	screw m 14 p.2 x 75
3	2.0112.624.2	2	screw m 16 p.2 x 75
4	2.1475.006.2	2	spring washer 16
6	2.0439.250.7	1	stud bolt m 12 / m 10 x 30
7	0.011.9294.0/10	1	bush
25	0.019.1488.0	1	flange
26	2.0112.511.2	8	screw m 14 p.2 x 30
27	2.1651.912.0	2	cylindrical plug 12x28
28	2.1651.917.0	1	cylindrical plug 12x40
29	2.0432.257.7	1	stud bolt m 12 p.1.75 - 1.25 x 30

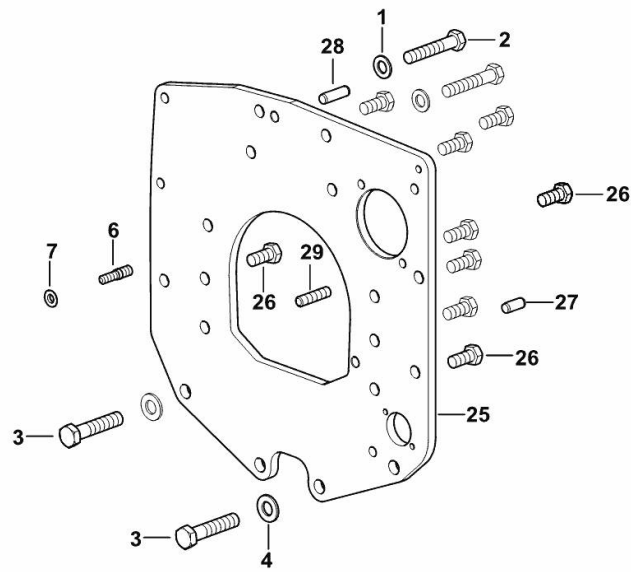

[9_K7411_01_0-A-001]

ENGINE FLYWHEEL

Fig.	P/n	QTY	Name
------	-----	-----	------

Notes:

[EXPLORER 90.4 -> ZKDCF80200TS20001]

1	0.019.2098.3	1	flywheel
1.2	0.065.1242.0	1	crown wheel Z = 123
2	0.255.2525.0/10	1	flange
3	2.0399.371.0	6	screw

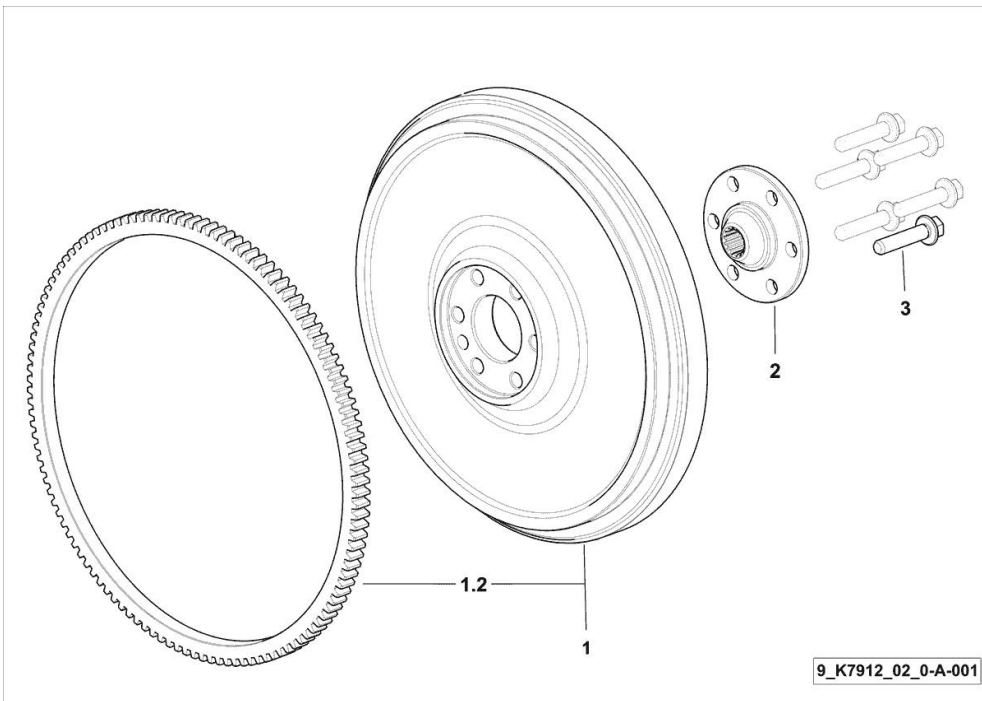

9_K7912_02_0-A-001

CRANKSHAFT PULLEY

Fig.	P/n	QTY	Name
------	-----	-----	------

Notes:

[EXPLORER 90.4 -> ZKDCF80200TS20001]

1	0.019.9925.0	1	pulley
2	0.019.6668.0	1	flange
3	0.065.1256.0	2	ring 45x52
4	2.1579.865.0	1	spacer 45.2x51.8x10
5	2.0439.195.7	1	stud bolt m 20 p.1.5x80
6	2.1019.094.7	1	nut m 20 p.1.5
7	2.0112.320.2	6	screw m 10 p.1.5 x 55
8	2.1470.006.2	6	lock washer 10
9	2.1720.006.0	1	key 4x6.5
10	0.019.6413.0	1	gear wheel
11	2.1651.505.0	1	cylindrical plug 6x12

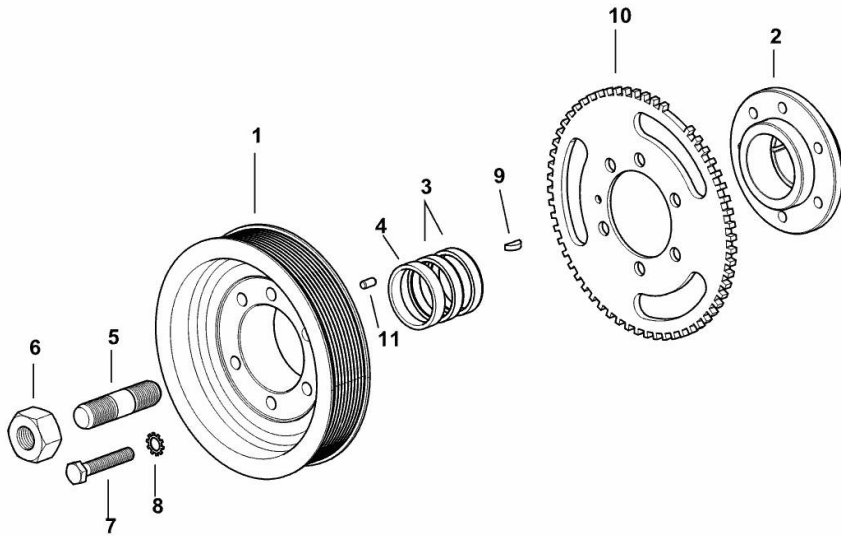

19_K7812_01_0-A-001

BELT AND TENSIONER

Fig.	P/n	QTY	Name
------	-----	-----	------

Notes:

- WITH MANUAL AIR CONDITIONING [EXPLORER 90.4 -> ZKDCF80200TS20001]

1	2.4119.218.0/10	1	belt PK 10 L=2017
3	0.019.9869.4/10	3	pulley guide
4	2.0312.214.2	5	screw m 8 p.1.25 x 40
5	0.020.4604.0	1	support
7	2.0399.380.2	1	screw
8	2.0399.379.2	1	small column
9	2.1480.015.2	1	washer 10
10	2.1480.014.2	5	washer 8
11	2.1310.004.2	2	flat washer 8.4x17
13	2.0112.209.2	2	screw m 8 p 1.25 x 25

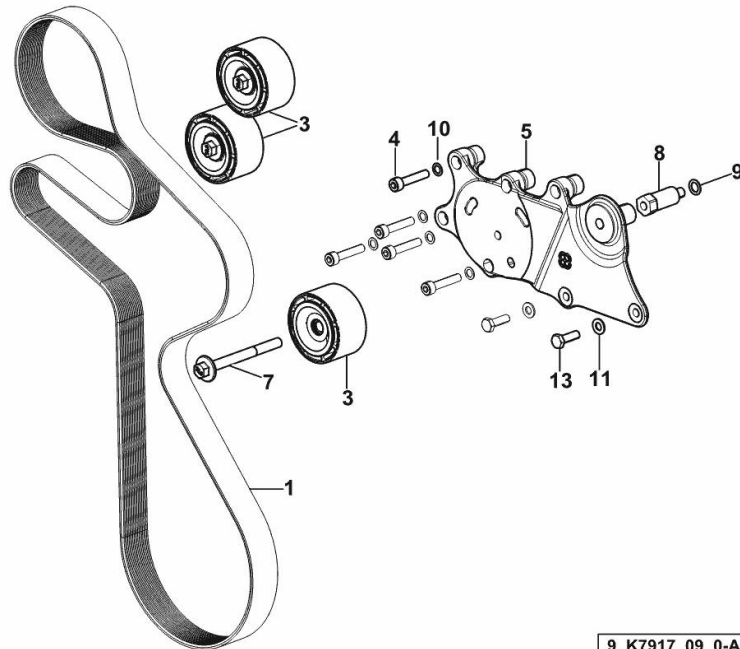

9_K7917_09_0-A-002

BELT AND TENSIONER

Fig.	P/n	QTY	Name
------	-----	-----	------

Notes:

WITHOUT AIR-CONDITIONING [EXPLORER 90.4 -> ZKDCF80200TS20001]

1	2.4119.219.0	1	belt PK 10 L=1498
3	0.019.9869.4/10	2	pulley guide
4	2.0312.214.2	5	screw m 8 p.1.25 x 40
5	0.020.4604.0	1	support
7	2.0399.380.2	1	screw
8	2.0399.379.2	1	small column
9	2.1480.015.2	1	washer 10
10	2.1480.014.2	5	washer 8
11	2.1310.004.2	2	flat washer 8.4x17
13	2.0112.209.2	2	screw m 8 p 1.25 x 25

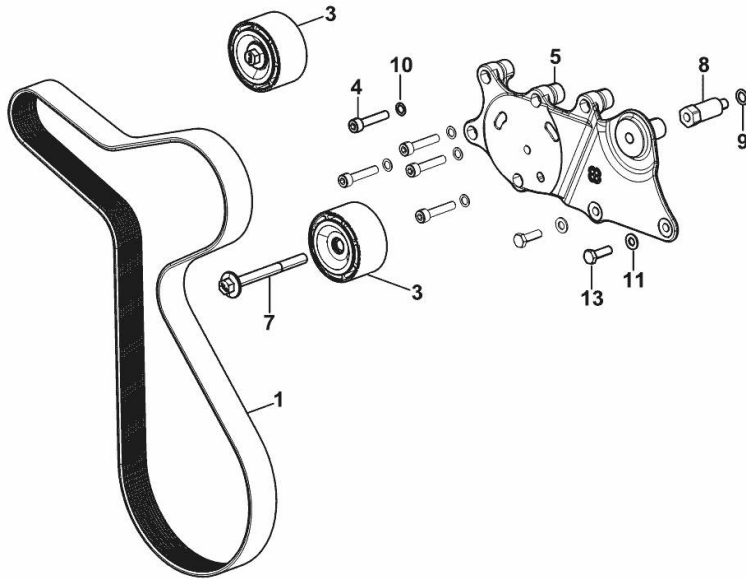

9_K7917_10_0-A-002

TENSION ROLLER

Fig.	P/n	QTY	Name
------	-----	-----	------

Notes:

[EXPLORER 90.4 -> ZKDCF80200TS20001]

1	0.019.9867.4	1	tensioner
2	2.1310.006.2	1	flat washer 10.5x21
3	2.0314.322.2	1	screw

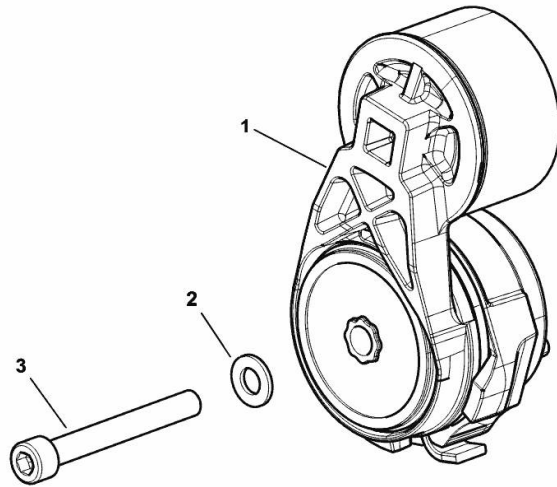

9_IB117_10_0-A-001

CRANKSHAFT

Fig.	P/n	QTY	Name
------	-----	-----	------

Notes:

[EXPLORER 90.4 -> ZKDCF80200TS20001]

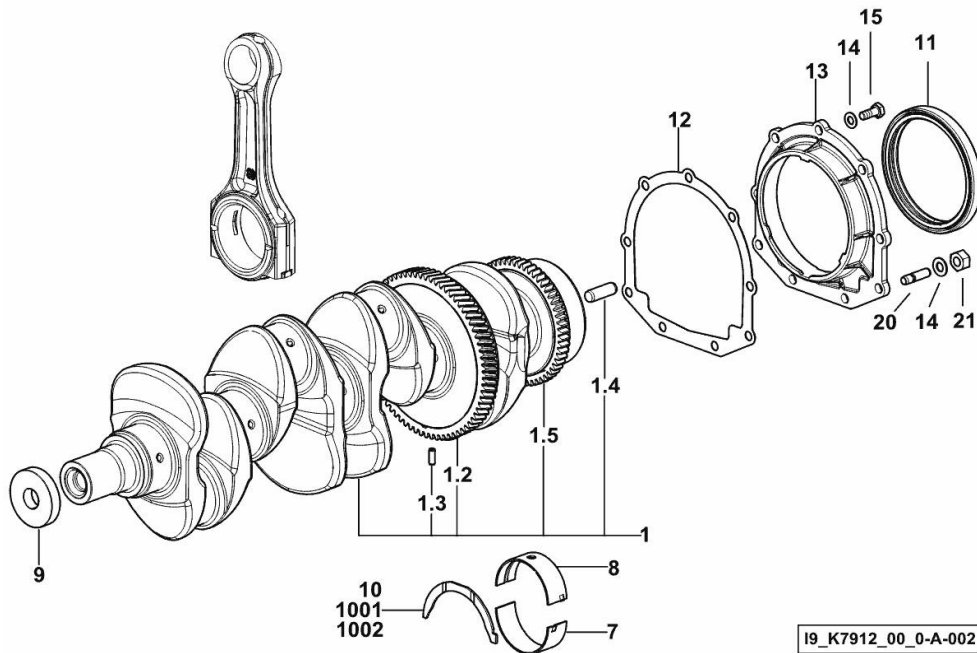

1	0.019.2251.3/10	1	crankshaft
1.2	0.065.1211.0/10	1	crown wheel
1.3	2.1630.608.0	1	pin 6x16
1.4	2.1651.915.0	1	pin 12x35
1.5	0.007.0855.0/10	1	gear
7	0.019.5456.0	5	main half bushing STANDARD
8	0.019.5455.0	5	main half bushing STANDARD
9	2.1599.524.7	1	washer 21x60x12
10	0.065.1218.0	4	shim STANDARD
11	2.1529.073.0	1	special oil seal 110x130x13
12	0.065.1254.0/20	1	gasket
13	0.007.0851.0/10	1	cover
14	2.1475.002.2	9	conical washer 8
15	2.0112.207.2	7	screw m 8 p 1.25 x 20
20	2.0432.003.7	2	stud bolt m 8 p.1.25 / p.1 x 20
21	2.1011.405.2	2	nut m 8 p.1
1001	0.065.1218.7		shim + mm 0.10
1002	0.065.1218.8		shim + mm 0.15

I9_K7912_00_0-A-002

CRANKSHAFT GEAR

Fig.	P/n	QTY	Name
------	-----	-----	------

Notes:

[EXPLORER 90.4 -> ZKDCF80200TS20001]

1	0.019.4145.0	1	gear z = 33
2	2.1720.006.0	1	key 4x6.5

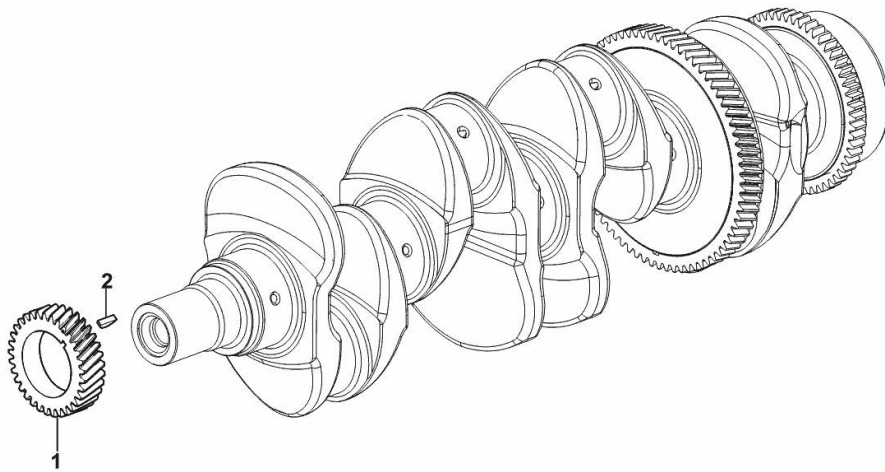

I9_K7913_00_0-D-001

COUNTERWEIGHTS

Fig.	P/n	QTY	Name
------	-----	-----	------

Notes:

[EXPLORER 90.4 -> ZKDCF80200TS20001]

25	2.1589.139.0	1	shoulder ring mm 0.3
26	2.1589.140.0	3	shoulder ring mm 0.1
29	2.1579.628.0	3	spacer 16.5x26x0.1
33	2.1579.629.0	6	spacer 12.5x26x0.1
34	2.1589.048.0	1	shoulder ring 16.5x26x0.3
35	2.1589.049.0	1	shoulder ring 12.5x26x0.3
38.1.1	0.086.1231.0/10	1	box
38.1.2	2.3130.001.1	4	plug 1/8" gas
38.2	0.086.1233.3/30	1	mass sx/lh/li
38.2.2	2.1559.115.0	2	special bushing 26x30x30
38.2.4	2.1651.302.0	1	roll pin 4x6
38.3	0.065.1233.3/30	1	mass dx/rh/re
38.3.2	2.1559.115.0	2	special bushing 26x30x30
38.3.4	2.1651.302.0	1	roll pin 4x6
38.3.5	2.1410.018.1	1	circlip 45
38.4.1	0.065.1234.0/10	1	shaft
38.4.2	2.3130.001.1	1	plug 1/8" gas
38.5	2.1631.717.0	2	roll pin 8 x 40
38.6	2.1589.185.0	4	shoulder ring 26.1x34x1
38.7	2.0522.212.7	1	screw m 8 p.1.25 x 30
44	2.1579.626.0	2	spacer 13.2x16x11
45	2.0139.028.2	4	screw m 12
46	2.1699.191.0	1	bush 7x10x16

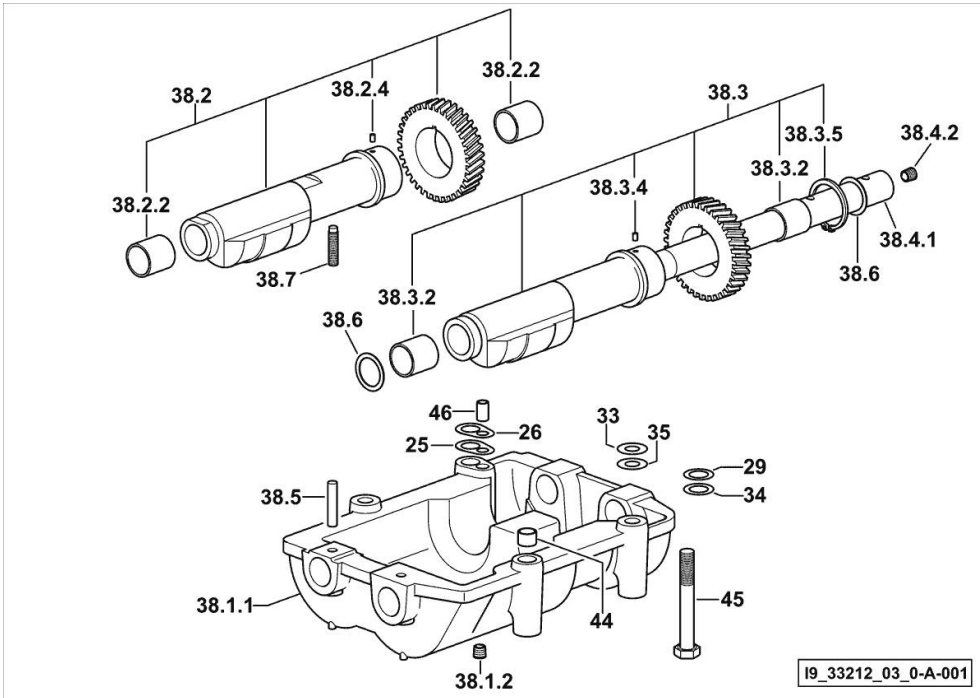

CYLINDER - PISTON - CONNECTING ROD

Fig.	P/n	QTY	Name
------	-----	-----	------

Notes:

[EXPLORER 90.4 -> ZKDCF80200TS20001]

2	0.019.2226.3/10	4	engine connecting rod
2.1	2.0399.365.0	2	screw m 10 p.1.25x61.5
2.3	2.1559.532.0	1	special bushing 34.60x39.130x36.65
3	0.019.4180.0/10	4	piston
4	0.019.4717.0/30	4	engine cylinder
5	0.019.5453.0	4	con.rod half bushing STANDARD - A = 29.85 -> 30.10
6	0.019.5454.0	4	con.rod half bushing STANDARD - A = 29.85 -> 30.10
17	0.019.4187.0	4	piston pin
18	0.019.4188.0	8	circlip 35
19	0.019.4199.6	4	piston ring set
22	2.0399.365.0	8	screw m 10 p.1.25x61.5
500	0.K77.0065.6	4	cyl. piston assembly
600	0.K77.0060.6	4	complete piston

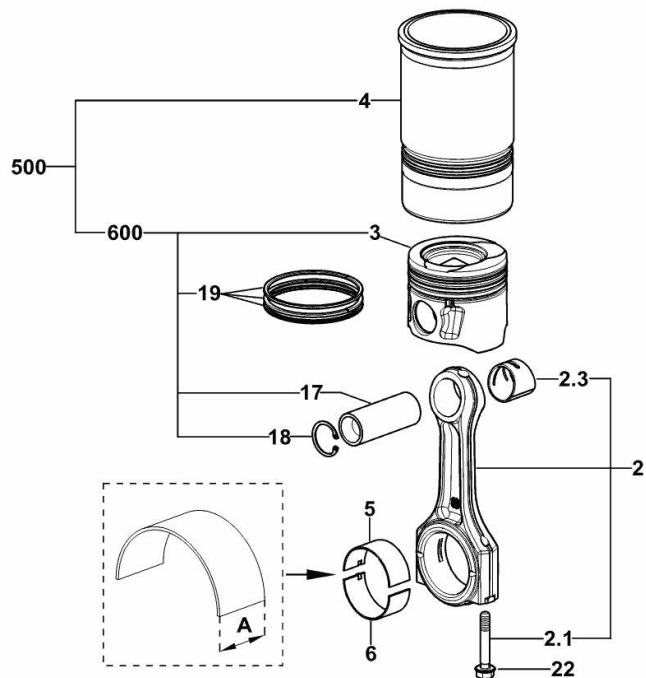

19_K7912_00_0-C-001



Suggest:

For more complete manuals. Please go to the home page.

<https://www.ebooklibonline.com>

If the above button click is invalid. Please download this document first, and then click the above link to download the complete manual.

Thank you so much for reading

CAMSHAFT

Fig.	P/n	QTY	Name
------	-----	-----	------

Notes:

[EXPLORER 90.4 -> ZKDCF80200TS20001]

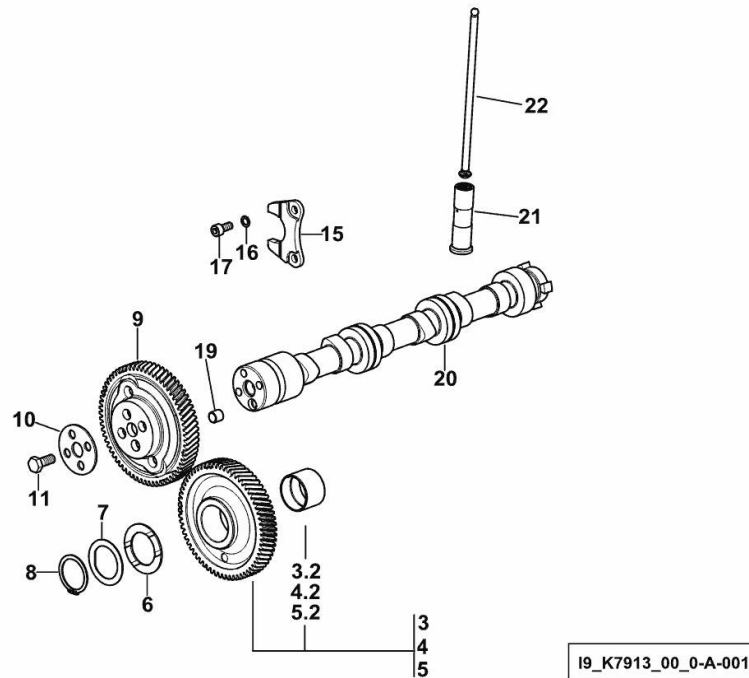

3	0.019.4874.3	0.4	gear Z=64 - WITH RED IDENTIFICATION STAMP
3.2	2.1559.185.0/10	1	bushing
4	0.019.4875.3	0.3	gear Z=64 - WITH GREEN IDENTIFICATION STAMP
4.2	2.1559.185.0/10	1	bushing
5	0.019.4876.3	0.3	gear Z=64 - WITH YELLOW IDENTIFICATION STAMP
5.2	2.1559.185.0/10	1	bushing
6	0.018.2233.0	2	shoulder ring
7	0.065.1352.0	1	shim
8	2.1410.016.1	1	circlip 40
9	0.019.4147.0	1	gear z=66
10	0.065.1350.0	1	small disc
11	2.0132.207.2	4	screw m 10 p.1 x 25
15	0.065.1353.0	1	small plate
16	2.1480.014.1	2	washer 8
17	2.0312.205.2	2	screw
19	2.1559.398.0	1	bushing 10.5x13x12
20	0.019.2505.0/10	1	camshaft
21	0.019.5378.3	8	tappets
22	0.019.1069.2	8	rod

TIMING CASE

Fig.	P/n	QTY	Name
------	-----	-----	------

Notes:

[EXPLORER 90.4 -> ZKDCF80200TS20001]

2	0.019.2123.0/10	1	gasket
3	0.019.2122.0/20	1	cover
4	2.1480.014.2	17	washer 8
6	2.0312.214.2	9	screw m 8 p.1.25 x 40
7	2.0312.208.2	8	screw m 8 p.1.25 x 25
8	2.1529.167.0	1	oil seal
19	0.020.0875.0	1	cover
20	2.1539.097.0	1	special oil seal 75.87 x 2.62
21	2.1480.012.2	3	washer 6, d128
22	2.0312.102.2	3	screw m 6 p.1 x 12

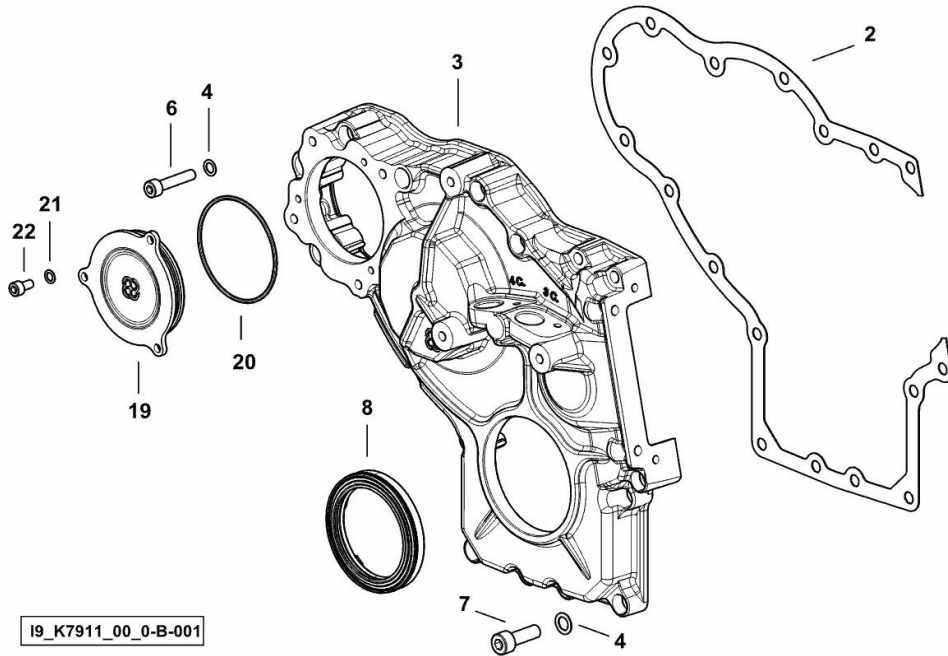

<https://www.ebooklibonline.com>

Hello dear friend!

Thank you very much for reading.

Enter the link into your browser.

The full manual is available for immediate download.

<https://www.ebooklibonline.com>