

Section: B0 - ENGINE

CRANKCASE

Fig.	P/n	QTY	Name
------	-----	-----	------

Notes:

[DORADO F 70 -> 6001]

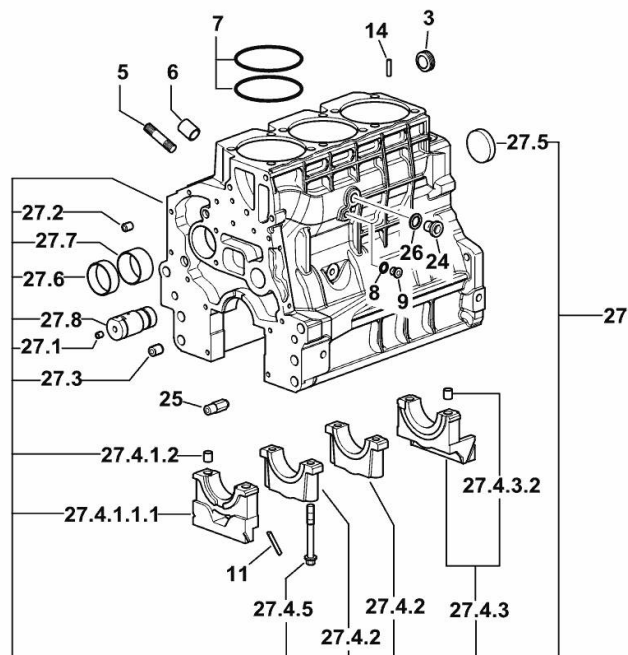

3	2.3199.312.2/20	1	plug m 35x1.5x9.5
5	2.0439.273.7	6	stud bolt m 8
6	2.1559.188.2	3	bush 11.4 x 14 x16
7	2.1539.259.0	6	special oil seal 107.62x2.62
8	2.1560.010.0	1	gasket 14.2 x 20
9	2.3199.292.0	1	plug 1/4" gas
11	0.066.1152.0/10	4	gasket
14	2.1549.154.2	3	bush 4.8x5.8x16
24	2.3120.101.0	1	plug m 18 p.1.5
25	0.013.4946.0/10	1	sprayer nozzle
26	2.1560.014.0	1	washer 18.2 x 24
27	0.015.2793.4/10	1	crankcase
27.1	2.3130.001.1	9	plug 1/8" gas
27.2	2.3130.002.1	2	plug 1/4" gas
27.3	2.3130.003.1	2	plug 3/8" gas
27.4.1.1.1	0.065.1112.7/10	1	support
27.4.1.2	2.1699.165.0	1	bush 12.3x15x16
27.4.2	0.065.1114.0/10	2	support
27.4.3	0.065.1116.3	1	support
27.4.3.2	2.1699.165.0	1	bush 12.3x15x16
27.4.5	0.065.1117.0	8	screw m 12 x 100
27.5	2.3179.012.0	1	plug 60
27.6	0.065.1140.0	3	special bushing 59X55X20
27.7	0.065.1141.0	1	special bushing 59X55X30
27.8	0.014.1340.0/10	1	pin mm 85

CRANKCASE

Fig.	P/n	QTY	Name
------	-----	-----	------

Notes:

- EXPORT U.S.A. [DORADO F 70 -> 6001]

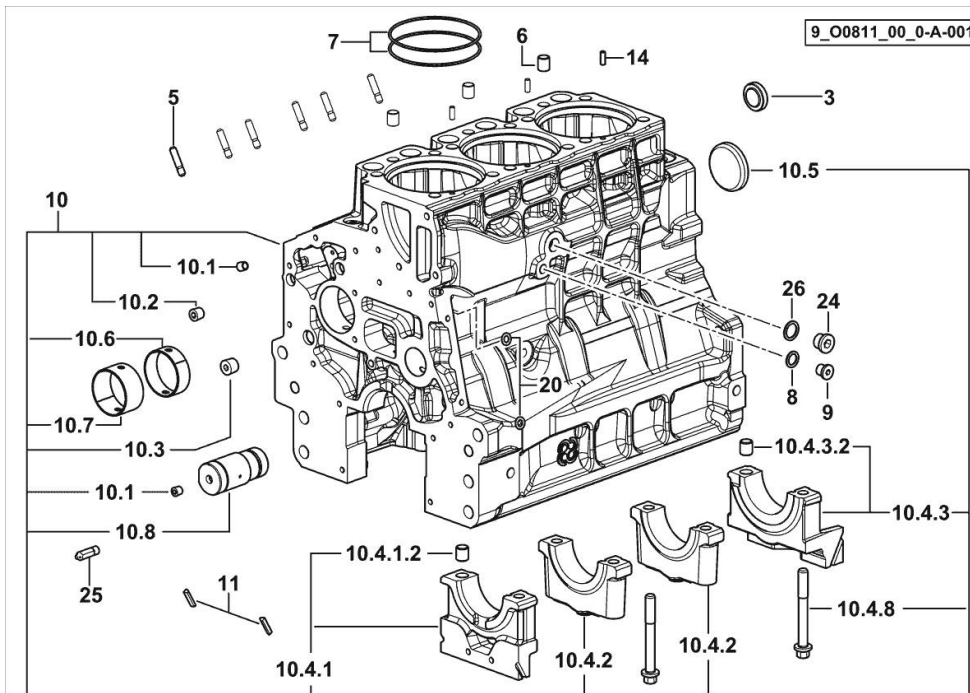

3	2.3199.312.2/20	1	plug m 35x1.5x9.5
5	2.0439.279.7	6	stud bolt m 8 p.1 x 25
6	2.1559.188.2	3	bush 11.4 x 14 x16
7	2.1539.259.0	6	special oil seal 107.62x2.62
8	2.1560.010.0	1	gasket 14.2 x 20
9	2.3199.292.0	1	plug 1/4" gas
10	0.014.9911.4/30	1	crankcase
10.1	2.3130.001.1	12	plug 1/8" gas
10.2	2.3130.002.1	4	plug 1/4" gas
10.3	2.3130.003.1	2	plug 3/8" gas
10.4.1	0.065.1112.3	1	support
10.4.1.2	2.1699.165.0	1	bush 12.3x15x16
10.4.2	0.065.1114.0/10	2	support
10.4.3	0.065.1116.3	1	support
10.4.3.2	2.1699.165.0	1	bush 12.3x15x16
10.4.8	0.065.1117.0	8	screw m 12 x 100
10.5	2.3179.012.0	1	plug 60
10.6	0.065.1140.0	3	special bushing 59X55X20
10.7	0.065.1141.0	1	special bushing 59X55X30
10.8	0.014.1340.0/10	1	pin mm 85
11	0.066.1152.0/10	4	gasket
14	2.1549.154.2	3	bush 4.8x5.8x16
20	2.1470.004.2	4	lock washer 8
24	2.3120.101.0	1	plug m 18 p.1.5
25	0.013.4946.0/10	1	sprayer nozzle
26	2.1560.014.0	1	washer 18.2 x 24

MONOBLOC ENGINE-GEARBOX CONNECTING FLANGE

Fig.	P/n	QTY	Name
------	-----	-----	------

Notes:

[DORADO F 70 -> 6001]

1	0.007.7752.0/30	1	flange
2	2.0112.511.2	8	screw m 14 p.2 x 30
3	2.1651.912.0	2	cylindrical plug 12x28
4	2.1651.917.0	1	cylindrical plug 12x40
5	2.0432.257.7	1	stud bolt m 12 p.1.75 - 1.25 x 30
6	2.0439.250.7	1	stud bolt m 12 / m 10 x 30
7	0.011.9294.0/10	1	bush

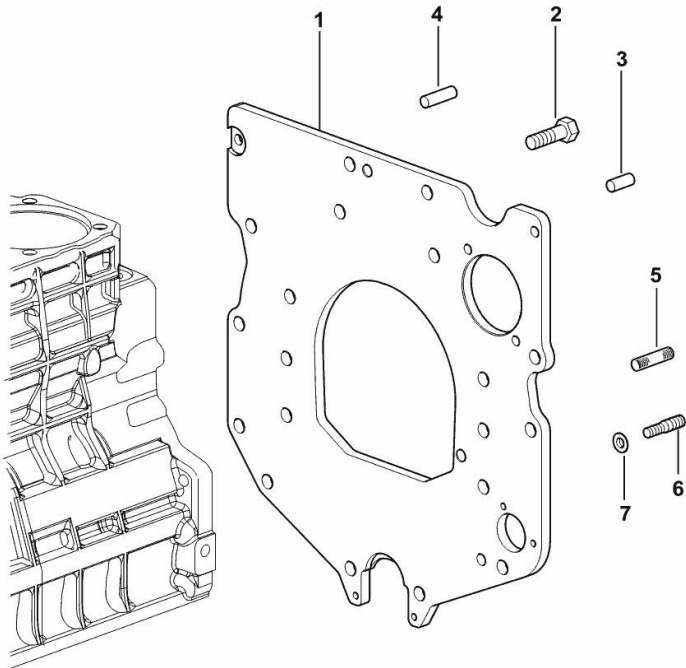

9_37311_01_0-A-001

<https://www.ebooklibonline.com>

Hello dear friend!

Thank you very much for reading.

Enter the link into your browser.

The full manual is available for immediate download.

<https://www.ebooklibonline.com>

Section: B0 - ENGINE

CRANKSHAFT PULLEY

Fig.	P/n	QTY	Name
------	-----	-----	------

Notes:

[DORADO F 70 -> 6001]

1	0.013.6349.0/10	1	pulley
2	0.011.3515.0/20	1	hub Z = 48
3	0.065.1256.0	2	ring 45x52
4	2.1579.865.0	1	spacer 45.2x51.8x10
5	2.0439.195.7	1	stud bolt m 20 p.1.5x80
6	2.1019.094.7	1	nut m 20 p.1.5
7	2.0112.320.2	6	screw m 10 p.1.5 x 55
8	2.1470.006.2	6	lock washer 10

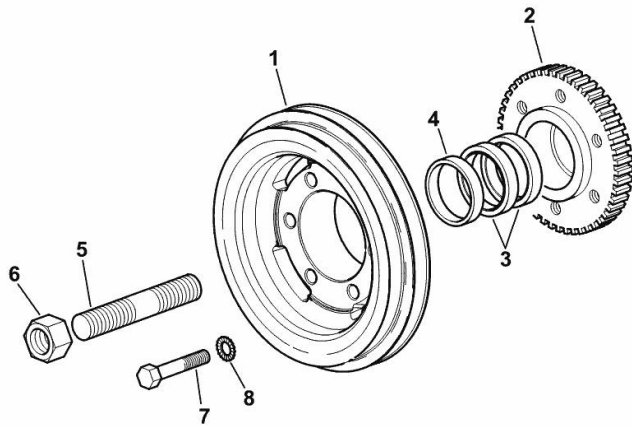

9_N1412_03_0-A-001

COOLANT PUMP AND ALTERNATOR DRIVEBELT

Fig.	P/n	QTY	Name
------	-----	-----	------

Notes:

[DORADO F 70 -> 6001]

1	2.4119.177.0	1	belt AV 12.7x1285 mm
---	--------------	---	----------------------

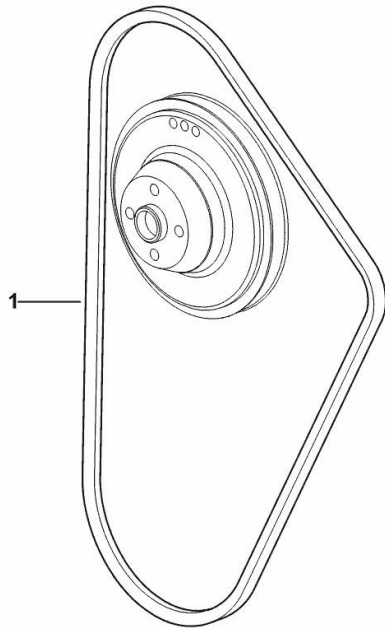

9_N4817_02_0-A-001

COOLANT PUMP AND ALTERNATOR DRIVEBELT

Fig.	P/n	QTY	Name
------	-----	-----	------

Notes:

- FOR MODELS WITH COMPRESSOR [DORADO F 70 -> 6001] 6029 <-

1	2.4119.149.0/10	1	belt AV 13x1262 mm
2	2.4119.143.0	1	belt AV 12.7x1225 mm

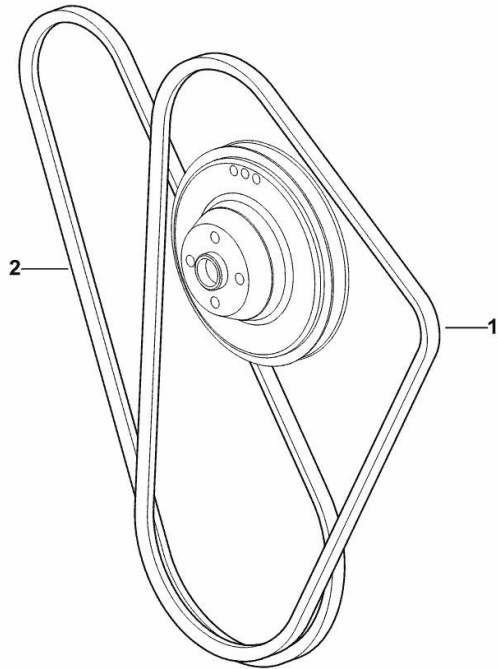

9_N1417_04_0-A-001

COOLANT PUMP AND ALTERNATOR DRIVEBELT

Fig.	P/n	QTY	Name
------	-----	-----	------

Notes:

- FOR MODELS WITH COMPRESSOR [DORADO F 70 -> 6001] -> 6034

1	2.4119.177.0	1	belt AV 12.7x1285 mm
2	2.4119.143.0	1	belt AV 12.7x1225 mm

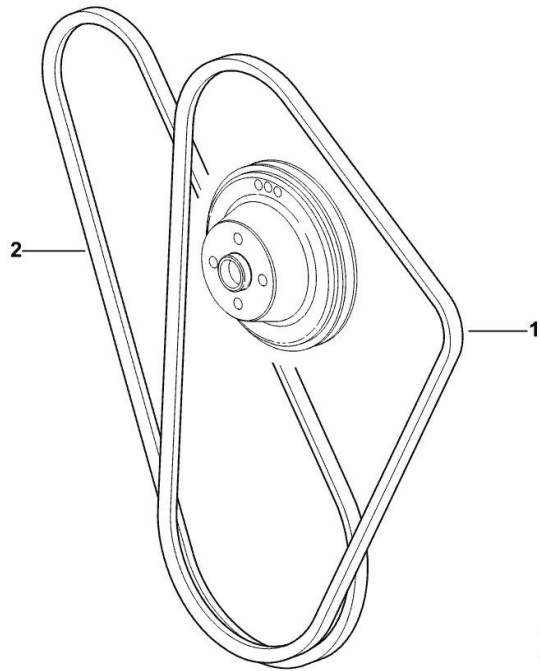

9_N4917_04_0-A-001

Section: B0 - ENGINE

CRANKSHAFT

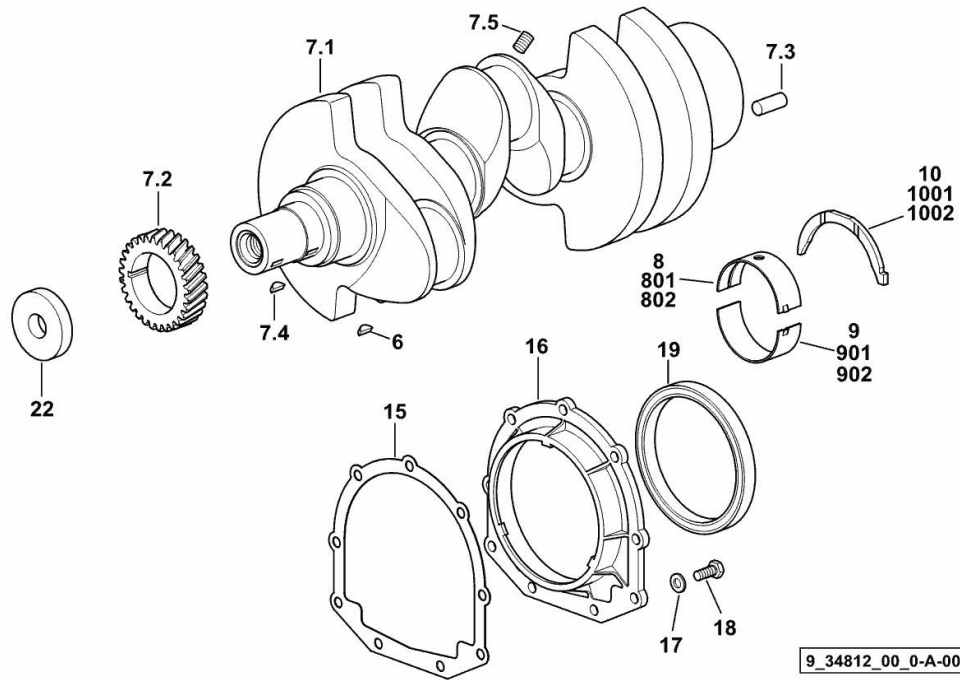

Fig.	P/n	QTY	Name
------	-----	-----	------

Notes:

[DORADO F 70 -> 6001]

6	2.1720.006.0	1	key 4x6.5
7.1	0.007.1554.0/20	1	crankshaft
7.2	0.065.1323.0/30	1	gear Z = 29
7.3	2.1651.915.0	1	pin 12x35
7.4	2.1720.006.0	1	key 4x6.5
7.5	2.3130.001.1	3	plug 1/8" gas
8	0.065.1215.0/10	4	main half bushing STANDARD
9	0.065.1216.0/10	4	main half bushing STANDARD
10	0.065.1218.0	4	shim STANDARD
15	0.065.1254.0/20	1	gasket
16	0.007.1711.0/10	1	cover
17	2.1475.002.2	9	conical washer 8
18	2.0112.207.2	9	screw m 8 p 1.25 x 20
19	2.1529.073.0	1	special oil seal 110x130x13
22	2.1599.524.7	1	washer 21x60x12
801	0.065.1215.7		main half bushing - mm 0.25
802	0.065.1215.8		main half bushing - mm 0.50
901	0.065.1216.7		main half bushing - mm 0.25
902	0.065.1216.8		main half bushing - mm 0.50
1001	0.065.1218.7		shim + mm 0.10
1002	0.065.1218.8		shim + mm 0.15

9_34812_00_0-A-001

ENGINE FLYWHEEL

Fig.	P/n	QTY	Name
------	-----	-----	------

Notes:

[DORADO F 70 -> 6001]

1	0.007.1883.3/30	1	flywheel
1.2	0.069.1242.0	1	crown wheel Z = 121
2	0.255.2525.0/10	1	flange
3	2.0139.022.2	6	screw m 12 p.1.25x55

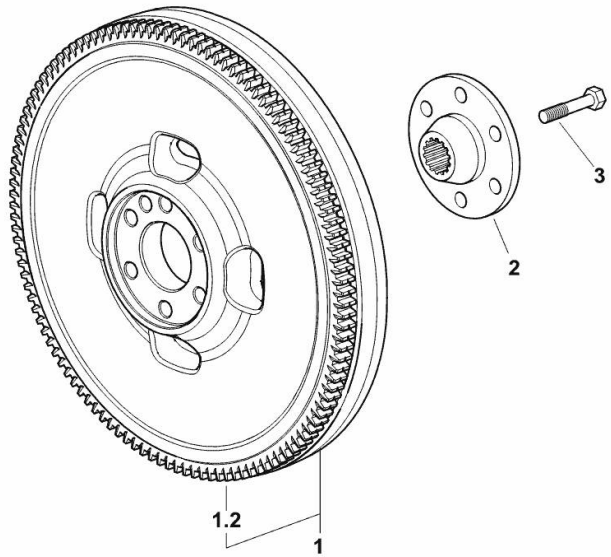

9_37212_08_0-A-001

ENGINE FLYWHEEL

Fig.	P/n	QTY	Name
------	-----	-----	------

Notes:

- EXPORT U.S.A. [DORADO F 70 -> 6001]

50	0.011.2162.3/10	1	flywheel
50.2	0.069.1242.0	1	crown wheel Z = 121
51	0.255.2525.0/10	1	flange
52	2.0139.022.2	6	screw m 12 p.1.25x55

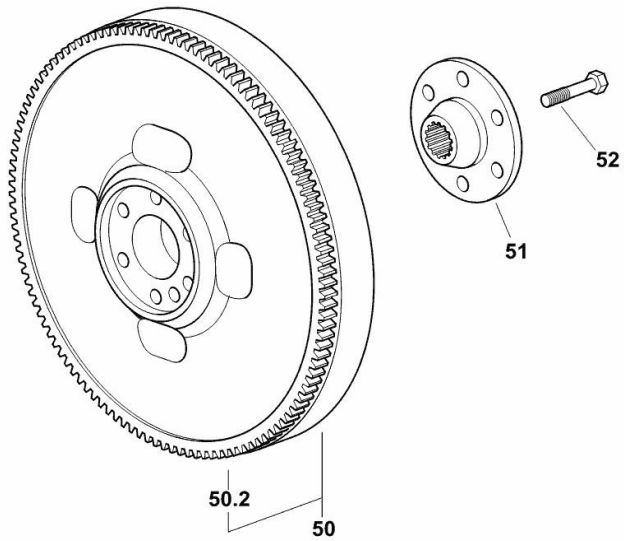

9_37412_01_0-A-001

CYLINDER - PISTON - CONNECTING ROD

Fig.	P/n	QTY	Name
------	-----	-----	------

Notes:

[DORADO F 70 -> 6001]

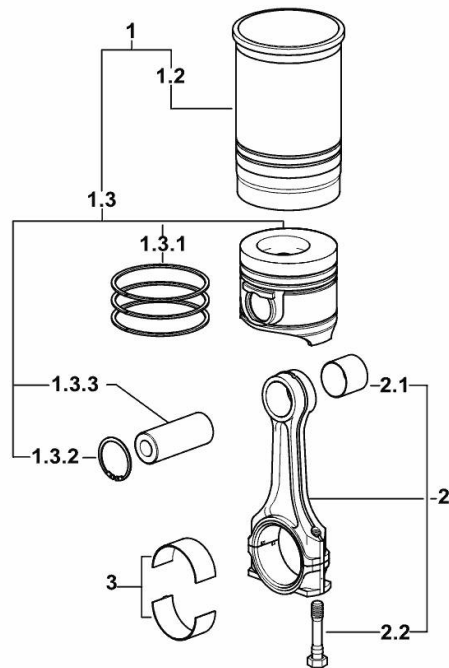

9_M8312_01_M-A-001

1	0.023.0065.A	3	cyl. piston assembly "A" - CLASS A
1	0.023.0065.B	3	cyl. piston assembly "B" - CLASS B
1.2	0.A12.2675.0	1	engine cylinder "A" - CLASS A
1.2	0.B12.2675.0	1	engine cylinder "B" - CLASS B
1.3	0.023.0060.A	1	complete piston "A" - CLASS A
1.3	0.023.0060.B	1	complete piston "B" - CLASS B
1.3.1	0.338.0052.6/20	1	piston ring set
1.3.2	2.1411.014.1	2	circlip 35
1.3.3	0.078.1236.0	1	piston pin Ø 18 / Ø 35 / L = mm 86
2	0.078.1220.3/30	3	engine connecting rod
2.1	2.1559.114.0/10	1	special bushing
2.2	2.0399.213.0	2	screw m 12 p.1.25x61.5
3	0.065.1225.0	6	con.rod half bushing STANDARD - A = 28.75 -> 29.00
3	0.065.1225.7	6	con.rod half bushing - mm 0.25
3	0.065.1225.8	6	con.rod half bushing - mm 0.50

Section: B0 - ENGINE

GUARD PLATE

Fig.	P/n	QTY	Name
------	-----	-----	------

Notes:

[DORADO F 70 -> 6001]

1	0.007.1262.3/50	1	guard
2	0.007.1271.0/10	1	small column m 8 p.1.25 / L = mm 60
3	0.007.1272.0/10	2	small column m 8 p.1.25 / L = mm 50
5	2.1310.004.2	3	flat washer 8.4x17
7	2.0112.203.2	3	screw m 8 p.1.25 x 12

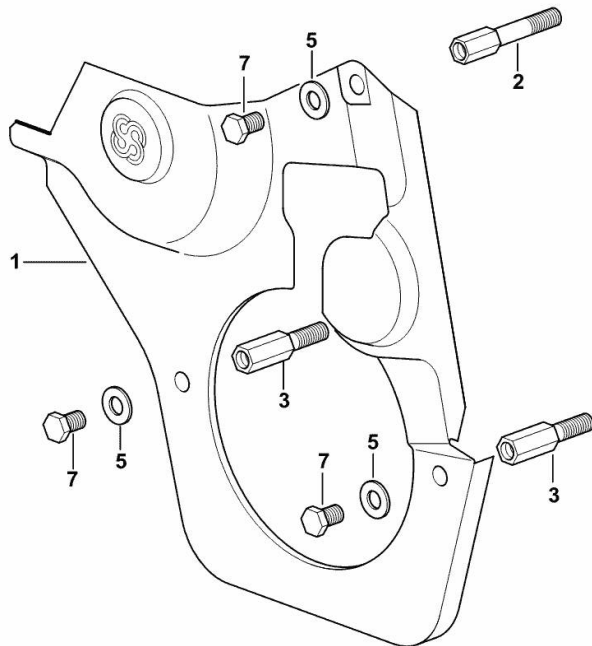

9_33011_02_0-A-001

Section: B0 - ENGINE

TIMING CASE

Fig.	P/n	QTY	Name
------	-----	-----	------

Notes:

[DORADO F 70 -> 6001]

15	2.0432.003.7	2	stud bolt m 8 p.1.25 / p.1 x 20
16	2.0312.214.2	7	screw m 8 p.1.25 x 40
17	2.1480.014.1	15	washer 8
18	0.013.4981.0	1	guard
19	0.065.1150.0/30	1	gasket
20	2.1470.004.2	4	lock washer 8
21	2.1011.405.2	2	nut m 8 p.1
22	2.0312.208.2	8	screw m 8 p.1.25 x 25
23	2.1529.167.0	1	oil seal

9_M6511_00_0-B-001

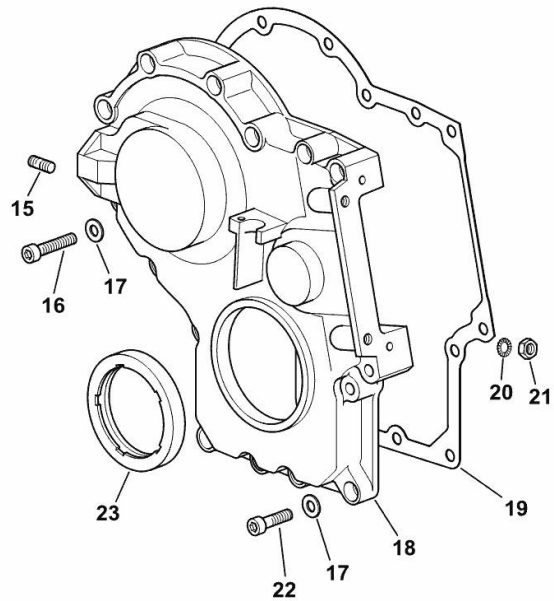



Suggest:

For more complete manuals. Please go to the home page.

<https://www.ebooklibonline.com>

If the above button click is invalid. Please download this document first, and then click the above link to download the complete manual.

Thank you so much for reading

TIMING CASE

Fig.	P/n	QTY	Name
------	-----	-----	------

Notes:

- EXPORT U.S.A. [DORADO F 70 -> 6001]

15	2.0432.003.7	2	stud bolt m 8 p.1.25 / p.1 x 20
16	2.0312.214.2	7	screw m 8 p.1.25 x 40
17	2.1480.014.1	15	washer 8
18	0.013.4981.0	1	guard
19	0.065.1150.0/30	1	gasket
20	2.1470.004.2	4	lock washer 8
21	2.1011.405.2	2	nut m 8 p.1
22	2.0312.208.2	8	screw m 8 p.1.25 x 25
23	2.1529.167.0	1	oil seal

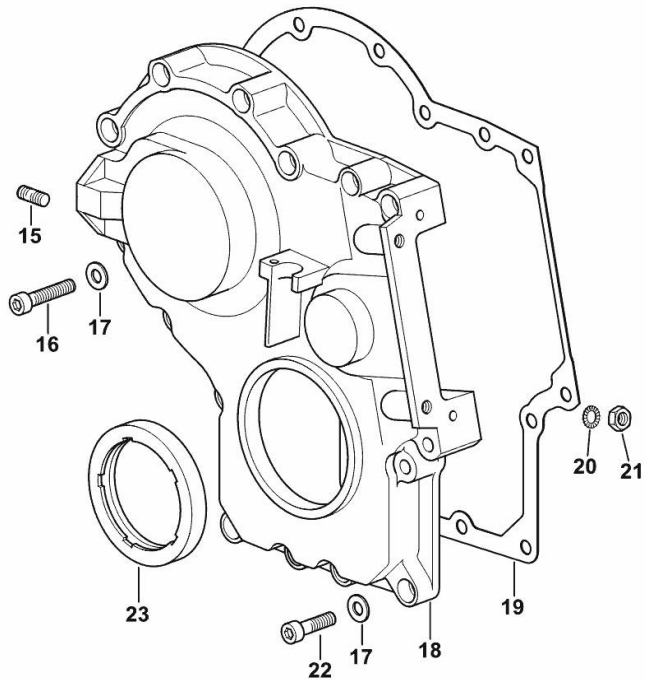

9_O0811_00_0-B-001

Section: B0 - ENGINE

CASING COVER

Fig.	P/n	QTY	Name
------	-----	-----	------

Notes:

[DORADO F 70 -> 6001]

30	0.065.1152.0	1	gasket
31	0.013.6374.2	1	cover
32	0.013.6368.0/20	4	stud bolt m 8 p.1 / = mm 51.5
34	2.1310.004.2	8	flat washer 8.4x17
35	2.1011.405.2	4	nut m 8 p.1

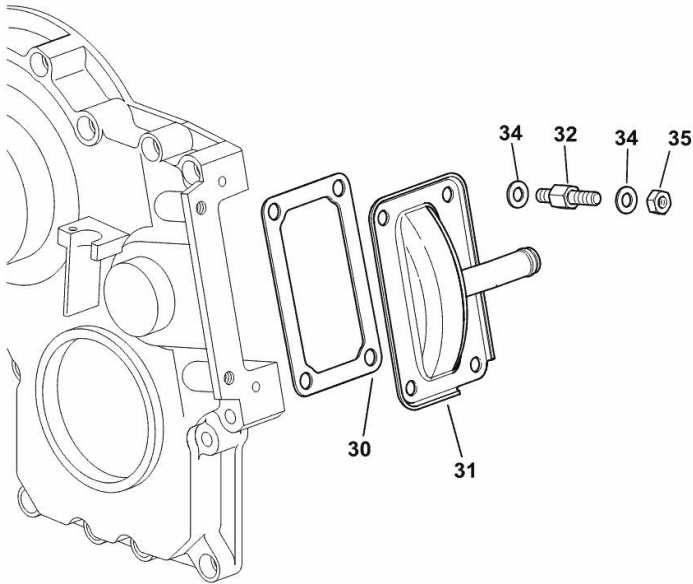

9_N1411_01_0-A-001

<https://www.ebooklibonline.com>

Hello dear friend!

Thank you very much for reading.

Enter the link into your browser.

The full manual is available for immediate download.

<https://www.ebooklibonline.com>