

## Section: ENGINE

## CRANKCASE

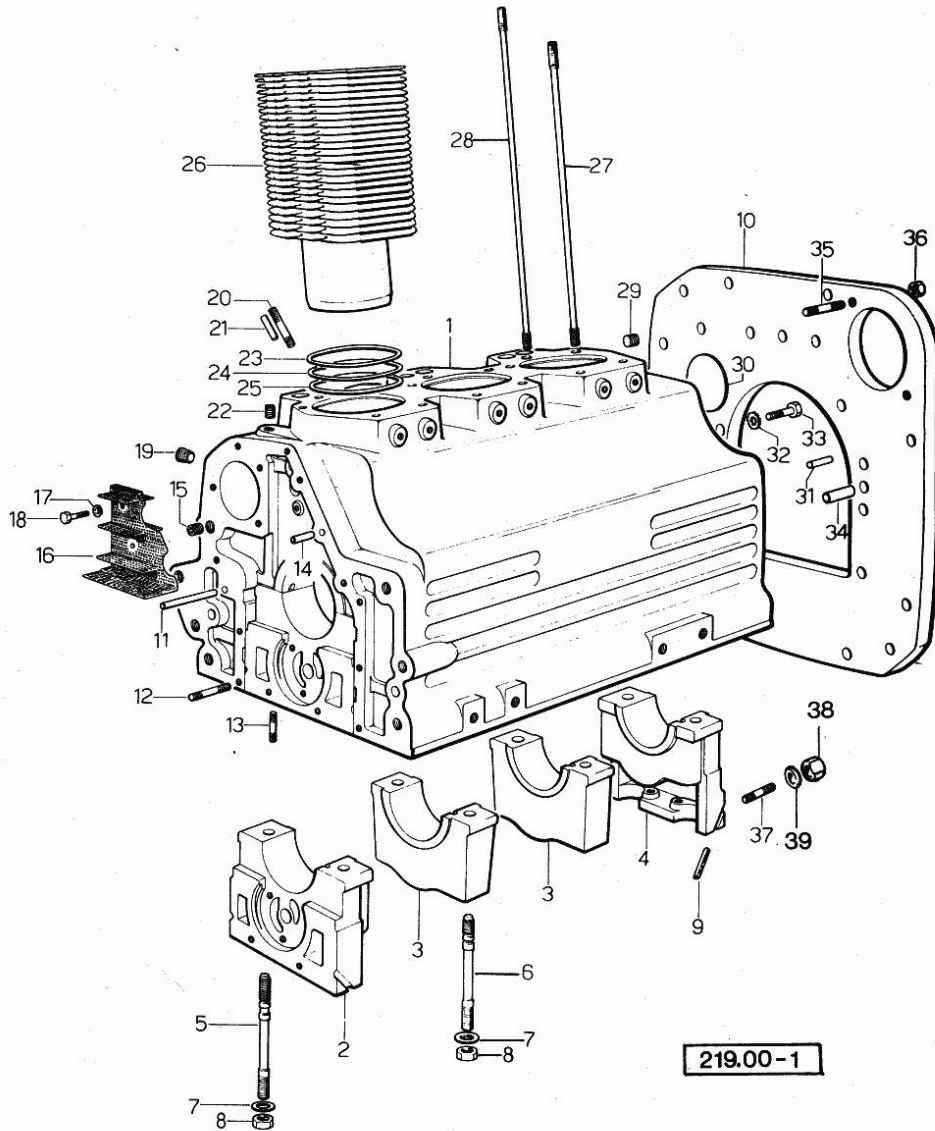

Fig.	P/n	QTY	Name
<b>Notes:</b>			
[Condor C]			
0	0.035.0050.6/10	1	gasket set FOR ENGINE ASSEMBLY
1	0.035.1110.4/30	1	crankcase
2	0.004.8776.0	1	support
3	0.029.1113.0	2	support
4	0.029.1116.0	1	support
5	0.021.1157.0	4	stud bolt
6	0.029.1117.0	4	stud bolt
7	2.1599.144.7	8	shoulder ring 12.5x23x4
8	2.1019.026.7	8	special nut m 12 p.1.5
9	0.029.1154.0	4	gasket
10	0.027.1130.0/20	1	flange
11	2.1699.116.0	1	pin
12	2.0432.018.1	5	stud bolt m 8 p.1.25 / p.1 x 65
13	2.0432.003.1	24	stud bolt m 8 p.1.25 / p.1 x 20
14	2.1699.021.0	1	pin 7.8x8x20
15	2.3130.002.1	1	plug 1/4" gas
16	0.029.1155.2/20	1	plate
17	2.1470.002.2	2	lock washer 6
18	2.0112.002.2	2	screw m 6 p.1 x 10
19	2.3139.001.1	3	plug
20	2.0432.267.1	2	stud bolt m 12 p.1.75-1.25x60
21	2.1653.708.0	1	pin 8x18
22	2.3130.001.1	3	plug 1/8" gas
23	2.1569.055.0	3	shim
24	2.1589.037.0	3	shim
25	2.1589.036.0	3	shim
26	0.036.1120.0/10	3	engine cylinder
27	0.039.1122.0	12	stud bolt m 12 p.1.5x310
28	0.037.1122.0	3	stud bolt
29	2.3130.002.1	1	plug 1/4" gas
30	2.3170.022.1	1	expansion plug 60
31	2.1653.708.0	2	pin 8x18
32	2.1470.008.2	11	lock washer 14
33	2.0112.511.1	11	screw m 14 p.2 x 30
34	2.1652.911.0	2	cylindrical plug 12x25
35	2.0432.257.1	2	stud bolt m 12 p.1.75 - 1.25 x 30
36	2.1011.207.2	2	nut m 12 p.1.5
37	2.0432.153.1	2	stud bolt m 10 p.1.5 / p.1.25 x 20
38	2.1011.421.2	2	nut m 10 p.1.25
39	2.1474.010.1	2	spring washer 10

## Section: ENGINE

## TIMING CASE

Fig.	P/n	QTY	Name
------	-----	-----	------

## Notes:

[Condor C]

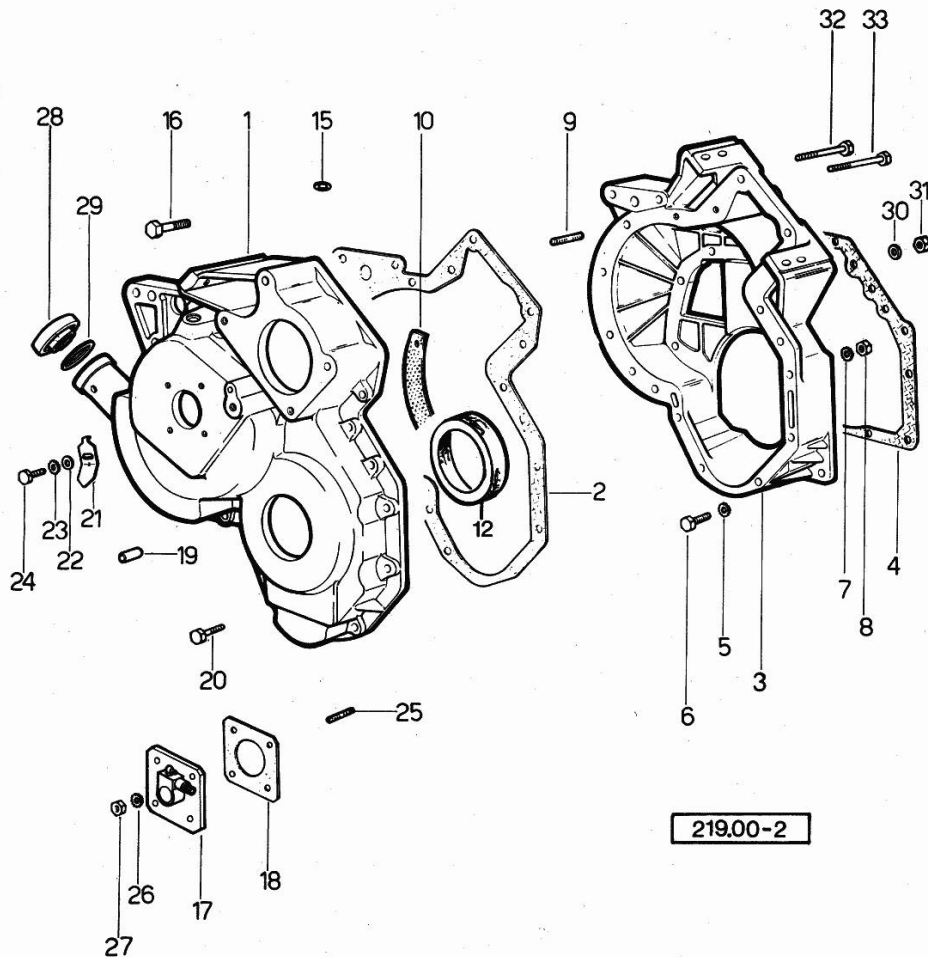

1	0.320.1554.0	1	governor housing
2	0.027.1156.0	1	gasket
3	0.027.1154.0/30	1	flange
4	0.029.1153.0/10	1	gasket
5	2.1474.009.1	8	spring washer 8
6	2.0112.207.2	8	screw m 8 p 1.25 x 20
7	2.1474.009.1	15	spring washer 8
8	2.1011.405.2	15	nut m 8 p.1
9	2.0439.060.2	3	stud bolt m 8 p.1.25-1x22
10	0.027.1152.0/20	1	small plate
12	2.1519.010.0	1	special oil seal 58x80x10
15	2.1530.028.0	1	oil seal 11.91 x 2.62
16	2.0122.222.2	1	screw
17	2.7049.210.0/20	1	transmission
18	0.026.1150.0	1	gasket
19	2.1653.711.0	1	pin
20	2.0122.213.2	4	screw m 8 p.1x35
21	0.027.1150.0/10	1	index
22	2.1310.003.2	1	flat washer 7.4x14
23	2.1470.004.2	1	lock washer 8
24	2.0112.204.2	1	screw m 8 p.1.25x14
25	2.0439.055.1	4	stud bolt m 6 p.1 x 18
26	2.1480.012.1	4	washer 6, d128
27	2.1011.103.2	4	nut m 6 p.1
28	2.3199.535.0	1	plug
29	2.1530.074.0	1	oil seal 28.17x3.53
30	2.1474.009.1	2	spring washer 8
31	2.1011.405.2	3	nut m 8 p.1
32	2.0122.225.2	1	screw m 8 p.1x80
33	2.0122.225.2	1	screw m 8 p.1x80

## Section: ENGINE

## CRANKSHAFT

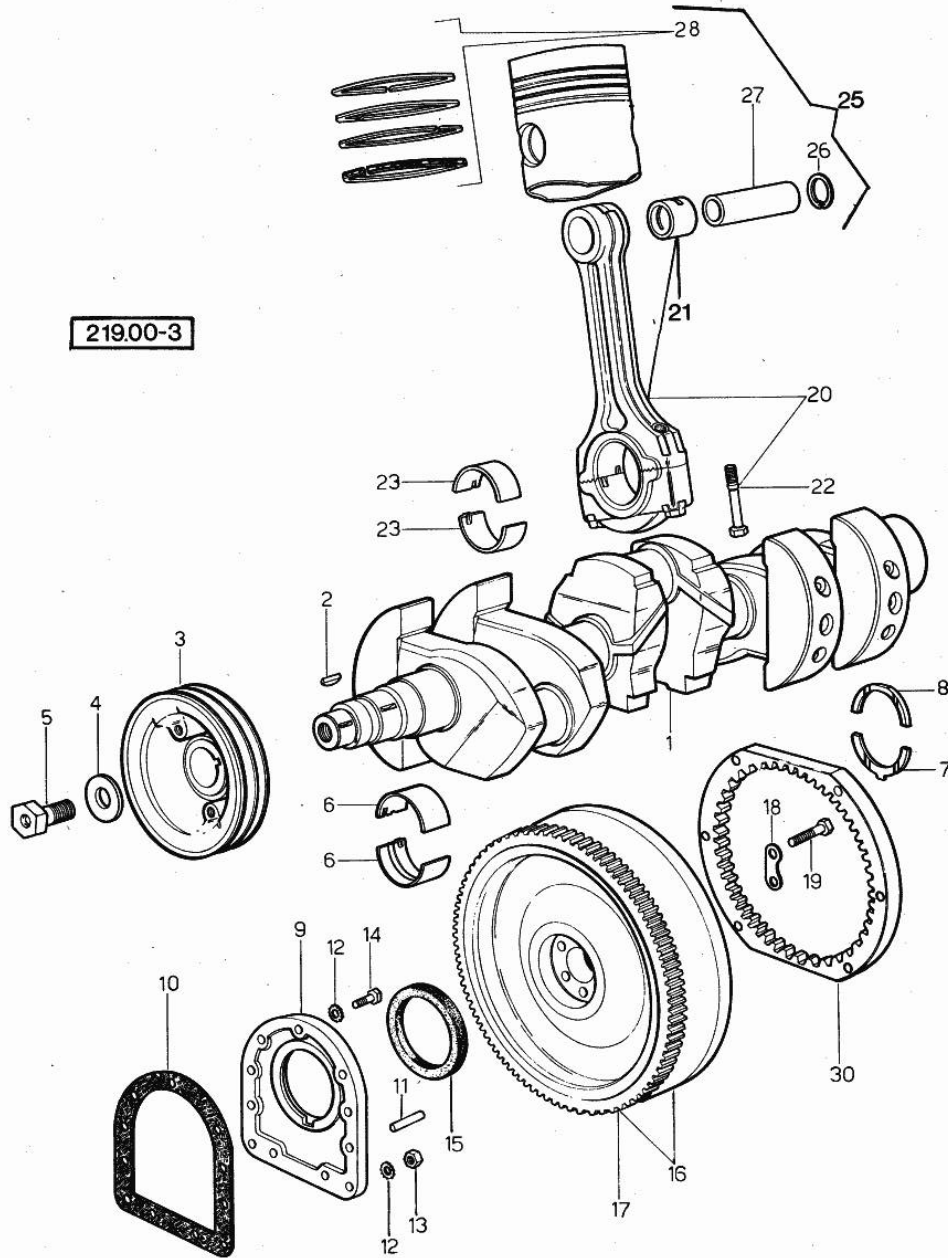

Fig.	P/n	QTY	Name
<b>Notes:</b>			
[Condor C]			
1	0.029.1210.4/30	1	crankshaft
2	2.1799.002.0	1	stick 10x13
3	0.035.1244.0/10	1	old part number
4	0.001.6020.0	1	shoulder
5	2.0129.032.2	1	screw m 24 p.2x45
6	0.029.0066.0		main half bushing - mm 1.00
6	0.029.1215.0/10	8	main half bushing
6	0.029.1215.7		main half bushing - mm 0.25
6	0.029.1215.8		main half bushing - mm 0.50
6	0.029.1215.9		main half bushing - mm 0.75
7	0.001.4547.0		shoulder ring + mm 0.05
7	0.001.4548.0		shoulder ring + mm 0.10
7	0.001.4549.0		shoulder ring + mm 0.15
7	0.042.1219.0	2	shoulder ring STANDARD
8	0.001.4544.0		shoulder ring + mm 0.05
8	0.001.4545.0		shoulder ring + mm 0.10
8	0.001.4546.0		shoulder ring + mm 0.15
8	0.042.1218.0	2	shoulder ring STANDARD
9	0.029.1240.0	1	flange
10	0.029.1250.0	1	gasket
11	2.1652.915.0	2	cylindrical plug 12x35
12	2.1474.010.1	7	spring washer 10
13	2.1011.421.2	2	nut m 10 p.1.25
14	2.0112.309.2	7	screw m 10 p.1.5 x 25
15	2.1519.009.0	1	special oil seal
16	0.038.1254.3	1	old part number
17	0.038.1242.0	1	crown wheel Z = 120, mm 15
18	2.1379.006.0	3	lock-tab 15x15x36,5
19	2.0122.515.7	6	screw
20	0.039.1220.3/20	3	engine connecting rod
21	0.002.4168.0	3	bearing
22	0.039.1250.0	6	screw m 14 p.1.5x63
23	0.039.0068.0		con.rod half bushing - mm 1.016
23	0.039.1225.0	6	con.rod half bushing
23	0.039.1225.7		con.rod half bushing -mm 0.254
23	0.039.1225.8		con.rod half bushing -mm 0.508
23	0.039.1225.9		con.rod half bushing -mm 0.762
25	0.036.0060.6	3	complete piston
25	0.036.0061.6		complete piston + mm 0.5
25	0.036.0062.6		complete piston + mm 1.00
26	2.1411.014.1	6	circlip 35

**<https://www.ebooklibonline.com>**

Hello dear friend!

Thank you very much for reading.

Enter the link into your browser.

The full manual is available for immediate download.

**<https://www.ebooklibonline.com>**

Section: ENGINE  
CRANKSHAFT

Fig.	P/n	QTY	Name
27	0.002.4167.0	3	piston pin
28	0.034.0052.6	3	piston ring set
28	0.034.0053.6	3	piston ring set + mm 0.5
28	0.034.0054.6	3	piston ring set + mm 1.0
30	0.038.1255.0	1	crown wheel

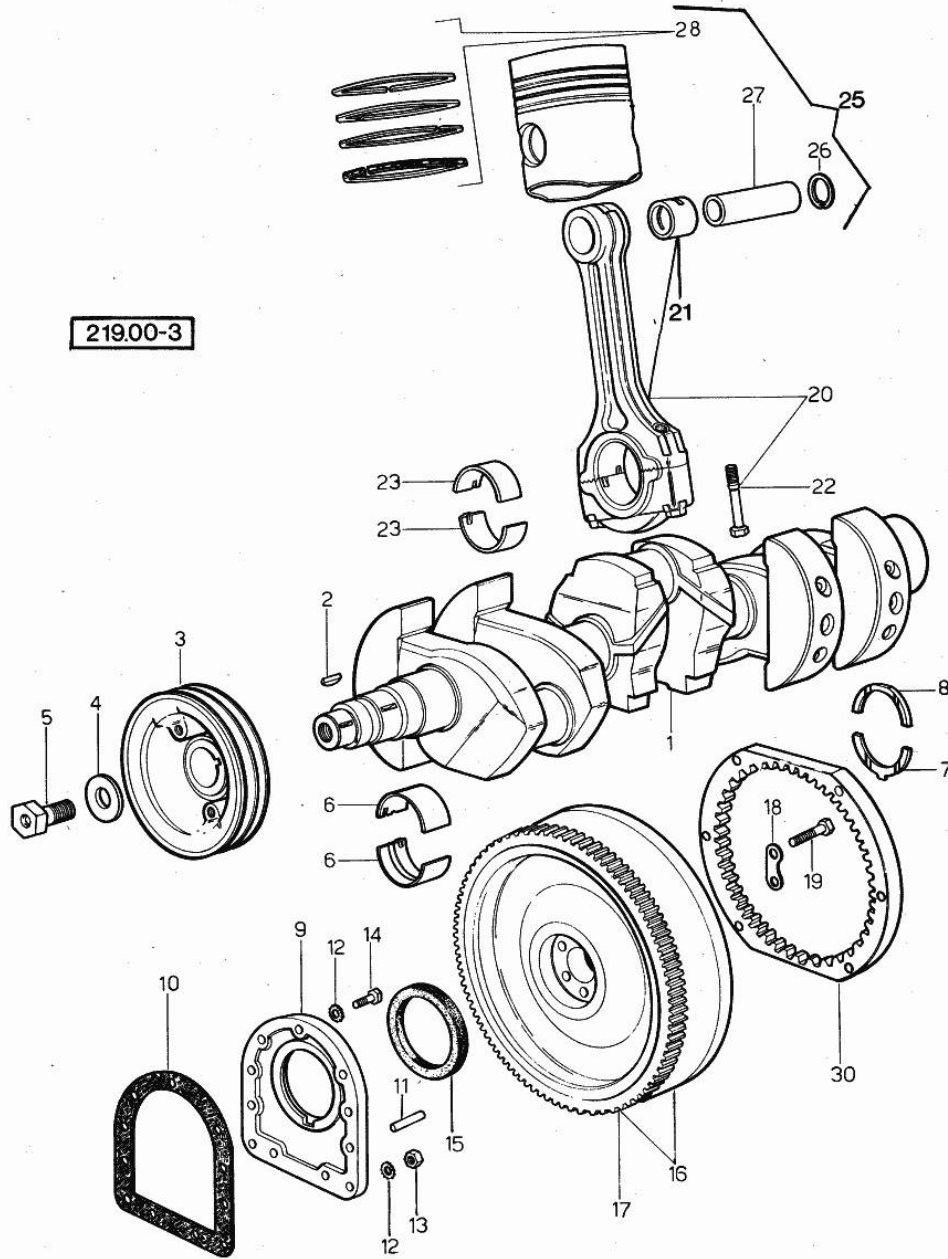

## Section: ENGINE

## CAMSHAFT

Fig.	P/n	QTY	Name
------	-----	-----	------

## Notes:

[Condor C]

1	0.035.1310.0/10	1	camshaft
2	0.027.1350.0/20	1	pin
3	0.027.1314.0	1	flange
4	2.1470.004.2	2	lock washer 8
5	2.0312.206.2	2	screw m 8 p 1.25 x 20
6	0.035.1321.0	1	gear
8	2.0139.006.1	4	screw
9	0.029.1320.0	1	gear Z = 45
10	2.1720.010.0	1	key 5x9
11	0.002.3909.0	6	tappets
12	0.037.1331.0	6	rod
13	2.1539.018.0	6	special oil seal
14	0.039.1332.0/10	6	sleeve
15	2.1539.022.0	6	special oil seal 12.37x2.62
16	2.4019.149.1	6	spring 14x29x2
17	2.1569.037.0	6	gasket
18	2.1650.513.0	1	pin 6 x 30

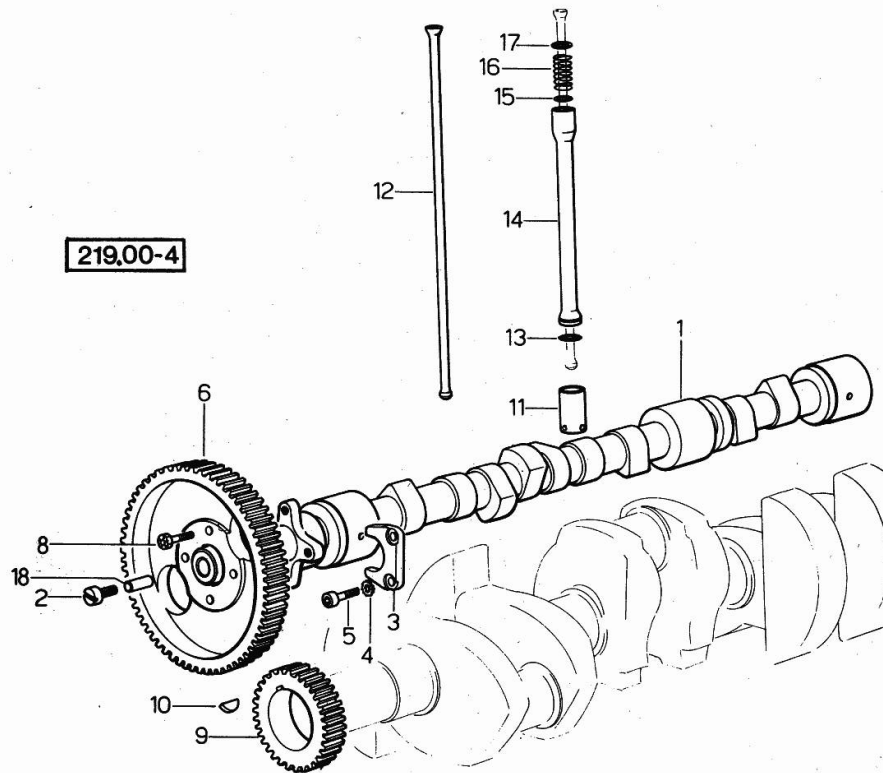

Section: ENGINE  
**CYLINDER HEAD**

Fig.	P/n	QTY	Name
<b>Notes:</b>			
[Condor C]			
0	0.034.0057.6	1	gasket set FOR 1 CYLINDER VALVE GRINDING AND PISTON RINGRENEWAL
1	0.037.1450.3/20	3	engine head
2	0.037.1416.0	3	valve guide
3	0.037.1417.0/10	3	valve guide
4	0.037.1451.0/10	3	valve seat
5	0.037.1452.0/10	3	valve seat
6	2.0432.007.1	6	stud bolt m 8 p.1.25 / p.1 x 30
7	0.029.1418.0	6	sleeve
8	2.1569.056.0/10	3	gasket
9	2.0439.087.1	6	stud bolt
10	2.1599.144.7	12	shoulder ring 12.5x23x4
11	2.1019.068.0	10	special nut
12	2.1019.069.0	5	special nut
13	0.029.1450.0	3	gasket
14	0.039.1440.0	3	cap
15	2.1560.004.0	3	copper gasket 8.2 x 14
16	2.1099.056.1	3	special nut m8 p.1
17	0.034.1430.0	3	support
18	0.029.1452.0	3	tube
19	0.034.1450.0	3	tappet gasket
20	002.5937.3/30	3	rocker arm
21	2.1559.021.0/40	3	bushing 15x19x22
22	0.002.5936.3/40	3	rocker arm
23	2.1559.021.0/40	3	bushing 15x19x22
24	0.029.1431.0	3	pin
25	2.0512.102.1	3	screw m 6 p.1 x 8
26	2.1599.019.0	6	shoulder ring 19.5x31x2
27	2.1410.055.1	6	circlip 19
28	0.021.1434.0	6	screw
29	2.1011.405.2	6	nut m 8 p.1
30	0.039.1451.0	3	stud bolt
31	0.039.1421.0	3	exhaust valve Ø mm 9
32	0.039.1420.0	3	inlet valve
33	2.4019.193.0	6	spring 36.15x55.2x3.2
34	2.4019.194.0	6	spring 22.70x50.7x2.1
35	0.002.9215.0	6	cup
36	0.002.9193.0	6	conical valve cotter
37	0.021.1453.0/20	6	small cover
38	2.1310.006.2	3	flat washer 10.5x21

Section: ENGINE

**CYLINDER HEAD**

Fig.	P/n	QTY	Name
39	2.1011.421.2	3	nut m 10 p.1.25
40	2.1599.160.7	3	flat washer
41	2.1099.035.7	3	special nut
42	2.3130.001.1	3	plug 1/8" gas

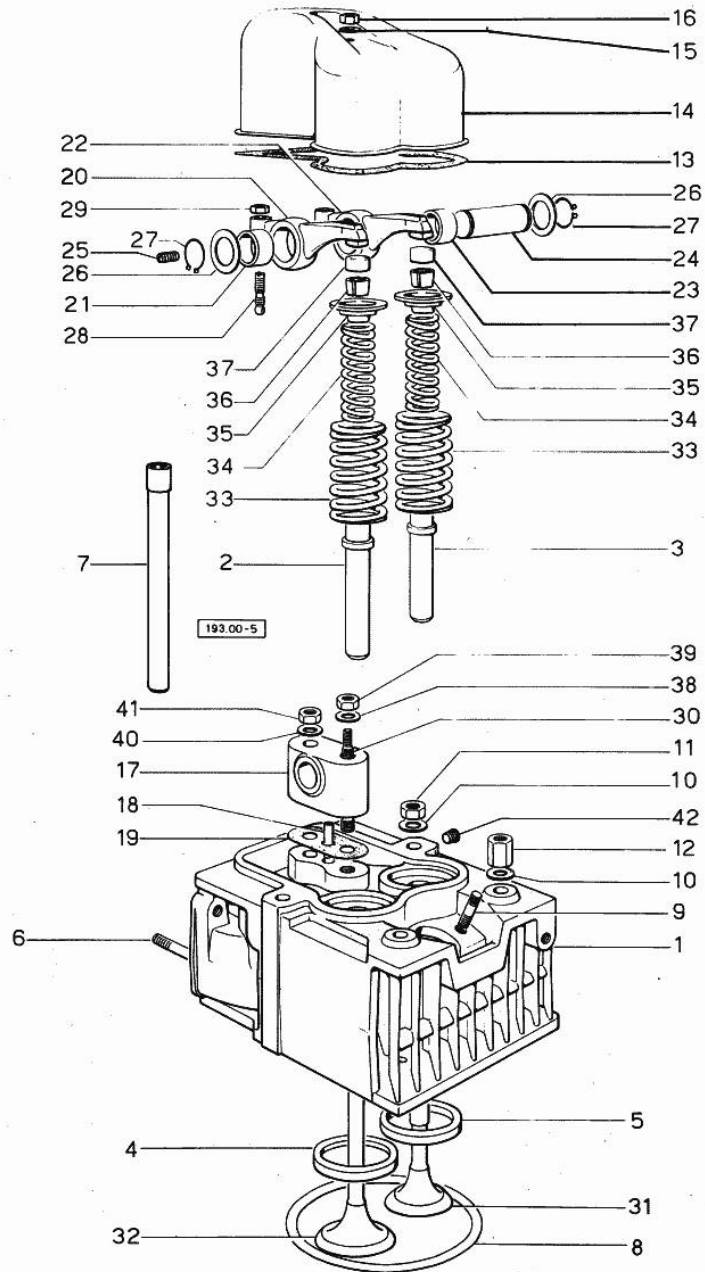
Section: ENGINE  
LUBRICATION

219.00 - 6

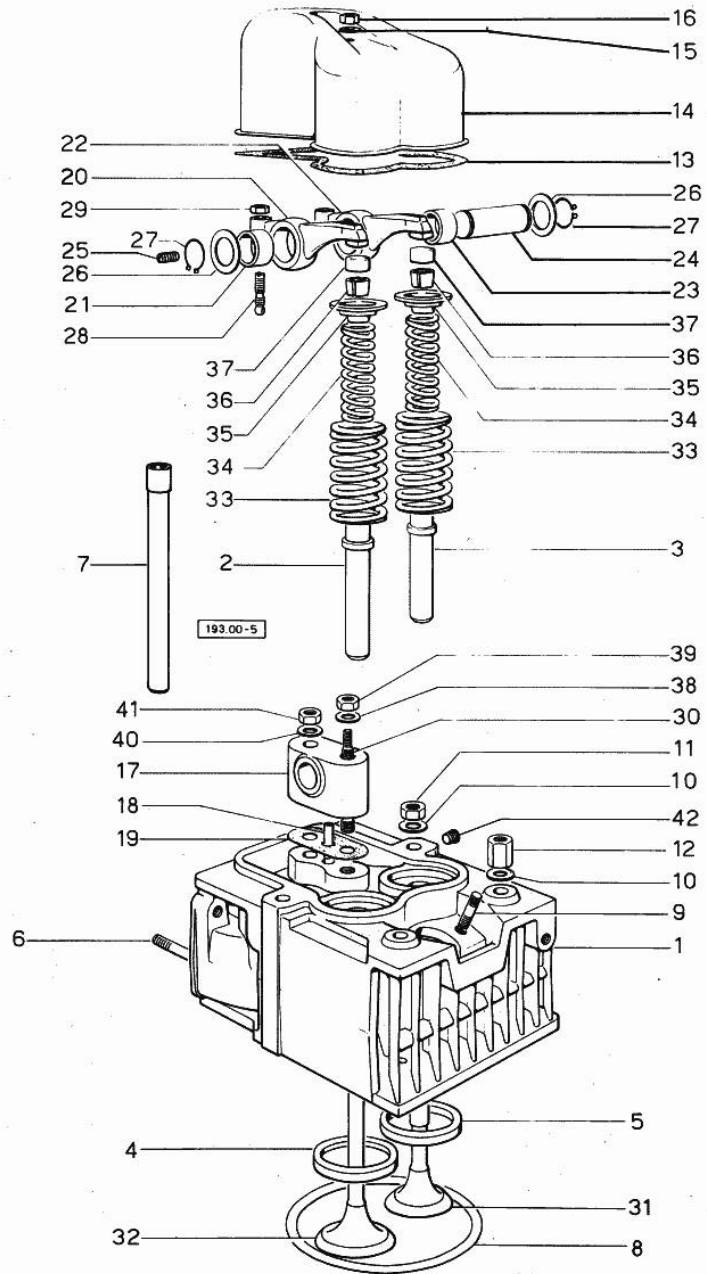
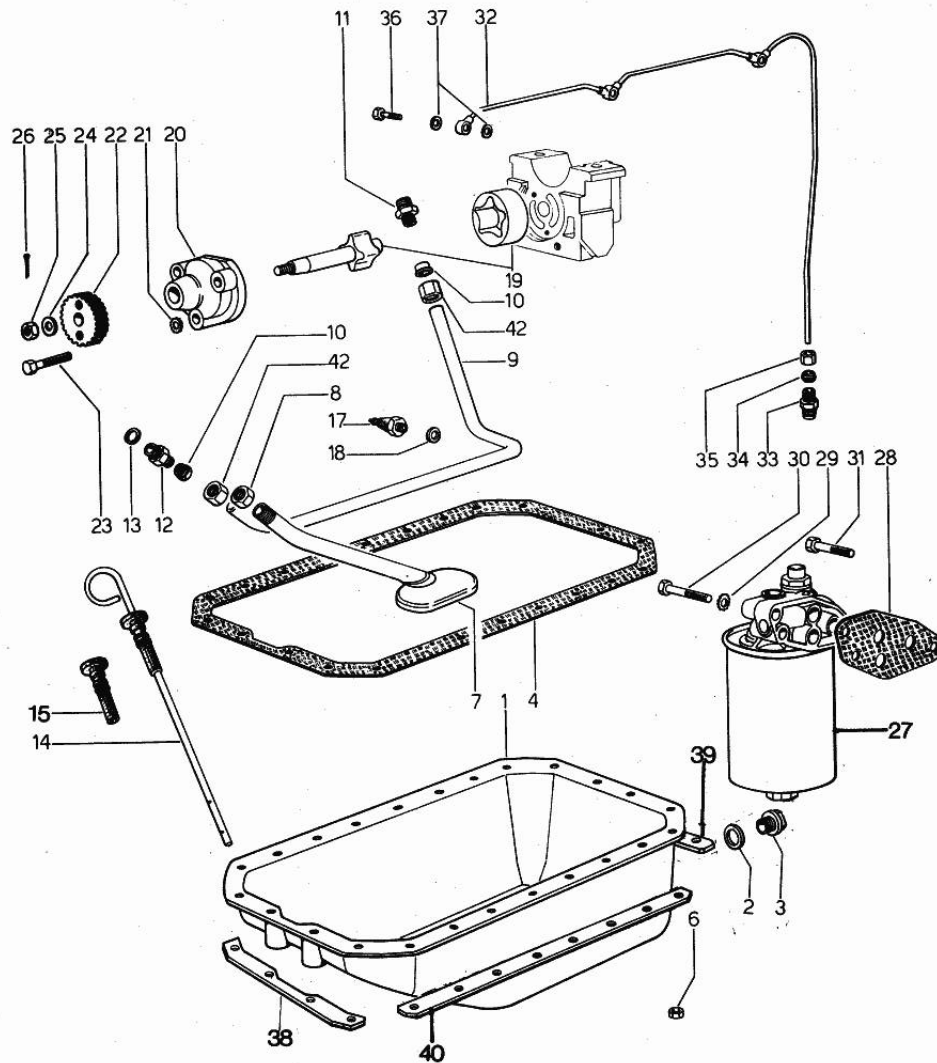

Fig.	P/n	QTY	Name
			<b>Notes:</b>
			[Condor C]
1	0.038.1556.0	1	oil sump
2	2.1560.054.0	1	gasket 21 x 26
3	2.3199.001.2	1	plug 1/2" gas
4	0.038.1555.0	1	gasket
6	2.1011.405.2	24	nut m 8 p.1
7	0.029.1531.3	1	tube
8	2.1099.026.1	1	special nut
9	0.029.1534.0	1	tube
10	2.3359.004.2	2	ring
11	2.3319.014.1	1	pipe union
12	2.3319.013.1	1	pipe union
13	2.1560.013.0	1	gasket 18.2x22
14	0.038.1513.3	1	dipstick
15	0.034.1551.0	1	gasket
17	2.7099.040.0/10	1	pressure switch
18	2.1560.008.0	1	gasket 12.2 x 18
19	0.029.1522.3/10	1	shaft
20	0.029.1520.0	1	pump casing
21	2.1470.004.2	3	lock washer 8
22	0.029.1521.0/10	1	gear
23	2.0112.215.2	3	screw m 8 p.1.25 x 40
24	2.1310.006.2	1	flat washer 10.5x21
25	2.1021.321.1	1	castellated nut
26	2.1690.210.0	1	split pin A2x25
27	2.4419.130.0/10	1	oil filter ☞ 01.00.6
28	0.037.1552.0/10	1	gasket
29	2.1474.010.1	3	spring washer 10
30	2.0112.320.2	2	screw m 10 p.1.5 x 55
31	2.0112.315.2	1	screw m 10 p.1.5 x 40
32	0.038.1536.3/10	1	tube
33	2.3319.002.1	1	pipe fitting
34	2.3350.002.1	1	nosepiece 6, d128
35	2.3360.002.1	1	union nut m 10
36	2.3339.001.0	3	pipe fitting m 10 p.1
37	2.1560.006.0	6	gasket 10.2 x 16
38	0.053.1550.0/10	1	small plate
39	0.053.1551.0	1	small plate
40	0.035.1551.0	2	small plate
42	2.3369.009.1	2	union nut



**Suggest:**

**For more complete manuals. Please go to the home page.**

**<https://www.ebooklibonline.com>**

**If the above button click is invalid. Please download this document first, and then click the above link to download the complete manual.**

**Thank you so much for reading**

Section: ENGINE

**OIL FILTER COMPONENTS**

Fig.	P/n	QTY	Name
------	-----	-----	------

Notes:  
[Condor C]

0	2.4419.130.0/10	1	oil filter
1	2.4419.150.1	1	oil filter element
2	2.4419.130.3	1	gasket
3	2.1530.045.0	1	oil seal 17.86x2.62
4	2.4419.130.2	1	valve
5	0.000.0000.1		cannot be supplied

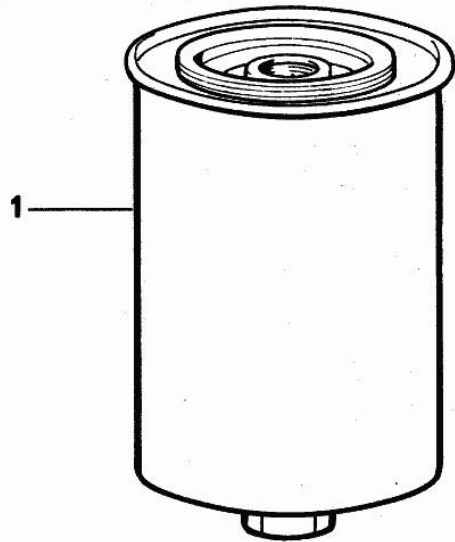
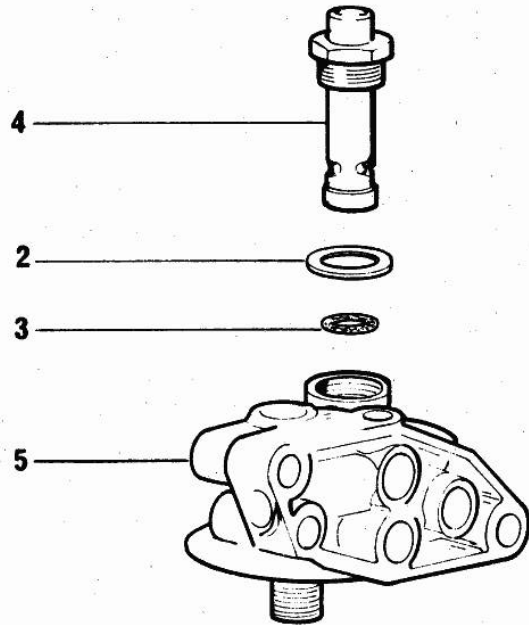

<b>2.4419.130.0/ 10</b>
<b>2.4419.150.0/ 10</b>
<b>2.4419.190.0</b>
<b>2.4419.180.0/10</b>

Section: ENGINE

**FUEL SYSTEM - CONTROLS**

Fig.	P/n	QTY	Name
------	-----	-----	------

**Notes:**

[Condor C]

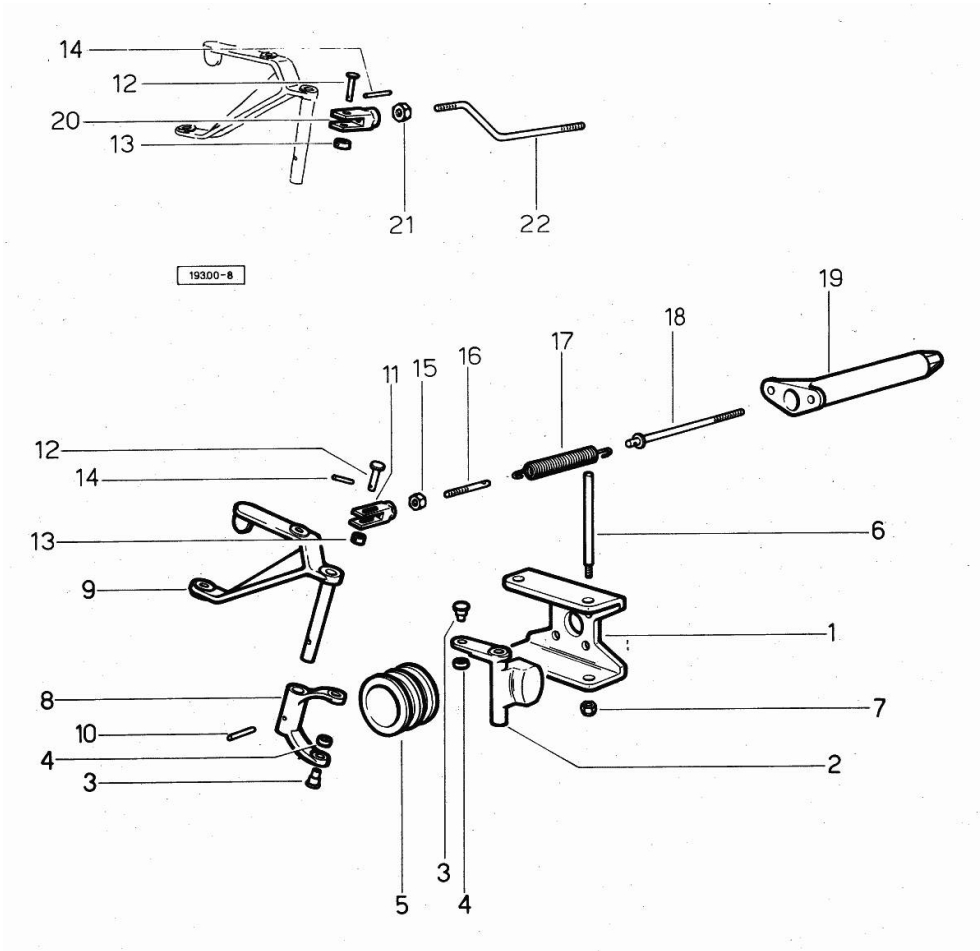

1	0.029.1615.0	1	bracket
2	0.029.1616.0	2	adjust.rocker
3	0.029.1652.0	4	pin
4	0.029.1653.0	4	roller
5	0.029.1618.0	1	sleeve
6	0.029.1617.0	2	pin
7	2.1120.005.2	2	nut m 8 p.1.25
8	0.027.1670.0	1	fork
9	0.320.1621.3	1	lever
10	2.1631.311.0	1	roll pin 3x24
11	2.3519.004.1	1	fork
12	2.1679.018.0	2	pin
13	2.1599.109.0	2	shoulder ring
14	2.1630.006.0	2	roll pin 2x12
15	2.1011.103.2	1	nut m 6 p.1
16	0.029.1627.0	1	stay
17	2.4049.072.1	1	spring
18	0.027.1626.3	1	rod
19	0.029.1624.0	1	spring holder
20	0.000.4699.0	1	fork
21	2.1011.103.2	4	nut m 6 p.1
22	0.027.1674.0	1	rod

**<https://www.ebooklibonline.com>**

Hello dear friend!

Thank you very much for reading.

Enter the link into your browser.

The full manual is available for immediate download.

**<https://www.ebooklibonline.com>**