

Section: ENGINE  
CRANKCASE

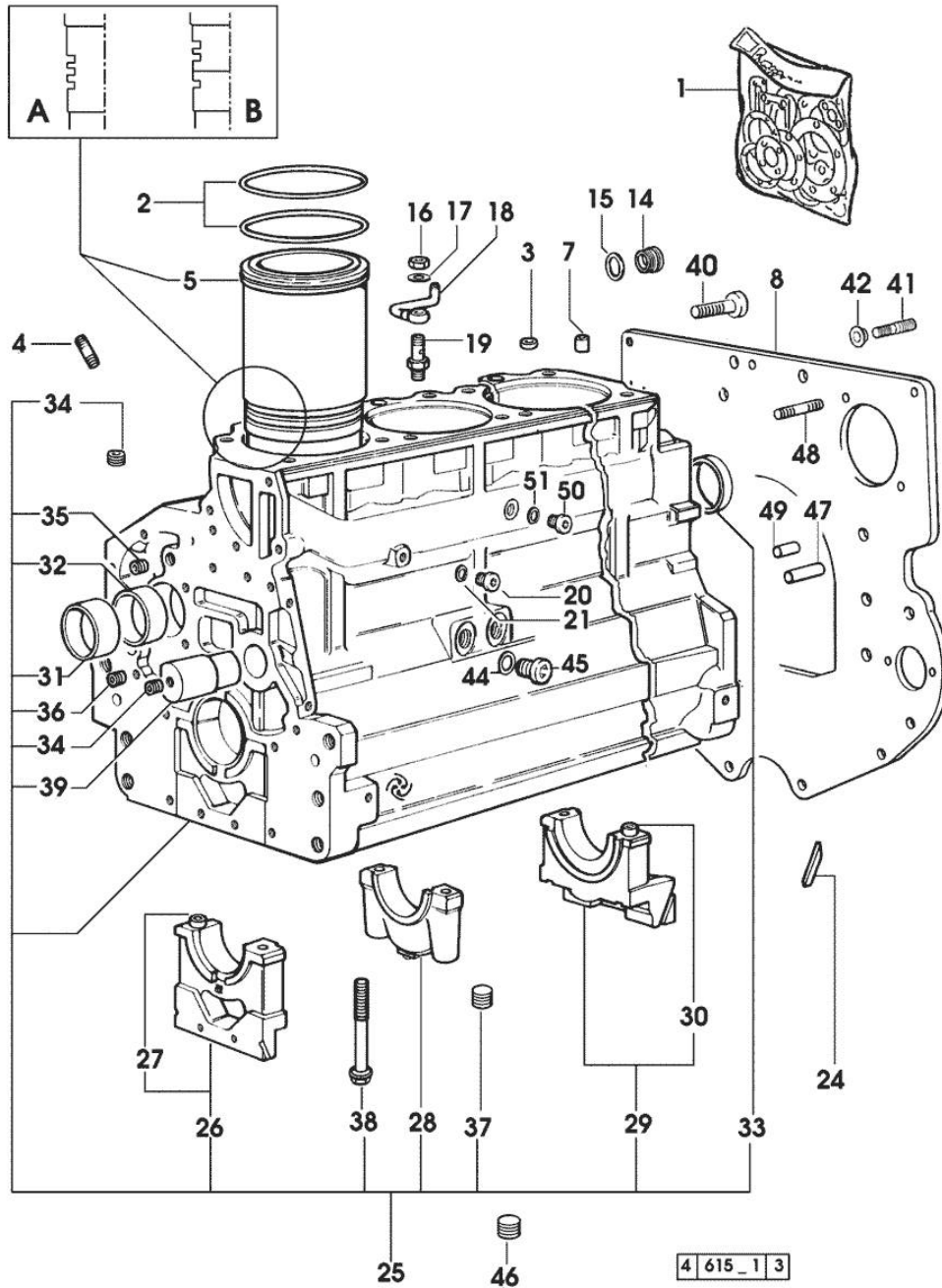

Fig.	P/n	QTY	Name
<b>Notes:</b> [XT-909]			
1	0.090.0050.6	1	gasket set - x XT-908 XT-909 XT-910.4
1	0.335.0050.6	1	gasket set - x XT-910.4 - FOR MODELS WITH MECHANICAL ENGINE GOVERNOR
2	2.1519.096.0/20	12	special oil seal 107.67x1.78 2479 <= x XT-908 2451 <= x XT-909 52259 <= x XT-910.4
2	2.1539.193.0	8	special oil seal 107.62x2.62 => 2480 x XT-908 => 2452 x XT-909 => 52260 x XT-910.4
3	2.1559.188.2	4	bush 11.4 x 14 x16
4	2.0432.003.7	12	stud bolt m 8 p.1.25 / p.1 x 20
5	0.009.7500.0/10	4	engine cylinder = A 1015 <= x XT-908 1018 <= x XT-909 (...) <= x XT-910.4
5	0.011.0183.0/20	4	engine cylinder => 2480 x XT-908 => 2452 x XT-909 => 52260 x XT-910.4
5	0.011.0582.0	4	engine cylinder = B => 1016 - 2479 <= x XT-908 => 1019 - 2451 <= x XT-909 => (...) - 52259 <= x XT-910.4
7	2.1549.154.2	4	bush 4.8x5.8x16
8	0.007.1655.0	1	flange
14	2.3199.405.2	1	plug m 28 p.1.5
15	2.1532.072.0	1	oil seal 26.70x1.78
16	2.1099.108.2	4	special nut m 10 p.1
17	2.1560.006.0	8	gasket 10.2 x 16
18	0.086.1550.2	4	sprayer nozzle
19	0.065.1160.3/20	4	valve
20	2.3199.292.0	1	plug 1/4" gas
21	2.1560.010.0	1	gasket 14.2 x 20
24	0.066.1152.0/10	4	gasket

Section: ENGINE  
**CRANKCASE**

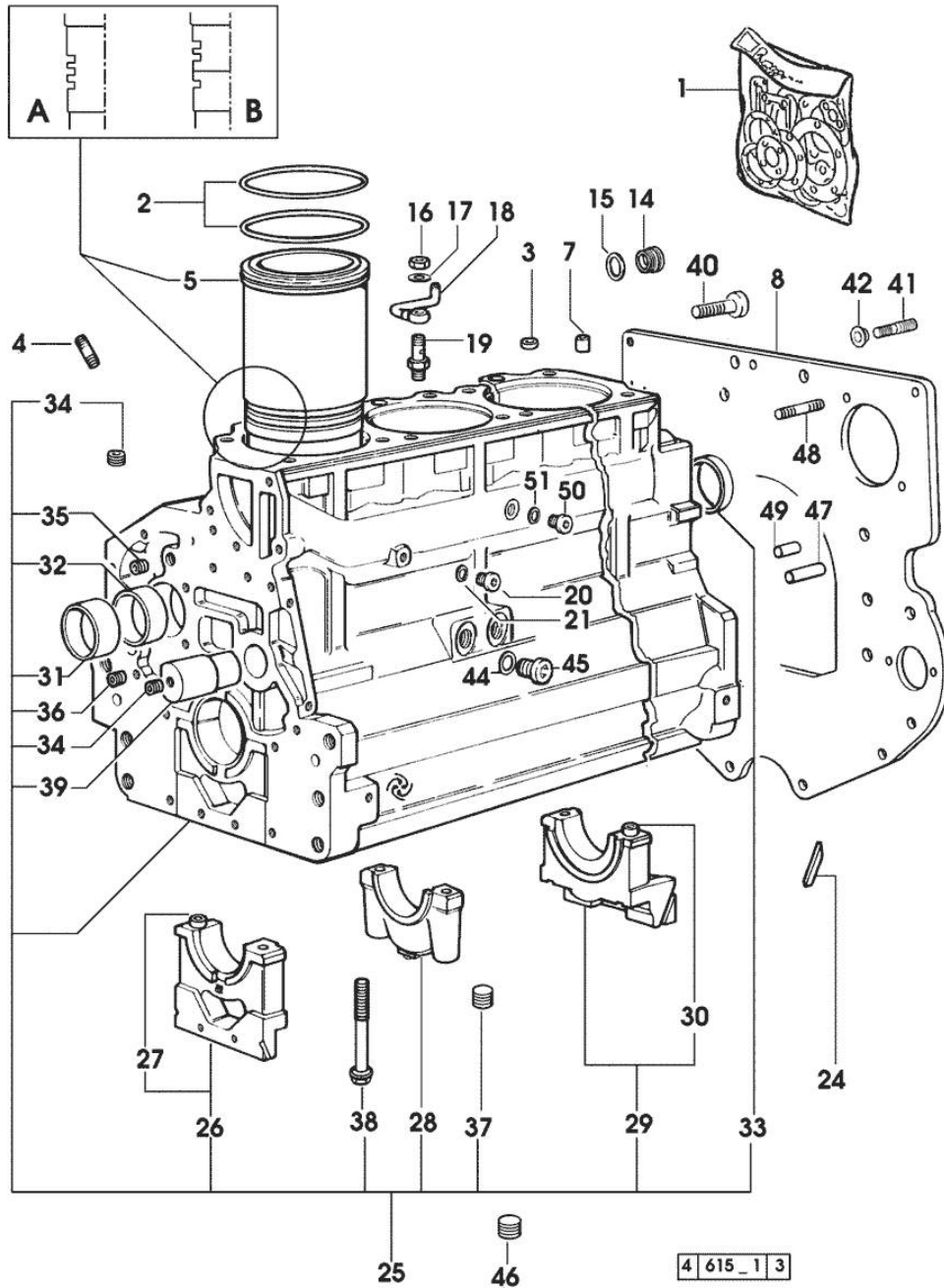

Fig.	P/n	QTY	Name
25	0.082.1110.6/20	1	crankcase 2479 <= x XT-908 2451 <= x XT-909 52259 <= x XT-910.4 - N.4 011.0183.0/10 - N.8 2.1539.193.0 * => 2480 - 3090 <= x XT-908 * => 2452 - 3462 <= x XT-909 * => 52260 - 53046 <= x XT-910.4 - N.16 - 012.2673.0
26	0.065.1112.7	1	support
27	2.1699.165.0	1	bush 12.3x15x16
28	0.065.1114.0/10	3	support
29	0.065.1116.3	1	support
30	2.1699.165.0	1	bush 12.3x15x16
31	0.065.1141.0	1	special bushing 59X55X30
32	0.065.1140.0	4	special bushing 59X55X20
33	2.3179.012.0	1	plug 60
34	2.3130.001.1	11	plug 1/8" gas
35	2.3130.002.1	2	plug 1/4" gas
36	2.3130.003.1	5	plug 3/8" gas
37	2.1324.011.0	1	plug
38	0.065.1117.0	10	screw m 12 x 100
39	0.066.1151.0	1	pin
40	2.0112.511.1	8	screw m 14 p.2 x 30
41	2.0439.250.7	1	stud bolt m 12 / m 10 x 30
42	0.011.9294.0/10	1	bush
44	2.1560.014.0	1	washer 18.2 x 24
45	2.3120.101.0	1	plug m 18 p.1.5
46	2.3130.003.1	1	plug 3/8" gas
47	2.1651.917.0	1	cylindrical plug 12x40
48	2.0432.257.7	1	stud bolt m 12 p.1.75 - 1.25 x 30
49	2.1651.912.0	2	cylindrical plug 12x28
50	2.3120.101.0	1	plug m 18 p.1.5 => 2480 x XT-908 => 2452 x XT-909 => 52260 x XT-910.4
51	2.1560.014.0	1	washer 18.2 x 24

**TIMING CASE**

Fig.	P/n	QTY	Name
------	-----	-----	------

Notes:  
[XT-909]

1	0.007.1262.3/50	1	guard
2	0.007.1271.0/10	1	small column m 8 p.1.25 / L = mm 60
3	0.007.1272.0/10	2	small column m 8 p.1.25 / L = mm 50
5	2.1310.004.2	3	flat washer 8.4x17
7	2.0112.205.2	3	screw m 8 p.1.25 x 16

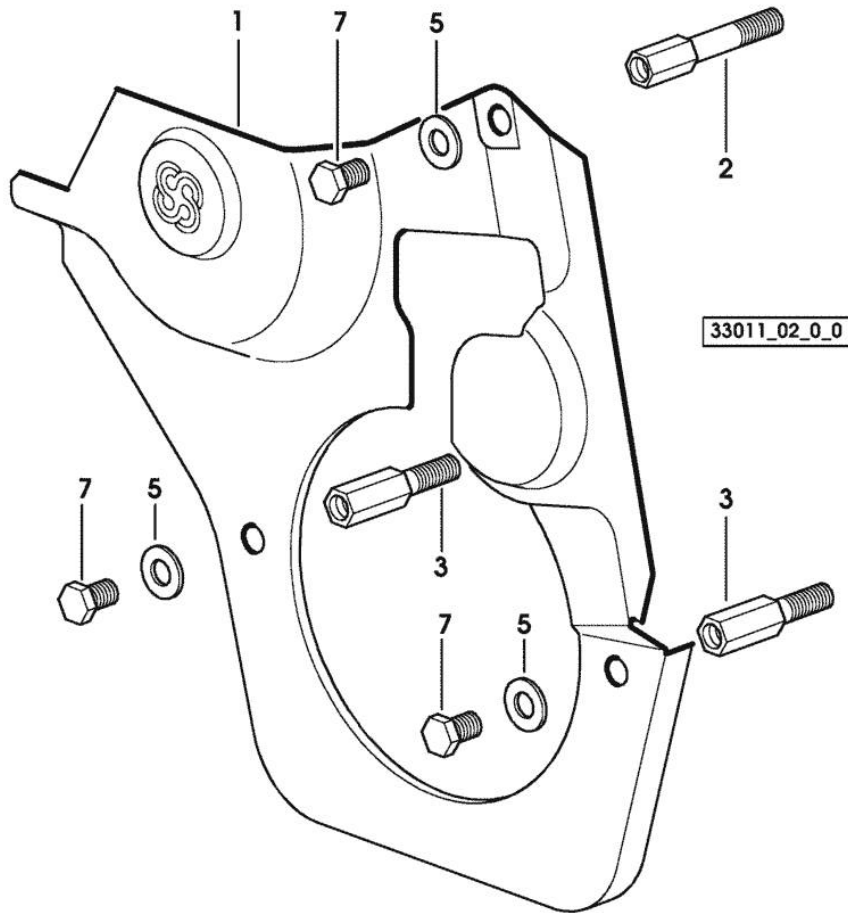

**<https://www.ebooklibonline.com>**

Hello dear friend!

Thank you very much for reading.

Enter the link into your browser.

The full manual is available for immediate download.

**<https://www.ebooklibonline.com>**

Section: ENGINE  
TIMING CASE

Fig.	P/n	QTY	Name
------	-----	-----	------

Notes:  
[XT-909]

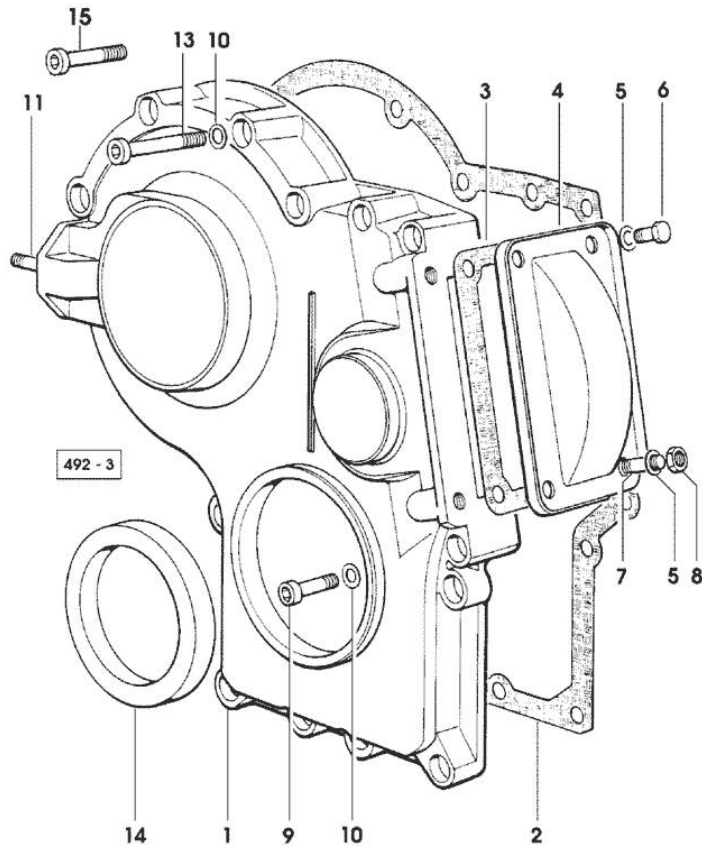

1	0.065.1132.0/60	1	guard
2	0.065.1150.0/30	1	gasket
3	0.065.1152.0	1	gasket
4	0.065.1151.0	1	cover
5	2.1470.004.2	4	lock washer 8
6	2.0112.205.2	2	screw m 8 p.1.25 x 16
7	2.0432.005.7	2	stud bolt m 8 p.1.5 / p.1 x 25
8	2.1011.405.2	2	nut m 8 p.1
9	2.0312.208.2	8	screw m 8 p.1.25 x 25
10	2.1480.014.1	15	washer 8
11	2.0432.003.7	2	stud bolt m 8 p.1.25 / p.1 x 20
13	2.0312.214.2	7	screw m 8 p.1.25 x 40 - x XT-908 XT-909 XT-910.4
14	2.1529.141.0	1	special oil seal
15	2.0312.219.2	4	screw m 8 p.1.25x65 - x XT-910.6

Section: ENGINE

**CRANKSHAFT**

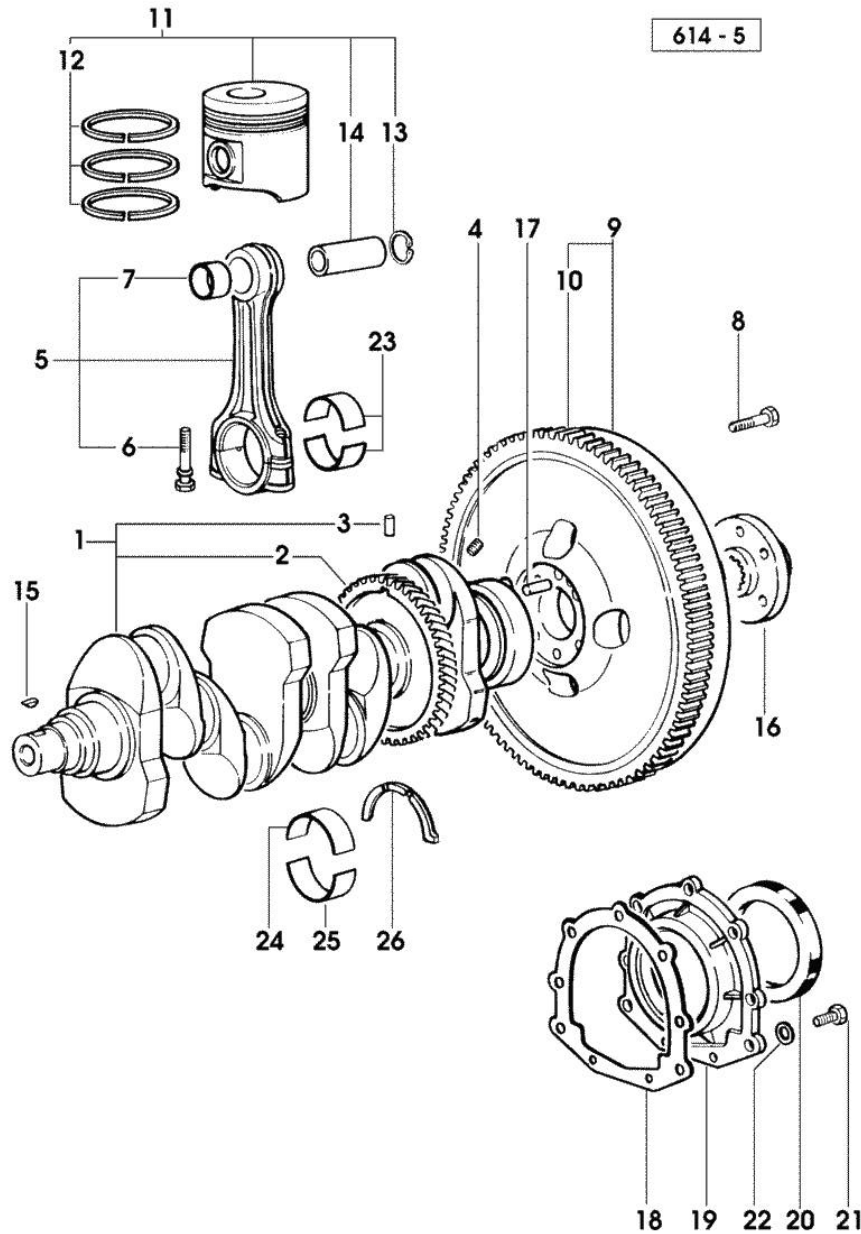

Fig.	P/n	QTY	Name
<b>Notes:</b>			
[XT-909]			
1	0.086.1210.3/30	1	crankshaft
2	0.065.1211.0/10	1	crown wheel
3	2.1630.608.0	1	pin 6x16
4	2.3130.001.1	4	plug 1/8" gas
5	0.078.1220.3/30	4	engine connecting rod
6	2.0399.213.0	8	screw m 12 p.1.25x61.5
7	2.1559.114.0/10	4	special bushing
8	2.0119.174.0/10	6	screw m 12 p.1.25x45 - X FASTDRIVE
8	2.0139.022.2	6	screw m 12 p.1.25x55
9	0.007.1702.3/30	1	flywheel -> 1260 x XT-908 -> 1286 x XT-909 -> 1136 x XT-910.4
9	0.008.4049.3	1	flywheel mm 373 1259 <- x XT-908 1285 <- x XT-909 1135 <- x XT-910.4
9	0.010.7223.3/10	1	flywheel 1260 <- x XT-908 FASTDRIVE 1345 <- x XT-909 FASTDRIVE 1148 <- x XT-910.4 FASTDRIVE
9	0.010.8727.3	1	flywheel -> 1261 x XT-908 FASTDRIVE -> 1346 x XT-909 FASTDRIVE -> 1149 x XT-910.4 FASTDRIVE
10	0.065.1242.0	1	crown wheel Z = 123
11	0.086.0060.6/30	4	complete piston - x XT-908
11	0.087.0060.6/30	4	complete piston - x XT-909 XT-910.4
11	0.379.0060.6	4	complete piston - x XT-908 - EXPORT U.S.A.
11	0.382.0060.6	4	complete piston - x XT-909 XT-910.4 - EXPORT U.S.A.
12	0.081.0090.6/10	4	piston ring set - x XT-909 XT-910.4
12	0.086.0052.6/10	4	piston ring set - x XT-908

Section: ENGINE  
**CRANKSHAFT**

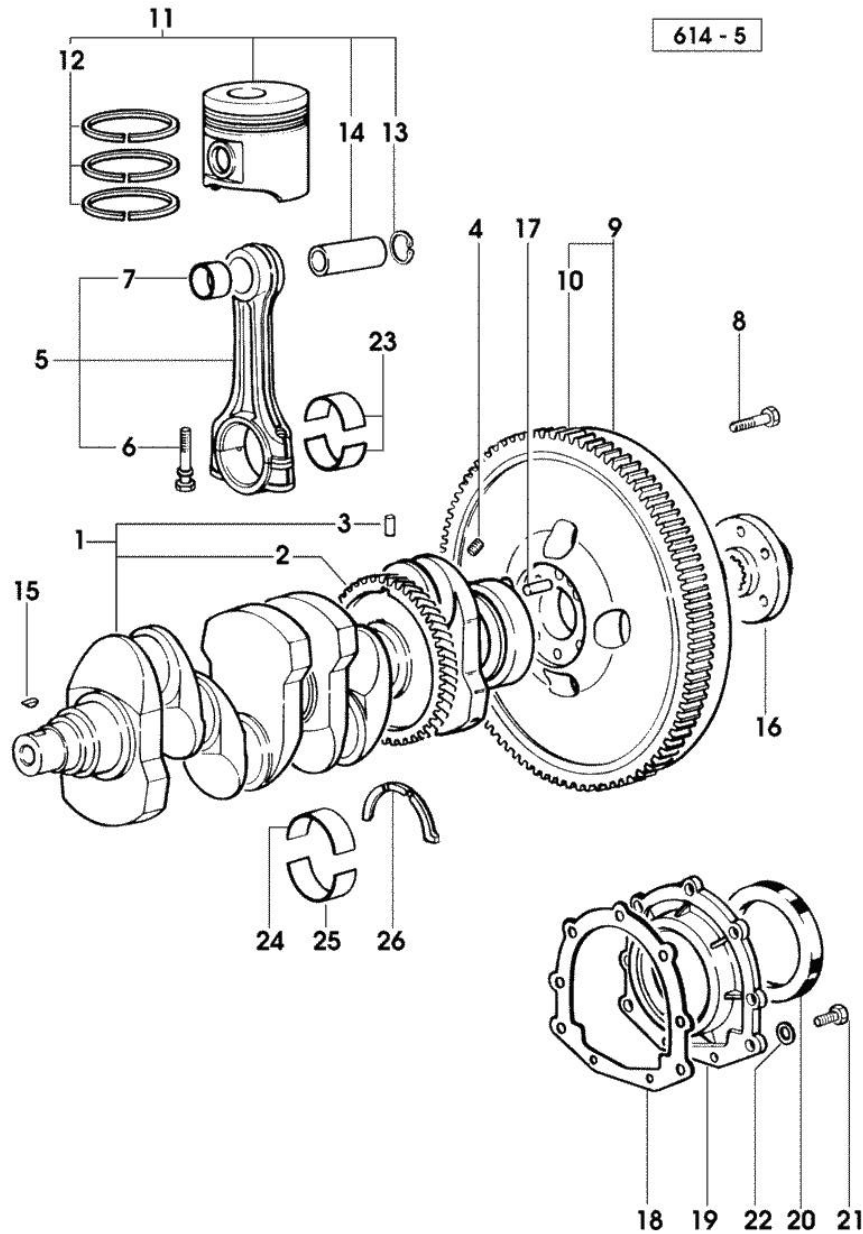

Fig.	P/n	QTY	Name
13	2.1411.014.1	8	circlip 35
14	0.078.1236.0	4	piston pin Ø 18 / Ø 35 / L = mm 86
15	2.1720.006.0	1	key 4x6.5
16	0.008.5543.0	1	flange
17	2.1652.915.0	1	cylindrical plug 12x35
18	0.065.1254.0/20	1	gasket
19	0.007.1711.0/10	1	cover
20	2.1529.073.0	1	special oil seal 110x130x13
21	2.0112.207.2	9	screw m 8 p 1.25 x 20
22	2.1475.202.2	9	spring washer 8.4 x 16
23	0.065.1225.0	8	con.rod half bushing STANDARD - A = 28.75 -> 29.00
23	0.065.1225.7		con.rod half bushing - mm 0.25
23	0.065.1225.8		con.rod half bushing - mm 0.50
24	0.065.1215.0	5	main half bushing STANDARD
24	0.065.1215.7		main half bushing - mm 0.25
24	0.065.1215.8		main half bushing - mm 0.50
25	0.065.1216.0	5	main half bushing
25	0.065.1216.7		main half bushing - mm 0.25
25	0.065.1216.8		main half bushing - mm 0.50
26	0.065.1218.0	4	shim STANDARD
26	0.065.1218.7		shim + mm 0.10
26	0.065.1218.8		shim + mm 0.15

Section: ENGINE

**ENGINE SHAFT - PULLEYS**

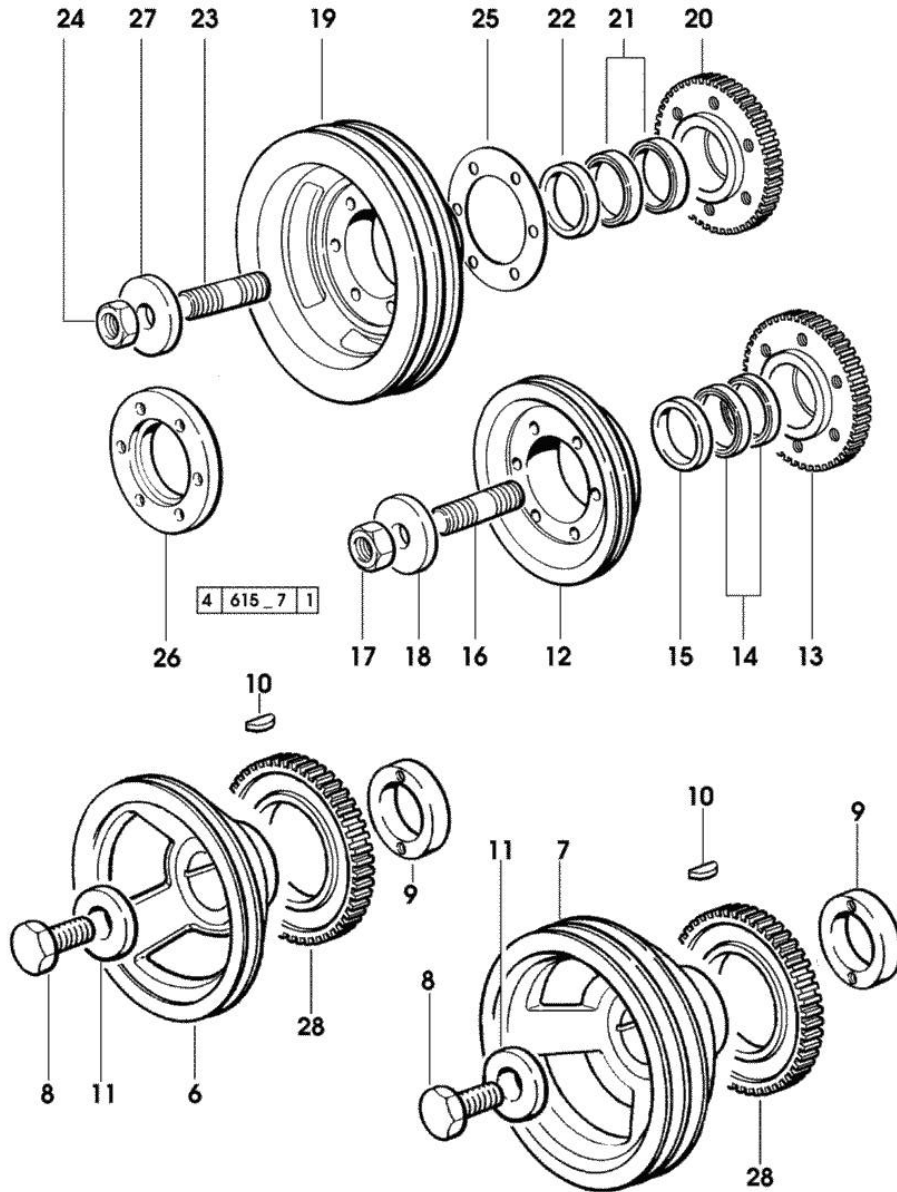

Fig.	P/n	QTY	Name
------	-----	-----	------

Notes:  
[XT-909]

6	0.007.1457.0/20	1	pulley
7	0.007.1458.0/30	1	pulley
			- FOR TRACTORS WITH AIR CONDITIONING
8	2.0399.144.7/10	1	screw m 20 p.1.5x51
9	0.085.1248.0/10	1	hub
10	2.1720.006.0	1	key 4x6.5
11	2.1599.524.7	1	washer 21x60x12
12	0.082.1244.0/10	1	pulley
13	0.011.3515.0/10	1	hub Z = 48
14	0.065.1256.0	2	ring 45x52
15	2.1579.865.0	4	spacer 45.2x51.8x10
16	2.0439.195.7	1	stud bolt m 20 p.1.5x80
17	2.1019.094.7	1	nut m 20 p.1.5
18	2.1599.524.7	1	washer 21x60x12
19	0.082.1250.0/10	1	pulley
			- FOR TRACTORS WITH AIR CONDITIONING
20	0.011.3515.0/10	1	hub Z = 48
21	0.065.1256.0	2	ring 45x52
22	2.1579.865.0	1	spacer 45.2x51.8x10
23	2.0439.195.7	1	stud bolt m 20 p.1.5x80
24	2.1019.094.7	1	nut m 20 p.1.5
25	2.1589.137.0	3	shoulder ring 71x110x1
26	0.089.1253.0/10	1	spacer
27	2.1599.524.7	1	washer 21x60x12
28	0.011.3531.0	1	gear Z = 48

Section: ENGINE  
**COUNTERWEIGHTS**

Fig.	P/n	QTY	Name
------	-----	-----	------

Notes:  
 [XT-909]

1	0.086.1233.3/30	1	mass sx/lh/li
2	2.1559.115.0	2	special bushing 26x30x30
3	2.1652.302.0	1	roll pin 4x6
4	0.000.0000.1		cannot be supplied
5	0.065.1233.3/30	1	mass dx/rh/re
6	2.1410.018.1	1	circlip 45
7	2.1652.302.0	1	roll pin 4x6
8	2.1559.115.0	2	special bushing 26x30x30
9	0.000.0000.1		cannot be supplied
10	2.1589.185.0	4	shoulder ring 26.1x34x1
11	2.1631.717.0	2	roll pin 8 x 40
12	0.086.1231.0/10	1	box
13	2.3130.001.1	4	plug 1/8" gas
14	2.0139.028.2	4	screw m 12
15	2.1579.628.0	3	spacer 16.5x26x0.1
15	2.1589.048.0	1	shoulder ring 16.5x26x0.3
16	2.1579.629.0	4	spacer 12.5x26x0.1
16	2.1589.049.0	2	shoulder ring 12.5x26x0.3
17	2.1579.626.0	2	spacer 13.2x16x11
18	2.1589.139.0	1	shoulder ring mm 0.3
19	2.1589.140.0	3	shoulder ring mm 0.1
20	2.1699.191.0	1	bush 7x10x16
21	0.065.1234.0/10	2	shaft
22	2.3130.001.1	1	plug 1/8" gas

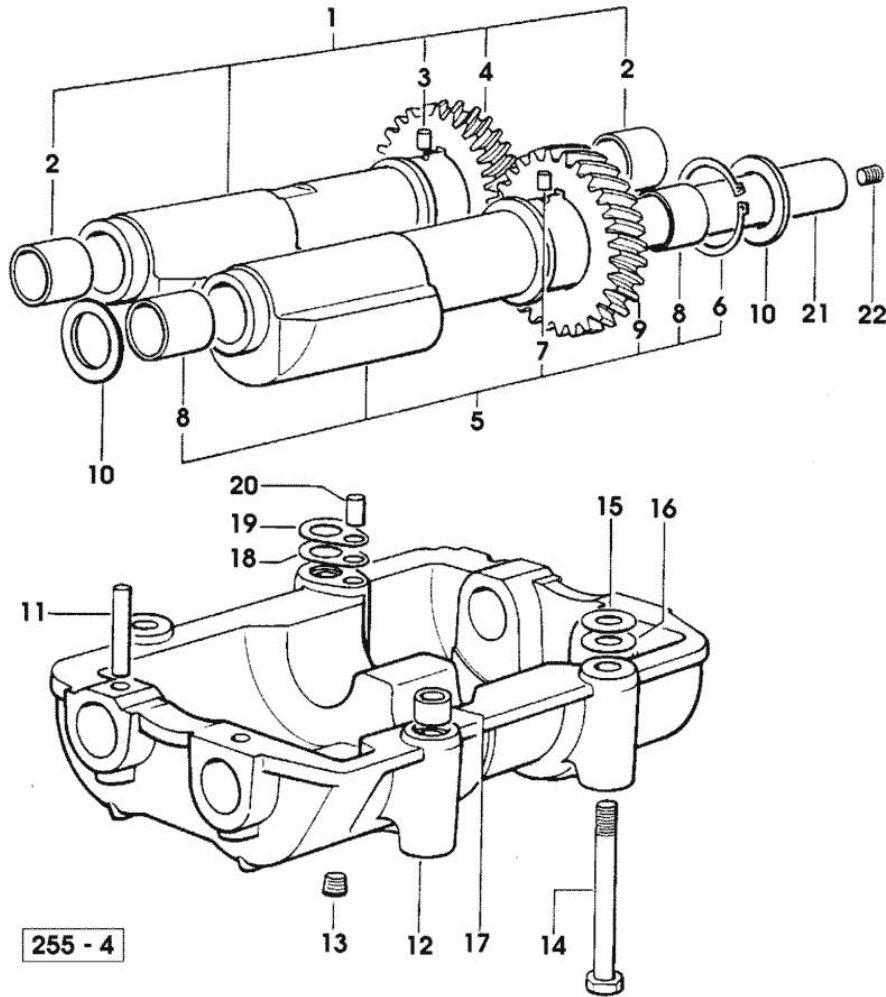

Section: ENGINE

**CAMSHAFT**

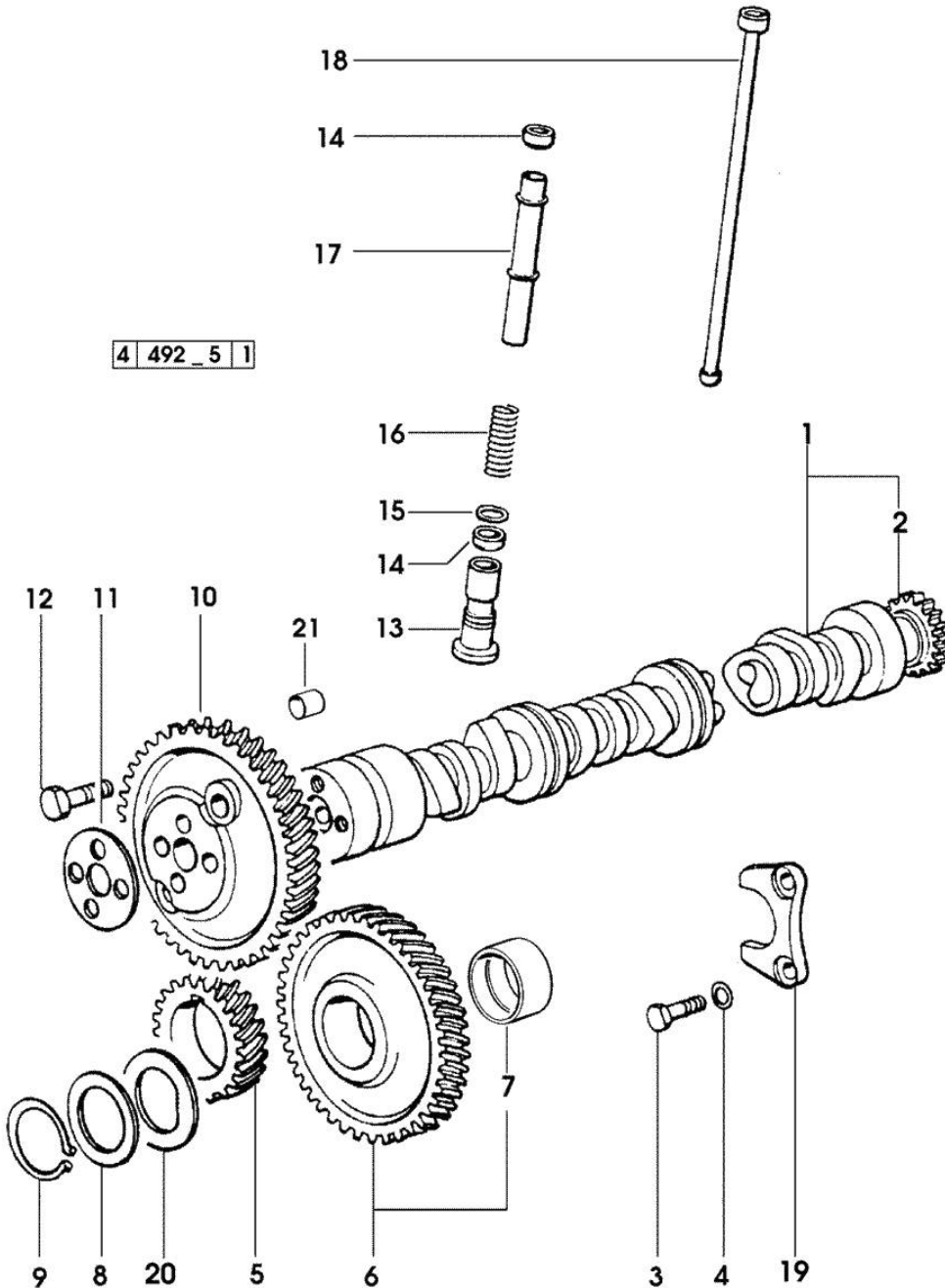

Fig.	P/n	QTY	Name
------	-----	-----	------

Notes:  
[XT-909]

1	0.007.1712.3/10	1	camshaft - EXPORT U.S.A.
1	0.066.1310.3/40	1	camshaft
2	0.065.1324.0/10	1	gear Z = 32
3	2.0312.206.2	2	screw m 8 p 1.25 x 20
4	2.1480.014.1	2	washer 8
5	0.065.1323.0/30	1	gear Z = 29
6	0.007.1177.3/10	1	gear z = 57 - WITH RED IDENTIFICATION STAMP
6	0.007.1178.3/10	1	gear z = 57 - WITH YELLOW IDENTIFICATION STAMP
6	0.007.1179.3/10	1	gear z = 57 - WITH GREEN IDENTIFICATION STAMP
7	2.1559.185.0/10	1	bushing
8	0.065.1352.0	1	shim
9	2.1410.016.1	1	circlip 40
10	0.065.1354.0/20	1	gear z=58
11	0.065.1350.0	1	small disc
12	2.0132.207.2	4	screw m 10 p.1 x 25
13	0.065.1330.0	8	tappets
14	2.1569.114.0/10	16	gasket 14x18.5x8
15	2.1599.437.0	8	shoulder ring
16	2.4019.300.1/10	8	spring 18.5x52x2
17	0.065.1332.0	8	sleeve
18	0.065.1331.2	8	rod
19	0.065.1353.0	1	small plate
20	0.065.1351.0	2	shoulder ring
21	2.1559.398.0	1	bushing 10.5x13x12

Section: ENGINE  
CYLINDER HEAD

Fig.	P/n	QTY	Name
------	-----	-----	------

Notes:  
[XT-909]

1	2.0432.011.7	4	stud bolt m 8 p.1.25 / p.1 x 40
2	2.0432.161.7	4	stud bolt m 10 p.1.5 / p.1.25 x 40
4	0.010.6016.0	4	inlet valve mm 43.63 / Ø mm 9 - x XT-908
4	0.010.6017.0	4	inlet valve mm 43.63 / Ø mm 9 - x XT-909 XT-910.4 -> (...) = B
4	0.081.1420.0	4	inlet valve Ø mm 9 - x XT-909 XT-910.4 (...) <= A
5	0.010.6022.0	4	exhaust valve mm 39.1 / Ø mm 9 - x XT-909 XT-910.4 -> (...) = B
5	0.066.1421.0	4	exhaust valve - x XT-908 - x XT-909 XT-910.4 (...) <= A
6	0.074.1423.0	16	conical valve cotter
7	0.066.1425.0	8	cup
8	2.4019.287.0	8	spring
9	0.012.2673.0	16	screw m 14 p.2x141 => 3091 x XT-908 => 3463 x XT-909 => 53047 x XT-910.4
9	0.066.1443.0/10	16	screw 3090 <= x XT-908 3462 <= x XT-909 53046 <= x XT-910.4
10	0.066.1432.0	8	rocker arm
11	0.066.1430.0/10	4	support
12	2.1599.432.0	8	shoulder ring
13	2.1410.055.1	8	circlip 19
14	2.0432.163.7	8	stud bolt m 10 p.1.5 / p.1.25 x 45
15	2.1011.421.2	8	nut m 10 p.1.25
16	0.021.1434.0	8	screw
17	2.1011.405.2	8	nut m 8 p.1
18	0.007.1139.0/10	4	small cap
19	0.065.1450.0/30	1	tappet gasket
20	2.0399.130.2/10	4	screw m 8x36x44
21	2.1569.170.0/10	4	gasket 8.2 x 14
22	0.078.1451.0/40	4	head gasket -A-
22	0.078.1452.0/30	4	head gasket -B-
22	0.078.1453.0/40	4	head gasket -C-
24	2.0432.005.7	4	stud bolt m 8 p.1.5 / p.1 x 25
25	0.007.1360.3/60	4	head

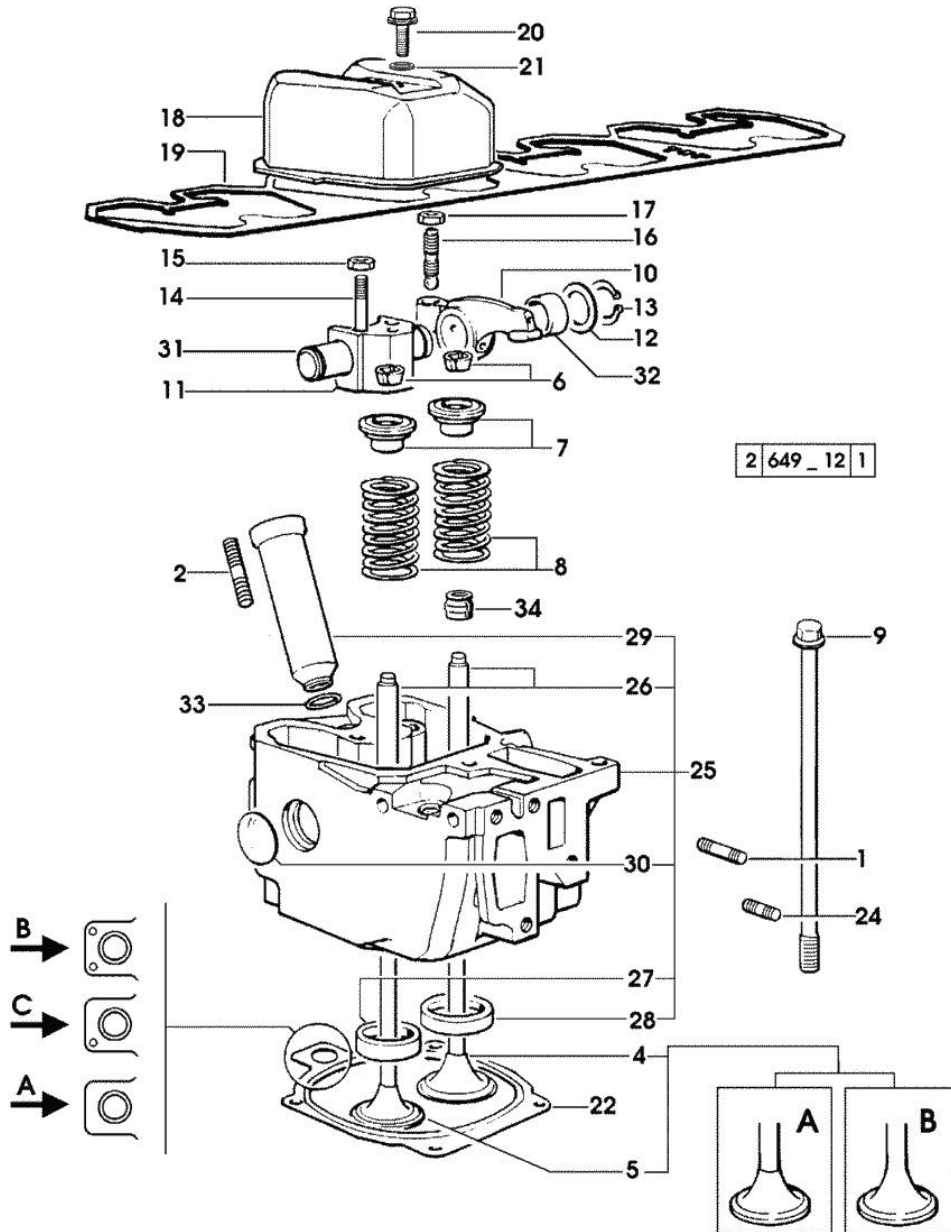

Section: ENGINE  
CYLINDER HEAD

Fig.	P/n	QTY	Name
25	0.012.2693.3/10	4	- x XT-909 XT-910.4 -> (...) = B engine head - x XT-908
26	0.007.1779.0/10	8	- x XT-909 XT-910.4 (...) <- = A valve guide
27	0.066.1427.0	4	valve seat
28	0.078.1426.0	4	valve seat
29	0.010.6041.0	4	bush
30	2.3170.012.1	8	expansion plug 30
31	0.066.1431.0	4	pin
32	2.1559.021.0/40	8	bushing 15x19x22
33	2.1530.051.0	4	oil seal 20.22x3.53
34	2.1519.117.0	8	special oil seal

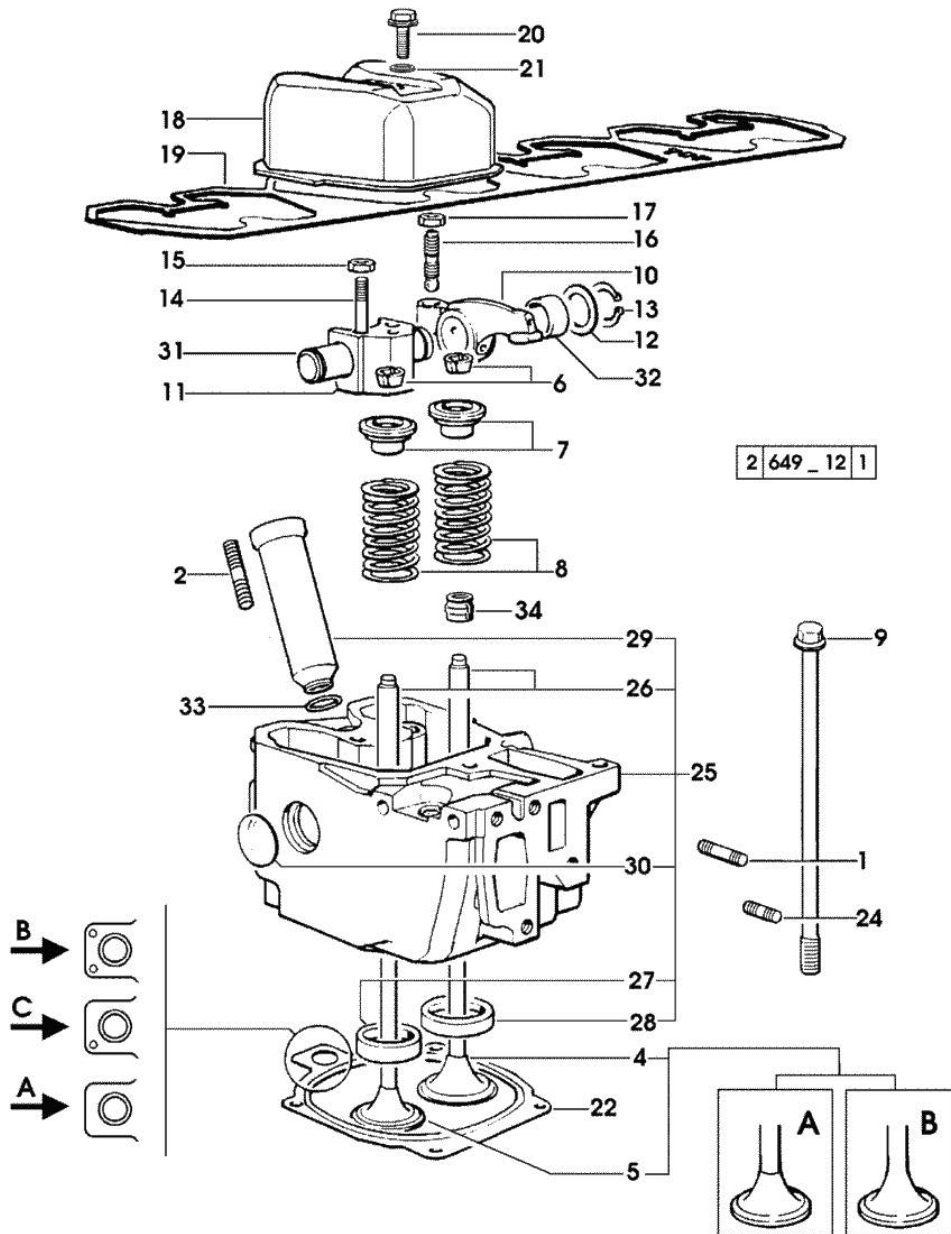

Section: ENGINE  
LUBRICATION

Fig.	P/n	QTY	Name
------	-----	-----	------

Notes:  
[XT-909]

1	0.007.1277.0/40	1	oil sump
2	0.065.1550.0/10	1	gasket
3	2.3199.001.2	2	plug 1/2" gas
4	2.0112.239.2	2	screw m 8 p.1.25 x 150
5	2.0112.226.2	4	screw m 8 p.1.25 x 85
6	2.0112.215.2	17	screw m 8 p.1.25 x 40
7	2.1470.004.2	26	lock washer 8
8	0.065.1531.3/20	1	tube
9	2.0112.209.2	1	screw m 8 p 1.25 x 25
10	2.1011.105.2	1	nut m 8 p.1.25
11	2.1470.004.2	2	lock washer 8
12	0.065.1538.0	1	flange
13	2.1539.040.0	1	special oil seal 21.82 x 3.53
18	0.086.1513.2/20	1	dipstick
19	2.1539.065.0	2	special oil seal 8.73 x 1.78
20	2.0112.235.2	3	screw m 8 p.1.25 x 130
23	2.4419.340.0	1	oil filter element
24	2.3339.307.0	1	pipe fitting m 22 p.1.5-3/4"
26	2.1560.054.0	2	gasket 21 x 26
29	2.1579.766.2	1	spacer 8.5x16x10

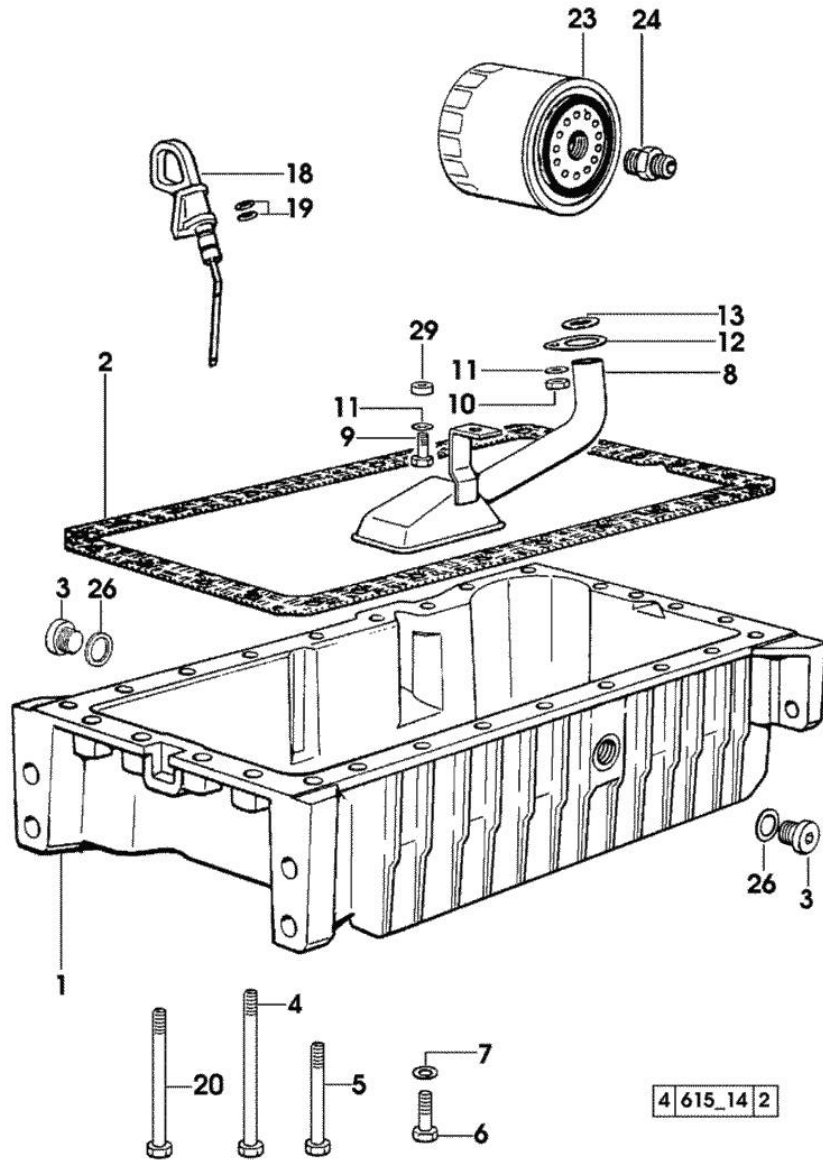

Section: ENGINE  
**LUBRICATION**

Fig.	P/n	QTY	Name
------	-----	-----	------

Notes:  
 [XT-909]

1	0.078.1554.3	1	box
2	0.066.1750.0	1	tube
3	2.1560.014.0	1	washer 18.2 x 24
4	2.3120.101.0	1	plug m 18 p.1.5
5	0.078.1557.0/10	2	gasket
6	0.078.1556.0/10	1	gasket
7	0.078.1555.0/10	1	plate
8	2.1310.004.2	8	flat washer 8.4x17
9	2.0112.205.2	8	screw m 8 p.1.25 x 16
10	2.1480.014.1	4	washer 8
11	2.0312.217.2	2	screw m 8 p.1.25x55
12	2.0312.220.2	2	screw m 8 p.1.25x70
13	2.1539.048.0	1	special oil seal 20.35x1.78
14	2.1539.050.0	1	special oil seal 69.57x1.78
15	0.078.1540.3	1	radiator

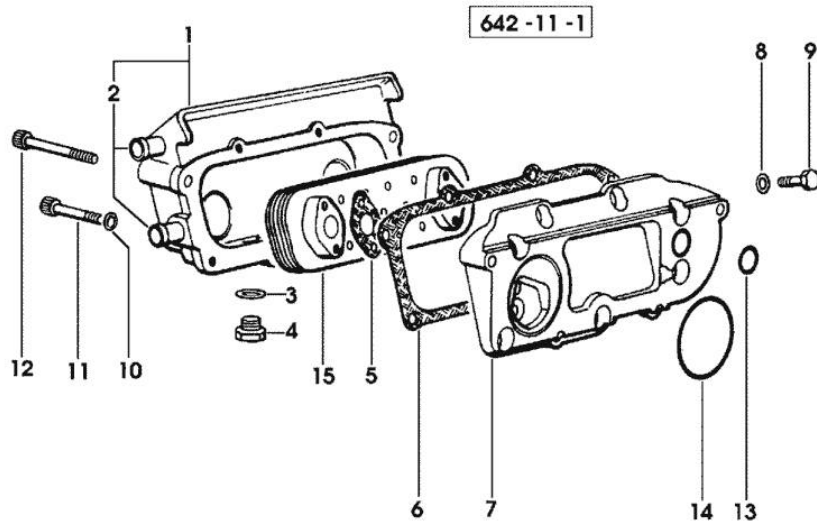



**Suggest:**

**For more complete manuals. Please go to the home page.**

**<https://www.ebooklibonline.com>**

**If the above button click is invalid. Please download this document first, and then click the above link to download the complete manual.**

**Thank you so much for reading**



Section: ENGINE  
LUBRICATION

Fig.	P/n	QTY	Name
------	-----	-----	------

Notes:  
[XT-909]

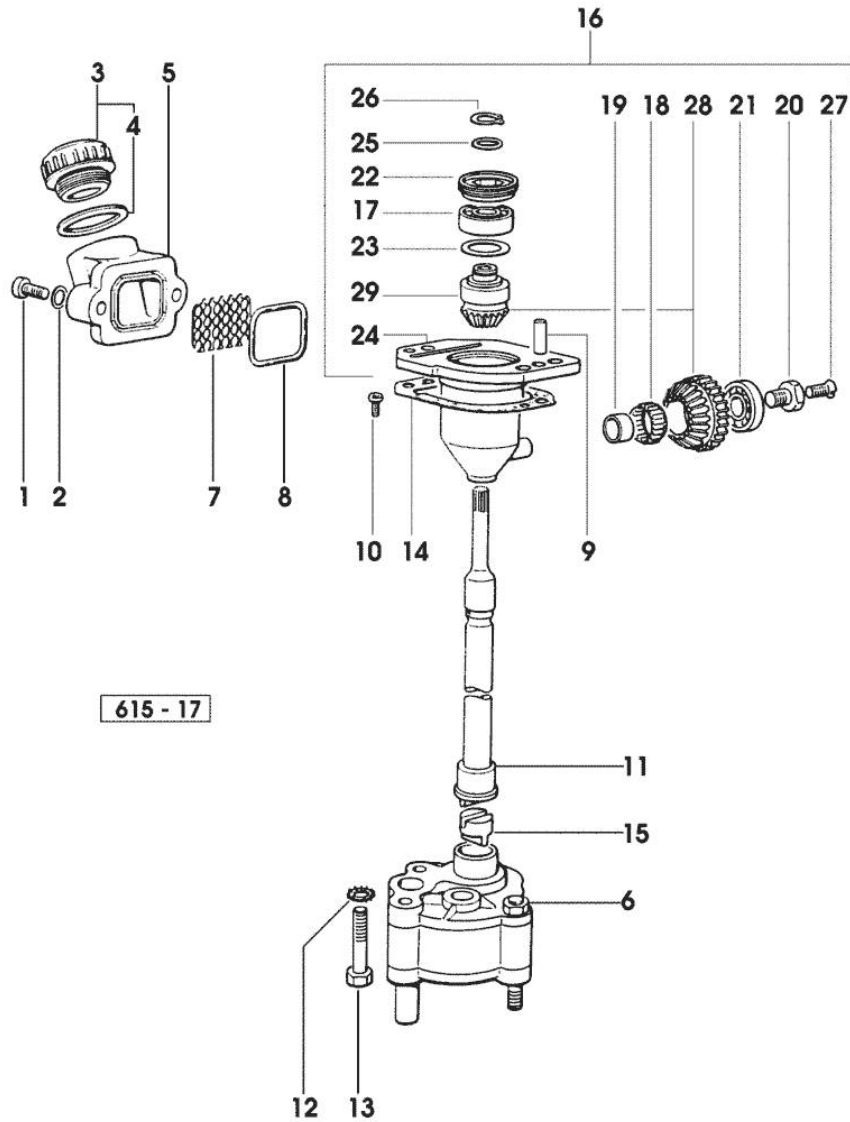

1	2.0312.206.2	2	screw m 8 p 1.25 x 20
2	2.1480.014.1	2	washer 8
3	0.041.1135.4	1	plug 1" gas
4	2.1569.072.0	1	gasket 32 x 39.5 x 2
5	0.065.1565.0/10	1	pipe union
6	0.010.5441.4/10	1	oil pump
7	0.065.1567.0/10	1	filter
8	2.1539.042.0	1	special oil seal 47.35x1.78
9	2.1651.711.0	2	pin 8 x 14
10	2.0169.005.2	2	screw m 6 p.1 x 12
11	0.065.1569.0/40	1	shaft
12	2.1470.006.2	2	lock washer 10
13	2.0112.324.2	2	screw m 10 p.1.5x75
14	0.065.1560.0/20	2	gasket
15	0.065.1562.0/10	1	joint
16	0.075.1551.4/20	1	support
17	2.2020.001.0	1	ball bearing 15 x 32 x 8.00
18	2.2725.016.0	1	roller cage 15 x 21 x 12
19	2.2680.020.0	1	ring 12 x 15 x 12
20	2.0399.128.2/10	1	screw m 8 p.1 x 8
21	2.2030.002.0	1	ball bearing 12 x 28 x 8
22	2.1219.025.2/10	1	ring nut m 36 p.1.5
23	2.1589.148.0	1	shoulder ring 28.2 x 31.8 x 0.5
23	2.1589.150.0	2	shoulder ring 28.2 x 31.8 x 0.1
23	2.1589.151.0	2	shoulder ring 28.2 x 31.8 x 0.15
24	0.075.1551.3/30	1	support
25	2.1589.146.0	2	shoulder ring 15.2 x 19 x 0.15
25	2.1589.147.0	2	shoulder ring 15.2 x 19 x 0.10
25	2.1589.153.0	1	shoulder ring 15.2 x 19 x 1.00
26	2.1410.057.1	1	circlip 15
27	2.0342.007.2	1	screw m 4 p.0.7x25
28	0.065.1558.6/10	1	bevel drive
29	0.065.1559.0	1	bush

**<https://www.ebooklibonline.com>**

Hello dear friend!

Thank you very much for reading.

Enter the link into your browser.

The full manual is available for immediate download.

**<https://www.ebooklibonline.com>**