

CRANKCASE

Fig.	P/n	QTY	Name
------	-----	-----	------

Notes:
[XT-85]

3	2.3199.312.2/20	1	plug m 35x1.5x9.5
5	2.0439.273.7	8	stud bolt m 8
6	2.1559.188.2	4	bush 11.4 x 14 x16
7	2.1539.259.0	8	special oil seal 107.62x2.62
8	2.1560.010.0	1	gasket 14.2 x 20
9	2.3199.292.0	1	plug 1/4" gas
11	0.066.1152.0/10	4	gasket
13	2.1549.154.2	4	bush 4.8x5.8x16
14	0.015.2988.4/10	1	crankcase
14.1	2.3130.001.1	10	plug 1/8" gas
14.2	2.3130.002.1	2	plug 1/4" gas
14.3	2.3130.003.1	6	plug 3/8" gas
14.4.1.1.1	0.065.1112.7/10	1	support
14.4.1.2	2.1699.165.0	1	bush 12.3x15x16
14.4.2	0.065.1114.0/10	3	support
14.4.3	0.065.1116.3	1	support
14.4.3.2	2.1699.165.0	1	bush 12.3x15x16
14.4.5	0.065.1117.0	10	screw m 12 x 100
14.5	2.3179.012.0	1	plug 60
14.6	0.065.1140.0	4	special bushing 59X55X20
14.7	0.065.1141.0	1	special bushing 59X55X30
14.8	0.014.1340.0/10	1	pin mm 85
25	0.013.4946.0/10	1	sprayer nozzle
26	2.3120.101.0	1	plug m 18 p.1.5
28	2.1560.014.0	1	washer 18.2 x 24

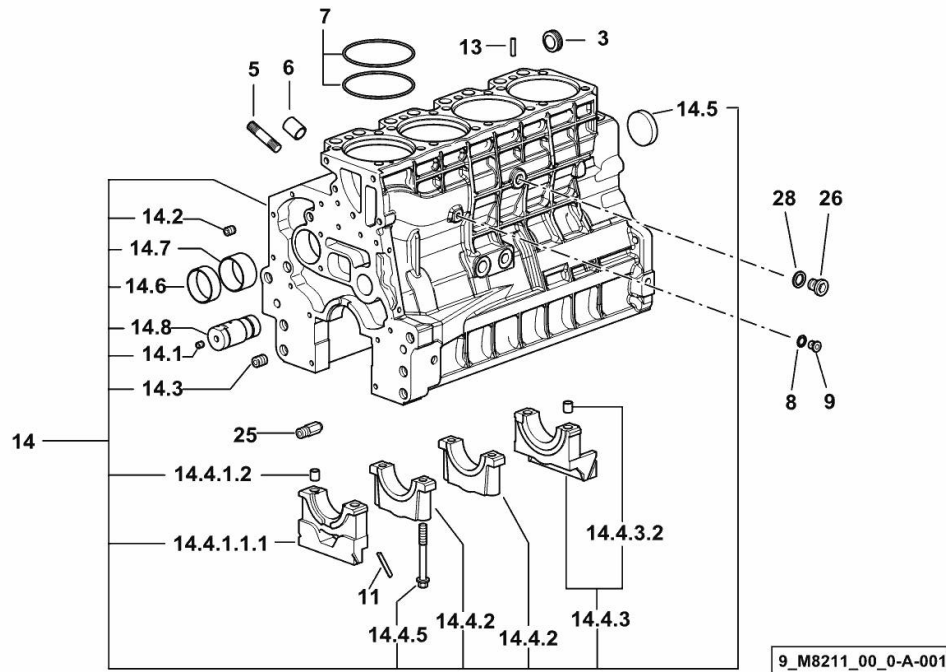

MONOBLOC ENGINE-GEARBOX CONNECTING FLANGE

Fig.	P/n	QTY	Name
------	-----	-----	------

Notes:
[XT-85]

6	2.0439.250.7	1	stud bolt m 12 / m 10 x 30
7	0.011.9294.0/10	1	bush
25	0.007.1655.0	1	flange
26	2.0112.511.2	8	screw m 14 p.2 x 30
27	2.1651.912.0	2	cylindrical plug 12x28
28	2.1651.917.0	1	cylindrical plug 12x40
29	2.0432.257.7	1	stud bolt m 12 p.1.75 - 1.25 x 30

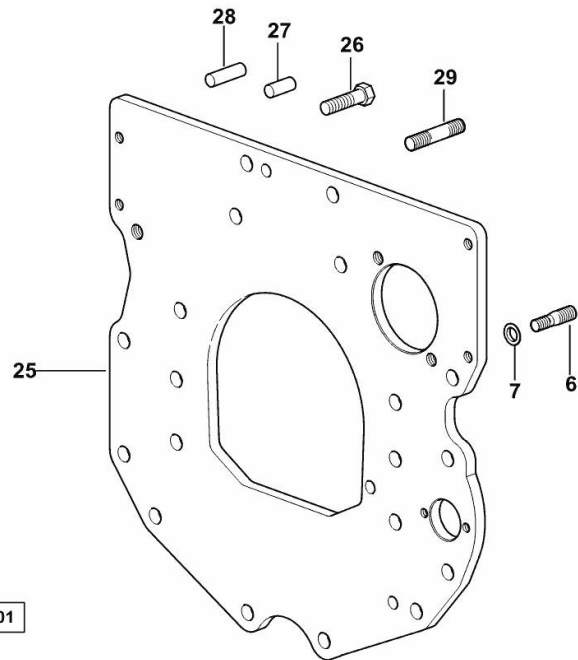

9_32111_01_0-A-001

ENGINE OIL AND TURBO PRESSURE SWITCH UNION

Fig.	P/n	QTY	Name
------	-----	-----	------

Notes:
[XT-85]

8	2.3339.673.0/10	1	pipe fitting
11	2.3110.403.1	1	plug m 14 p.1.5x12
12	2.1560.010.0	1	gasket 14.2 x 20
13	2.1019.129.2/10	1	nut m 18 p.1.5x12
14	2.1533.038.0	1	oil seal 15.45x2.62

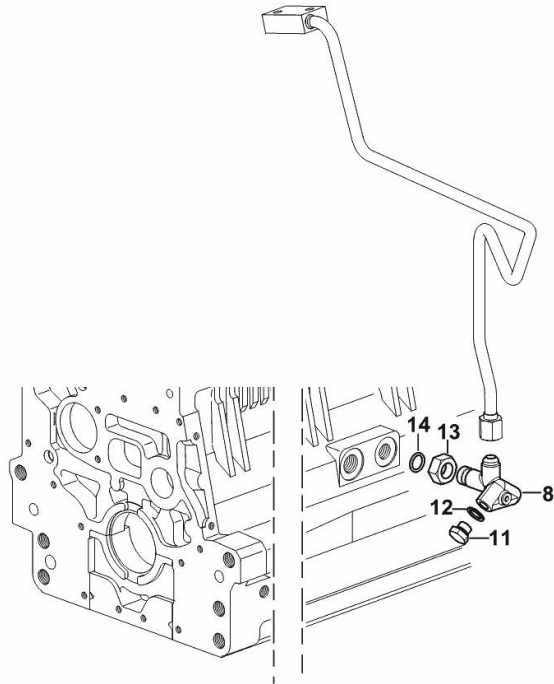

9_32615_05_0-B-001

<https://www.ebooklibonline.com>

Hello dear friend!

Thank you very much for reading.

Enter the link into your browser.

The full manual is available for immediate download.

<https://www.ebooklibonline.com>

PLUG

Fig.	P/n	QTY	Name
------	-----	-----	------

Notes:
[XT-85]

1	2.3130.003.1	1	plug 3/8" gas
---	--------------	---	---------------

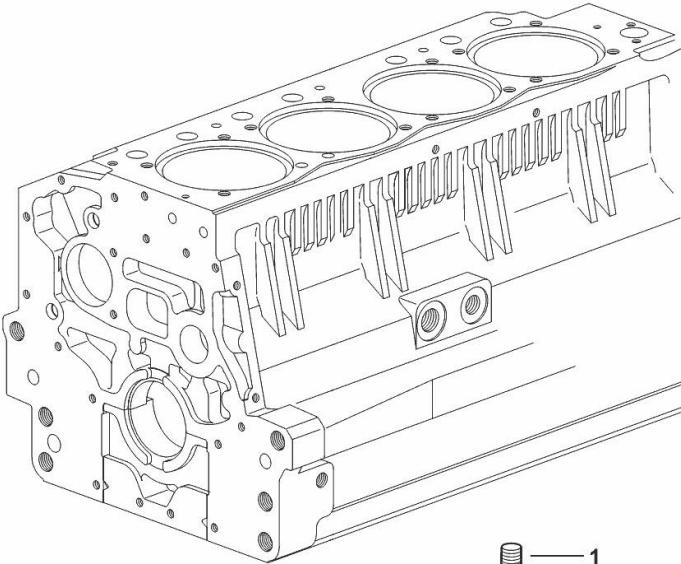

1

9_34311_06_0-A-001

CRANKSHAFT PULLEY

Fig.	P/n	QTY	Name
------	-----	-----	------

Notes:
[XT-85]

3	0.007.1457.0/30	1	pulley
5	0.085.1248.0/20	1	hub
6	2.0399.144.7/10	1	screw m 20 p.1.5x51
8	2.1720.006.0	1	key 4x6.5

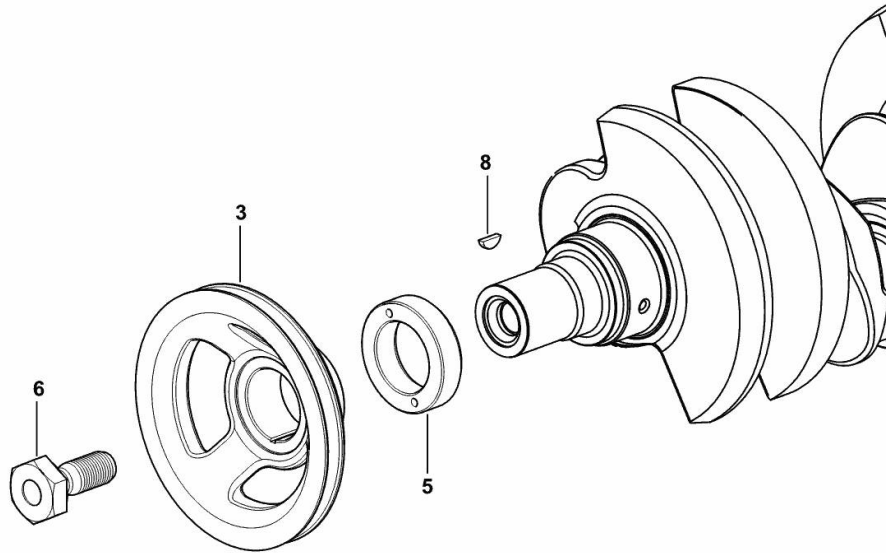

9_33312_02_0-A-001

CRANKSHAFT PULLEY

Fig.	P/n	QTY	Name
------	-----	-----	------

Notes:

- FOR TRACTORS WITH AIR CONDITIONING [XT-85]

3	0.007.1458.0/40	1	pulley
5	0.085.1248.0/20	1	hub
6	2.0399.144.7/10	1	screw m 20 p.1.5x51
8	2.1720.006.0	1	key 4x6.5

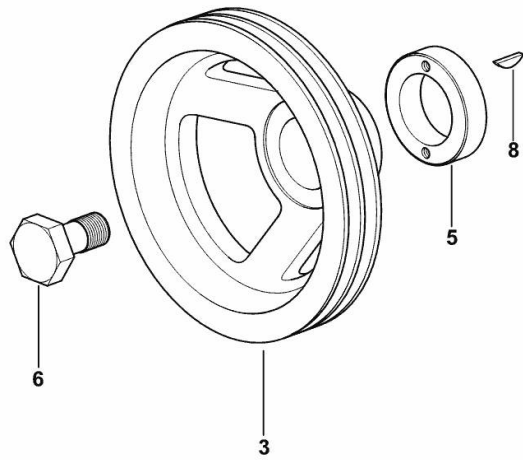

9_34512_06_0-A-001

PULSE WHEEL

Fig.	P/n	QTY	Name
------	-----	-----	------

Notes:
[XT-85]

1	0.011.3531.0	1	gear Z = 48
---	--------------	---	-------------

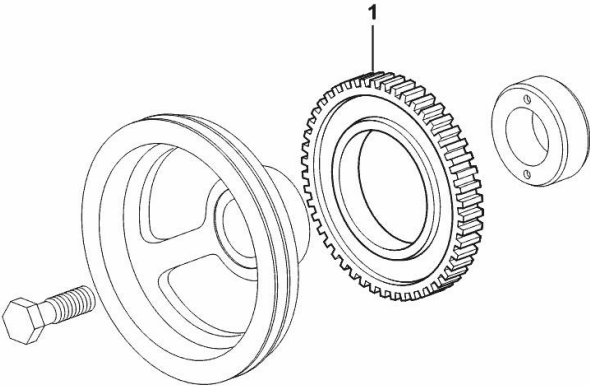

9_36812_05_0-A-001

ENGINE CRANKSHAFT PULLEY WITH RING-FEEDER RINGS

Fig.	P/n	QTY	Name
------	-----	-----	------

Notes:

- FOR MODELS EQUIPPED WITH FRONT P.T.O. [XT-85]

1	0.082.1244.0/10	1	pulley
2	0.011.3515.0/20	1	hub Z = 48
3	0.065.1256.0	2	ring 45x52
4	2.1579.865.0	1	spacer 45.2x51.8x10
5	2.0439.195.7	1	stud bolt m 20 p.1.5x80
6	2.1019.094.7	1	nut m 20 p.1.5

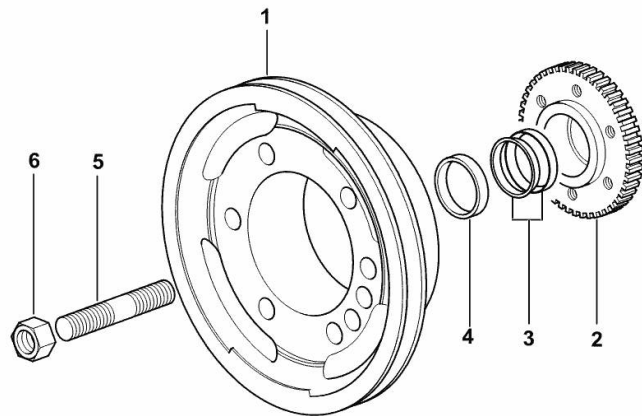

9_34512_07_0-A-001

ENGINE CRANKSHAFT PULLEY WITH RING-FEEDER RINGS

Fig.	P/n	QTY	Name
------	-----	-----	------

Notes:

- FOR TYPES WITH AIR CONDITIONING AND FRONT PTO [XT-85]

1	0.082.1250.0/10	1	pulley
2	0.011.3515.0/20	1	hub Z = 48
3	0.065.1256.0	2	ring 45x52
4	2.1579.865.0	1	spacer 45.2x51.8x10
5	2.0439.195.7	1	stud bolt m 20 p.1.5x80
6	2.1019.094.7	1	nut m 20 p.1.5
7	2.1589.137.0	3	shoulder ring 71x110x1
8	0.089.1253.0/10	1	spacer

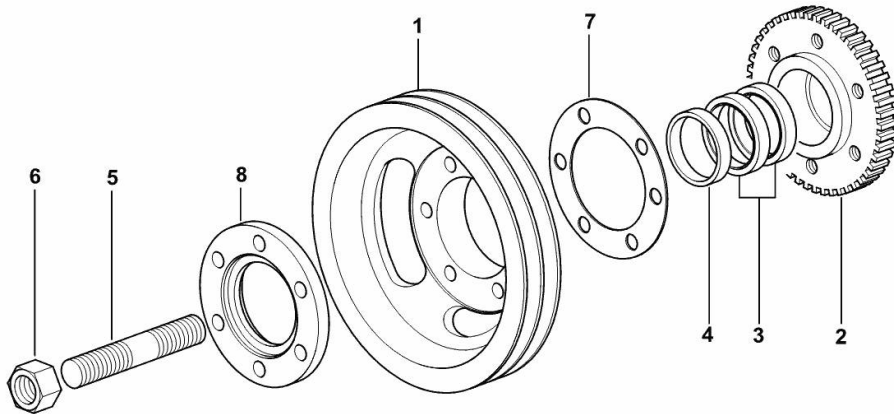

9_34512_08_0-A-001

COOLANT PUMP AND ALTERNATOR DRIVEBELT

Fig.	P/n	QTY	Name
------	-----	-----	------

Notes:

- FOR MODELS WITH PLATFORM [XT-85] - FOR TYPES WITH CAB WITHOUT AIR CONDITIONING
 [XT-85] 1009 <-

1	2.4119.193.0	1	vee belt AV 10 x 1254 mm
---	--------------	---	--------------------------

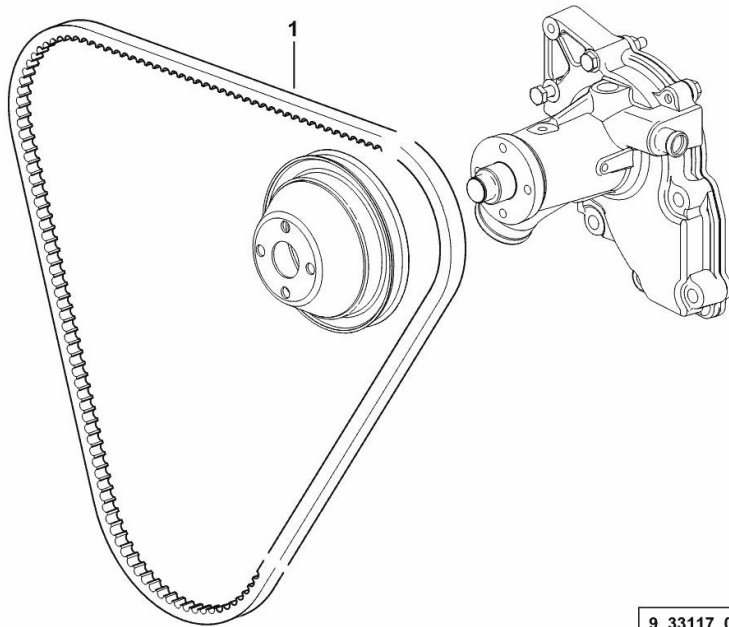

9_33117_09_0-A-001

COOLANT PUMP AND ALTERNATOR DRIVEBELT

Fig.	P/n	QTY	Name
------	-----	-----	------

Notes:

- FOR TYPES WITH CAB WITHOUT AIR CONDITIONING [XT-85] -> 1010

1	2.4119.194.0	1	belt AV 10x1290 mm
---	--------------	---	--------------------

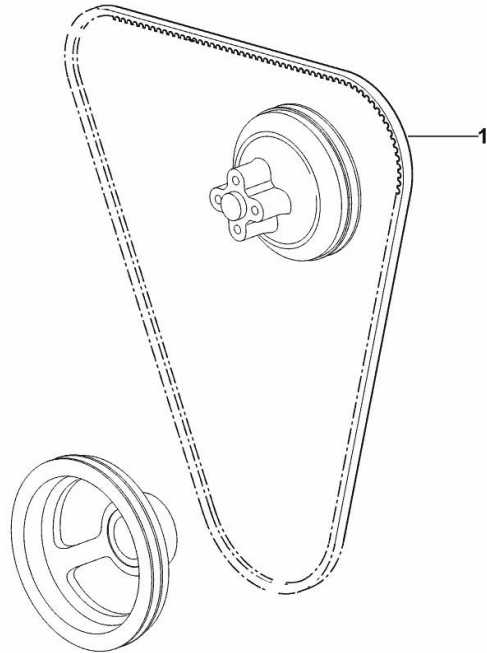

9_M5117_09_0-A-001

COOLANT PUMP AND ALTERNATOR DRIVEBELT

Fig.	P/n	QTY	Name
------	-----	-----	------

Notes:

- FOR TRACTORS WITH AIR CONDITIONING [XT-85]

1	2.4119.138.0	2	belt AV 12.7x1380 mm
2	2.4119.134.0	1	belt AV 10x794 mm

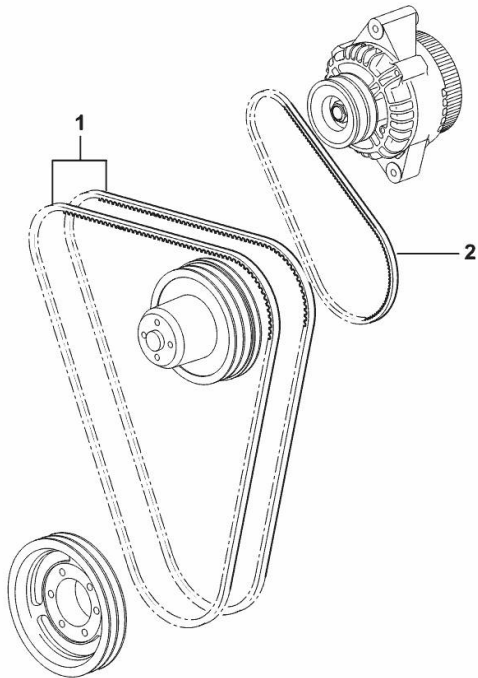

9_34517_11_0-A-001

CRANKSHAFT

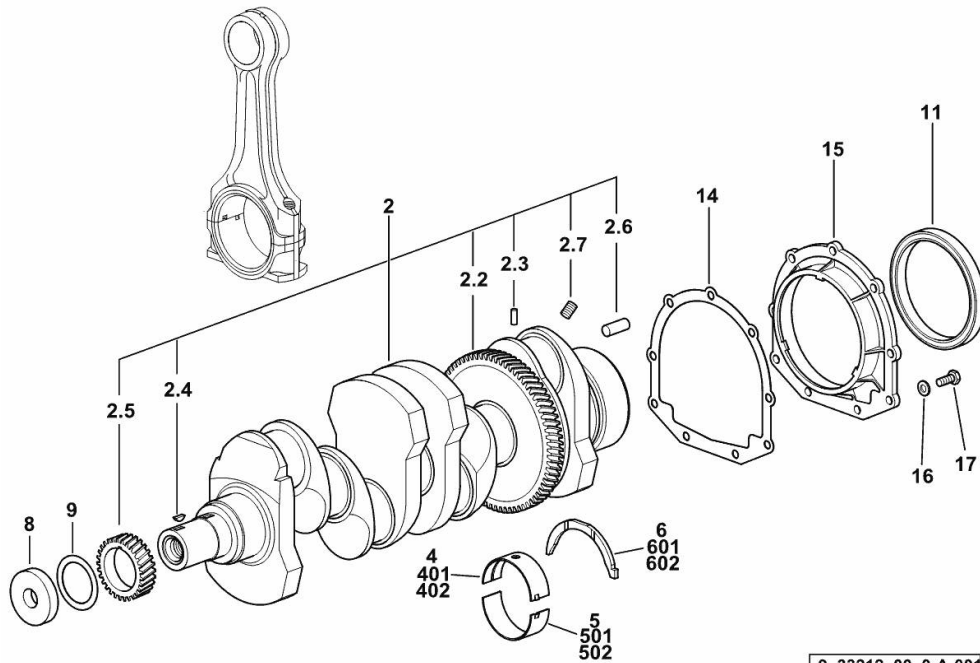

9_33212_00_0-A-001

Fig.	P/n	QTY	Name
------	-----	-----	------

Notes:
[XT-85]

2	0.086.1210.3/40	1	crankshaft
2.2	0.065.1211.0/10	1	crown wheel
2.3	2.1630.608.0	1	pin 6x16
2.4	2.1720.006.0	1	key 4x6.5
2.5	0.065.1323.0/30	1	gear Z = 29
2.6	2.1651.915.0	1	pin 12x35
2.7	2.3130.001.1	4	plug 1/8" gas
4	0.065.1215.0/10	5	main half bushing STANDARD
5	0.065.1216.0/10	5	main half bushing STANDARD
6	0.065.1218.0	4	shim STANDARD
8	2.1599.524.7	1	washer 21x60x12
9	2.1589.189.0	2	shoulder ring mm 1.00
11	2.1529.073.0	1	special oil seal 110x130x13
14	0.065.1254.0/20	1	gasket
15	0.007.1711.0/10	1	cover
16	2.1475.002.2	9	conical washer 8
17	2.0112.207.2	9	screw m 8 p 1.25 x 20
401	0.065.1215.7		main half bushing - mm 0.25
402	0.065.1215.8		main half bushing - mm 0.50
501	0.065.1216.7		main half bushing - mm 0.25
502	0.065.1216.8		main half bushing - mm 0.50
601	0.065.1218.7		shim + mm 0.10
602	0.065.1218.8		shim + mm 0.15



Suggest:

For more complete manuals. Please go to the home page.

<https://www.ebooklibonline.com>

If the above button click is invalid. Please download this document first, and then click the above link to download the complete manual.

Thank you so much for reading

ENGINE FLYWHEEL

Fig.	P/n	QTY	Name
------	-----	-----	------

Notes:

- FOR TYPES WITHOUT HYDRAULIC SHUTTLE [XT-85]

1	0.007.1702.3/30	1	flywheel
1.2	0.065.1242.0	1	crown wheel Z = 123
2	0.008.5543.0	1	flange
3	2.0139.022.2	6	screw m 12 p.1.25x55

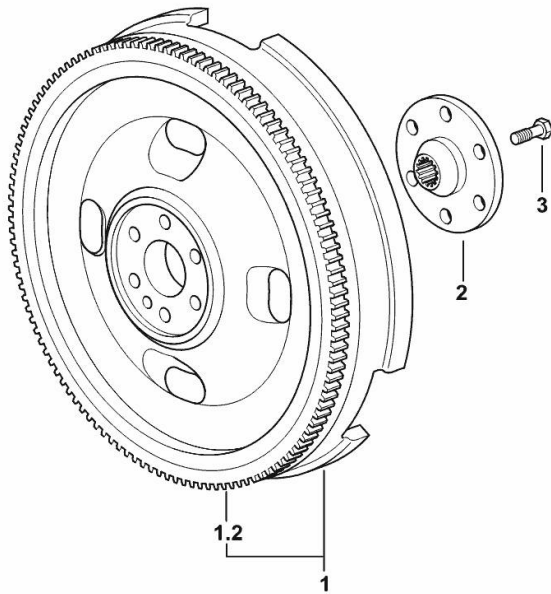

9_32512_03_0-A-001

ENGINE FLYWHEEL

Fig.	P/n	QTY	Name
------	-----	-----	------

Notes:

- FOR TYPES WITHOUT HYDRAULIC SHUTTLE [XT-85]

1	0.012.2626.3/10	1	flywheel
1.2	0.065.1242.0	1	crown wheel Z = 123
2	0.255.2525.0/10	1	flange
3	2.0139.022.2	6	screw m 12 p.1.25x55

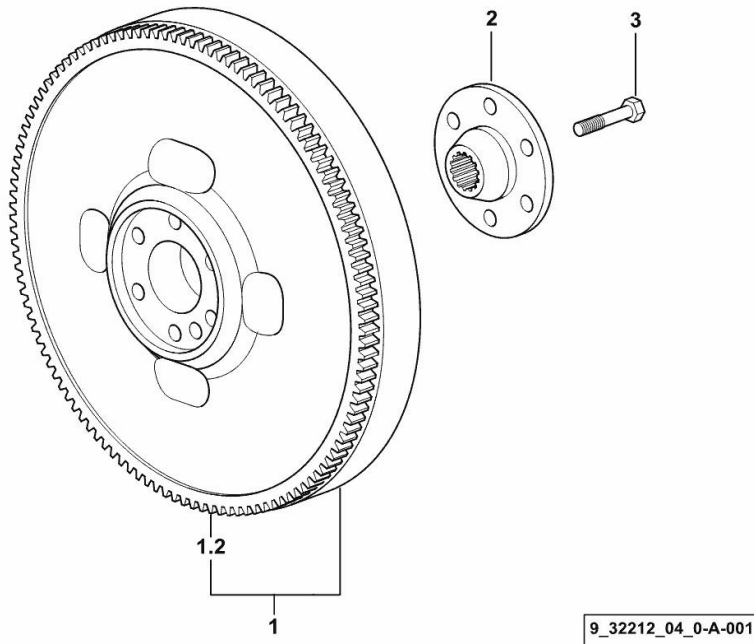

<https://www.ebooklibonline.com>

Hello dear friend!

Thank you very much for reading.

Enter the link into your browser.

The full manual is available for immediate download.

<https://www.ebooklibonline.com>