

Section: ENGINE
CRANKCASE

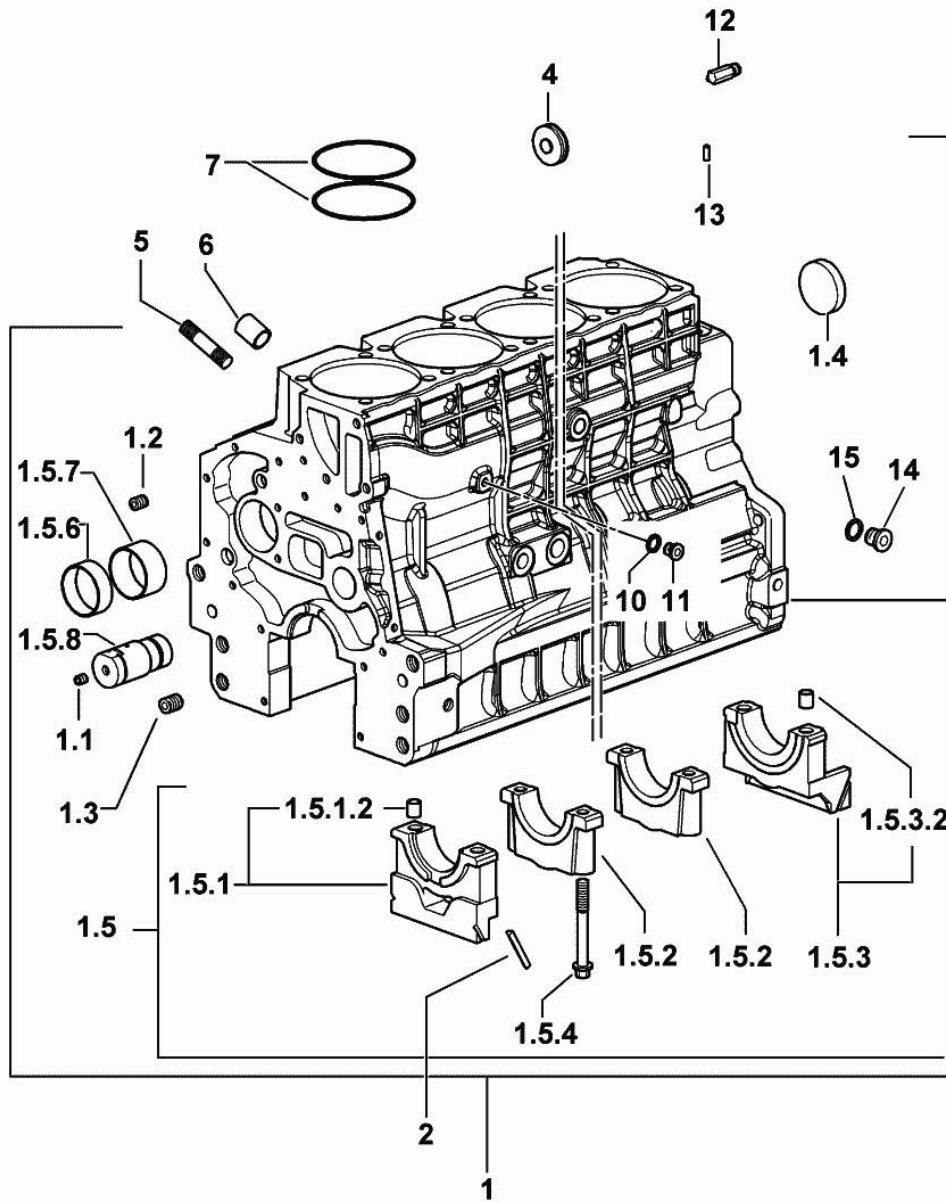

Fig.	P/n	QTY	Name
------	-----	-----	------

Notes:
 [XT 115]

1	0.013.0356.4/30	1	crankcase
1.1	2.3130.001.1	14	plug 1/8" gas
1.2	2.3130.002.1	2	plug 1/4" gas
1.3	2.3130.003.1	8	plug 3/8" gas
1.4	2.3179.012.0	1	plug 60
1.5	0.000.0000.1		cannot be supplied
1.5.1	0.065.1112.7	1	support
1.5.1.2	2.1699.165.0	1	bush 12.3x15x16
1.5.2	0.065.1114.0/10	5	support
1.5.3	0.007.0848.3/20	1	support
1.5.3.2	2.1699.165.0	1	bush 12.3x15x16
1.5.4	0.065.1117.0	14	screw m 12 x 100
1.5.6	0.065.1140.0	6	special bushing 59X55X20
1.5.7	0.065.1141.0	1	special bushing 59X55X30
1.5.8	0.066.1151.0	1	pin
2	0.066.1152.0/10	4	gasket
4	2.3199.312.2/10	1	plug
5	2.0439.273.7	12	stud bolt m 8
6	2.1559.188.2	6	bush 11.4 x 14 x16
7	2.1539.193.0	12	special oil seal 107.62x2.62
10	2.1560.010.0	1	gasket 14.2 x 20
11	2.3199.292.0	1	plug 1/4" gas
12	0.013.4946.0/10	1	sprayer nozzle
13	2.1549.154.2	6	bush 4.8x5.8x16
14	2.3120.101.0	1	plug m 18 p.1.5
15	2.1560.014.0	1	washer 18.2 x 24

9_M3711_00_0_0

Section: ENGINE

MONOBLOC ENGINE-GEARBOX CONNECTING FLANGE

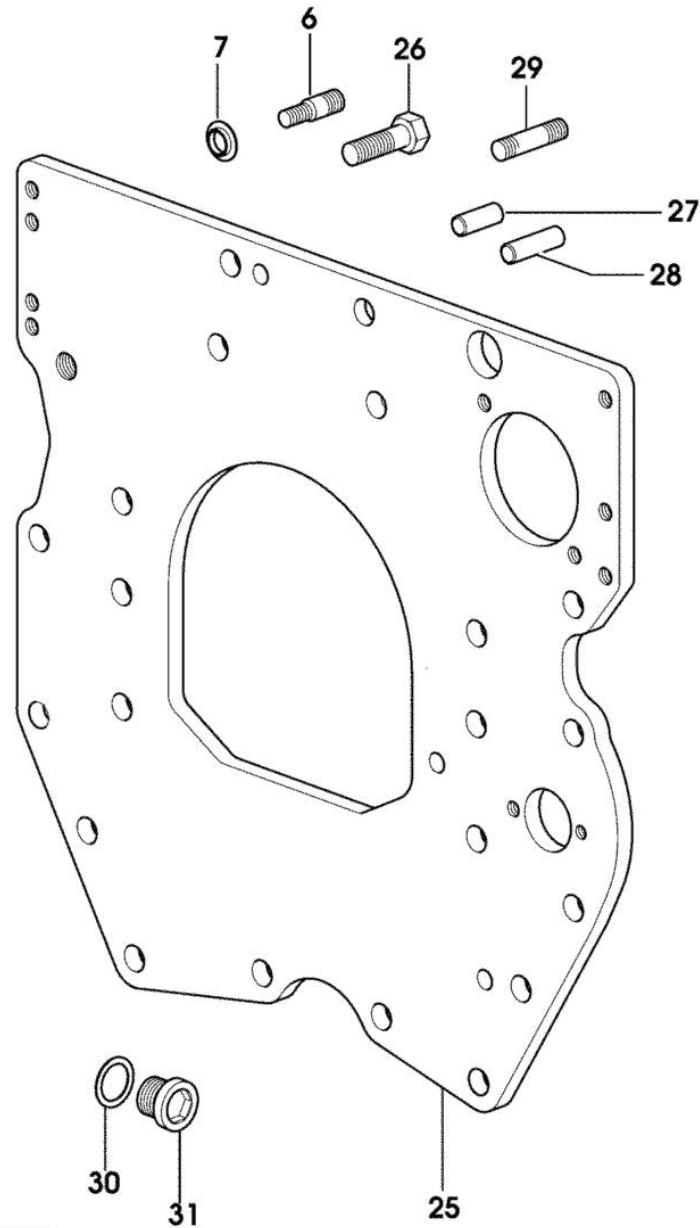

Fig.	P/n	QTY	Name
------	-----	-----	------

Notes:
[XT 115]

6	2.0439.250.7	1	stud bolt m 12 / m 10 x 30
7	0.011.9294.0/10	1	bush
25	0.012.8866.0	1	flange
26	2.0112.511.2	8	screw m 14 p.2 x 30
27	2.1651.912.0	2	cylindrical plug 12x28
28	2.1651.917.0	1	cylindrical plug 12x40
29	2.0432.257.7	1	stud bolt m 12 p.1.75 - 1.25 x 30
30	2.1560.017.0	1	gasket 22.2 x 27
31	2.3120.002.4	1	plug m 22 x 1.5

9_33911_02_0_0

9_M3711_01_0_0

Section: ENGINE
TIMING CASE

Fig.	P/n	QTY	Name
------	-----	-----	------

Notes:
[XT 115]

1	0.013.4981.0	1	guard
11	0.065.1150.0/30	1	gasket
12	2.0432.003.7	2	stud bolt m 8 p.1.25 / p.1 x 20
13	2.0312.219.2	4	screw m 8 p.1.25x65
14	2.1480.014.1	15	washer 8
15	2.1470.004.2	4	lock washer 8
16	2.1011.405.2	2	nut m 8 p.1
17	2.1529.167.0	1	oil seal
18	2.0312.214.2	3	screw m 8 p.1.25 x 40
19	2.0312.208.2	8	screw m 8 p.1.25 x 25

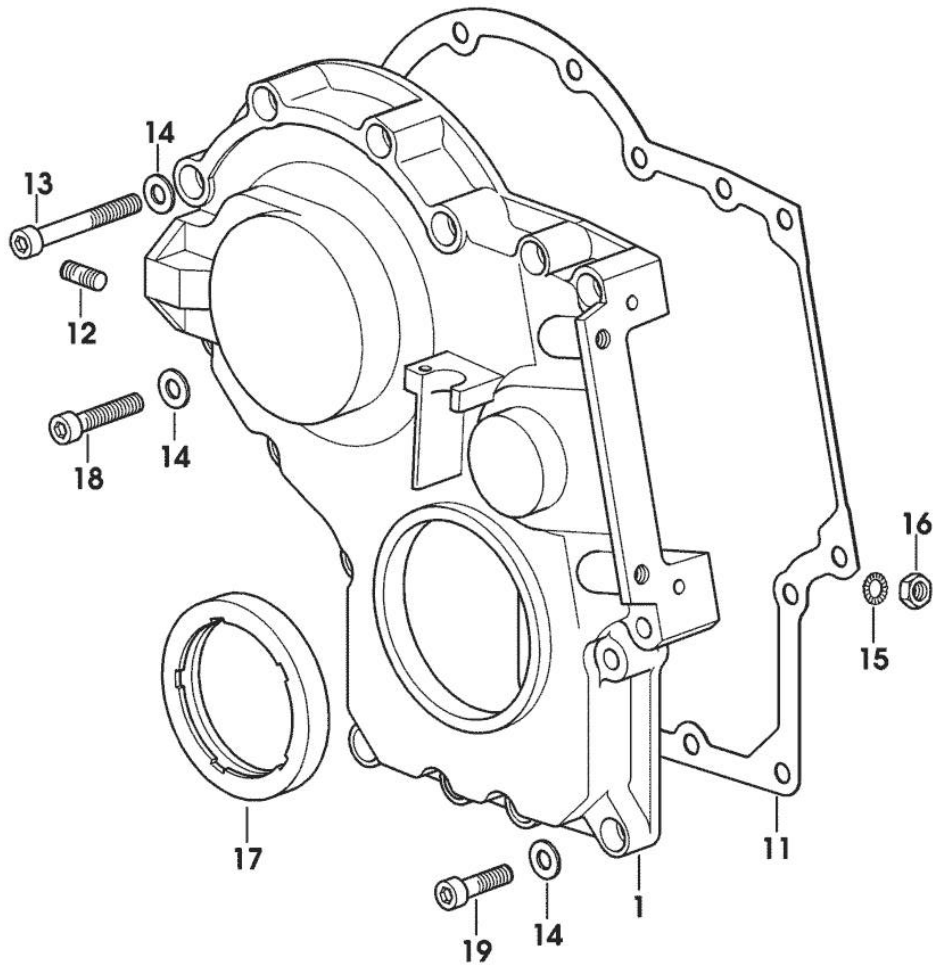

<https://www.ebooklibonline.com>

Hello dear friend!

Thank you very much for reading.

Enter the link into your browser.

The full manual is available for immediate download.

<https://www.ebooklibonline.com>

Section: ENGINE
CASING COVER

Fig.	P/n	QTY	Name
------	-----	-----	------

Notes:
 [XT 115]

30	0.065.1152.0	1	gasket
31	0.065.1151.0	1	cover
32	2.0112.205.2	2	screw m 8 p.1.25 x 16
34	2.0432.005.7	2	stud bolt m 8 p.1.5 / p.1 x 25

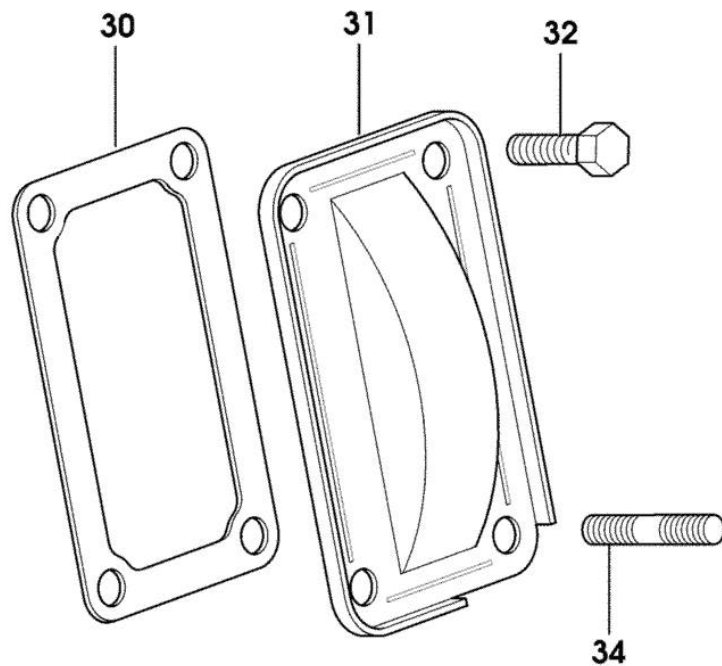

9_33011_04_0_0

Section: ENGINE

GUARD PLATE

Fig.	P/n	QTY	Name
------	-----	-----	------

Notes:
[XT 115]

1	0.007.1262.3/50	1	guard
2	0.007.1271.0/10	1	small column m 8 p.1.25 / L = mm 60
3	0.007.1272.0/10	2	small column m 8 p.1.25 / L = mm 50
5	2.1310.004.2	3	flat washer 8.4x17
7	2.0112.203.2	3	screw m 8 p.1.25 x 12

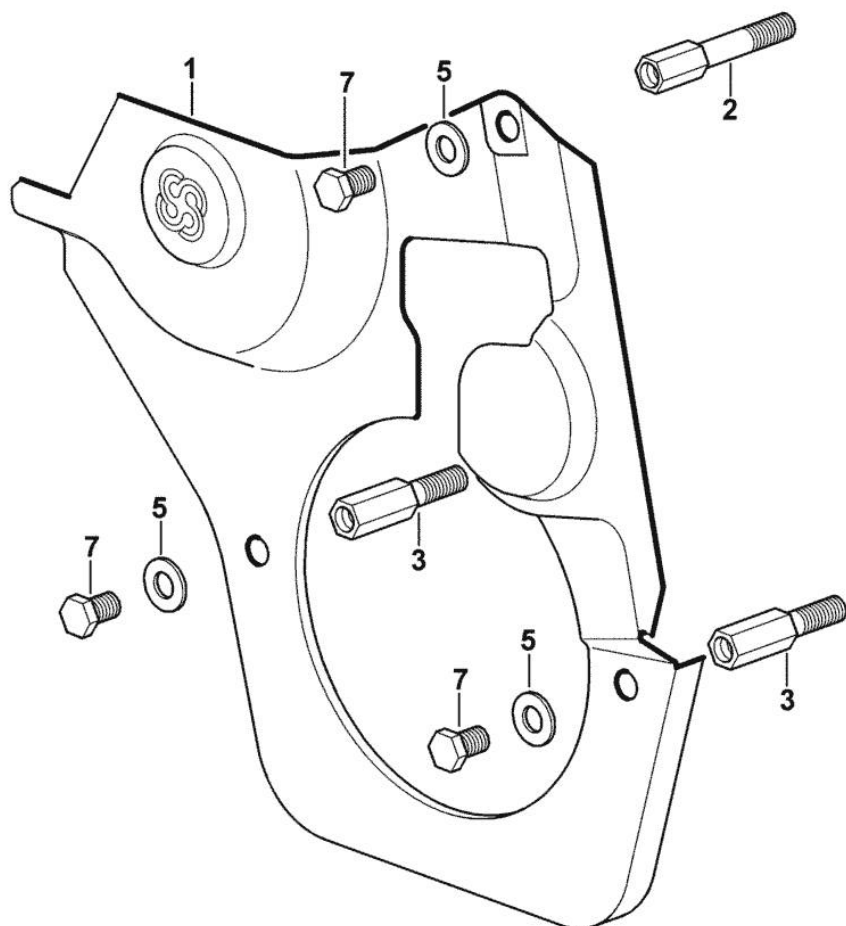

Section: ENGINE
CRANKSHAFT

Fig.	P/n	QTY	Name
------	-----	-----	------

Notes:
 [XT 115]

2	2.1651.915.0	1	pin 12x35
3	0.065.1215.0	7	main half bushing STANDARD
3	0.065.1215.7		main half bushing - mm 0.25
3	0.065.1215.8		main half bushing - mm 0.50
4	0.065.1216.0	7	main half bushing
4	0.065.1216.7		main half bushing - mm 0.25
4	0.065.1216.8		main half bushing - mm 0.50
5	0.065.1218.0	4	shim STANDARD
5	0.065.1218.7		shim + mm 0.10
5	0.065.1218.8		shim + mm 0.15
6	2.1599.524.7	1	washer 21x60x12
7	2.1720.006.0	1	key 4x6.5
9	0.065.1254.0/20	1	gasket
10	0.007.0851.0/10	1	cover
11	2.1529.073.0	1	special oil seal 110x130x13
12	2.1475.002.2	9	conical washer 8
13	2.0112.207.2	7	screw m 8 p 1.25 x 20
14	2.3130.001.1	6	plug 1/8" gas
15	2.1589.137.0	2	shoulder ring 71x110x1
16	2.0432.003.7	2	stud bolt m 8 p.1.25 / p.1 x 20
17	2.1011.105.2	2	nut m 8 p.1.25
20	0.009.3704.3	1	antivibration pulley
21	0.010.4320.3/20	1	crankshaft
21.2	0.007.0855.0/10	1	gear
22	0.011.2206.0/20	1	hub
23	2.0399.144.7/10	1	screw m 20 p.1.5x51

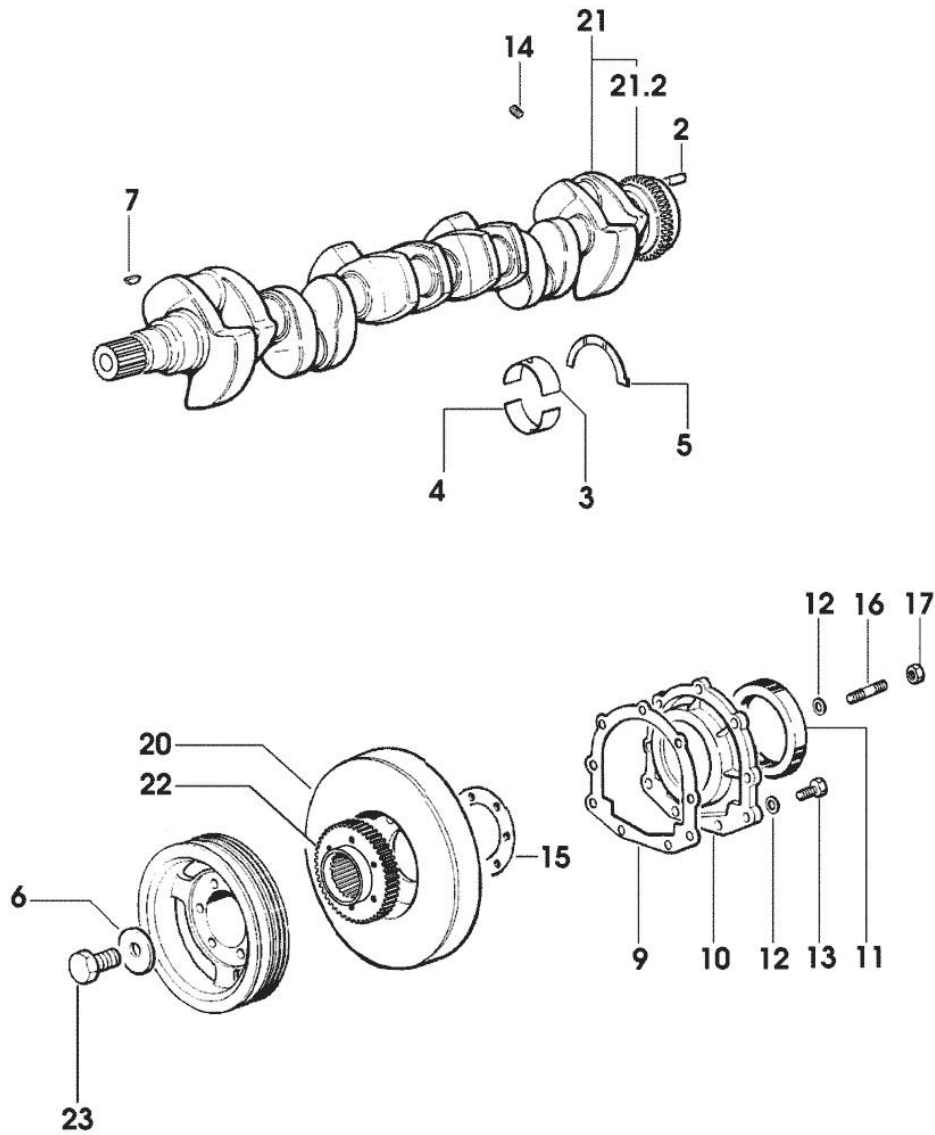

9_37912_00_0_0

Section: ENGINE

CYLINDER - PISTON - CONNECTING ROD

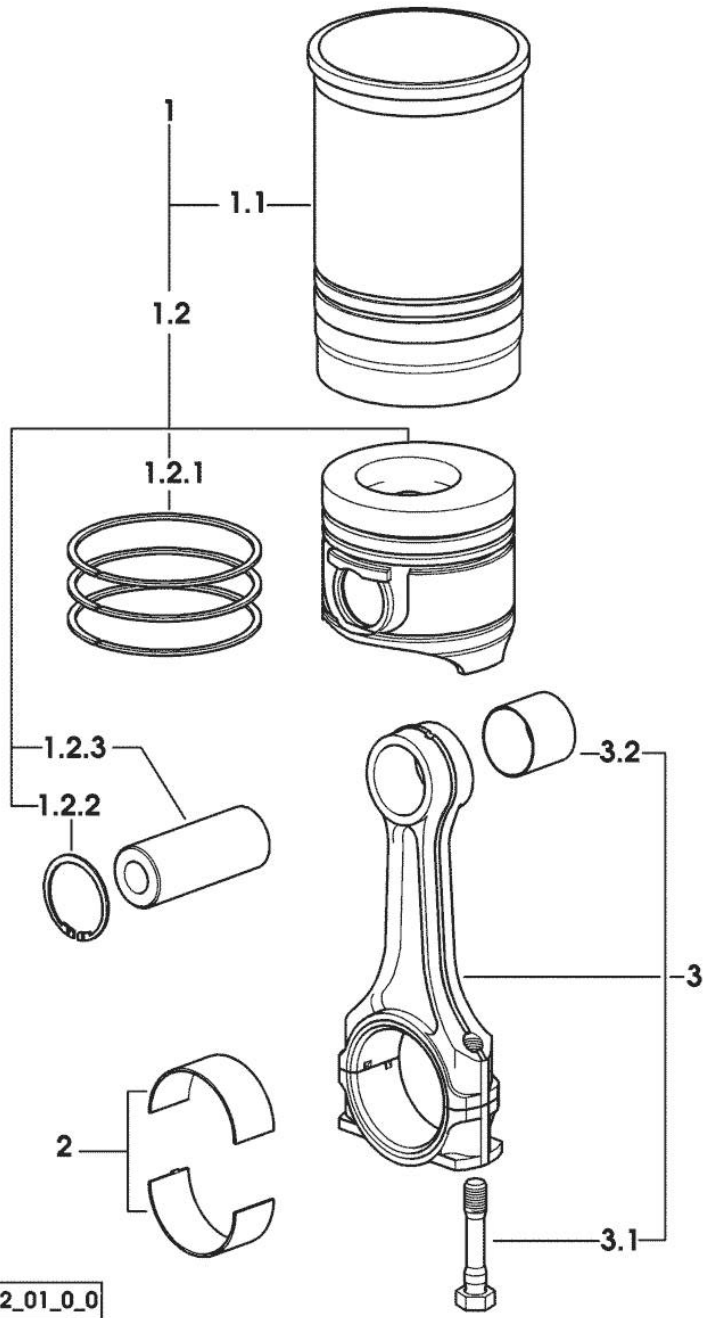

Fig.	P/n	QTY	Name
------	-----	-----	------

Notes:
[XT 115]

1	0.099.0065.A	6	cyl. piston assembly "A" - CLASS A
1	0.099.0065.B	6	cyl. piston assembly "B" - CLASS B
1.1	0.A12.2675.0	1	engine cylinder "A" - CLASS A
1.1	0.B12.2675.0	1	engine cylinder "B" - CLASS B
1.2	0.099.0060.A	1	complete piston "A" - CLASS A
1.2	0.099.0060.B	1	complete piston "B" - CLASS B
1.2.1	0.081.0090.6/10	1	piston ring set
1.2.2	2.1411.014.1	2	circlip 35
1.2.3	0.078.1236.0	1	piston pin Ø 18 / Ø 35 / L = mm 86
2	0.065.1225.0	12	con.rod half bushing STANDARD - A = 28.75 -> 29.00
2	0.065.1225.7	12	con.rod half bushing - mm 0.25
2	0.065.1225.8	12	con.rod half bushing - mm 0.50
3	0.078.1220.3/30	6	engine connecting rod
3.1	2.0399.213.0	2	screw m 12 p.1.25x61.5
3.2	2.1559.114.0/10	1	special bushing

9_M8012_01_0_0

Section: ENGINE

CRANKSHAFT PULLEY

Fig.	P/n	QTY	Name
------	-----	-----	------

Notes:
[XT 115]

1	0.007.0962.0/30	1	pulley
2	2.0112.322.2	6	screw m 10 p.1.5x65
3	2.1470.006.2	6	lock washer 10

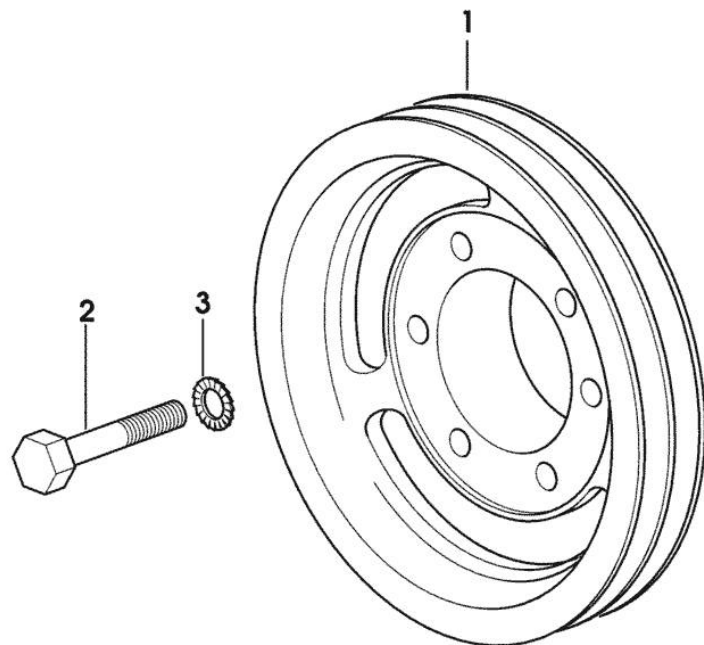

9_33712_01_0_0

Section: ENGINE

FLYWHEEL

Fig.	P/n	QTY	Name
------	-----	-----	------

Notes:
[XT 115]

1	0.013.2935.3	1	flywheel
1.2	0.065.1242.0	1	crown wheel Z = 123
2	0.288.3625.0	1	flange
3	2.0139.022.2	6	screw m 12 p.1.25x55

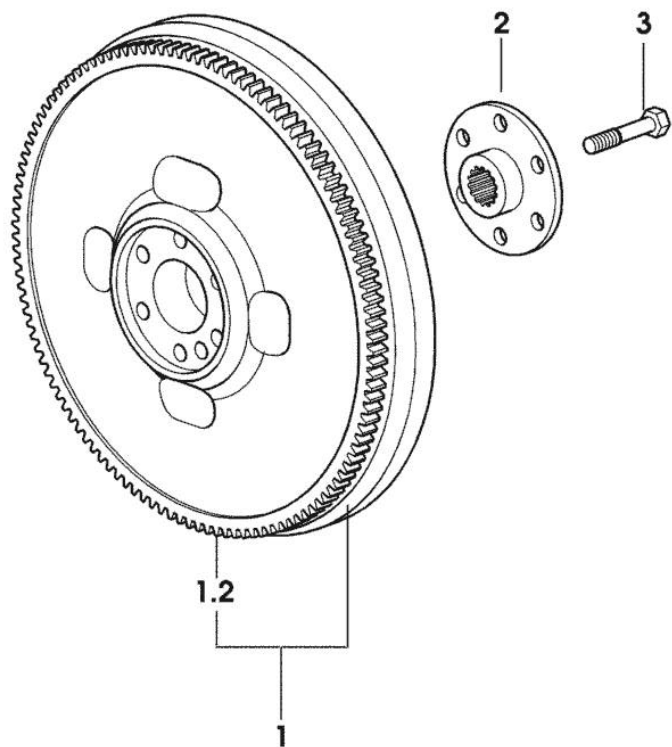

9_33912_01_0_0

Section: ENGINE

CAMSHAFT

Fig.	P/n	QTY	Name
------	-----	-----	------

Notes:
[XT 115]

1	0.065.1331.2	12	rod
2	0.012.3678.3	1	camshaft
2.2	0.065.1324.0/10	1	gear Z = 32
3	0.065.1330.0	12	tappets
4	2.1559.398.0	1	bushing 10.5x13x12
5	0.013.5017.0	1	gear z=58
6	0.065.1350.0	1	small disc
7	2.0132.207.2	4	screw m 10 p.1 x 25
8	2.1410.016.1	1	circlip 40
9	0.065.1352.0	1	shim
10	0.065.1351.0	2	shoulder ring
11	0.007.1188.0/30	1	gear Z = 29
12	0.007.1177.3/20		gear z = 57
			- WITH RED IDENTIFICATION STAMP
12.2	2.1559.185.0/10	1	bushing
13	0.007.1178.3/20		gear z = 57
			- WITH YELLOW IDENTIFICATION STAMP
13.2	2.1559.185.0/10	1	bushing
14	0.007.1179.3/20		gear z = 57
			- WITH GREEN IDENTIFICATION STAMP
14.2	2.1559.185.0/10	1	bushing
15	2.0312.205.2	2	screw
16	2.1480.014.1	2	washer 8
17	0.065.1353.0	1	small plate

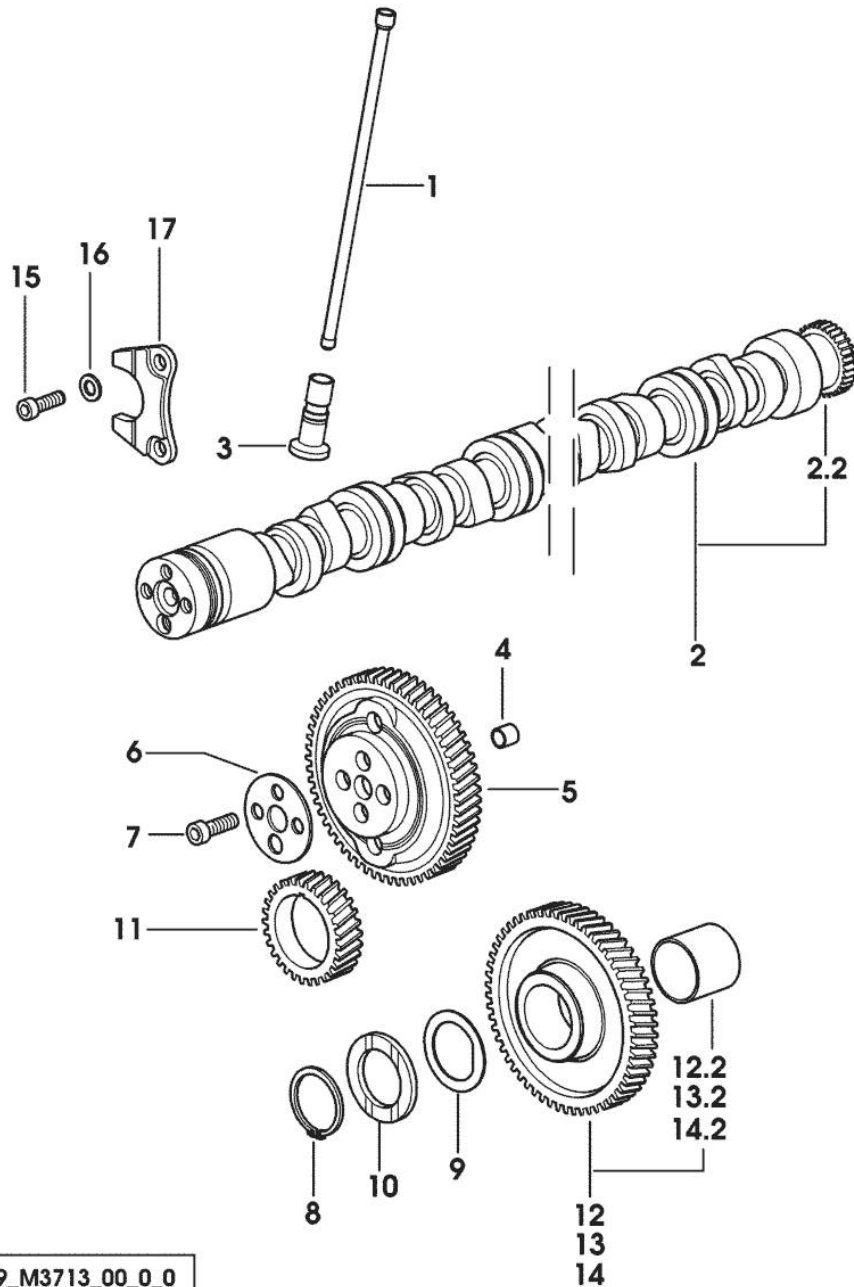

9_M3713_00_0_0



Suggest:

For more complete manuals. Please go to the home page.

<https://www.ebooklibonline.com>

If the above button click is invalid. Please download this document first, and then click the above link to download the complete manual.

Thank you so much for reading

Section: ENGINE
CYLINDER HEAD

Fig.	P/n	QTY	Name
------	-----	-----	------

Notes:
[XT 115]

1	0.013.0412.3/60	6	engine head
1.2	0.078.1426.0	1	valve seat
1.3	0.066.1427.0	1	valve seat
1.4	0.007.1779.0/20	2	valve guide
1.5	0.012.9984.0/20	1	bush
1.6	2.3170.012.1	2	expansion plug 30
2	2.0432.011.7	6	stud bolt m 8 p.1.25 / p.1 x 40
3	2.0432.005.7	6	stud bolt m 8 p.1.5 / p.1 x 25
6	0.074.1423.0	24	conical valve cotter
7	0.066.1425.0	12	cup
8	2.4019.287.0	12	spring
9	0.012.2673.0	24	screw m 14 p.2x141
10	0.000.0000.1		cannot be supplied
10.1	0.066.1431.0	1	pin
10.2	0.021.1434.0	2	screw
10.10	0.000.0000.1		cannot be supplied
10.10.3	2.1011.405.2	2	nut m 8 p.1
10.10.4	0.066.1432.3	2	rocker arm
10.10.4.2	2.1559.021.0/40	1	bushing 15x19x22
10.10.5	2.1410.055.7	2	circlip 19
10.10.6	0.000.0000.1		cannot be supplied
10.10.6.2	0.066.1430.0/10	1	support
10.10.7	2.1599.432.0	2	shoulder ring
14	2.0432.163.7	6	stud bolt m 10 p.1.5 / p.1.25 x 45
15	2.1011.421.2	12	nut m 10 p.1.25
18	2.0432.161.7	6	stud bolt m 10 p.1.5 / p.1.25 x 40
19	2.1532.507.0	6	oil seal 17x3.53
20	0.013.1887.0	4	gasket
21	0.013.1888.0	6	gasket
22	0.013.1889.0	2	gasket
32	0.009.3877.0/10	2	tappet gasket
33	2.0399.288.2/10	6	screw m 8x36x46
34	2.1539.151.0	6	special oil seal 9.19 x 2.62
35	2.6859.091.0	2	clamp
36	0.075.1452.0/10	1	sleeve
			5005 <- X XT 115
			5018 <- X XT 130
			5005 <- X XT 115
			5018 <- X XT 130
37	2.1519.117.0	12	special oil seal
38	0.010.6509.0	1	cap

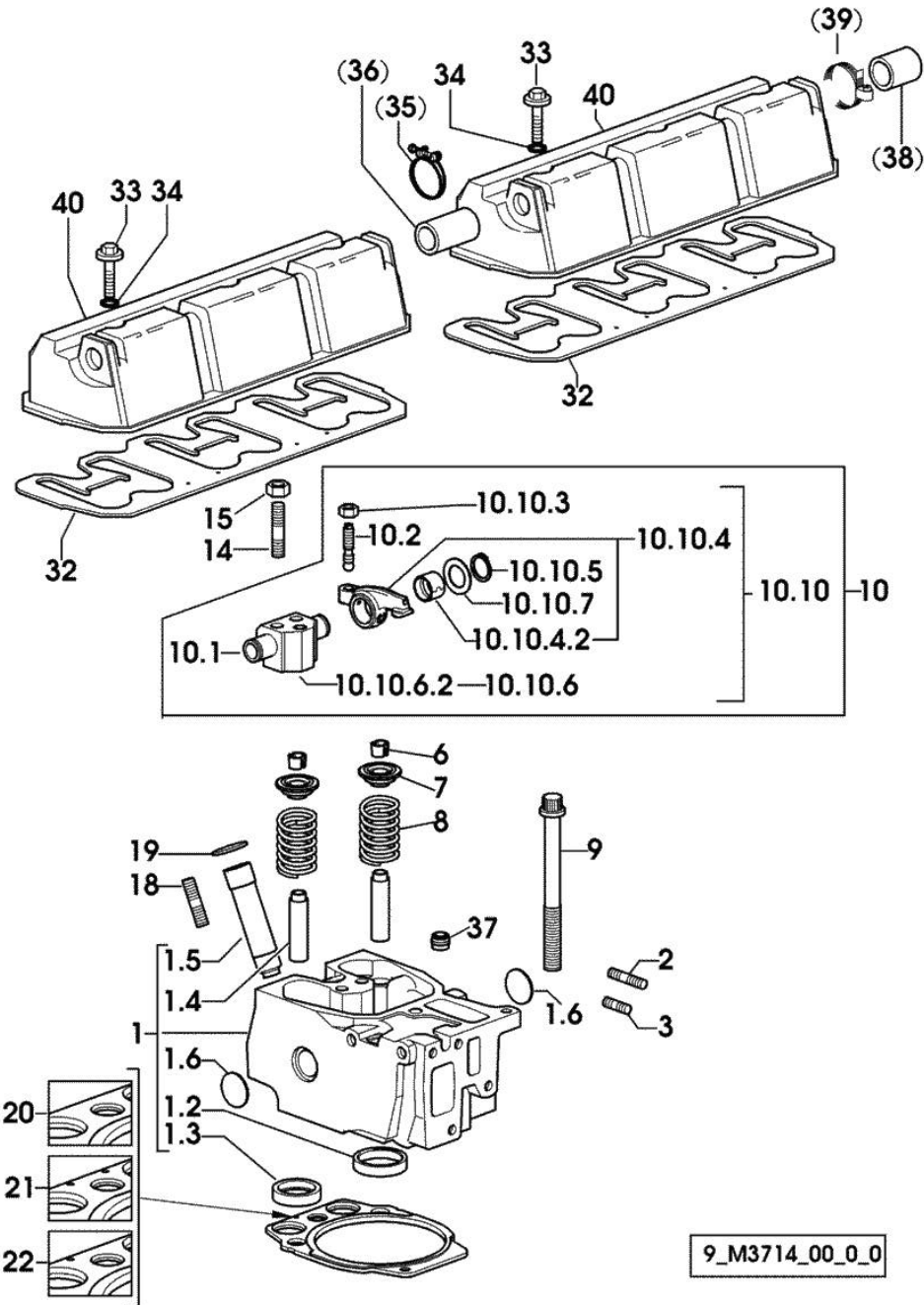

Section: ENGINE
CYLINDER HEAD

Fig.	P/n	QTY	Name
39	2.6851.003.0	1	5005 <- X XT 115 5018 <- X XT 130 clamp Ø 25/40
40	0.014.0696.0	2	5005 <- X XT 115 5018 <- X XT 130 cover

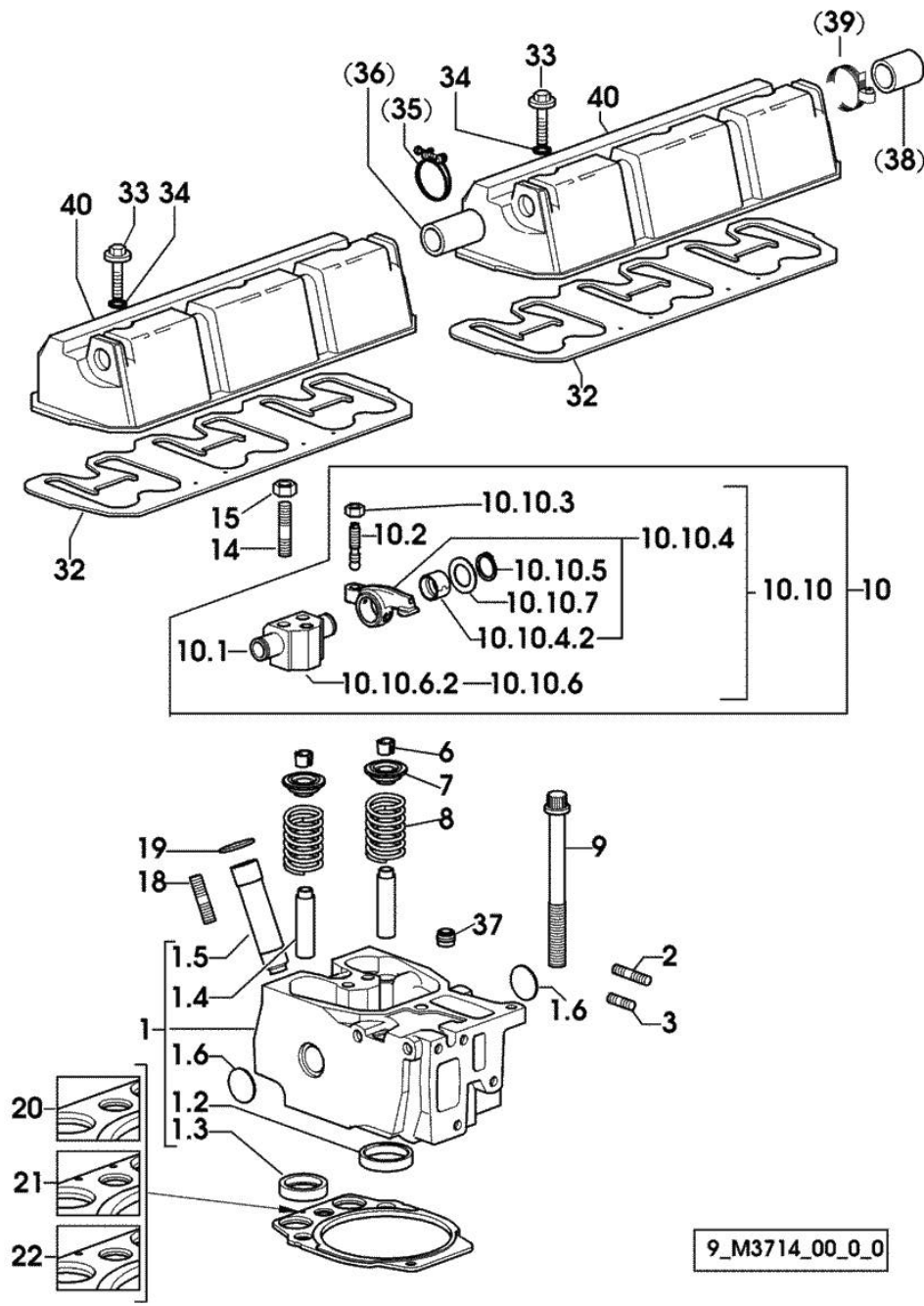

9_M3714_00_0_0

<https://www.ebooklibonline.com>

Hello dear friend!

Thank you very much for reading.

Enter the link into your browser.

The full manual is available for immediate download.

<https://www.ebooklibonline.com>