

Product: VIBRATORY COMPACTOR

Model: CB-224D VIBRATORY COMPACTOR 8RZ

Configuration: CB-214D CB-224D CB-225D Vibratory Compactors 8RZ00001-UP (MACHINE) POWERED BY 3013 Engine

## **Disassembly and Assembly 3003, 3013, 3014 and 3024 Engines for Caterpillar Built Machines**

Media Number -SEN5027-05

Publication Date -01/05/2005

Date Updated -16/05/2005

i02399591

# **Engine Oil Pump - Remove**

SMCS - 1304-011

## **Removal Procedure**

### **Start By:**

- A. Remove the engine oil pan. Refer to Disassembly and Assembly, "Engine Oil Pan - Remove and Install".
- B. Remove the front housing. Refer to Disassembly and Assembly, "Housing (Front) - Remove".

---

### **NOTICE**

**Keep all parts clean from contaminants.**

**Contaminants may cause rapid wear and shortened component life.**

---

---

### **NOTICE**

**If the front housing is not installed, do not turn the crankshaft.  
Damage to the engine may occur.**

---

---

### **NOTICE**

Care must be taken to ensure that fluids are contained during performance of inspection, maintenance, testing, adjusting and repair of the product. Be prepared to collect the fluid with suitable containers before opening any compartment or disassembling any component containing fluids.

Refer to Special Publication, NENG2500, "Caterpillar Dealer Service Tool Catalog" for tools and supplies suitable to collect and contain fluids on Caterpillar products.

Dispose of all fluids according to local regulations and mandates.

---

## Engine Oil Pump

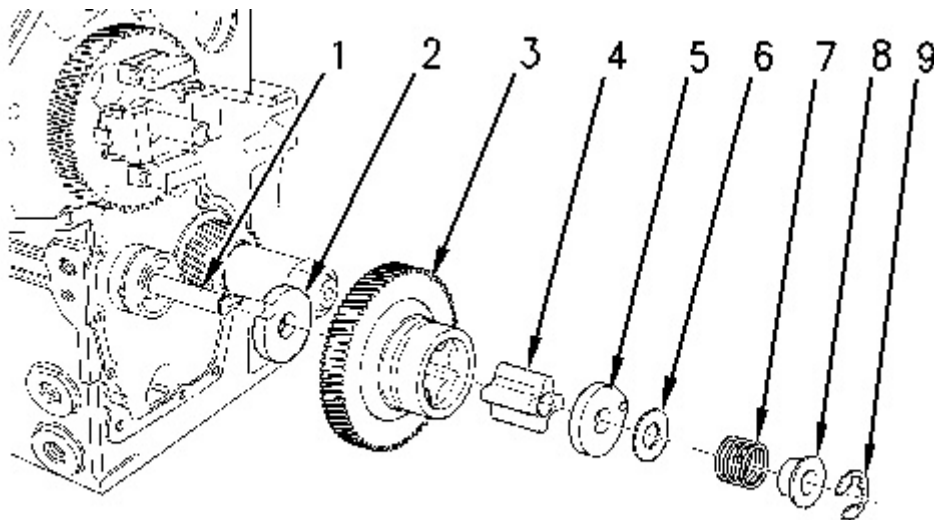

---

Illustration 1

g00825411

### **WARNING**

Personal injury can result from being struck by parts propelled by a released spring force.

Make sure to wear all necessary protective equipment.

Follow the recommended procedure and use all recommended tooling to release the spring force.

---

1. Remove retaining ring (9) that retains idler gear (3) on idler hub (1) .
  2. Remove the following items from idler hub (1) :
    - Collar (8)
    - Spring (7)
    - Shim (6)
    - Oil pump cover (5)
    - Inner rotor (4)
  3. Remove idler gear (3) from idler hub (1) .
  4. Remove thrust washer (2) from idler hub (1) .
  5. Inspect all the components for wear or damage. If components are worn or damaged, use new parts for replacement.
- Note:** Refer to Specifications, "Engine Oil Pump" for more information.
6. If the engine oil pump has excessive buildup of sludge, inspect the oil strainer. The oil strainer can be removed by using the following procedure:
    - a. Remove the engine oil pan. Refer to Disassembly and Assembly, "Engine Oil Pan - Remove and Install".

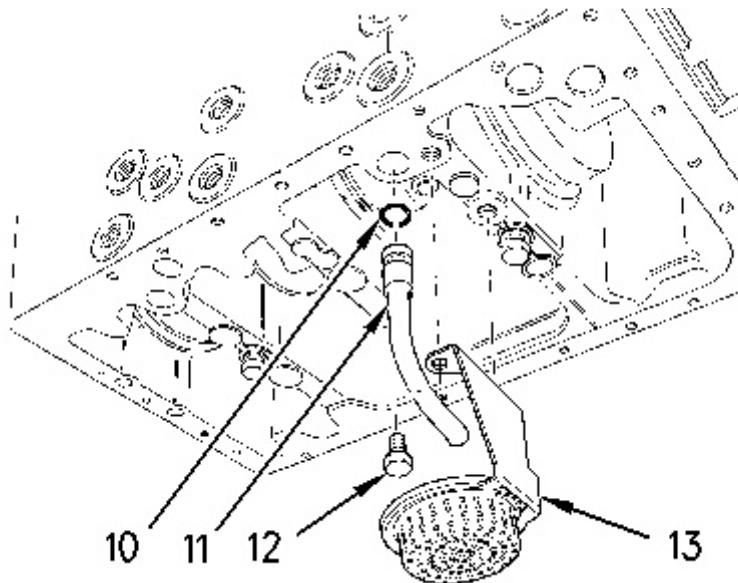

---

Illustration 2

g00825406

- b. Remove bolts (12) and oil strainer (13) from the cylinder block. Inspect the oil strainer for damage. If the oil strainer is damaged, use a new part for replacement.
- c. Remove tube assembly (11) from the cylinder block.

**<https://www.ebooklibonline.com>**

Hello dear friend!

Thank you very much for reading.

Enter the link into your browser.

The full manual is available for immediate download.

**<https://www.ebooklibonline.com>**

- d. Remove O-ring seal (10) from the tube assembly. Inspect the O-ring seal for wear or damage. If the O-ring seal is worn or damaged, use a new part for replacement.

## Idler Hub

Table 1

Required Tools			
Tool	Part Number	Part Description	Qty
A	1P-0074	Slide Hammer Puller	1

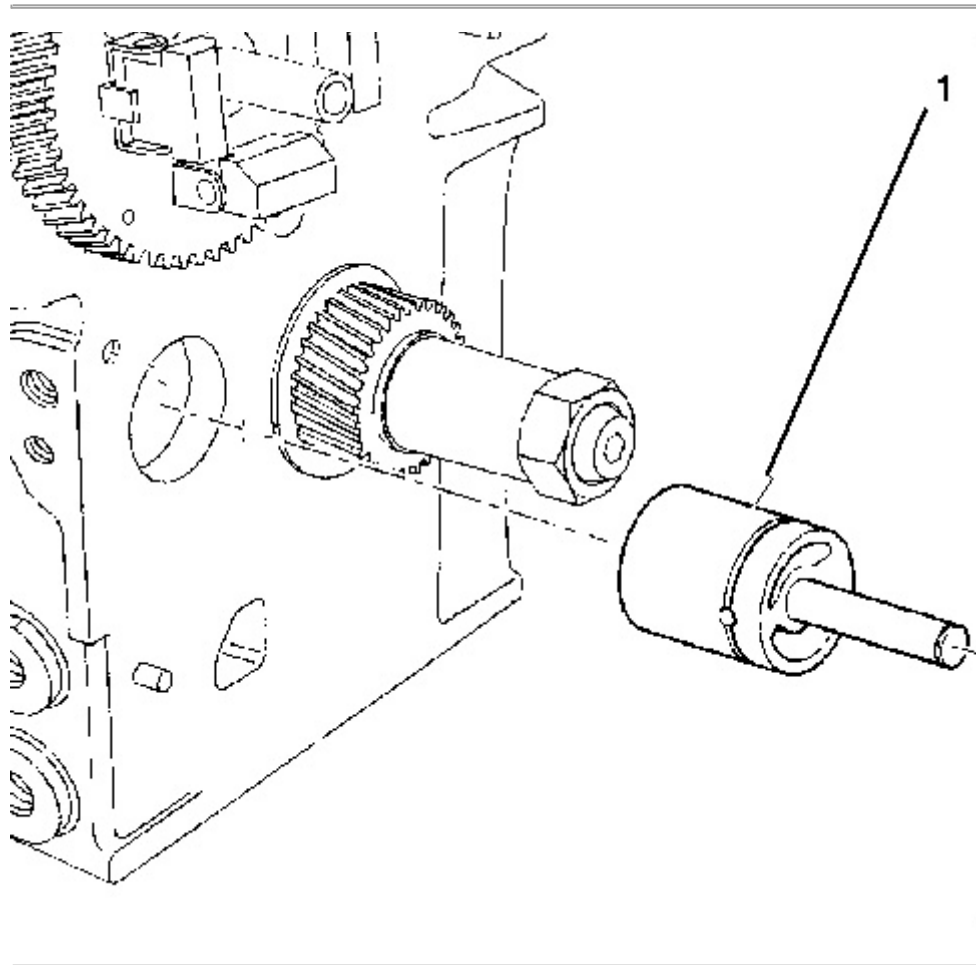

Illustration 3

g01037604

1. Use Tooling (A) to remove idler hub (1) from the cylinder block.

Product: VIBRATORY COMPACTOR

Model: CB-224D VIBRATORY COMPACTOR 8RZ

Configuration: CB-214D CB-224D CB-225D Vibratory Compactors 8RZ00001-UP (MACHINE) POWERED BY 3013 Engine

## Disassembly and Assembly 3003, 3013, 3014 and 3024 Engines for Caterpillar Built Machines

Media Number -SEN5027-05

Publication Date -01/05/2005

Date Updated -16/05/2005

i03121381

# Engine Oil Pump - Install

SMCS - 1304-012

## Installation Procedure

Table 1

Required Tools			
Tool	Part Number	Part Description	Qty
B	8T-5096	Dial Indicator Test Group	1
C <sup>(1)</sup>	256-4864	Alignment Tool	
C <sup>(2)</sup>	241-4232	Alignment Tool	1
D	1S-0257	Ball Peen Hammer	1
E	1P-0808	Multipurpose Grease	1

<sup>(1)</sup> 3003 engines

<sup>(2)</sup> 3013, 3014 and 3024 engines

---

### NOTICE

**Keep all parts clean from contaminants.**

**Contaminants may cause rapid wear and shortened component life.**

---

---

### NOTICE

**If the front housing is not installed, do not turn the crankshaft.  
Damage to the engine may occur.**

---

## **Idler Hub**

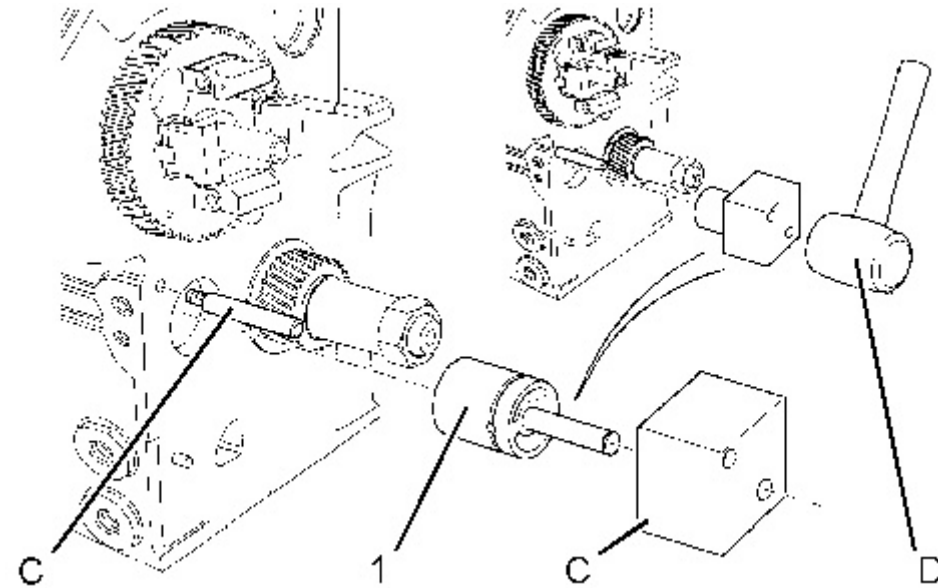

Illustration 1

g01198501

1. Use Tooling (C) and Tooling (D) to install idler hub (1) in the cylinder block.

## **Engine Oil Pump**

---

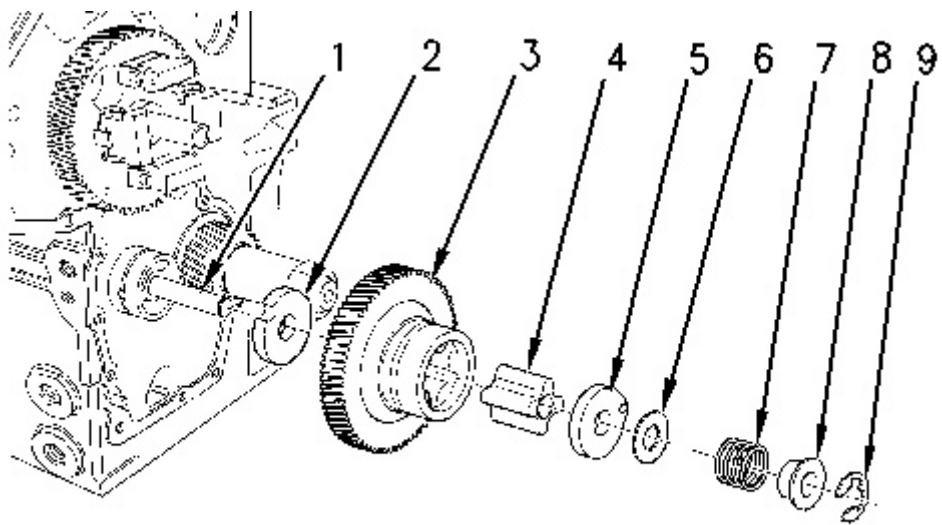

Illustration 2

g00825411

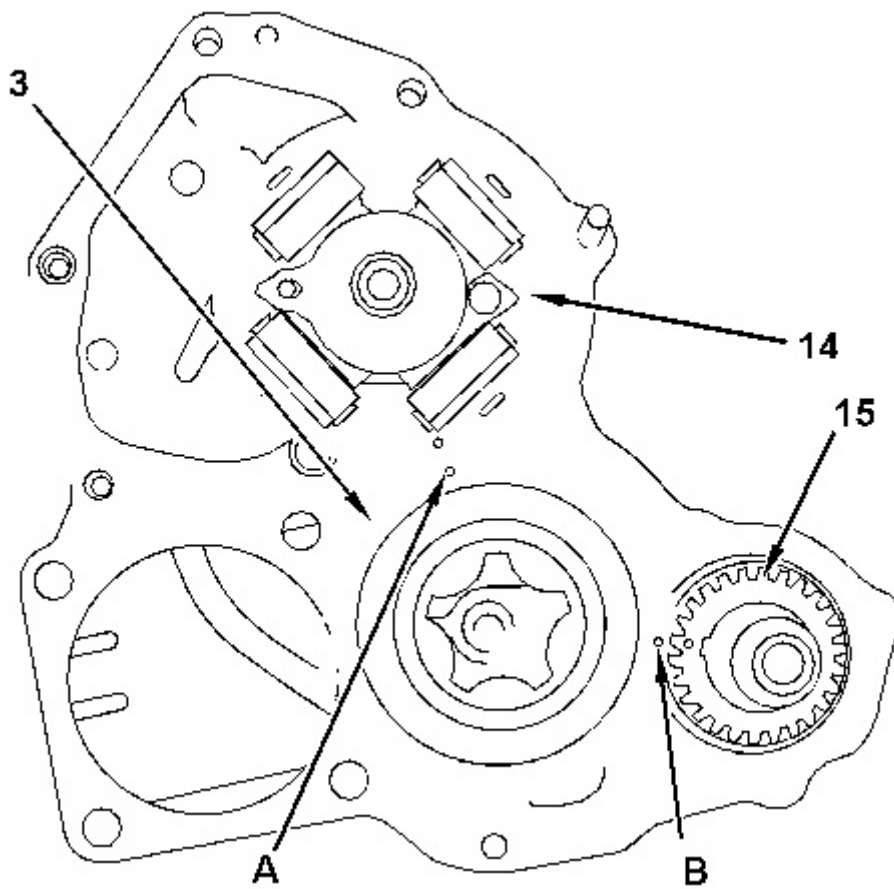

Illustration 3

g01037617

 **WARNING**

**Improper assembly of parts that are spring loaded can cause bodily injury.**

**To prevent possible injury, follow the established assembly procedure and wear protective equipment.**

---

1. Apply Tooling (E) to the faces of inner rotor (4) and to the vanes of idler gear (3) .
2. Align Timing Marks (A) and (B) that are on idler gear (3) with the respective timing marks on gears (14) and (15) . Install idler gear (3) on idler hub (1) .
3. Install inner rotor (4) in idler gear (3) .



**Personal injury can result from the release of the spring force.**

**The drive shaft, the piston, and the drive gear are under spring force.**

**Use a press to slowly release the spring force before the components are removed.**

---

4. Install the following items on idler hub (1) :
    - Oil pump cover (5)
    - Shim (6)
    - Spring (7)
    - Collar (8)
  5. Install retaining ring (9) on idler hub (1) .
  6. Use Tooling (B) in order to measure the end play of the engine oil pump. Refer to Specifications, "Engine Oil Pump".
  7. If the oil strainer was removed, use the following procedure for installation:
-

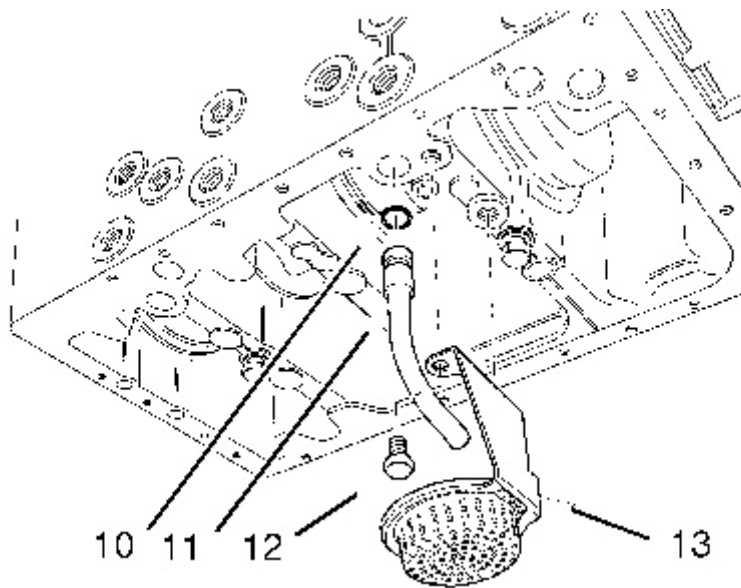

---

Illustration 4

g01037619

- a. Install O-ring seal (10) on tube assembly (11) .
- b. Install tube assembly (11) in the cylinder block.
- c. Install oil strainer (13) on the cylinder block and tighten bolts (12) to a torque of 11 N·m (97 lb in).

**End By:**

- a. Install the front housing. Refer to Disassembly and Assembly, "Housing (Front) - Install".
  - b. Install the engine oil pan. Refer to Disassembly and Assembly, "Engine Oil Pan - Remove and Install".
-

Product: VIBRATORY COMPACTOR

Model: CB-224D VIBRATORY COMPACTOR 8RZ

Configuration: CB-214D CB-224D CB-225D Vibratory Compactors 8RZ00001-UP (MACHINE) POWERED BY 3013 Engine

## Disassembly and Assembly 3003, 3013, 3014 and 3024 Engines for Caterpillar Built Machines

Media Number -SEN5027-05

Publication Date -01/05/2005

Date Updated -16/05/2005

i02350237

### Flywheel - Remove

SMCS - 1156-011

### Removal Procedure ( 3003 Engine)

#### Start By:

- A. Remove the flywheel housing. Refer to Disassembly and Assembly, "Flywheel Housing - Remove and Install".

---

#### NOTICE

**Keep all parts clean from contaminants.**

**Contaminants may cause rapid wear and shortened component life.**

---

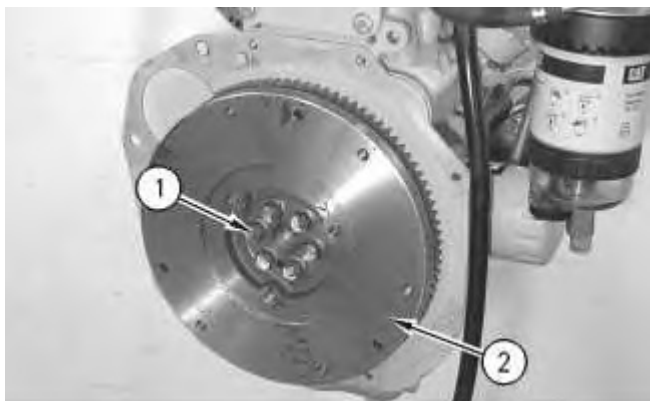

Illustration 1

g00582471

1. Remove bolts (1) .
2. Remove flywheel (2) .
3. If removal of the flywheel ring gear is necessary, place an index mark on the flywheel and the flywheel ring gear for the installation process.



Illustration 2

g00683054

Typical example

4. Use a hammer and a punch in order to remove flywheel ring gear (3) from flywheel (2) .
5. Inspect the flywheel ring gear and the flywheel for wear or damage. If the flywheel ring gear or the flywheel is worn or damaged, use new parts for replacement.

## Removal Procedure ( 3013, 3014, and 3024 Engines)

Table 1

Required Tools			
Tool	Part Number	Part Description	Qty
A	138-7573	Link Bracket	1
B	-	Guide Bolt (M10 x 1.25 mm)	2

### Start By:

- A. Remove the electric starting motor. Refer to Disassembly and Assembly, "Electric Starting Motor - Remove and Install".

---

### NOTICE

**Keep all parts clean from contaminants.**

**Contaminants may cause rapid wear and shortened component life.**

---

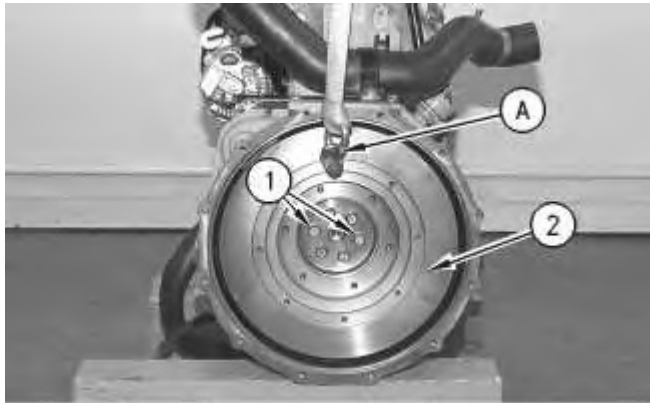

Illustration 3

g00582825

1. Attach Tooling (A) and a suitable lifting device to flywheel (2) . The weight of flywheel (2) is approximately 34 kg (75 lb).
2. Remove two bolts (1) opposite each other from the flywheel.
3. Install Tooling (B) .
4. Remove remaining bolts (1) .

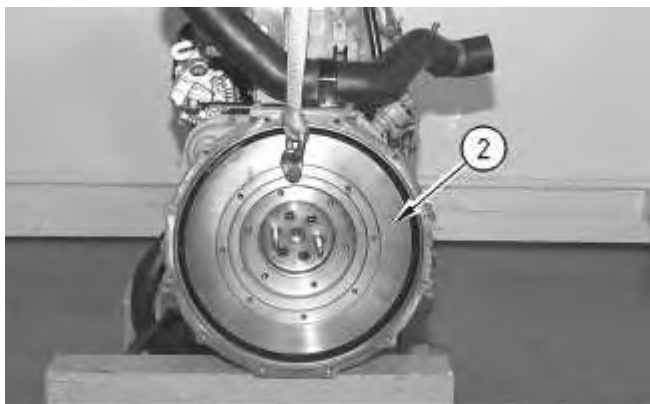

Illustration 4

g00584293

5. Remove flywheel (2) .
  6. If removal of the flywheel ring gear is necessary, place an index mark on the flywheel and the flywheel ring gear for the installation process.
-



---

Illustration 5

g00683054

Typical example

7. Use a hammer and a punch in order to remove flywheel ring gear (3) from flywheel (2) .
  8. Inspect the flywheel ring gear and the flywheel for wear or damage. If the flywheel ring gear or the flywheel is worn or damaged, use new parts for replacement.
-

Product: VIBRATORY COMPACTOR

Model: CB-224D VIBRATORY COMPACTOR 8RZ

Configuration: CB-214D CB-224D CB-225D Vibratory Compactors 8RZ00001-UP (MACHINE) POWERED BY 3013 Engine

## Disassembly and Assembly 3003, 3013, 3014 and 3024 Engines for Caterpillar Built Machines

Media Number -SEN5027-05

Publication Date -01/05/2005

Date Updated -16/05/2005

i02350265

### Flywheel - Install

SMCS - 1156-012

### Installation Procedure (3003 Engine)

---

#### NOTICE

**Keep all parts clean from contaminants.**

**Contaminants may cause rapid wear and shortened component life.**

---

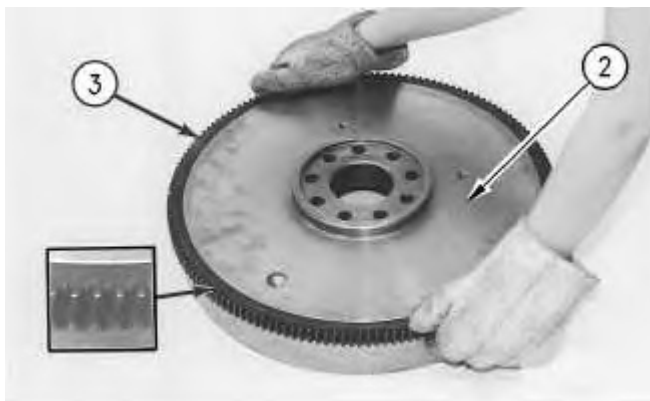

Illustration 1

g00596731

Typical example

1. Raise the temperature of flywheel ring gear (3) . Install flywheel ring gear (3) in the original position on flywheel (2) .

**Note:** The chamfered side of the gear teeth will be facing toward the starting motor when the flywheel is installed in order to ensure that the starting motor will engage correctly.

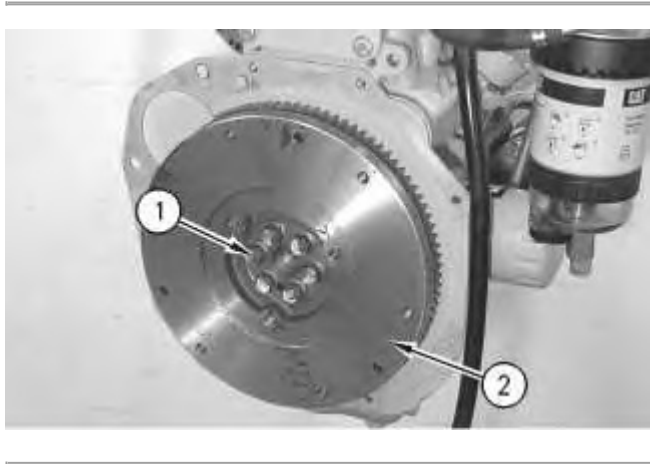

Illustration 2

g00582471

2. Position flywheel (2) on the rear of the engine.
3. Install bolts (1) and tighten the bolts to a torque of 73 N·m (54 lb ft).
4. Check the flywheel runout. Refer to Testing and Adjusting, "Flywheel - Inspect".

**End By:** Install the flywheel housing. Refer to Disassembly and Assembly, "Flywheel Housing - Remove and Install".

## Installation Procedure ( 3013, 3014 and 3024 Engines)

Table 1

Required Tools			
Tool	Part Number	Part Description	Qty
A	138-7573	Link Bracket	1
B	-	Guide Bolt (M10 x 1.25 mm)	2

### NOTICE

**Keep all parts clean from contaminants.**

**Contaminants may cause rapid wear and shortened component life.**

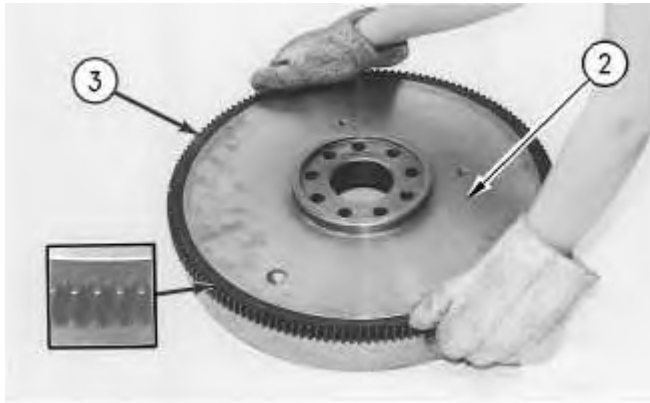

Illustration 3

g00596731

Typical example

1. Raise the temperature of flywheel ring gear (3) . Install flywheel ring gear (3) in the original position on flywheel (2) .

**Note:** The chamfered side of the gear teeth will be facing toward the starting motor when the flywheel is installed in order to ensure that the starting motor will engage correctly.

2. Attach Tooling (A) and a suitable lifting device to flywheel (2) . The weight of flywheel (2) is approximately 34 kg (75 lb).
3. Install Tooling (B) opposite each other in the end of the crankshaft.

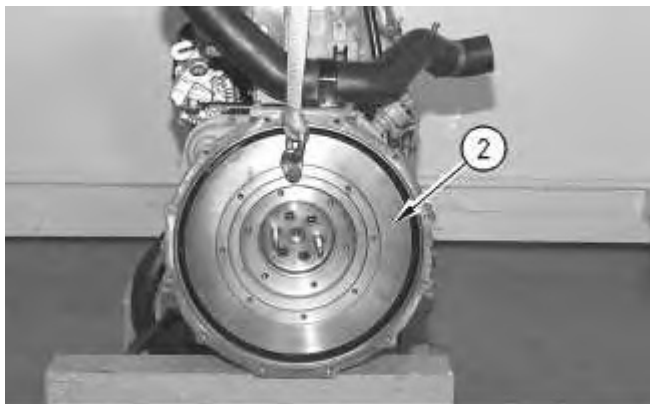
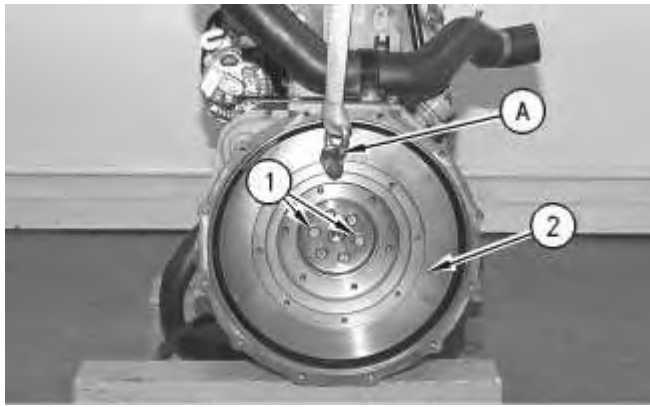

Illustration 4

g00584293

4. Position flywheel (2) on Tooling (B) . Ensure that the dowel pin on the crankshaft aligns with the dowel pin hole on the flywheel for proper installation.
-



---

Illustration 5

g00582825

5. Install bolts (1) .
6. Remove Tooling (B) and install remaining bolts (1) .
7. Tighten bolts (1) to a torque of 73 N·m (54 lb ft).
8. Remove Tooling (A) and the suitable lifting device from flywheel (2) .
9. Check the flywheel runout. Refer to Testing and Adjusting, "Flywheel - Inspect".

**End By:** Install the electric starting motor. Refer to Disassembly and Assembly, "Electric Starting Motor - Remove and Install".

---

Product: VIBRATORY COMPACTOR

Model: CB-224D VIBRATORY COMPACTOR 8RZ

Configuration: CB-214D CB-224D CB-225D Vibratory Compactors 8RZ00001-UP (MACHINE) POWERED BY 3013 Engine

## **Disassembly and Assembly 3003, 3013, 3014 and 3024 Engines for Caterpillar Built Machines**

Media Number -SEN5027-05

Publication Date -01/05/2005

Date Updated -16/05/2005

i01638277

# **Crankshaft Rear Seal - Remove**

SMCS - 1161-011

## **Removal Procedure**

### **Start By:**

- A. Remove the flywheel housing. Refer to Disassembly and Assembly, "Flywheel Housing - Remove and Install".

---

### **NOTICE**

**Keep all parts clean from contaminants.**

**Contaminants may cause rapid wear and shortened component life.**

---

---

### **NOTICE**

**Care must be taken to ensure that fluids are contained during performance of inspection, maintenance, testing, adjusting and repair of the product. Be prepared to collect the fluid with suitable containers before opening any compartment or disassembling any component containing fluids.**

**Refer to Special Publication, NENG2500, "Caterpillar Tools and Shop Products Guide" for tools and supplies suitable to collect and contain fluids on Caterpillar products.**

**Dispose of all fluids according to local regulations and mandates.**

---

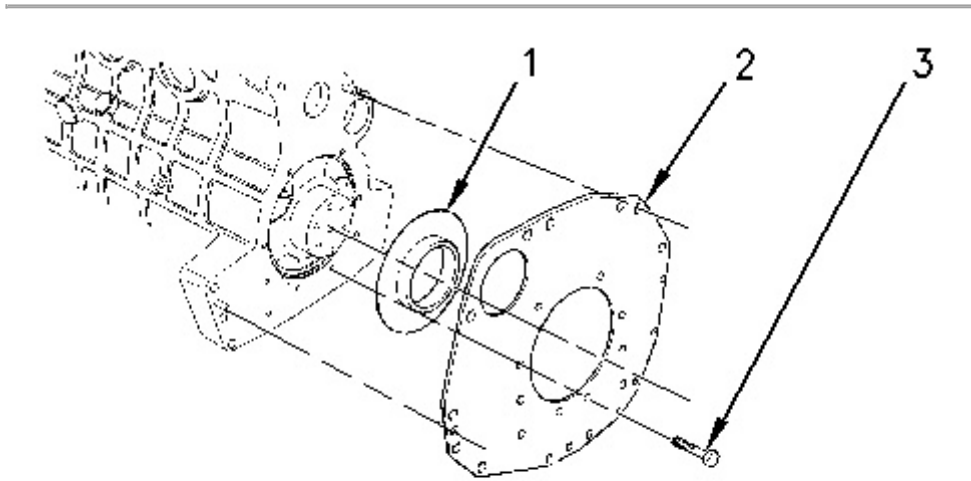

---

Illustration 1

g00847841

1. Remove bolts (3) and backplate (2) from the rear of the cylinder block.
  2. Remove crankshaft rear seal (1) from the cylinder block.
-



**Suggest:**

**For more complete manuals. Please go to the home page.**

**<https://www.ebooklibonline.com>**

**If the above button click is invalid. Please download this document first, and then click the above link to download the complete manual.**

**Thank you so much for reading**

Product: VIBRATORY COMPACTOR

Model: CB-224D VIBRATORY COMPACTOR 8RZ

Configuration: CB-214D CB-224D CB-225D Vibratory Compactors 8RZ00001-UP (MACHINE) POWERED BY 3013 Engine

## **Disassembly and Assembly 3003, 3013, 3014 and 3024 Engines for Caterpillar Built Machines**

Media Number -SEN5027-05

Publication Date -01/05/2005

Date Updated -16/05/2005

i01099295

# **Crankshaft Rear Seal - Install**

SMCS - 1161-012

## **Installation Procedure**

---

### **NOTICE**

**Keep all parts clean from contaminants.**

**Contaminants may cause rapid wear and shortened component life.**

---

1. Clean the back of the cylinder block and the mating surface of the backplate.



Illustration 1

g00578148

2. Install crankshaft rear seal (3) on the cylinder block.

3. Put a bead of **4C-9612** Silicone Sealant around the bolt holes and the face of the cylinder block.

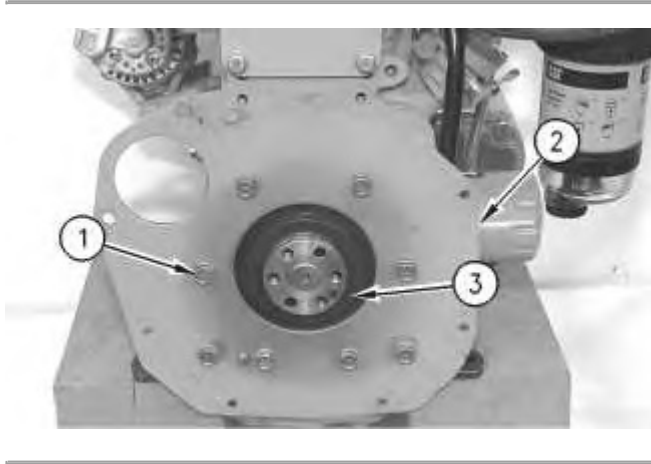

Illustration 2

g00578100

4. Position backplate (2) on the rear of the engine.
5. Install bolts (1) that fasten backplate (2) on the engine. Tighten the bolts to the following torque:

3003 Engine ... 50 N·m (37 lb ft)

3013, 3014 and 3024 Engines ... 15 N·m (11 lb ft)

**End By:** Install the flywheel housing. Refer to Disassembly and Assembly, "Flywheel Housing - Remove and Install".

---

**<https://www.ebooklibonline.com>**

Hello dear friend!

Thank you very much for reading.

Enter the link into your browser.

The full manual is available for immediate download.

**<https://www.ebooklibonline.com>**