

Product: VIBRATORY COMPACTOR

Model: CB-214E VIBRATORY COMPACTOR 214

Configuration: CB-214E,CB-224E,CB-225E Vibratory Compactor 21400001-UP (MACHINE) POWERED BY 3013C Engine

## **Disassembly and Assembly 3003, 3013, 3014 and 3024 Engines for Caterpillar Built Machines**

Media Number -SEN5027-05

Publication Date -01/05/2005

Date Updated -16/05/2005

i04583132

# **Fuel Injection Pump - Remove**

SMCS - 1251-011

## **Removal Procedure**

### **Start By:**

- A. Remove the fuel injection lines. Refer to Disassembly and Assembly, "Fuel Injection Lines - Remove and Install".
- B. If necessary, remove the fuel shutoff solenoid. Refer to Disassembly and Assembly, "Fuel Shutoff Solenoid - Remove and Install".

---

### **NOTICE**

**Keep all parts clean from contaminants.**

**Contaminants may cause rapid wear and shortened component life.**

---

---

### **NOTICE**

**Care must be taken to ensure that fluids are contained during performance of inspection, maintenance, testing, adjusting, and repair of the product. Be prepared to collect the fluid with suitable containers before opening any compartment or disassembling any component containing fluids.**

**Refer to Special Publication, NENG2500, "Dealer Service Tool Catalog" for tools and supplies suitable to collect and contain fluids on Cat products.**

Dispose of all fluids according to local regulations and mandates.

---

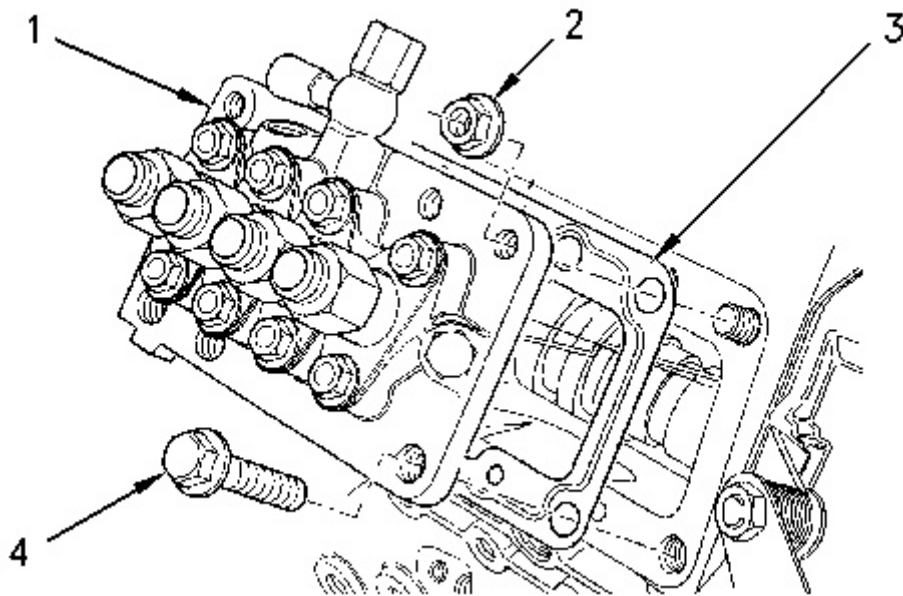

Illustration 1

g00825132

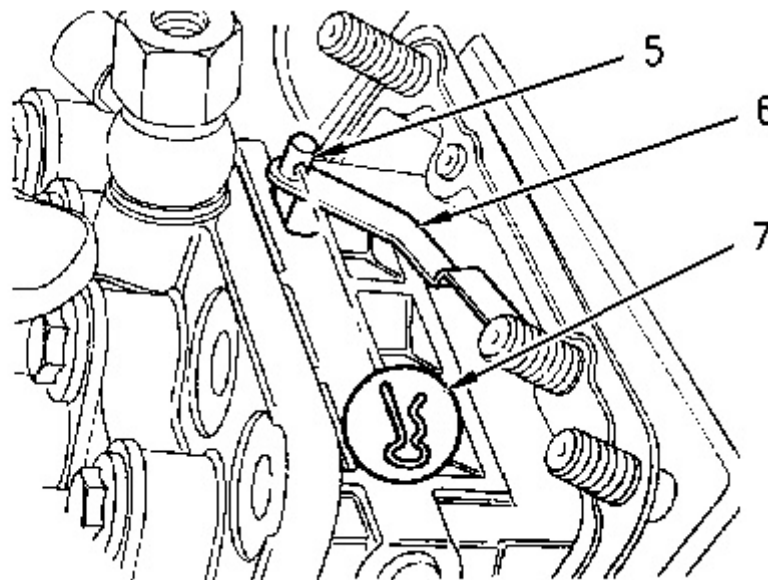

Illustration 2

g00825137

1. Remove bolts (4) and nuts (2) that fasten the fuel injection pump to the cylinder block.
2. Carefully raise fuel injection pump (1) from the cylinder block and remove clip (7) that connects link (6) to fuel rack control (5) .

3. Remove fuel injection pump (1) from the cylinder block.

**Note:** Record the thickness of each shim and the number of shims for reassembly. The fuel injection timing is determined by the shim pack thickness that is between the fuel injection pump and the mounting face on the cylinder block. For more information on the fuel injection pump, refer to Specifications, "Fuel Injection Pump".

4. Remove shims (3) from the mounting plate.

---

**<https://www.ebooklibonline.com>**

Hello dear friend!

Thank you very much for reading.

Enter the link into your browser.

The full manual is available for immediate download.

**<https://www.ebooklibonline.com>**

Product: VIBRATORY COMPACTOR

Model: CB-214E VIBRATORY COMPACTOR 214

Configuration: CB-214E,CB-224E,CB-225E Vibratory Compactor 21400001-UP (MACHINE) POWERED BY 3013C Engine

## **Disassembly and Assembly 3003, 3013, 3014 and 3024 Engines for Caterpillar Built Machines**

Media Number -SEN5027-05

Publication Date -01/05/2005

Date Updated -16/05/2005

i01591134

# **Fuel Injection Pump - Install**

SMCS - 1251-012

## **Installation Procedure**

---

### **NOTICE**

**Keep all parts clean from contaminants.**

**Contaminants may cause rapid wear and shortened component life.**

---

---

### **NOTICE**

**Care must be taken to ensure that fluids are contained during performance of inspection, maintenance, testing, adjusting and repair of the product. Be prepared to collect the fluid with suitable containers before opening any compartment or disassembling any component containing fluids.**

**Refer to Special Publication, NENG2500, "Caterpillar Tools and Shop Products Guide" for tools and supplies suitable to collect and contain fluids on Caterpillar products.**

**Dispose of all fluids according to local regulations and mandates.**

---

---

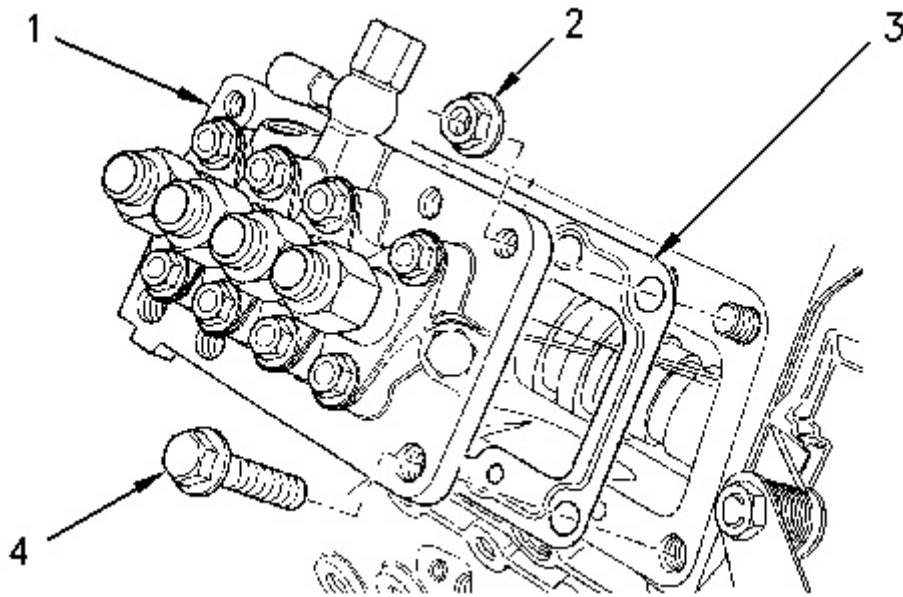

Illustration 1

g00825132

1. Position the correct number of shims (3) on the mounting face of the cylinder block. Refer to Specifications, "Fuel Injection Pump".

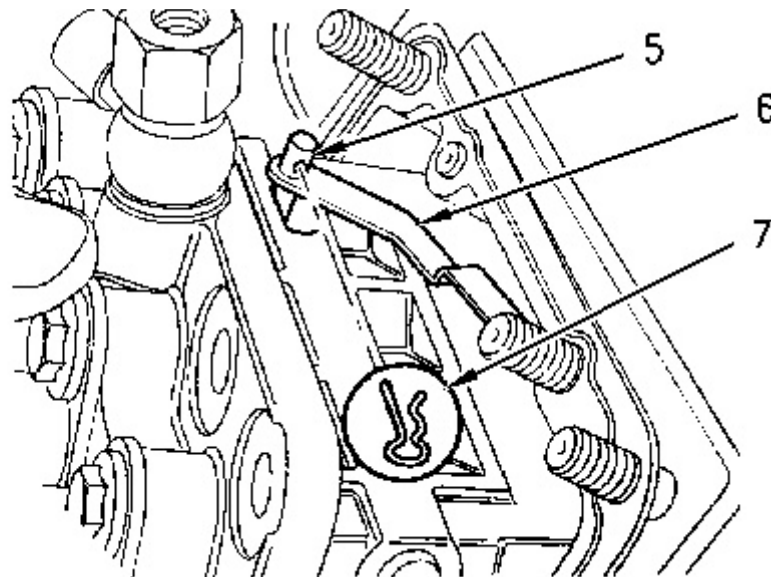

Illustration 2

g00825137

2. Position fuel injection pump (1) close to the mounting face of the cylinder block, and connect link (6) and fuel rack control (5) with clip (7) .
3. Put fuel injection pump (1) in position on the mounting face of the cylinder block.
4. Install bolts (4) and nuts (2) that fasten the fuel injection pump to the cylinder block. Tighten bolts (4) and nuts (2) to the following torque.

3003 Engine ... 6 N·m (4 lb ft)

3013, 3014, and 3024 Engines ... 15 N·m (11 lb ft)

3024C Engine ... 15 N·m (11 lb ft)

**End By:**

- a. Install the fuel shutoff solenoid. Refer to Disassembly and Assembly, "Fuel Shutoff Solenoid - Remove and Install".
  - b. Install the fuel injection lines. Refer to Disassembly and Assembly, "Fuel Injection Lines - Remove and Install".
-

Product: VIBRATORY COMPACTOR

Model: CB-214E VIBRATORY COMPACTOR 214

Configuration: CB-214E,CB-224E,CB-225E Vibratory Compactor 21400001-UP (MACHINE) POWERED BY 3013C Engine

## Disassembly and Assembly 3003, 3013, 3014 and 3024 Engines for Caterpillar Built Machines

Media Number -SEN5027-05

Publication Date -01/05/2005

Date Updated -16/05/2005

i01893805

# Exhaust Manifold - Remove and Install

SMCS - 1059-010

## Removal Procedure

---

### NOTICE

**Keep all parts clean from contaminants.**

**Contaminants may cause rapid wear and shortened component life.**

---

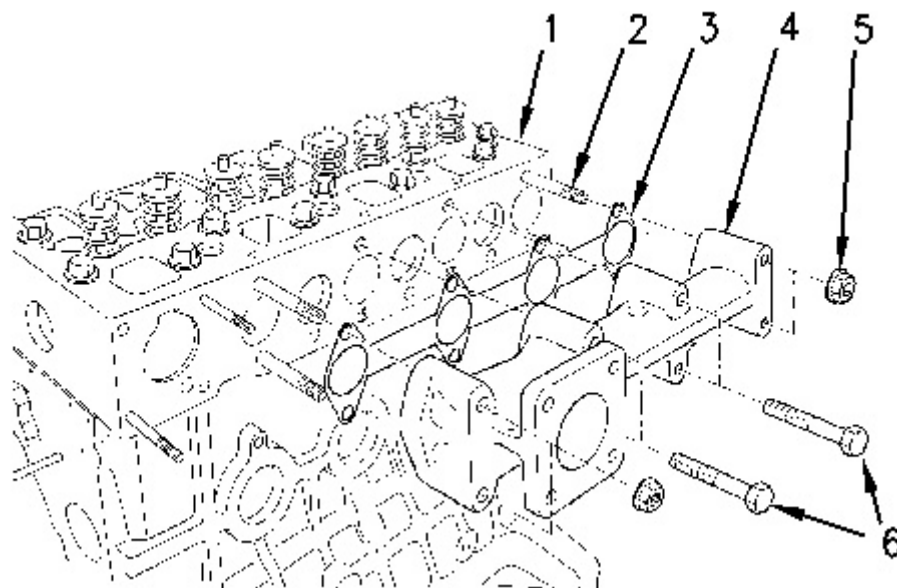

Typical example

1. Remove exhaust manifold nuts (5) and bolts (6) .
2. Remove exhaust manifold (4) from the cylinder head (1) .
3. Remove gasket (3) from the cylinder head.
4. Remove any remaining gasket material and carbon from the cylinder head and the exhaust manifold. Be careful not to damage the mating surface on the cylinder head for the exhaust manifold.
5. Remove studs (2) for exhaust manifold (4) from cylinder head (1) .

## Installation Procedure

---

### NOTICE

**Keep all parts clean from contaminants.**

**Contaminants may cause rapid wear and shortened component life.**

---

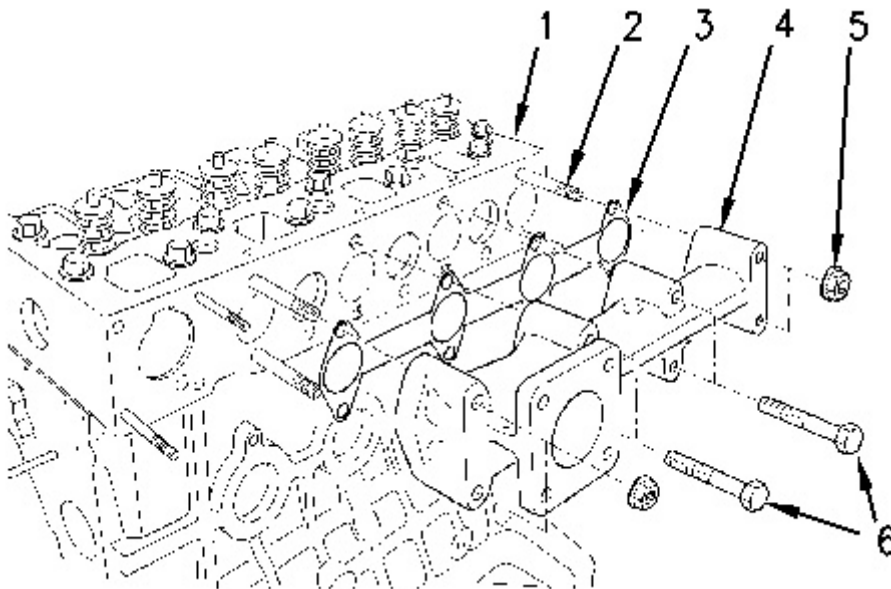

Typical example

1. If studs (2) were removed during disassembly, install attaching studs (2) to cylinder head (1) .
2. Put a new exhaust manifold gasket (3) in position on cylinder head (1) .

**Note:** Do not use any sealant on the exhaust manifold gasket.

3. Put exhaust manifold (4) in position on cylinder head (1) .
4. Install exhaust manifold nuts (5) and bolts (6) .

For 3013C Engines and 3024C Engines, tighten nuts (5) and bolts (6) to a torque of 25 N·m (18 lb ft).

For 3011C Engines, tighten nuts (5) and bolts (6) to a torque of 10 N·m (89 lb in).

**Note:** Tighten the two inner bolts first on three cylinder engines. Tighten the four inner bolts first on four cylinder engines. Then tighten the two outer bolts and the two nuts. Ensure that the bolts with different lengths are installed in the correct holes.

---

Product: VIBRATORY COMPACTOR

Model: CB-214E VIBRATORY COMPACTOR 214

Configuration: CB-214E,CB-224E,CB-225E Vibratory Compactor 21400001-UP (MACHINE) POWERED BY 3013C Engine

## **Disassembly and Assembly 3003, 3013, 3014 and 3024 Engines for Caterpillar Built Machines**

Media Number -SEN5027-05

Publication Date -01/05/2005

Date Updated -16/05/2005

i01481961

# **Inlet Manifold - Remove - 3013, 3014, and 3024 Engines**

SMCS - 1058-011

S/N - 2141-UP

S/N - 3TW1-UP

S/N - 4AZ1-UP

S/N - 4CZ1-UP

S/N - 4HW1-UP

S/N - 4ZW1-UP

S/N - 7ES1-UP

S/N - 8FG1-UP

S/N - 9TJ1-UP

S/N - AFW1-UP

S/N - ANR1-UP

S/N - CSS1-UP

## **Removal Procedure**

---

### **NOTICE**

**Keep all parts clean from contaminants.**

**Contaminants may cause rapid wear and shortened component life.**

---

## **NOTICE**

**Care must be taken to ensure that fluids are contained during performance of inspection, maintenance, testing, adjusting and repair of the product. Be prepared to collect the fluid with suitable containers before opening any compartment or disassembling any component containing fluids.**

**Refer to Special Publication, NENG2500, "Caterpillar Tools and Shop Products Guide" for tools and supplies suitable to collect and contain fluids on Caterpillar products.**

**Dispose of all fluids according to local regulations and mandates.**

---

**Note:** The inlet manifold that is used on the 3013, 3014, and 3024 Engines is removable as a separate part. The inlet manifold on the 3003 Engine is part of the valve mechanism cover.

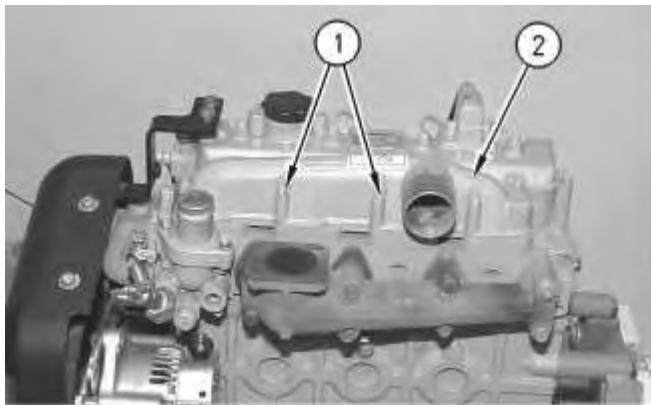
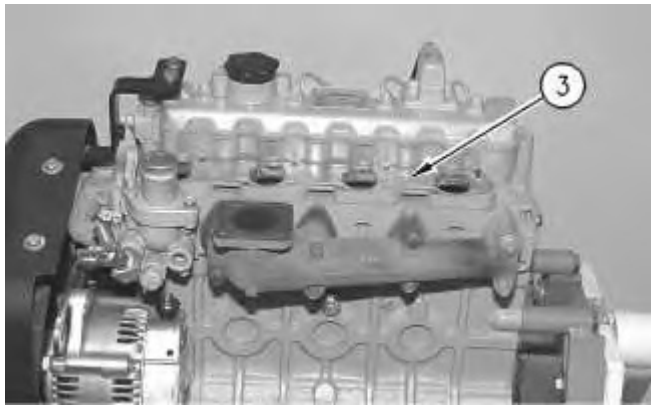

Illustration 1

g00592847

1. Remove bolts (1) and inlet manifold (2) from the cylinder head.
  2. Remove the gasket for the inlet manifold from the spacer plate.
-



---

Illustration 2

g00592858

3. Remove spacer plate (3) for the inlet manifold.

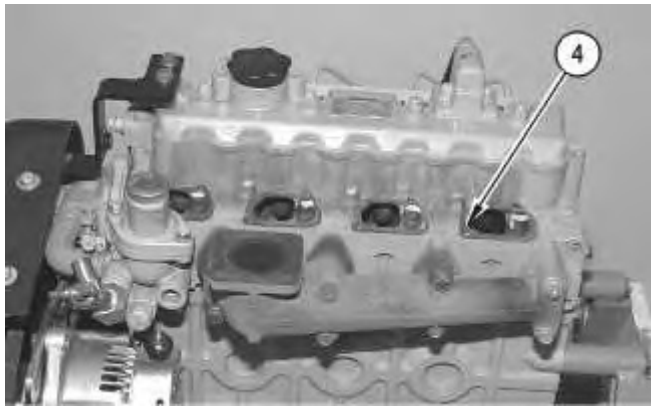

---

Illustration 3

g00592865

4. Remove spacer plate gasket (4) for the inlet manifold from the cylinder head.
-

Product: VIBRATORY COMPACTOR

Model: CB-214E VIBRATORY COMPACTOR 214

Configuration: CB-214E,CB-224E,CB-225E Vibratory Compactor 21400001-UP (MACHINE) POWERED BY 3013C Engine

## **Disassembly and Assembly 3003, 3013, 3014 and 3024 Engines for Caterpillar Built Machines**

Media Number -SEN5027-05

Publication Date -01/05/2005

Date Updated -16/05/2005

i01472822

## **Inlet Manifold - Install - 3013, 3014, and 3024 Engines**

SMCS - 1058-012

S/N - 2141-UP

S/N - 3TW1-UP

S/N - 4AZ1-UP

S/N - 4CZ1-UP

S/N - 4HW1-UP

S/N - 4ZW1-UP

S/N - 7ES1-UP

S/N - 8FG1-UP

S/N - 9TJ1-UP

S/N - AFW1-UP

S/N - ANR1-UP

S/N - CSS1-UP

## **Installation Procedure**

---

### **NOTICE**

**Keep all parts clean from contaminants.**

**Contaminants may cause rapid wear and shortened component life.**

---

**Note:** The inlet manifold that is used on the 3013, 3014 and 3024 Engines is removable as a separate part. The inlet manifold on the 3003 engine is part of the valve mechanism cover.

1. Clean the cylinder head surface and the spacer plate for the inlet manifold. Ensure that no debris or gasket material is remaining on the mating surfaces.

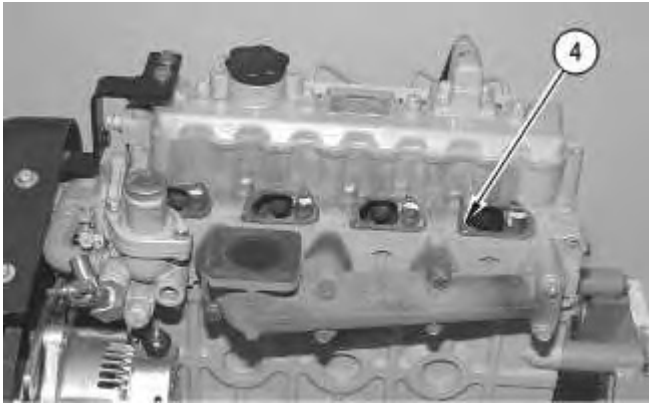

Illustration 1

g00592865

2. Install new spacer plate gasket (4) for the inlet manifold on the cylinder head.

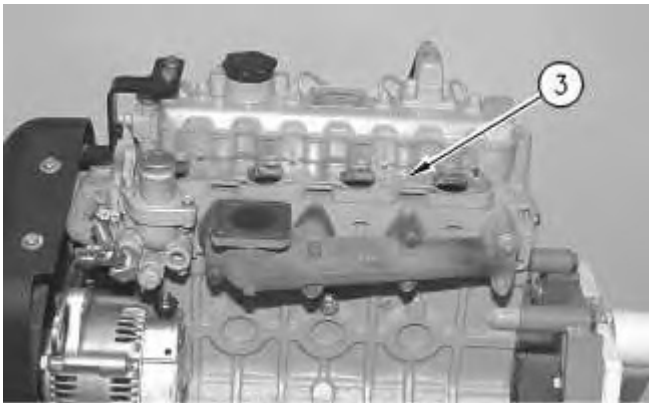
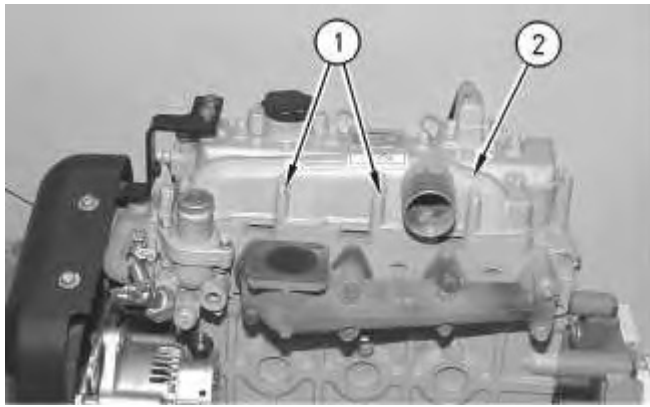

Illustration 2

g00592858

3. Install spacer plate (3) for the inlet manifold.
-



---

Illustration 3

g00592847

4. Install a new gasket for the inlet manifold and position inlet manifold (2) on the cylinder head.
5. Install bolts (1) that fasten the inlet manifold to the cylinder head and tighten bolts (1) to the following torque:

3013 Engine ... 10 N·m (90 lb in)

3014 and 3024 Engines ... 14 N·m (10 lb ft)

---

Product: VIBRATORY COMPACTOR

Model: CB-214E VIBRATORY COMPACTOR 214

Configuration: CB-214E,CB-224E,CB-225E Vibratory Compactor 21400001-UP (MACHINE) POWERED BY 3013C Engine

## Disassembly and Assembly 3003, 3013, 3014 and 3024 Engines for Caterpillar Built Machines

Media Number -SEN5027-05

Publication Date -01/05/2005

Date Updated -16/05/2005

i02399171

# Inlet and Exhaust Valve Springs - Remove and Install

SMCS - 1108-010

## Removal Procedure

Table 1

Required Tools			
Tool	Part Number	Part Description	Qty
A	9U-6195	Valve Spring Compressor	1

### Start By:

- A. Remove the rocker shaft. Refer to Disassembly and Assembly, "Rocker Shaft and Pushrod - Remove".

---

### NOTICE

**Keep all parts clean from contaminants.**

**Contaminants may cause rapid wear and shortened component life.**

---

**Note:** Before you begin the removal of the valve springs, refer to Specifications, "Cylinder Head Valves" and Testing and Adjusting, "Cylinder Head - Inspect" for appropriate information on the valve springs.

---

### NOTICE

**Do not turn the crankshaft while the valve springs are removed.**

- 
1. Ensure that the piston is at the top center position.
- 

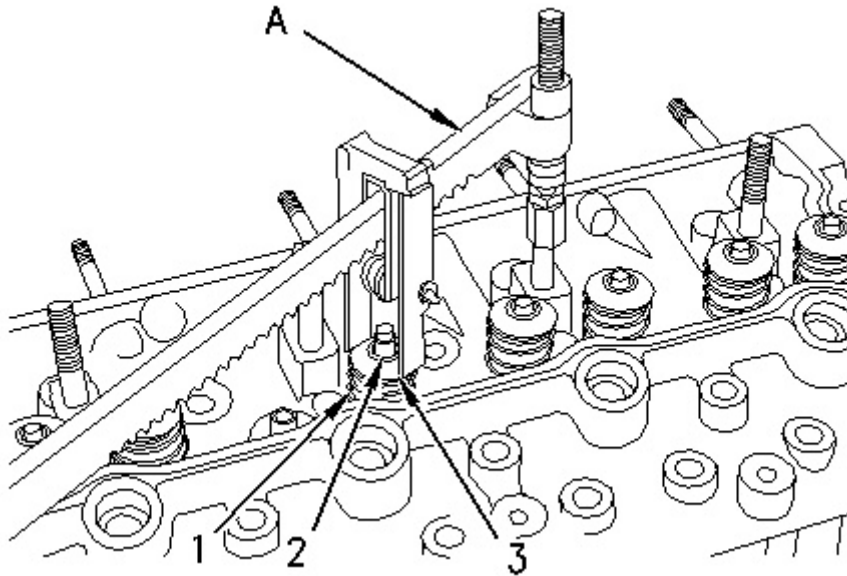

---

Illustration 1

g00825744

**⚠ WARNING**

**Personal injury can result from parts and/or covers under spring pressure.**

**Spring force will be released when covers are removed.**

**Be prepared to hold spring loaded covers as the bolts are loosened.**

---

2. Use Tooling (A) to compress valve springs (1) . Remove valve keepers (2) .
- 

**NOTICE**

**Ensure that the valve spring is compressed squarely or damage to the valve stem may occur.**

---

3. Release the pressure on Tooling (A) . Remove valve spring retainer (3) and valve springs (1) from the cylinder head.

---

## NOTICE

**Do not turn the crankshaft while the valve springs are removed.**

---

## Installation Procedure

Table 2

Required Tools			
Tool	Part Number	Part Description	Qty
A	9U-6195	Valve Spring Compressor	1

---

## NOTICE

**Keep all parts clean from contaminants.**

**Contaminants may cause rapid wear and shortened component life.**

---

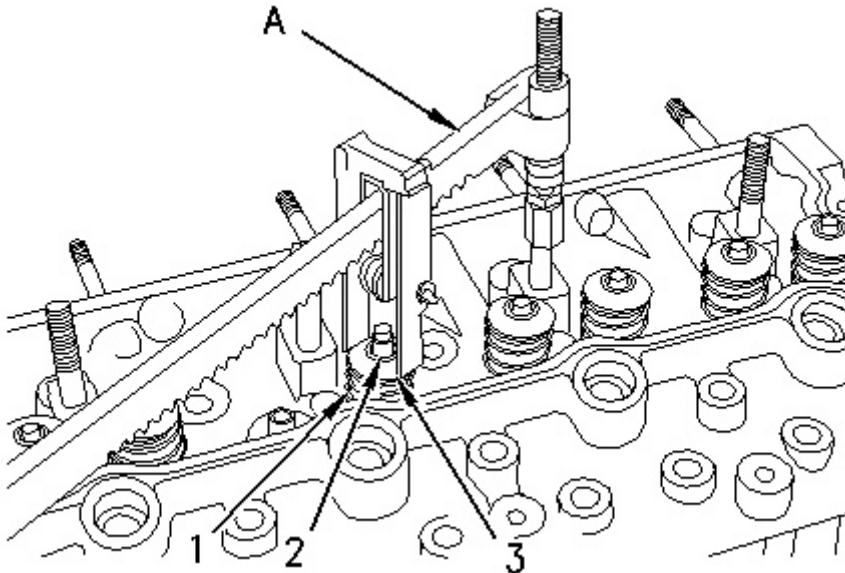

Illustration 2

g00825744

 **WARNING**

**Improper assembly of parts that are spring loaded can cause bodily injury.**

**To prevent possible injury, follow the established assembly procedure and wear protective equipment.**

---

1. Place new valve springs (1) into position on the cylinder head.

**Note:** Ensure that the closed damper coils are toward the cylinder head if double valve springs are used.

2. Install valve spring retainer (3) .
3. Use Tooling (A) to compress valve springs (1) .

---

### **NOTICE**

**Ensure that the valve spring is compressed squarely or damage to the valve stem may occur.**

---

4. Install valve keepers (2) in order to lock the valve springs in position.
5. Release the pressure slowly on Tooling (A) . Remove Tooling (A) . Strike the top of the valves with a soft faced hammer in order to ensure that the valve keepers are properly installed.

**End By:** Install the rocker shaft. Refer to Disassembly and Assembly, "Rocker Shaft and Pushrod - Install".

---

Product: VIBRATORY COMPACTOR

Model: CB-214E VIBRATORY COMPACTOR 214

Configuration: CB-214E,CB-224E,CB-225E Vibratory Compactor 21400001-UP (MACHINE) POWERED BY 3013C Engine

## Disassembly and Assembly 3003, 3013, 3014 and 3024 Engines for Caterpillar Built Machines

Media Number -SEN5027-05

Publication Date -01/05/2005

Date Updated -16/05/2005

i02015360

# Inlet and Exhaust Valves - Remove and Install

SMCS - 1105-010

## Removal Procedure

Table 1

Required Tools			
Tool	Part Number	Part Description	Qty
A	9U-6195	Valve Spring Compressor	1

### Start By:

- A. Remove the cylinder head. Refer to Disassembly and Assembly, "Cylinder Head - Remove".

---

### NOTICE

**Keep all parts clean from contaminants.**

**Contaminants may cause rapid wear and shortened component life.**

---

1. Clean the bottom face of the cylinder head. Use a dial indicator to check the depth of the valves below the face of the cylinder head before the valve springs are removed. Refer to the Specifications, "Cylinder Head Valves" for the correct dimensions.
  2. Place an index mark on the heads of the inlet valves and the exhaust valves for installation purposes.
-

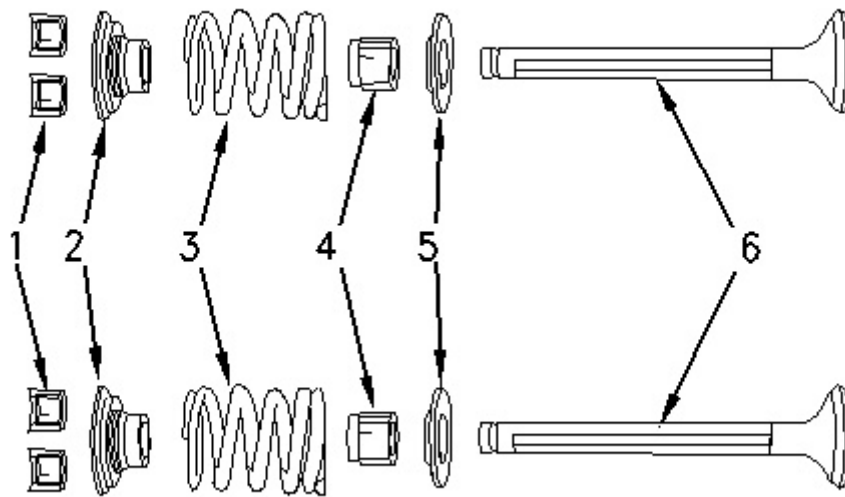

Illustration 1

g00659252

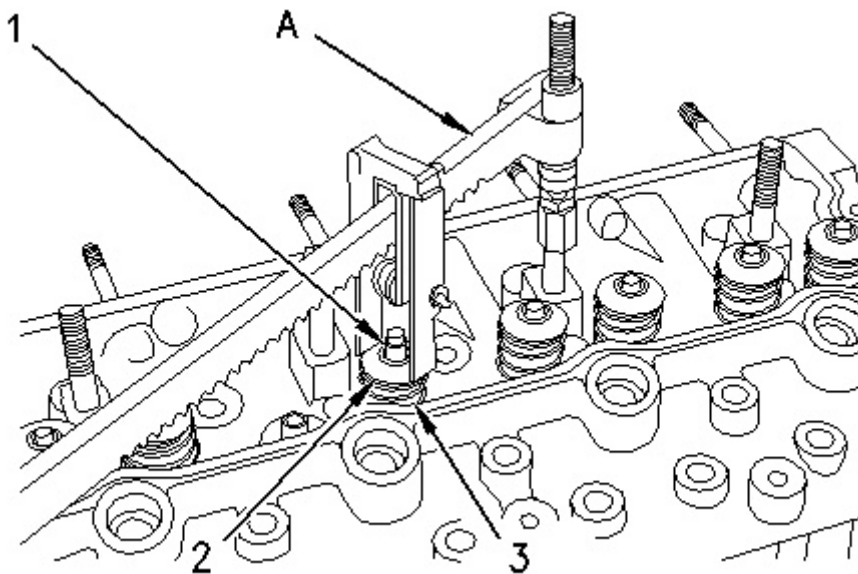

Illustration 2

g00825746

**⚠ WARNING**

The valve spring keepers can be thrown from the valve when the valve spring compressor is released. Ensure that the valve spring keepers are properly installed on the valve stem. To help prevent personal injury, keep away from the front of the valve spring keepers and valve springs during the installation of the valves.

3. Use Tooling (A) to compress valve springs (3) .
4. Remove two valve keepers (1) .
5. Slowly release the pressure on Tooling (A) and remove Tooling (A) .
6. Remove valve spring retainers (2) .
7. Remove valve springs (3) .
8. Remove valve stem seals (4) .
9. Remove valve spring seat washers (5) .
10. Remove inlet valves (6) and exhaust valves (6) .

## Removal Procedure (Alternate Method)

Table 2

<b>Required Tools</b>			
<b>Tool</b>	<b>Part Number</b>	<b>Part Description</b>	<b>Qty</b>
B	5S-1330	Valve Spring Compressor	1

Follow the instructions above using Tooling (B) .

## Installation Procedure

Table 3

<b>Required Tools</b>			
<b>Tool</b>	<b>Part Number</b>	<b>Part Description</b>	<b>Qty</b>
A	9U-6195	Valve Spring Compressor	1

---

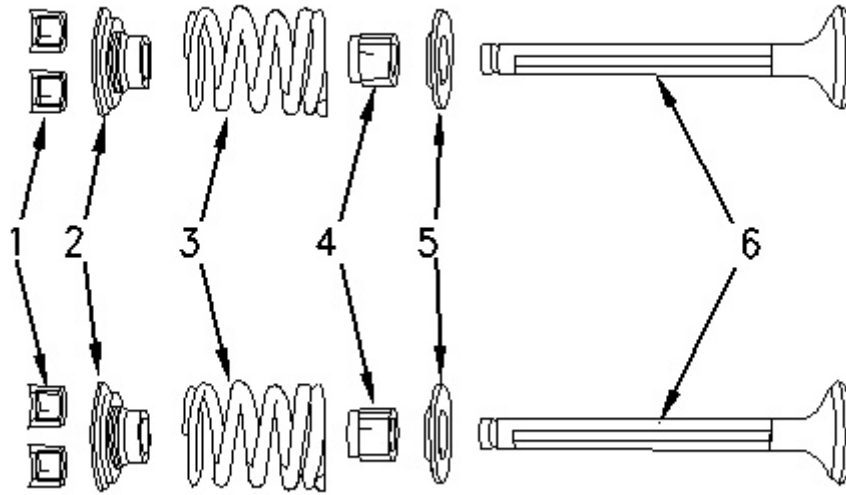

Illustration 3

g00659252

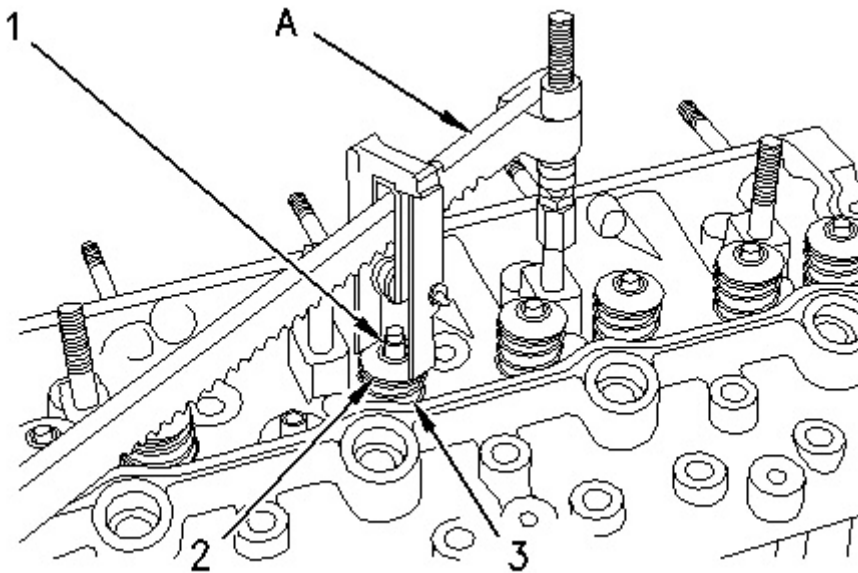

Illustration 4

g00825746

## NOTICE

**Keep all parts clean from contaminants.**

**Contaminants may cause rapid wear and shortened component life.**

## **WARNING**

**The valve spring keepers can be thrown from the valve when the valve spring compressor is released. Ensure that the valve spring keepers are properly installed on the valve stem. To help prevent personal injury, keep away from the front of the valve spring keepers and valve springs during the installation of the valves.**

1. Lubricate the stems of inlet valves (6) and the stems of exhaust valves (6) with clean engine oil.
2. Install inlet valves (6) and exhaust valves (6) in the respective positions.
3. Install valve spring seat washers (5) .
4. Install new valve stem seals (4) .
5. Install valve springs (3) .

**Note:** Install valve springs (3) on the valve spring seat washers. This is done with double valve springs.

6. Install valve spring retainers (2) .
7. Use Tooling (A) to compress valve springs (3) .
8. Install valve keepers (1) .
9. Slowly release the pressure on Tooling (A) and remove Tooling (A). Strike the top of the valves with a soft hammer in order to ensure that the valve keepers are properly installed.

**Note:** Refer to Specifications, "Cylinder Head Valves" for more information on the inlet valves and the exhaust valves.

10. Use a dial indicator to check the depth of the new valves below the cylinder head. If the depth of the new valves is below the correct depth, the valve seat inserts must be replaced.

**End By:** Install the cylinder head. Refer to Disassembly and Assembly, "Cylinder Head - Install".

## **Installation Procedure (Alternate Method)**

Table 4

<b>Required Tools</b>			
<b>Tool</b>	<b>Part Number</b>	<b>Part Description</b>	<b>Qty</b>
B	5S-1330	Valve Spring Compressor	1

Follow the procedure above using Tooling (B).

Product: VIBRATORY COMPACTOR

Model: CB-214E VIBRATORY COMPACTOR 214

Configuration: CB-214E,CB-224E,CB-225E Vibratory Compactor 21400001-UP (MACHINE) POWERED BY 3013C Engine

## **Disassembly and Assembly**

### **3003, 3013, 3014 and 3024 Engines for Caterpillar Built Machines**

Media Number -SEN5027-05

Publication Date -01/05/2005

Date Updated -16/05/2005

i01591441

## **Engine Oil Relief Valve - Remove and Install**

SMCS - 1315-010

### **Removal Procedure**

---

#### **NOTICE**

**Keep all parts clean from contaminants.**

**Contaminants may cause rapid wear and shortened component life.**

---

---

#### **NOTICE**

**Care must be taken to ensure that fluids are contained during performance of inspection, maintenance, testing, adjusting and repair of the product. Be prepared to collect the fluid with suitable containers before opening any compartment or disassembling any component containing fluids.**

**Refer to Special Publication, NENG2500, "Caterpillar Tools and Shop Products Guide" for tools and supplies suitable to collect and contain fluids on Caterpillar products.**

**Dispose of all fluids according to local regulations and mandates.**

---

---

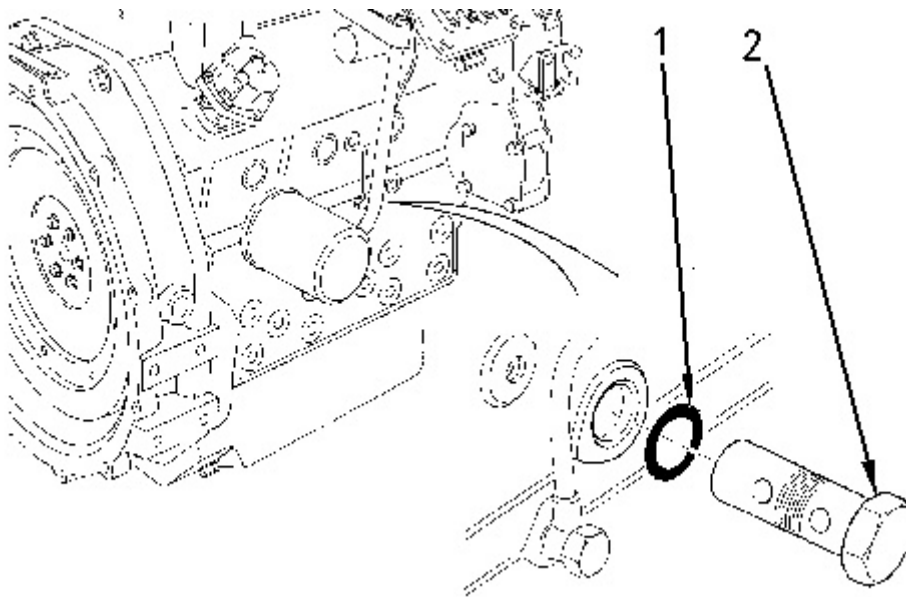

---

Illustration 1

g00820218

1. Remove engine oil relief valve (2) from the cylinder block.
2. Remove O-ring seal (1) from the engine oil relief valve.

## Installation Procedure

---

### NOTICE

**Keep all parts clean from contaminants.**

**Contaminants may cause rapid wear and shortened component life.**

---

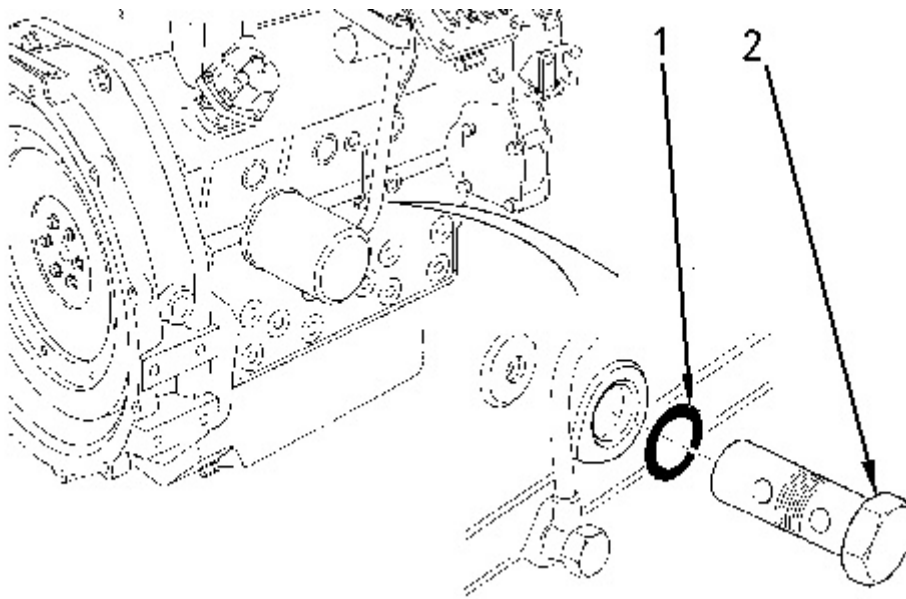

---

Illustration 2

g00820218

1. Install new O-ring seal (1) on engine oil relief valve (2) .
  2. Lubricate engine oil relief valve (2) with clean engine oil.
  3. Install engine oil relief valve (2) in the cylinder block. Tighten the engine oil relief valve to a torque of 64 N·m (47 lb ft).
-

Product: VIBRATORY COMPACTOR

Model: CB-214E VIBRATORY COMPACTOR 214

Configuration: CB-214E,CB-224E,CB-225E Vibratory Compactor 21400001-UP (MACHINE) POWERED BY 3013C Engine

## **Disassembly and Assembly 3003, 3013, 3014 and 3024 Engines for Caterpillar Built Machines**

Media Number -SEN5027-05

Publication Date -01/05/2005

Date Updated -16/05/2005

i02399591

# **Engine Oil Pump - Remove**

SMCS - 1304-011

## **Removal Procedure**

### **Start By:**

- A. Remove the engine oil pan. Refer to Disassembly and Assembly, "Engine Oil Pan - Remove and Install".
- B. Remove the front housing. Refer to Disassembly and Assembly, "Housing (Front) - Remove".

---

### **NOTICE**

**Keep all parts clean from contaminants.**

**Contaminants may cause rapid wear and shortened component life.**

---

---

### **NOTICE**

**If the front housing is not installed, do not turn the crankshaft.  
Damage to the engine may occur.**

---

---

### **NOTICE**

Care must be taken to ensure that fluids are contained during performance of inspection, maintenance, testing, adjusting and repair of the product. Be prepared to collect the fluid with suitable containers before opening any compartment or disassembling any component containing fluids.

Refer to Special Publication, NENG2500, "Caterpillar Dealer Service Tool Catalog" for tools and supplies suitable to collect and contain fluids on Caterpillar products.

Dispose of all fluids according to local regulations and mandates.

---

## Engine Oil Pump

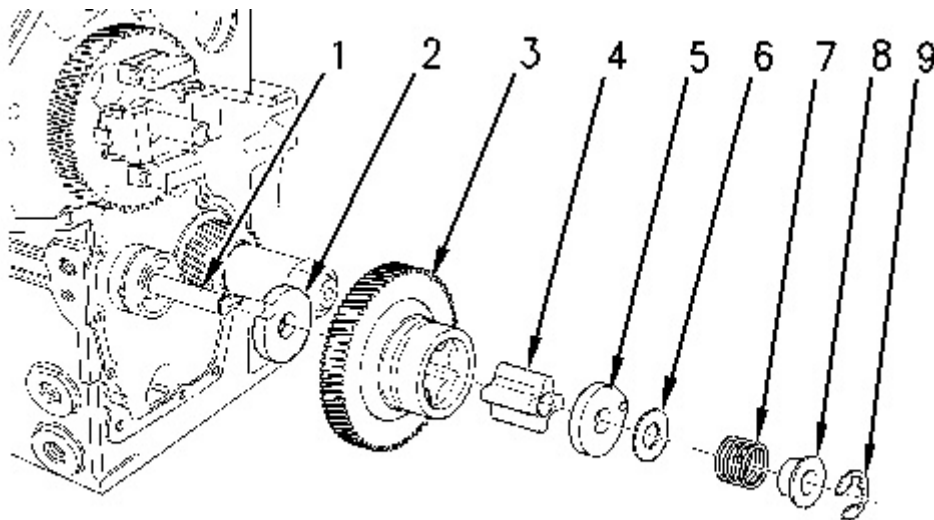

---

Illustration 1

g00825411

### **WARNING**

Personal injury can result from being struck by parts propelled by a released spring force.

Make sure to wear all necessary protective equipment.

Follow the recommended procedure and use all recommended tooling to release the spring force.

---



**Suggest:**

**For more complete manuals. Please go to the home page.**

**<https://www.ebooklibonline.com>**

**If the above button click is invalid. Please download this document first, and then click the above link to download the complete manual.**

**Thank you so much for reading**

1. Remove retaining ring (9) that retains idler gear (3) on idler hub (1) .
  2. Remove the following items from idler hub (1) :
    - Collar (8)
    - Spring (7)
    - Shim (6)
    - Oil pump cover (5)
    - Inner rotor (4)
  3. Remove idler gear (3) from idler hub (1) .
  4. Remove thrust washer (2) from idler hub (1) .
  5. Inspect all the components for wear or damage. If components are worn or damaged, use new parts for replacement.
- Note:** Refer to Specifications, "Engine Oil Pump" for more information.
6. If the engine oil pump has excessive buildup of sludge, inspect the oil strainer. The oil strainer can be removed by using the following procedure:
    - a. Remove the engine oil pan. Refer to Disassembly and Assembly, "Engine Oil Pan - Remove and Install".

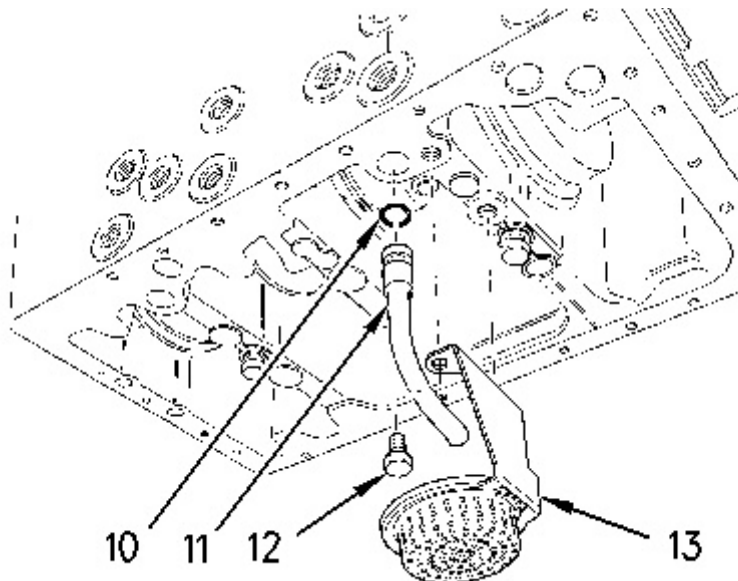

Illustration 2

g00825406

- b. Remove bolts (12) and oil strainer (13) from the cylinder block. Inspect the oil strainer for damage. If the oil strainer is damaged, use a new part for replacement.
- c. Remove tube assembly (11) from the cylinder block.

- d. Remove O-ring seal (10) from the tube assembly. Inspect the O-ring seal for wear or damage. If the O-ring seal is worn or damaged, use a new part for replacement.

## Idler Hub

Table 1

Required Tools			
Tool	Part Number	Part Description	Qty
A	1P-0074	Slide Hammer Puller	1

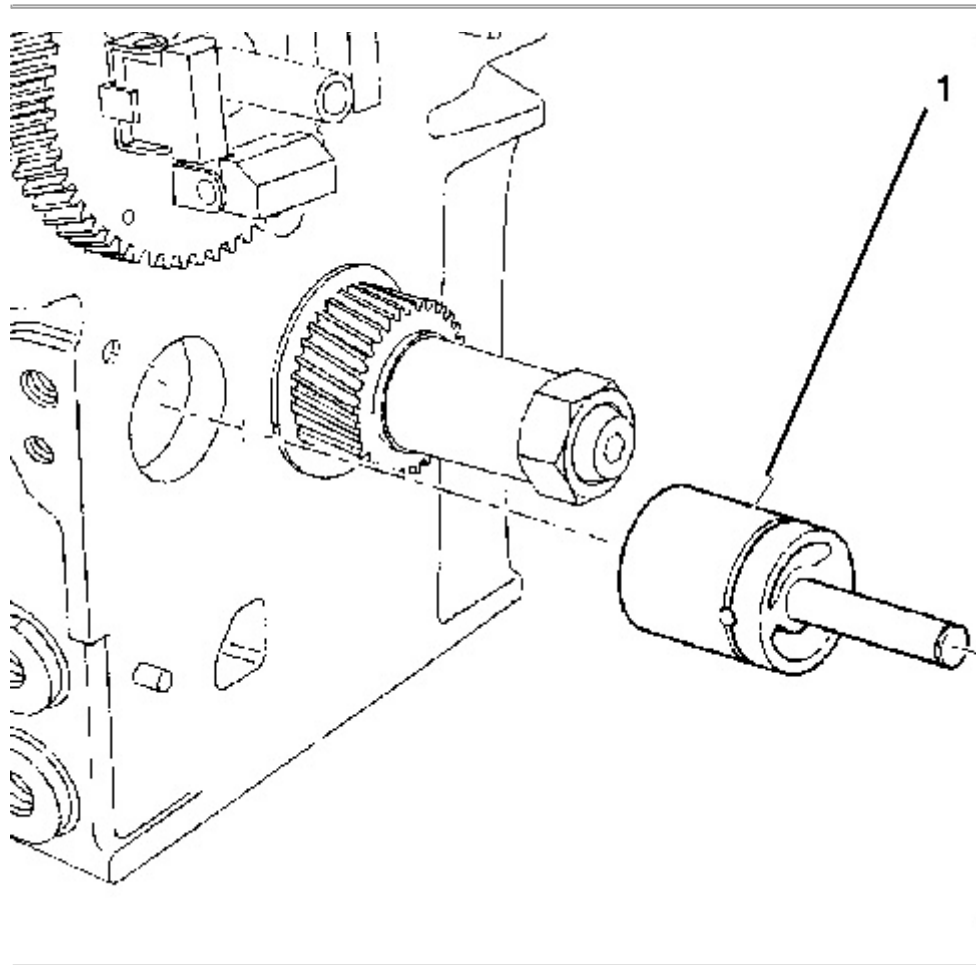

Illustration 3

g01037604

1. Use Tooling (A) to remove idler hub (1) from the cylinder block.

**<https://www.ebooklibonline.com>**

Hello dear friend!

Thank you very much for reading.

Enter the link into your browser.

The full manual is available for immediate download.

**<https://www.ebooklibonline.com>**