

Product: WHEEL LOADER

Model: 908M WHEEL LOADER Z88

Configuration: 908M Compact Wheel Loader Z8800001-UP (MACHINE) POWERED BY C3.3B Engine

Disassembly and Assembly

C3.3B Tier 4 Final and EU Stage 3B Engines for Caterpillar Built Machines

Media Number -UENR3278-07

Publication Date -01/09/2014

Date Updated -11/07/2016

i05331010

Cylinder Head - Remove and Install

SMCS - 1100-010

Removal Procedure

Start By:

- a. Remove the exhaust manifold.
- b. Remove the inlet manifold.
- c. Remove the rocker arm shaft and pushrods.
- d. Remove the electronic fuel injector.

Note: Refer to Specification UENR3421 "Engine Design" for non-specified engine Torque Values.

1. Drain the coolant from the cooling system into a suitable container for storage or for disposal. Refer to Operation and Maintenance Manual, "Cooling System Coolant (ELC) - Change" for the correct draining and filling procedures.

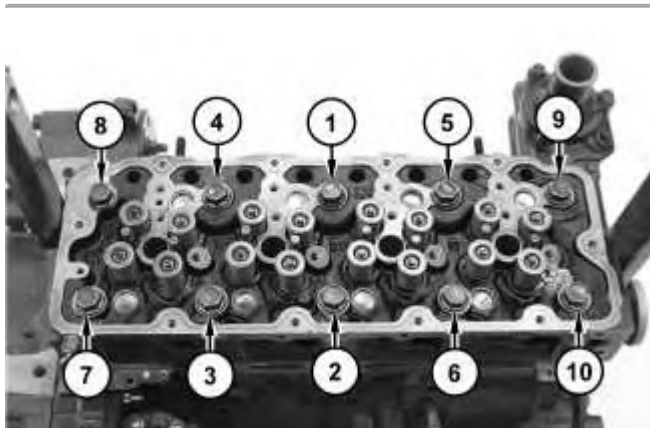

Illustration 1

g03339552

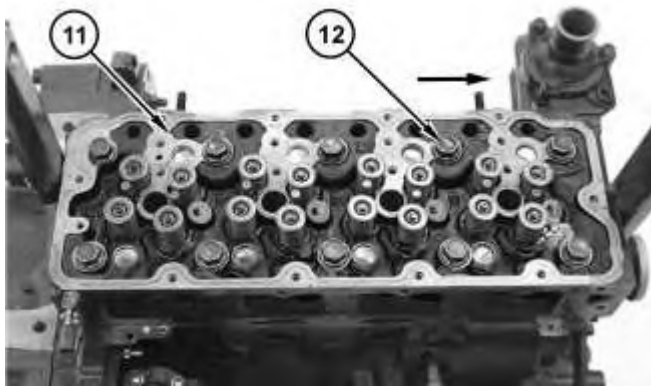

Illustration 2

g03339573

2. Gradually loosen cylinder head bolts (12) in reverse numerical order from (10) through (1) from cylinder head (11). Remove cylinder head bolts (12) from cylinder head (11).
3. Attach a suitable lifting device to cylinder head (11). The weight of cylinder head (11) is approximately 46 kg (100 lb).
4. Use the suitable lifting device to lift cylinder head (11) off the cylinder block.

NOTICE

Place the cylinder head on a surface that will not scratch the face of the cylinder head.

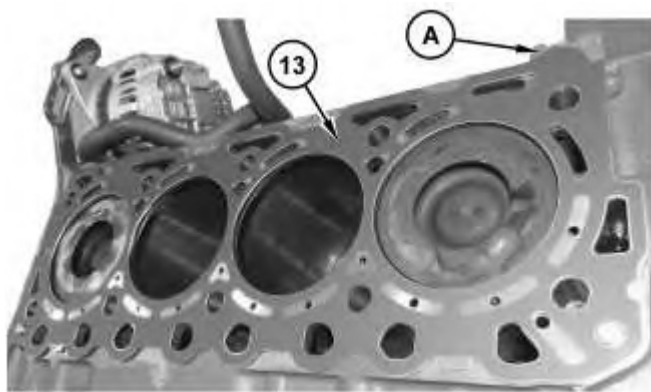

Illustration 3

g03339590

5. Remove cylinder head gasket (13) from the cylinder block.
6. Notice the location of the cylinder head gasket notches in area (A). Refer to illustration 3 and illustrations 4.
7. Note the position of the dowels in the cylinder block.

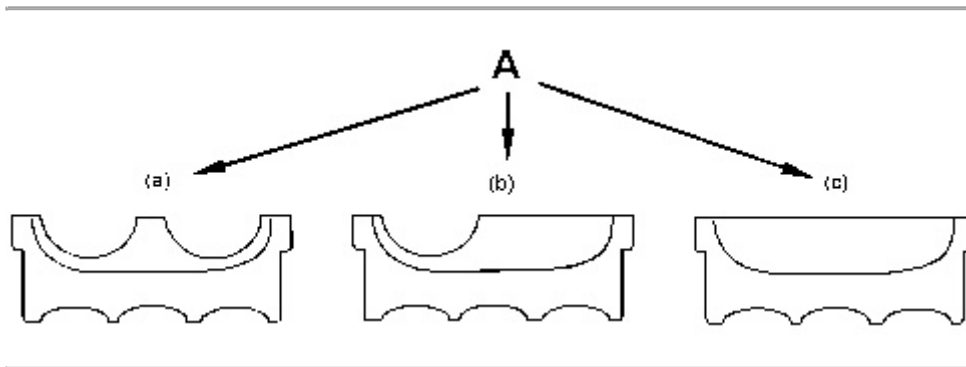

Illustration 4

g02796320

8. Notice the number of notches in area (A).

Table 1

Head Gasket Notch	Head Gasket Thickness		Piston head protrusion or recessing from crankcase cylinder face
	Before Tighten	After Tighten	
(a)-two notches	0.900 mm (0.0354 inch)	0.800 mm (0.0315 inch)	0.0775 to 0.150 mm (0.00306 to 0.00590 in.)
(b)-one notch	1.00 mm (0.039 inch)	0.900 mm (0.0354 inch)	0.150 to 0.250 mm (0.0059 to 0.0098 in.)
(c)-without notch	1.10 mm (0.043 inch)	1.00 mm (0.039 inch)	0.250 to 0.343 mm (0.0098 to 0.0135 in.)

Installation Procedure

Table 2

Required Tools			
Tool	Part Number	Part Description	Qty
A	4C-5592	Thread Lubricant	1

NOTICE

Keep all parts clean from contaminants.

Contaminants may cause rapid wear and shortened component life.

<https://www.ebooklibonline.com>

Hello dear friend!

Thank you very much for reading.

Enter the link into your browser.

The full manual is available for immediate download.

<https://www.ebooklibonline.com>

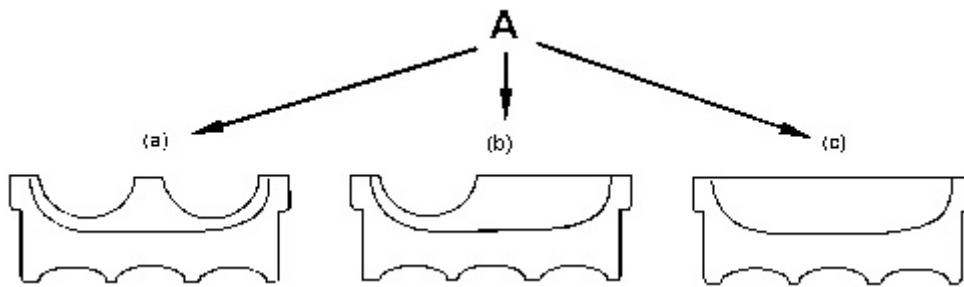

Illustration 5

g02796320

1. Notice the number of notches in area (A). Refer to illustrations 5 and 6.
2. Thoroughly clean the gasket surfaces of the cylinder head and the cylinder block. Do not damage the gasket surfaces of the cylinder head or the cylinder block. Ensure that no debris enters the cylinder bores, the coolant passages, or the lubricant passages.
3. Inspect the dowels for damage. If necessary, replace the dowels in the cylinder block.

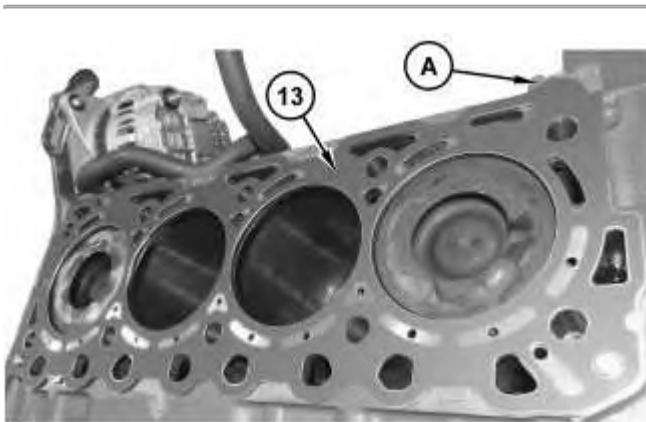
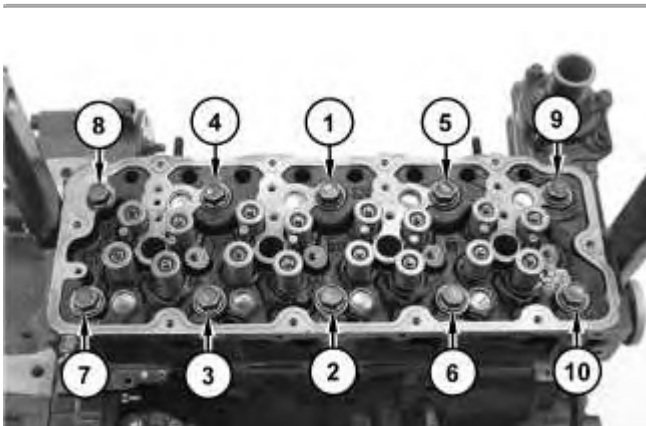

Illustration 6

g03339590

4. Inspect the gasket surface of the cylinder head for distortion. Refer to Specifications, "Cylinder Head" for more information. If the gasket surface of the cylinder head is distorted beyond maximum permitted limits, replace the cylinder head.
5. Notice the location of the cylinder head gasket notches in area (A) and refer to table 2. Align new cylinder head gasket (13) with the dowels.



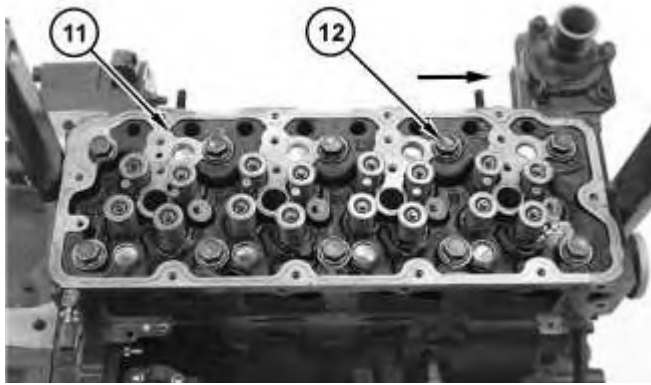

Illustration 8

g03339573

6. Use a suitable lifting device to lift cylinder head (11). The weight of cylinder head (11) is approximately 46 kg (100 lb).
7. Align cylinder head (11) with the cylinder block. Install cylinder head (11) to the cylinder block.

Note: Ensure that the cylinder head is correctly positioned on the dowels.

8. Clean and inspect cylinder head bolts (12).
9. Lubricate the threads and the shoulder of cylinder head bolts (12) with engine oil.
10. Install cylinder head bolts (12) in numerical order from (1) through (10) to cylinder head (11).
11. Tighten the cylinder head bolts according to the following procedure.
 - Tighten bolts (1) through (10) to a torque of 35 N·m (26 lb ft)
 - Tighten bolts (1) through (10) to a torque of 108 N·m (80 lb ft)
 - Tighten bolts (1) through (10) to a torque of 187 to 196 N·m (138 to 144 lb ft)
12. Fill the cooling system with coolant. Refer to Operation and Maintenance Manual, "Cooling System Coolant - Change" for the correct filling procedure.

End By:

- a. Install the electronic fuel injector.
- b. Install the rocker arm shaft and pushrods.
- c. Install the inlet manifold.
- d. Install the exhaust manifold.

Product: WHEEL LOADER

Model: 908M WHEEL LOADER Z88

Configuration: 908M Compact Wheel Loader Z8800001-UP (MACHINE) POWERED BY C3.3B Engine

Disassembly and Assembly

C3.3B Tier 4 Final and EU Stage 3B Engines for Caterpillar Built Machines

Media Number -UENR3278-07

Publication Date -01/09/2014

Date Updated -11/07/2016

i05307111

Camshaft and Valve Lifters - Remove and Install

SMCS - 1209-010; 1210-010

Removal Procedure

Table 1

Required Tools			
Tool	Part Number	Part Description	Qty
A	-	Magnets	8
B	390-1149	Driver	1

Start By:

- a. Remove the rocker shaft and pushrods.
- b. Remove the flywheel housing.
- c. Remove the oil pan. (Only necessary if valve lifters will be removed.)

Note: Refer to Specifications, "Engine Design" for non-specified engine torque values.

NOTICE

Keep all parts clean from contaminants.

Contaminants may cause rapid wear and shortened component life.

1. Find top dead center for number 4 piston. Refer to Testing and Adjusting, "Finding Top Center for No. 4 Piston".

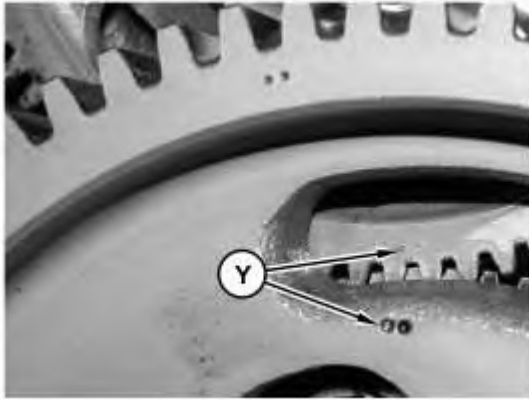

Illustration 1

g02795978

2. Ensure that Timing Marks (Y) on the idler gear and the camshaft gear are aligned. Refer to illustration 1.



Illustration 2

g02798975

3. Use Tooling (A) to hold up the valve lifters (1) in order to remove the camshaft.



Illustration 3

g02796757

NOTICE

Do not damage the lobes or the bearings when the camshaft is removed or installed.

4. Remove bolts (3).
 5. Carefully remove camshaft (2) from the cylinder block.
 6. Remove Tooling (A). Use a suitable container to catch the valve lifters (1) as the valve lifters (1) slide out the bottom of the cylinder block.
-

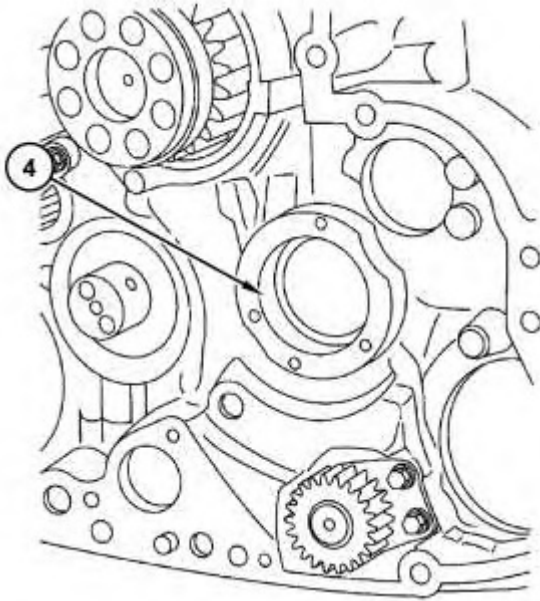

Illustration 4

g02880896

7. Remove camshaft cover (4).

Installation Procedure

1. Install camshaft (2) in the reverse order of removal.
-

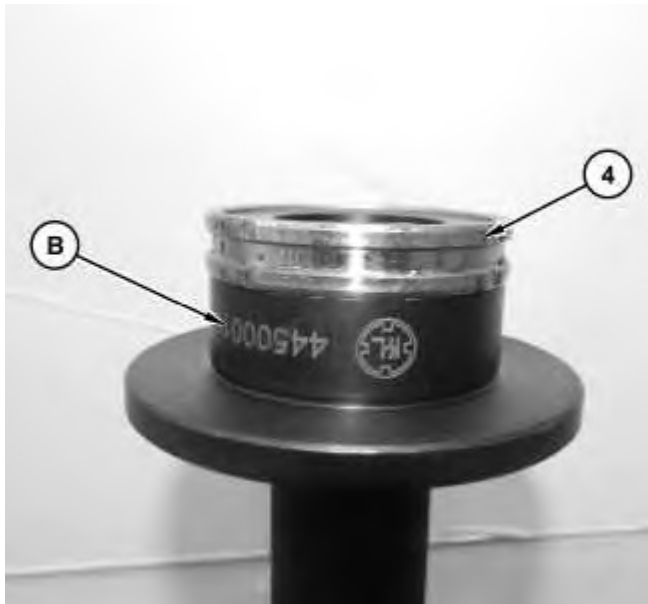

Illustration 5

g02881018

- a. Place camshaft cover (4) on Tooling (B).



Illustration 6

g02881076

- b. Use Tooling (B) to install the camshaft cover (4).
 - c. Tighten bolts (3) to a torque of 24 to 27 N·m (212 to 239 lb in).
-

Product: WHEEL LOADER

Model: 908M WHEEL LOADER Z88

Configuration: 908M Compact Wheel Loader Z8800001-UP (MACHINE) POWERED BY C3.3B Engine

Disassembly and Assembly

C3.3B Tier 4 Final and EU Stage 3B Engines for Caterpillar Built Machines

Media Number -UENR3278-07

Publication Date -01/09/2014

Date Updated -11/07/2016

i05221819

Camshaft Gear - Remove and Install

SMCS - 1210-010-GE

Removal Procedure

Table 1

Required Tools			
Tool	Part Number	Part Description	Qty
A	1P-0510	Driver Group	1
B	8B-7551	Puller Assembly	1
C	8H-0663	Bearing Puller	1

Start By:

- a. Remove the camshaft.

Note: Refer to Specification UENR3421 "Engine Design" for non-specified engine Torque Values.

NOTICE

Care must be taken to ensure that fluids are contained during performance of inspection, maintenance, testing, adjusting and repair of the product. Be prepared to collect the fluid with suitable containers before opening any compartment or disassembling any component containing fluids.

Dispose of all fluids according to local regulations and mandates.

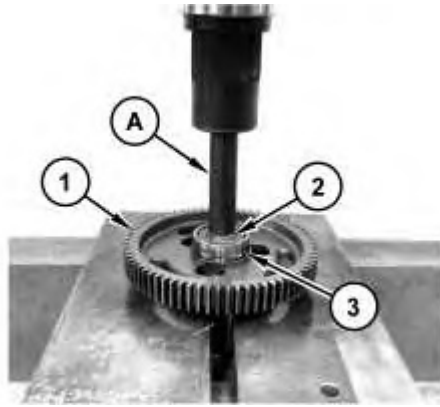

Illustration 1

g02796778

1. Use Tooling (A) in order to remove camshaft gear (1) from camshaft (2).
2. If necessary, apply heat to raise the temperature of the race (3) of the roller bearing to remove.



Illustration 2

g02796779

3. Remove plate (5) from camshaft (2).
4. If necessary, remove key (4) from the nose of camshaft (2).

Installation Procedure

1. Install camshaft gear (1) in the reverse order of removal.
-

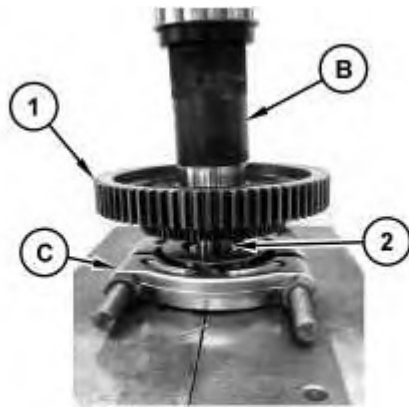

Illustration 3

g02807848

- a. Use Tooling (B) and Tooling (C) in order to install camshaft gear (1) onto camshaft (2).
 - b. Ensure that the camshaft gear and the key are clean and free from wear and damage.
-

Product: WHEEL LOADER

Model: 908M WHEEL LOADER Z88

Configuration: 908M Compact Wheel Loader Z8800001-UP (MACHINE) POWERED BY C3.3B Engine

Disassembly and Assembly

C3.3B Tier 4 Final and EU Stage 3B Engines for Caterpillar Built Machines

Media Number -UENR3278-07

Publication Date -01/09/2014

Date Updated -11/07/2016

i06103443

Engine Oil Pan - Remove and Install

SMCS - 1302-010

Removal Procedure

Table 1

Required Tools			
Tool	Part Number	Part Description	Qty
A	-	LOCTITE® HI-TEMP FLANGE SEALANT	-

Note: Refer to Specification UENR3421 "Engine Design" for non-specified engine Torque Values.

1. Refer to Operation and Maintenance Manual, "Engine Oil and Filter - Change" for the proper draining and filling procedures.



Illustration 1

g02797578

2. Remove bolts (2) and remove oil pan (1) .

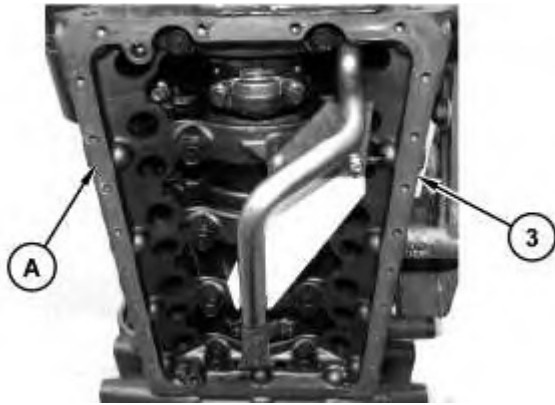

Illustration 2

g02797579

3. Remove Tooling (A) from oil pan (1) and cylinder block (3) surfaces.

Installation Procedure

1. Apply Tooling (A) about 3.0 to 5.0 mm (0.12 to 0.19 inch) thick onto the cylinder block surface. Within 20 minutes after the application of Tooling (A) , reassemble the components.
 - a. Install oil pan (1) in the reverse order of removal.
-

Product: WHEEL LOADER

Model: 908M WHEEL LOADER Z88

Configuration: 908M Compact Wheel Loader Z8800001-UP (MACHINE) POWERED BY C3.3B Engine

Disassembly and Assembly

C3.3B Tier 4 Final and EU Stage 3B Engines for Caterpillar Built Machines

Media Number -UENR3278-07

Publication Date -01/09/2014

Date Updated -11/07/2016

i05328489

Pistons and Connecting Rods - Remove and Install

SMCS - 1225-010

Removal Procedure

Start By:

- a. Remove the cylinder head.
- b. Remove the engine oil pan.

Note: Refer to Specification UENR3421 "Engine Design" for non-specified engine Torque Values.

1. Rotate the crankshaft until the crank pin is at the bottom center position.

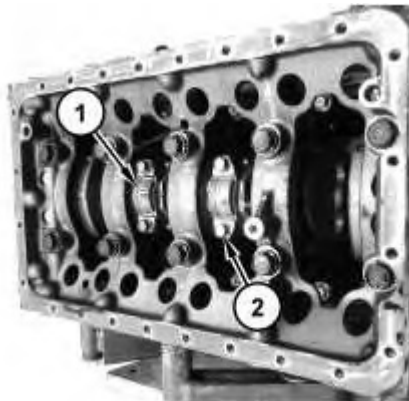

Illustration 1

g02797660

2. Remove bolts (2) and remove connecting rod cap (1).
-



Illustration 2

g02797658

3. Carefully push piston (3) and the connecting rod from cylinder block (4) bore.
4. The connecting rod and the connecting rod cap should have an etched Number (X) on the side. The number on the connecting rod and the connecting rod cap must match. Ensure that the connecting rod and the connecting rod cap are marked for the correct location. If necessary, make a temporary mark on the connecting rod and the connecting rod cap in order to identify the cylinder number.

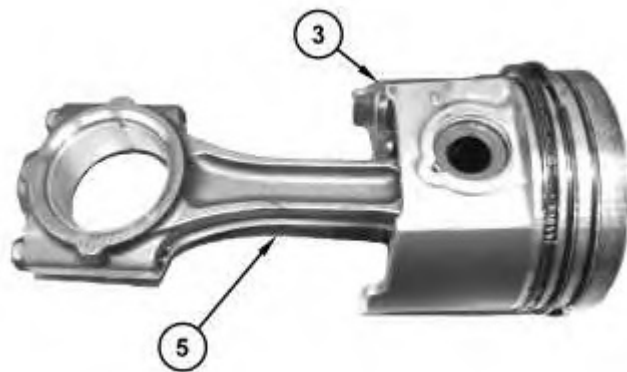

Illustration 3

g02797689

5. Remove piston (3) and connecting rod (5).

Installation Procedure

Table 1

Required Tools			
Tool	Part Number	Part Description	Qty
A	1U-6684	Piston Ring Compressor	1

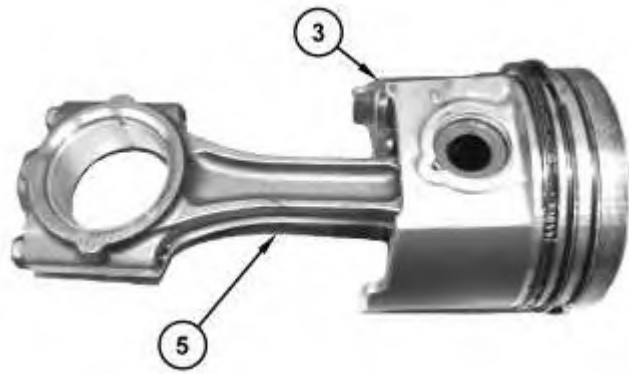

Illustration 4

g02797689

1. Inspect piston (3) and connecting rod assembly (5).
2. Apply clean engine oil to the cylinder bore, to the piston rings, to the outer surface of the piston and to the bearing shells.

Note: Install the bearing shells for the connecting rods dry when clearance checks are performed. Refer to Disassembly and Assembly, "Bearing Clearance - Check" for the correct procedure. Apply clean engine oil to the bearing shells for the connecting rods during final assembly.

Note: Ensure that the piston and the connecting rod assembly are installed in the correct cylinder.

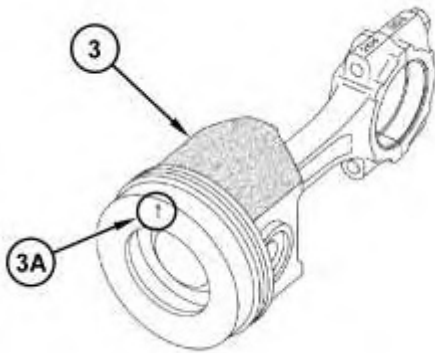

Illustration 5

g03375806

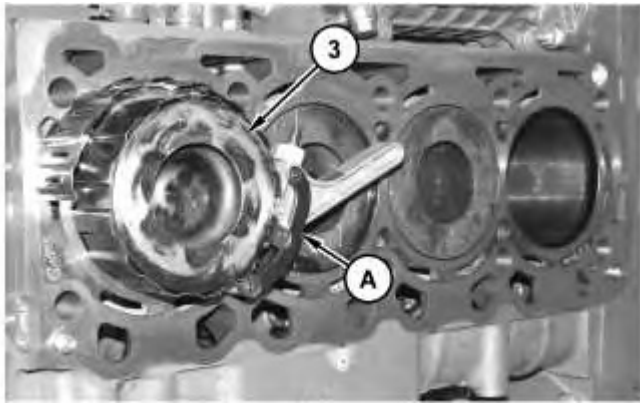

Illustration 6

g02797721

Note: During installation position Arrow (3A) on the face of piston (3) towards the fuel pump side of the engine.

3. Install Tooling (A) onto piston (3).

Note: Ensure that Tooling (A) is installed correctly and that piston (3) can easily slide from the tool.



Illustration 7

g02797658

4. Carefully push piston (3) and the connecting rod assembly into cylinder block (4) bore and onto the crankshaft pin.

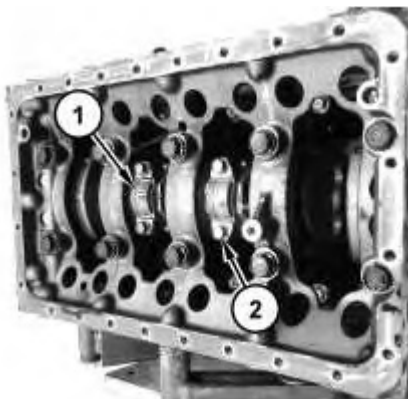

5. Install connecting rod cap (1) onto the connecting rod .

Note: Ensure that etched Number (X) on connecting rod cap (1) matches etched Number (X) on the connecting rod. Ensure the correct orientation of the connecting rod cap. The locating tab for the upper bearing shell and the lower bearing shell should be on the same side.

Note: Do not reuse the old connecting rod bolts in order to secure the connecting rod cap.

6. Apply clean engine oil to bolt threads and install new bolts (2) to the connecting rod. Tighten bolts (2) to a torque of 69 to 73 N·m (51 to 54 lb ft).
7. Ensure that the installed connecting rod assembly has side play. Rotate the crankshaft in order to ensure that there is no binding.
8. Repeat Step 1 through Step 7 in order to install the remaining pistons and connecting rods.

End By:

- a. Install the engine oil pan.
 - b. Install the cylinder head.
-



Suggest:

For more complete manuals. Please go to the home page.

<https://www.ebooklibonline.com>

If the above button click is invalid. Please download this document first, and then click the above link to download the complete manual.

Thank you so much for reading

Product: WHEEL LOADER

Model: 908M WHEEL LOADER Z88

Configuration: 908M Compact Wheel Loader Z8800001-UP (MACHINE) POWERED BY C3.3B Engine

Disassembly and Assembly

C3.3B Tier 4 Final and EU Stage 3B Engines for Caterpillar Built Machines

Media Number -UENR3278-07

Publication Date -01/09/2014

Date Updated -11/07/2016

i05845139

Pistons and Connecting Rods - Disassemble

SMCS - 1225-015

Disassembly Procedure

Table 1

Required Tools			
Tool	Part Number	Part Description	Qty
A	1U-6683	Ring Expander	1
B	393-2568	Bearing Removal Tool	1
	443-9447	Support Plate	1

Start By:

- a. Remove the pistons and connecting rods.

Note: Make a temporary mark on the components of the piston and connecting rod assembly. Marking the components will ensure that the components of each piston and connecting rod assembly can be reinstalled in the original cylinder. Mark the underside of the piston on the front pin boss. Do not interchange components.



Illustration 1

g02723365

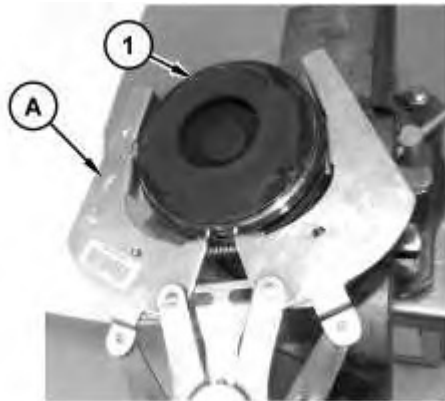

Illustration 2

g02723368

1. Position the piston and connecting rod in a soft jaw vise. Use Tooling (A) to remove three rings (2) from piston (1).
-



Illustration 3

g02723373

<https://www.ebooklibonline.com>

Hello dear friend!

Thank you very much for reading.

Enter the link into your browser.

The full manual is available for immediate download.

<https://www.ebooklibonline.com>