

Product: COMPACT WHEEL LOADER

Model: 908 COMPACT WHEEL LOADER 8BS

Configuration: 908 Compact Wheel Loader 8BS00001-01715 (MACHINE) POWERED BY 3054 Engine

Disassembly and Assembly 3054 Engine for Caterpillar Built Machines

Media Number -SEN6241-13

Publication Date -01/08/2008

Date Updated -04/08/2008

i02253357

Gear Group (Front) - Remove

SMCS - 1206-011

Removal Procedure

Table 1

Required Tools			
Tool	Part Number	Part Description	Qty
A	8S-2264	Puller Group	1
B	173-9774	Wrench Bit	1

Start By:

- A. Remove the front cover. Refer to Disassembly and Assembly, "Front Cover - Remove".

NOTICE

Keep all parts clean from contaminants.

Contaminants may cause rapid wear and shortened component life.

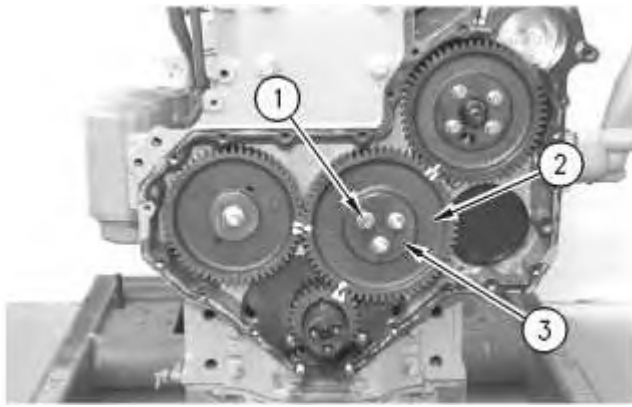

Illustration 1

g00556563

Note: It may be necessary to pin the fuel pump in order to maintain the correct timing. Refer to Disassembly and Assembly, "Fuel Injection Pump - Remove" for the correct procedure.

1. Align the timing marks on the crankshaft gear, the camshaft gear, and the idler gear, as shown.
2. Remove bolts (1) from idler gear (2) .
3. Remove idler gear (2) and retainer plate (3) .



Illustration 2

g00556757

4. Remove bushing (4) from idler gear (2) , if necessary.
5. Remove the bushing with a suitable puller. If the bushing cannot be removed with a puller, grind the face off of one bushing. The remainder of the bushing can then be removed with a press.

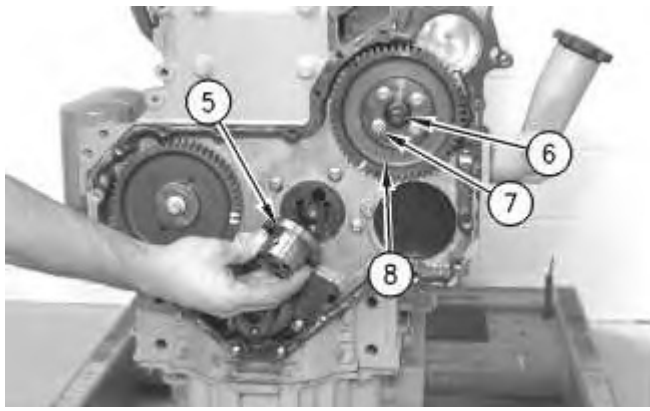

Illustration 3

g00556758

6. Remove idler gear hub (5) from the cylinder block.
7. Remove nut (6) and the spring washer from fuel injection pump gear (8) .
8. Remove bolts (7) from fuel injection pump gear (8) .

Note: Some fuel injection pump gears may have a tamper proof torx screw in place of one of the four bolts. Use Tooling (B) to remove the tamper proof torx screw, if necessary.

9. Use Tooling (A) to remove fuel injection pump gear (8) .
-

<https://www.ebooklibonline.com>

Hello dear friend!

Thank you very much for reading.

Enter the link into your browser.

The full manual is available for immediate download.

<https://www.ebooklibonline.com>

Product: COMPACT WHEEL LOADER

Model: 908 COMPACT WHEEL LOADER 8BS

Configuration: 908 Compact Wheel Loader 8BS00001-01715 (MACHINE) POWERED BY 3054 Engine

Disassembly and Assembly 3054 Engine for Caterpillar Built Machines

Media Number -SEN6241-13

Publication Date -01/08/2008

Date Updated -04/08/2008

i01744102

Gear Group (Front) - Install

SMCS - 1206-012

Installation Procedure

NOTICE

Keep all parts clean from contaminants.

Contaminants may cause rapid wear and shortened component life.

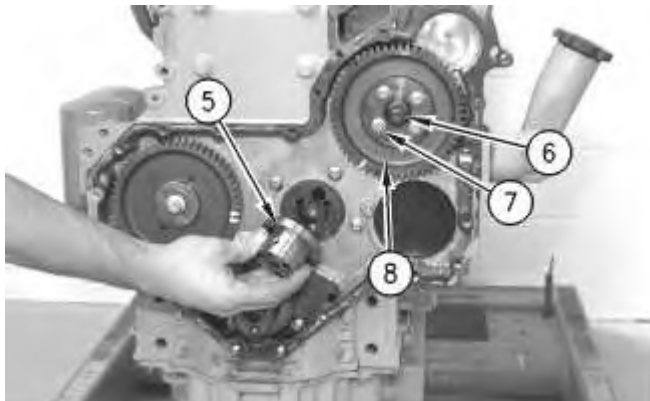

Illustration 1

g00556758

1. Install fuel injection pump gear (8) on the engine.
2. Install bolts (7) on fuel injection pump gear (8).

3. Install nut (6) and the spring washer on fuel injection pump gear (8). Tighten the nut to a torque of 80 N·m (59 lb ft).
4. Install idler gear hub (5) on the engine.



Illustration 2

g00556757

5. Use a suitable press to install new bushings (4) into idler gear (2).
6. Machine the bores for clearance on idler gear hub (5). The bore should have a clearance of 0.04 to 0.010 mm (0.0016 to 0.0039 inch) on idler gear hub (5). The bore can have a diameter of 57.14 to 57.18 mm (2.250 to 2.251 inch).
7. Machine the front faces of the bushings for the end play of idler gear (2). The gear and the bushings can have a thickness of 30.14 to 30.16 mm (1.186 to 1.187 inch).

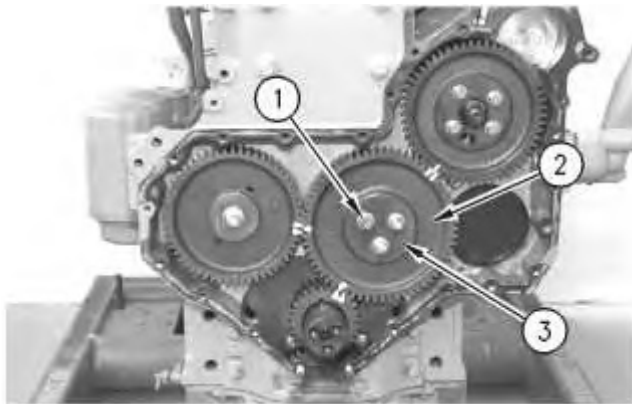

Illustration 3

g00556563

8. Install idler gear (2) and retainer plate (3) on the engine.

Note: Ensure that the timing marks on the camshaft gear, the crankshaft gear, and the idler gear are aligned.

9. Install bolts (1) on idler gear (2). Tighten the bolts to a torque of 44 N·m (32 lb ft).
10. Check the end play of idler gear (2). Idler gear (2) should have end play of 0.10 to 0.20 mm (0.004 to 0.008 inch).

11. Check the backlash between the camshaft gear and idler gear (2). The gears must have a minimum backlash of 0.08 mm (0.003 inch).

End By:

- a. Install the front cover. Refer to Disassembly and Assembly, "Front Cover - Install".
-

Product: COMPACT WHEEL LOADER

Model: 908 COMPACT WHEEL LOADER 8BS

Configuration: 908 Compact Wheel Loader 8BS00001-01715 (MACHINE) POWERED BY 3054 Engine

Disassembly and Assembly 3054 Engine for Caterpillar Built Machines

Media Number -SEN6241-13

Publication Date -01/08/2008

Date Updated -04/08/2008

i01744128

Housing (Front) - Remove

SMCS - 1151-011

Removal Procedure

Start By:

- a. Remove the engine oil pan. Refer to Disassembly and Assembly, "Engine Oil Pan - Remove and Install".
- b. Remove the front gear group. Refer to Disassembly and Assembly, "Gear Group (Front) - Remove".
- c. Remove the camshaft gear. Refer to Disassembly and Assembly, "Camshaft Gear - Remove and Install".

NOTICE

Keep all parts clean from contaminants.

Contaminants may cause rapid wear and shortened component life.

NOTICE

Care must be taken to ensure that fluids are contained during performance of inspection, maintenance, testing, adjusting and repair of the product. Be prepared to collect the fluid with suitable containers before opening any compartment or disassembling any component containing fluids.

Refer to Special Publication, NENG2500, "Caterpillar Dealer Service Tool Catalog" for tools and supplies suitable to collect and contain fluids on Caterpillar products.

Dispose of all fluids according to local regulations and mandates.

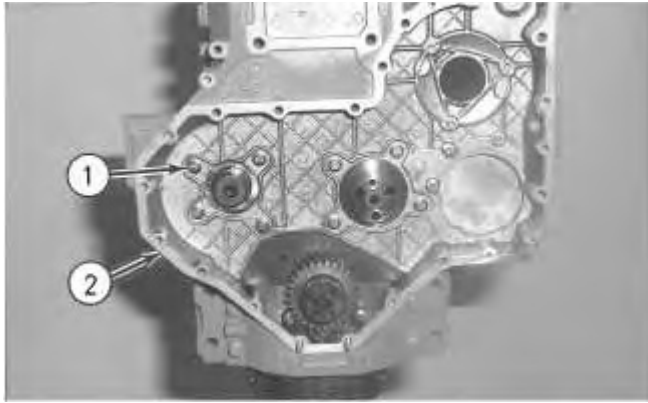

Illustration 1

g00549819

1. Remove all bolts (1) that fasten the front housing (2) to the cylinder block.

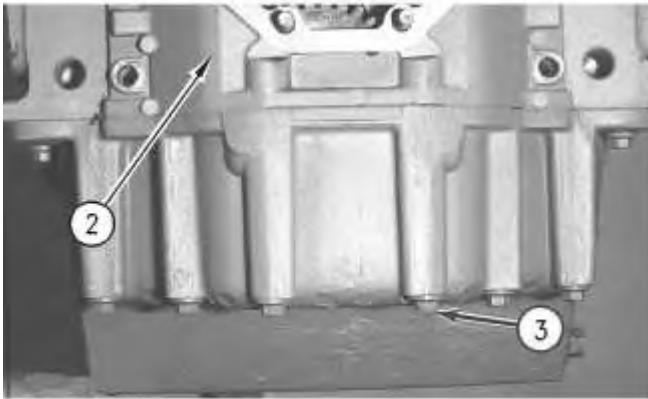

Illustration 2

g00549821

2. Remove bolts (3) that hold the oil pan to the bottom of front housing (2).
 3. Remove front housing (2) and the gasket.
-

Product: COMPACT WHEEL LOADER

Model: 908 COMPACT WHEEL LOADER 8BS

Configuration: 908 Compact Wheel Loader 8BS00001-01715 (MACHINE) POWERED BY 3054 Engine

Disassembly and Assembly 3054 Engine for Caterpillar Built Machines

Media Number -SEN6241-13

Publication Date -01/08/2008

Date Updated -04/08/2008

i06815567

Housing (Front) - Install

SMCS - 1151-012

Installation Procedure

Table 1

Required Tools			
Tool	Part Number	Part Description	Qty
A	-	Loctite Gasket Sealant No. 2	-

NOTICE

Keep all parts clean from contaminants.

Contaminants may cause rapid wear and shortened component life.

1. Replace the gasket.
 2. Apply Tooling (A) to the bottom portion of the gasket.
-

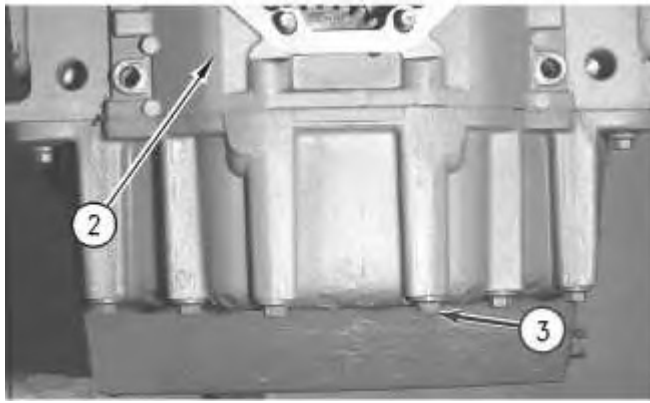

Illustration 1

g00549821

3. If necessary, install the studs (not shown) to the back of the front housing (2) that holds the fuel injection pump in position. Tighten the studs to a torque of 11 N·m (97 lb in). Install the gasket and front housing (2). Cut the gasket to the correct length, if necessary.
4. Install bolts (3) that hold the engine oil pan to the bottom of the front housing. Tighten the bolts to a torque of 22 N·m (16 lb ft).

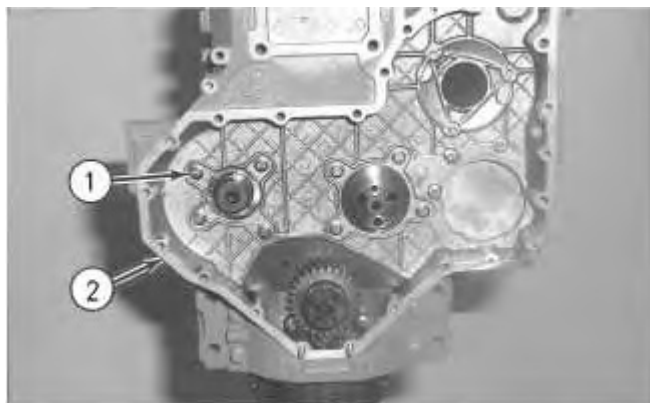

Illustration 2

g00549819

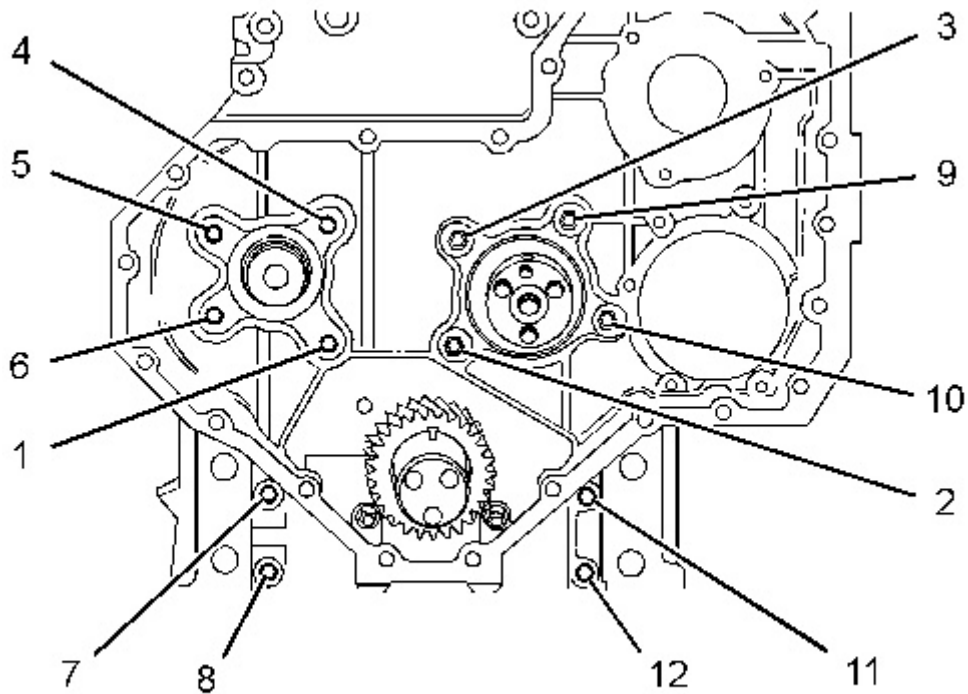

Illustration 3

g03549798

5. Install all bolts (1) that fasten the front housing (2) to the cylinder block and to the oil pan. Tighten bolts (1) to a torque of 22 N·m (16 lb ft) using the sequence in Illustration 3.

Note: Ensure that the bottom of the front housing is aligned with the bottom of the cylinder block.

End By:

- a. Install the camshaft gear.
 - b. Install the front gear group.
 - c. Install the engine oil pan.
-

Product: COMPACT WHEEL LOADER

Model: 908 COMPACT WHEEL LOADER 8BS

Configuration: 908 Compact Wheel Loader 8BS00001-01715 (MACHINE) POWERED BY 3054 Engine

Disassembly and Assembly 3054 Engine for Caterpillar Built Machines

Media Number -SEN6241-13

Publication Date -01/08/2008

Date Updated -04/08/2008

i01054405

Valve Mechanism Cover - Remove and Install

SMCS - 1107-010

Removal Procedure

NOTICE

Keep all parts clean from contaminants.

Contaminants may cause rapid wear and shortened component life.

NOTICE

Care must be taken to ensure that fluids are contained during performance of inspection, maintenance, testing, adjusting and repair of the product. Be prepared to collect the fluid with suitable containers before opening any compartment or disassembling any component containing fluids.

Refer to Special Publication, NENG2500, "Caterpillar Tools and Shop Products Guide" for tools and supplies suitable to collect and contain fluids on Caterpillar products.

Dispose of all fluids according to local regulations and mandates.

Note: The engines are equipped with either an aluminum valve cover or with a composite valve cover. The aluminum valve cover has a seal that fits between the valve cover and the inlet

manifold. The composite valve cover has a seal that is permanently fixed to the side of the valve cover.

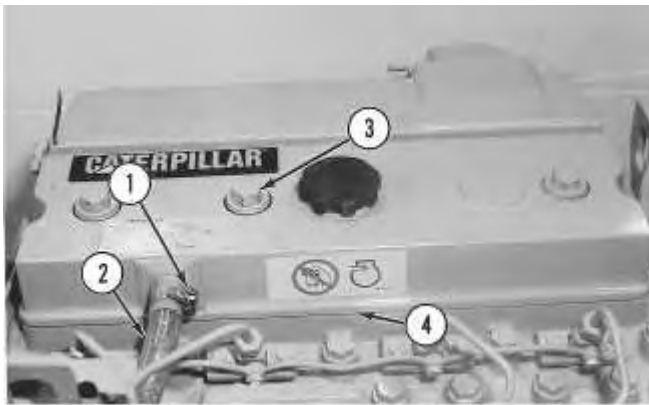

Illustration 1

g00547002

Typical example

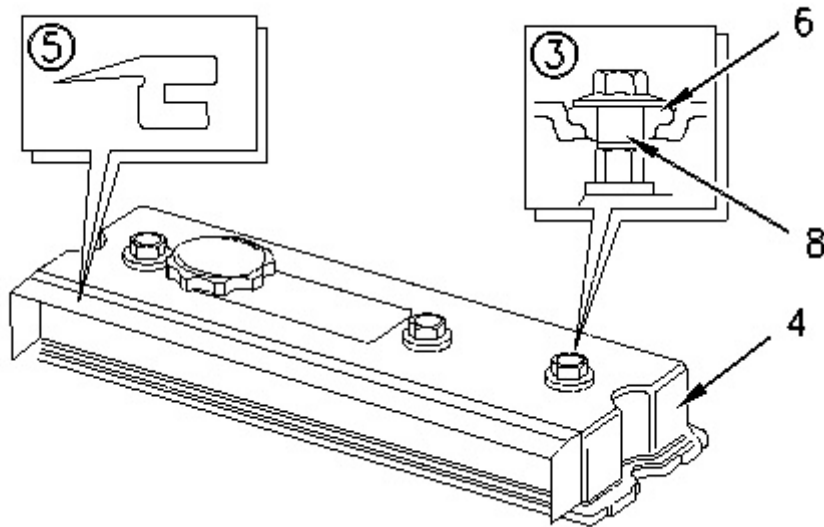

Illustration 2

g00547003

Aluminum valve cover

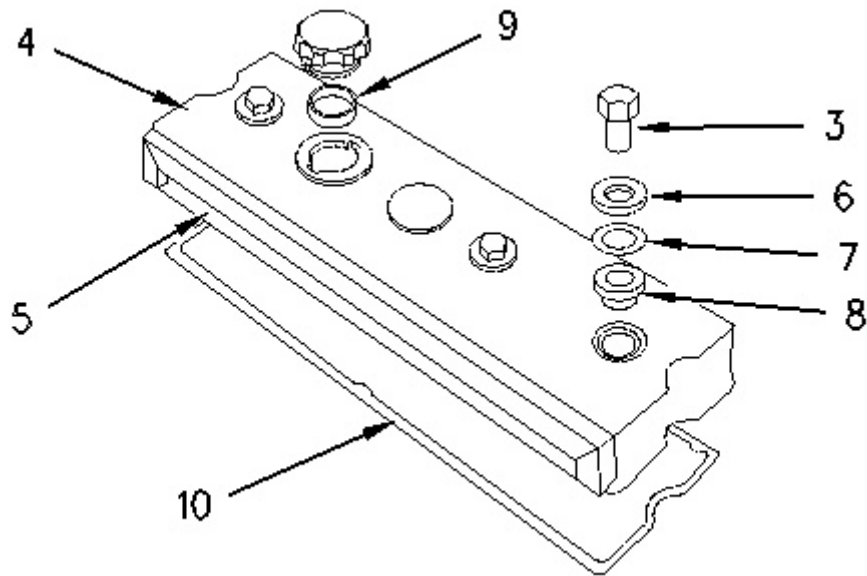

Illustration 3

g00547004

Composite valve cover

1. Loosen hose clamp (1) .
2. Disconnect breather hose (2) .
3. Remove three nuts (3), steel washers (6), and sealing washers (8) .

Note: When you remove nuts (3), ensure that the nuts on the rocker arm bracket are not loosened.

Note: Current production engines have an additional shim washer (7) .

4. Remove valve cover (4), gasket (10), and seal (5) .
5. Remove seal (9) for the oil filler cap.

Installation Procedure

Note: The engines are equipped with either an aluminum valve cover or with a composite valve cover. The aluminum valve cover has a seal that fits between the valve cover and the inlet manifold. The composite valve cover has a seal that is permanently fixed to the side of the valve cover.

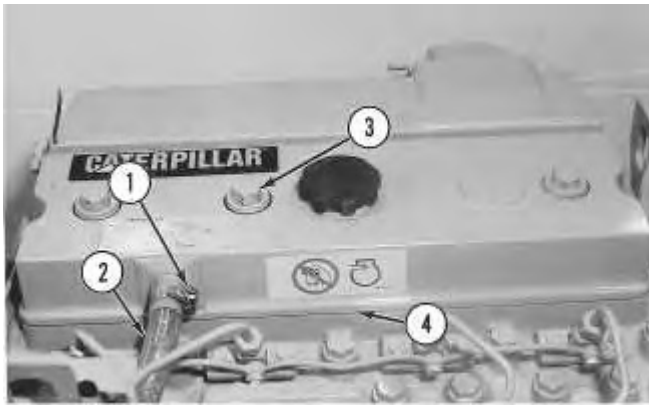

Illustration 4

g00547002

Typical example

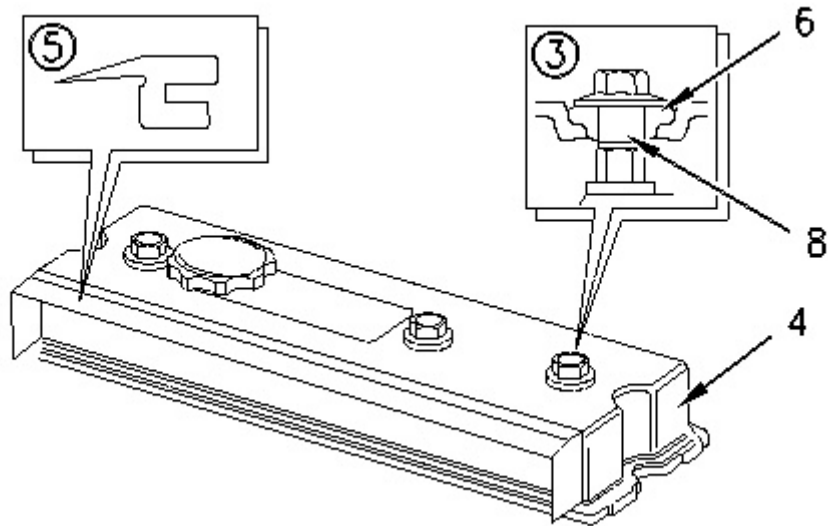

Illustration 5

g00547003

Aluminum valve cover

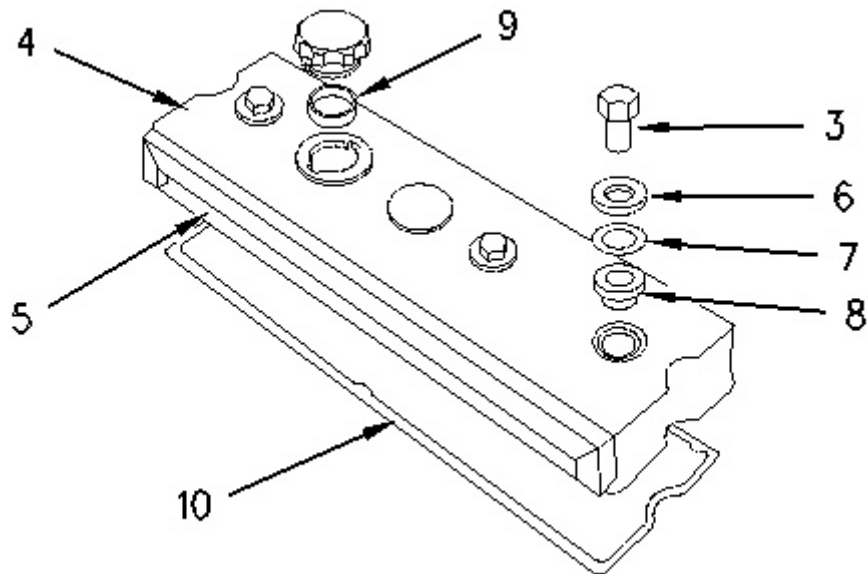

Illustration 6

g00547004

Composite valve cover

1. Inspect the condition of the gaskets and the seals. Replace the gaskets and the seals, if necessary.
2. Install seal (9) for the oil filler cap, if necessary.
3. Apply **8T-9022** Silicone Gasket to gasket (10) .

Note: Ensure that the flat face of the gasket is toward the valve cover.

4. Install gasket (10), seal (5), and valve cover (4) .
5. Lubricate three nuts (3) with clean engine oil.
6. Install three nuts (3), steel washers (6), and sealing washers (8) .

Note: When you install three nuts (3) without shim washers (7), tighten the nuts to a torque of 20 N·m (15 lb ft). Do not overtighten the nuts.

Note: When you install three nuts (3) with shim washers (7), tighten the nuts to a torque of 30 N·m (22 lb ft). Do not overtighten the nuts.

7. Connect breather hose (2) .
 8. Tighten hose clamp (1) .
-

Product: COMPACT WHEEL LOADER

Model: 908 COMPACT WHEEL LOADER 8BS

Configuration: 908 Compact Wheel Loader 8BS00001-01715 (MACHINE) POWERED BY 3054 Engine

Disassembly and Assembly 3054 Engine for Caterpillar Built Machines

Media Number -SEN6241-13

Publication Date -01/08/2008

Date Updated -04/08/2008

i01761173

Rocker Shaft and Pushrod - Remove

SMCS - 1102-011; 1208-011

Removal Procedure

Start By:

- a. Remove the valve mechanism cover. Refer to Disassembly and Assembly, "Valve Mechanism Cover - Remove and Install".

NOTICE

Keep all parts clean from contaminants.

Contaminants may cause rapid wear and shortened component life.



Illustration 1

g00635152

Typical example

Note: It is not necessary to remove the oil supply tube in order to remove the rocker shaft assembly and the pushrods.

1. Remove nuts (1) and bolt (2) from the rocker shaft assembly. Begin with the end brackets and move toward the center.
2. Remove rocker shaft assembly (3).
3. Remove the oil seal from the oil supply passage in the cylinder head.

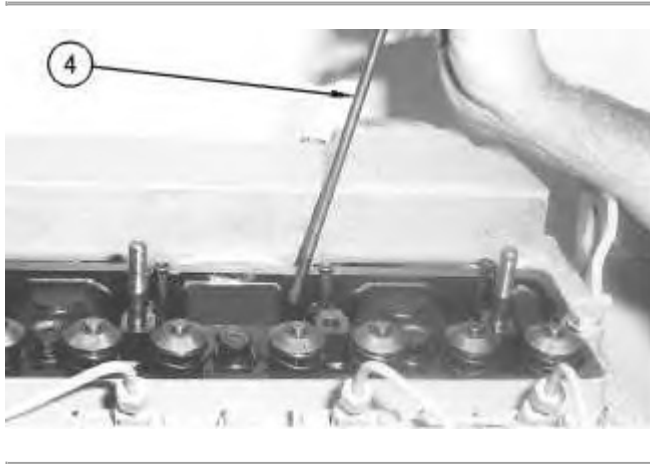

Illustration 2

g00635153

Typical example

4. Remove pushrods (4). Place an identification mark on the pushrods for installation.
-



Suggest:

For more complete manuals. Please go to the home page.

<https://www.ebooklibonline.com>

If the above button click is invalid. Please download this document first, and then click the above link to download the complete manual.

Thank you so much for reading

Product: COMPACT WHEEL LOADER

Model: 908 COMPACT WHEEL LOADER 8BS

Configuration: 908 Compact Wheel Loader 8BS00001-01715 (MACHINE) POWERED BY 3054 Engine

Disassembly and Assembly 3054 Engine for Caterpillar Built Machines

Media Number -SEN6241-13

Publication Date -01/08/2008

Date Updated -04/08/2008

i01667090

Rocker Shaft - Disassemble

SMCS - 1102-015

Disassembly Procedure

Table 1

Required Tools			
Tool	Part Number	Part Description	Qty
A	1P-0510	Driver Group	1

Start By:

- A. Remove the rocker shaft assembly. Refer to Disassembly and Assembly, "Rocker Shaft and Pushrod - Remove".



Illustration 1

g00550061

1. Use a screwdriver or a similar tool to remove retaining ring (1) from both ends of the rocker shaft assembly.

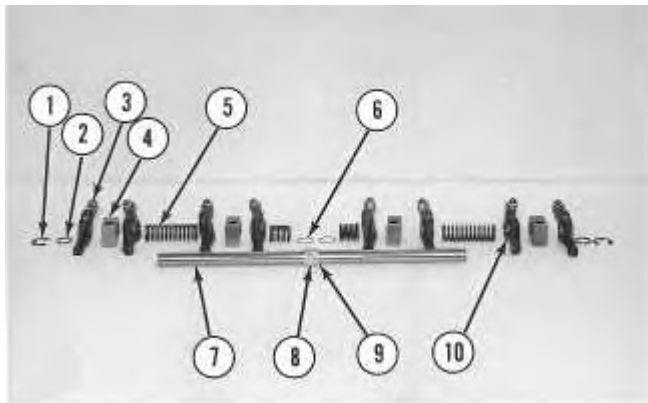

Illustration 2

g00550062

- (1) Retaining ring
 - (2) Washer on the end of the rocker shaft
 - (3) Rocker arm assembly
 - (4) Rocker shaft bracket
 - (5) Spring on the rocker shaft
 - (6) Washer
 - (7) Rocker shaft
 - (8) Bolt
 - (9) Oil supply connection
 - (10) Rocker arm bushing
2. Remove the rocker arms and the rocker shaft brackets from the rocker shaft assembly.
Note: Place an identification mark on each of the components for the proper order for installation.
 3. Check the clearance between rocker arm assembly (3) and rocker shaft (7). Replace rocker arm bushing (10) if the clearance is larger than 0.13 mm (0.005 inch). Use Tool (A) and a suitable press in order to remove rocker arm bushing (10) from rocker arm assembly (3), if necessary.
 4. Remove rocker shaft bracket (4) from rocker shaft (7) .
 5. Remove springs (5), washer (6), bolt (8) and oil supply connection (9) from rocker shaft (7) .

<https://www.ebooklibonline.com>

Hello dear friend!

Thank you very much for reading.

Enter the link into your browser.

The full manual is available for immediate download.

<https://www.ebooklibonline.com>