

Product: COMPACT WHEEL LOADER

Model: 907H2 COMPACT WHEEL LOADER JRS

Configuration: 907H2 Wheel Loader JRS00001-UP (MACHINE) POWERED BY C3.3B Engine

Disassembly and Assembly C2.6 and C3.3B Engines for Caterpillar Built Machines

Media Number -UENR0137-11

Publication Date -01/08/2015

Date Updated -12/07/2018

i05242932

Camshaft Gear - Remove and Install

SMCS - 1210-010-GE

Removal Procedure

Table 1

Required Tools			
Tool	Part Number	Part Description	Qty
A	1P-0510	Driver Group	1
B	8B-7551	Puller Assembly	1
C	8H-0663	Bearing Puller	1

Start By:

- a. Remove the camshaft.

Note: Refer to Specification UENR0995 "Engine Design" for non-specified engine Torque Values.

NOTICE

Care must be taken to ensure that fluids are contained during performance of inspection, maintenance, testing, adjusting and repair of the product. Be prepared to collect the fluid with suitable containers before opening any compartment or disassembling any component containing fluids.

Dispose of all fluids according to local regulations and mandates.

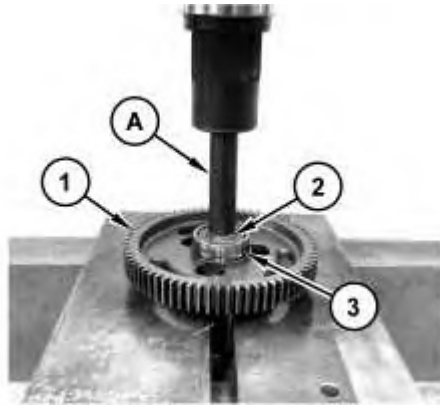

Illustration 1

g02796778

1. Use Tooling (A) in order to remove camshaft gear (1) from camshaft (2).
2. If necessary, apply heat to raise the temperature of the race (3) of the roller bearing to remove.

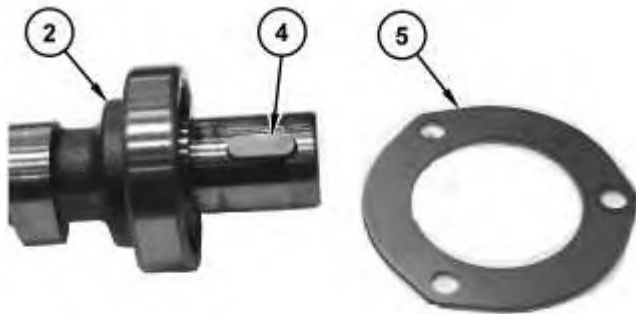

Illustration 2

g02796779

3. Remove plate (5) from camshaft (2).
4. If necessary, remove the key (4) from the nose of camshaft (2).

Installation Procedure

1. Install camshaft gear (1) in the reverse order of removal.
-

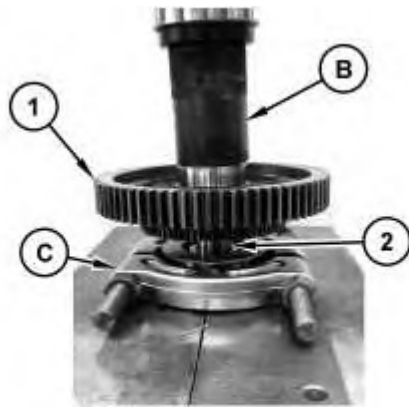

Illustration 3

g02807848

- a. Use Tooling (B) and Tooling (C) in order to install camshaft gear (1) onto camshaft (2).
 - b. Ensure that the camshaft gear and the key are clean and free from wear and damage.
-

<https://www.ebooklibonline.com>

Hello dear friend!

Thank you very much for reading.

Enter the link into your browser.

The full manual is available for immediate download.

<https://www.ebooklibonline.com>

Product: COMPACT WHEEL LOADER

Model: 907H2 COMPACT WHEEL LOADER JRS

Configuration: 907H2 Wheel Loader JRS00001-UP (MACHINE) POWERED BY C3.3B Engine

Disassembly and Assembly C2.6 and C3.3B Engines for Caterpillar Built Machines

Media Number -UENR0137-11

Publication Date -01/08/2015

Date Updated -12/07/2018

i05242933

Engine Oil Pan - Remove and Install

SMCS - 1302-010

Removal Procedure

Table 1

Required Tools			
Tool	Part Number	Part Description	Qty
A	-	LOCTITE 38364 Flange Sealant	1

Note: Refer to Specification UENR0995 "Engine Design" for non-specified engine Torque Values.

1. Refer to Operation and Maintenance Manual, "Engine Oil and Filter - Change" for the proper draining and filling procedures.



Illustration 1

g02797578

2. Remove bolts (2) and remove oil pan (1).

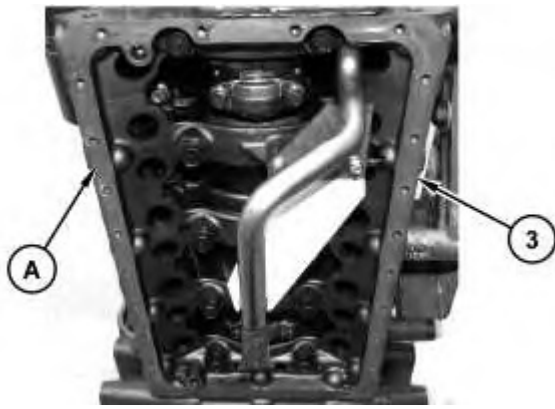

Illustration 2

g02797579

3. Remove Tooling (A) from oil pan (1) and cylinder block (3) surfaces.

Installation Procedure

1. Install oil pan (1) in the reverse order of removal.
 - a. Apply Tooling (A) to cylinder block (3) surface.
-

Product: COMPACT WHEEL LOADER

Model: 907H2 COMPACT WHEEL LOADER JRS

Configuration: 907H2 Wheel Loader JRS00001-UP (MACHINE) POWERED BY C3.3B Engine

Disassembly and Assembly C2.6 and C3.3B Engines for Caterpillar Built Machines

Media Number -UENR0137-11

Publication Date -01/08/2015

Date Updated -12/07/2018

i05242938

Pistons and Connecting Rods - Remove and Install

SMCS - 1225-010

Removal Procedure

Start By:

- a. Remove cylinder head.
- b. Remove engine oil pan.

Note: Refer to Specification UENR0995 "Engine Design" for non-specified engine Torque Values.

1. Rotate the crankshaft until the crank pin is at the bottom center position.



Illustration 1

g02797660

2. Remove bolts (2) and remove connecting rod cap (1).
-

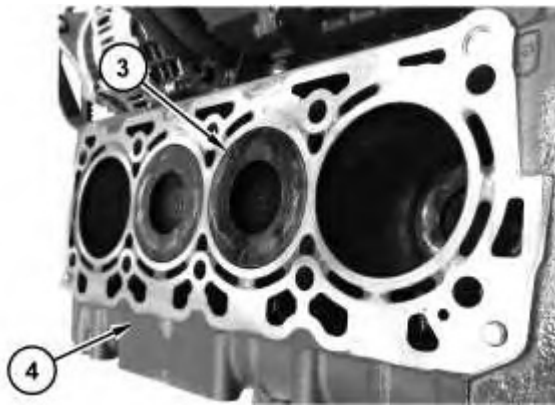

Illustration 2

g02797658

3. Carefully push piston (3) and the connecting rod from cylinder block (4) bore.
4. The connecting rod and the connecting rod cap should have an etched Number (X) on the side. The number on the connecting rod and the connecting rod cap must match. Ensure that the connecting rod and the connecting rod cap are marked for the correct location. If necessary, make a temporary mark on the connecting rod and the connecting rod cap in order to identify the cylinder number.

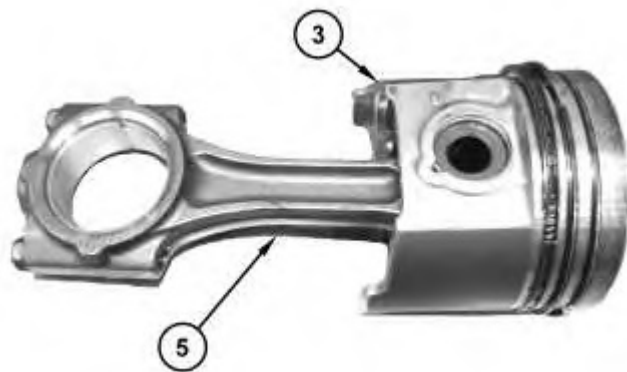

Illustration 3

g02797689

5. Remove piston (3) and connecting rod (5).

Installation Procedure

Table 1

Required Tools			
Tool	Part Number	Part Description	Qty
A	1U-6684	Piston Ring Compressor	1

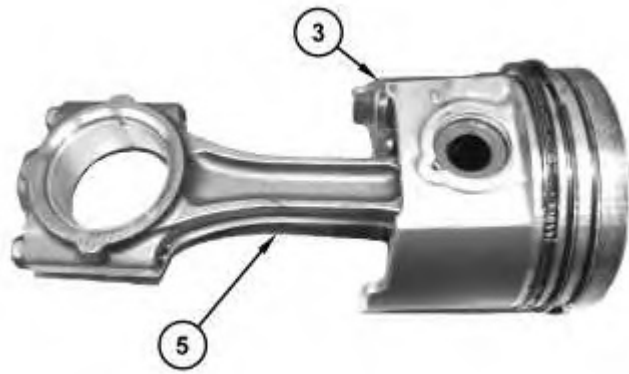

Illustration 4

g02797689

1. Inspect piston (3) and connecting rod assembly (5).
2. Apply clean engine oil to the cylinder bore, to the piston rings, to the outer surface of the piston and to the bearing shells.

Note: Install the bearing shells for the connecting rods dry when clearance checks are performed. Refer to Disassembly and Assembly, "Bearing Clearance - Check" for the correct procedure. Apply clean engine oil to the bearing shells for the connecting rods during final assembly.

Note: Ensure that the piston and the connecting rod assembly are installed in the correct cylinder.

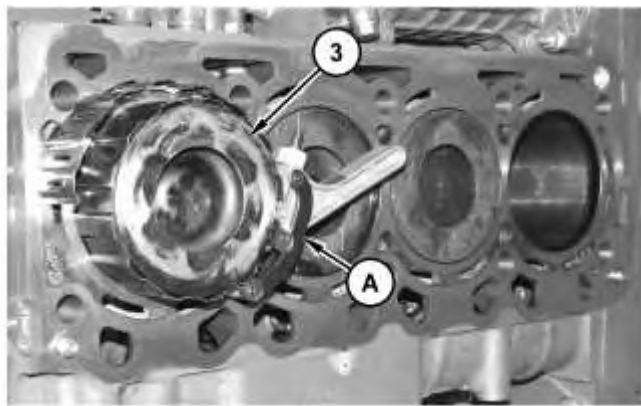

Illustration 5

g02797721

3. Install Tooling (A) onto piston (3).

Note: Ensure that Tooling (A) is installed correctly and that piston (3) can easily slide from the tool.

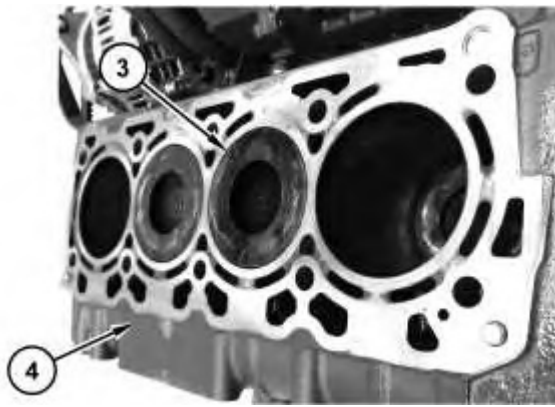

Illustration 6

g02797658

- Carefully push piston (3) and the connecting rod assembly into cylinder block (4) bore and onto the crankshaft pin.

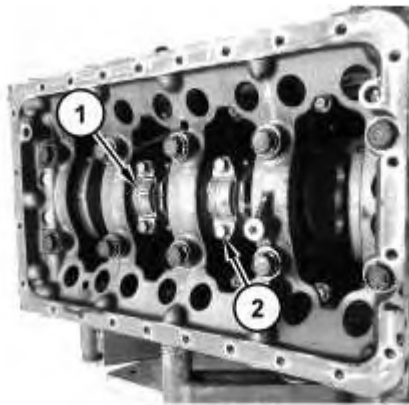

Illustration 7

g02797660

- Install connecting rod cap (1) onto the connecting rod .

Note: Ensure that etched Number (X) on connecting rod cap (1) matches etched Number (X) on the connecting rod. Ensure the correct orientation of the connecting rod cap. The locating tab for the upper bearing shell and the lower bearing shell should be on the same side.

Note: Do not reuse the old connecting rod bolts in order to secure the connecting rod cap.

- For the C3.3B apply clean engine oil to bolt threads and install new bolts (2) to the connecting rod. Tighten bolts (2) to a torque of 69 to 73 N·m (51 to 54 lb ft).
- For the C2.6 apply clean engine oil to bolt threads and install new bolts (2) to the connecting rod. Tighten bolts (2) to a torque of 45 ± 49 N·m (33 ± 36 lb ft).
- Ensure that the installed connecting rod assembly has side play. Rotate the crankshaft in order to ensure that there is no binding.
- Repeat Step 1 through Step 8 in order to install the remaining pistons and connecting rods.

End By:

a. Install engine oil pan.

b. Install cylinder head.

Product: COMPACT WHEEL LOADER

Model: 907H2 COMPACT WHEEL LOADER JRS

Configuration: 907H2 Wheel Loader JRS00001-UP (MACHINE) POWERED BY C3.3B Engine

Disassembly and Assembly C2.6 and C3.3B Engines for Caterpillar Built Machines

Media Number -UENR0137-11

Publication Date -01/08/2015

Date Updated -12/07/2018

i05845101

Pistons and Connecting Rods - Disassemble

SMCS - 1225-015

Disassembly Procedure

Table 1

Required Tools			
Tool	Part Number	Part Description	Qty
A	1U-6683	Ring Expander	1
B	393-2568	Bearing Removal Tool	1
	443-9447	Support Plate	1

Start By:

- a. Remove pistons and the connecting rods.

Note: Make a temporary mark on the components of the piston and connecting rod assembly. Marking the components will ensure that the components of each piston and connecting rod assembly can be reinstalled in the original cylinder. Mark the underside of the piston on the front pin boss. Do not interchange components.

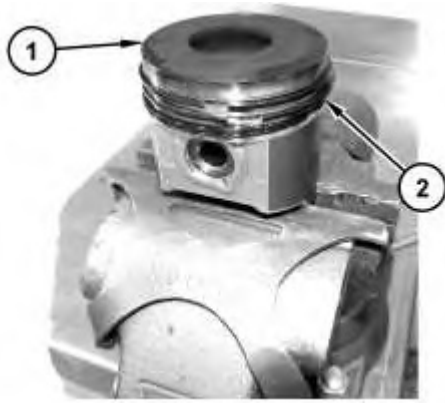

Illustration 1

g02723365

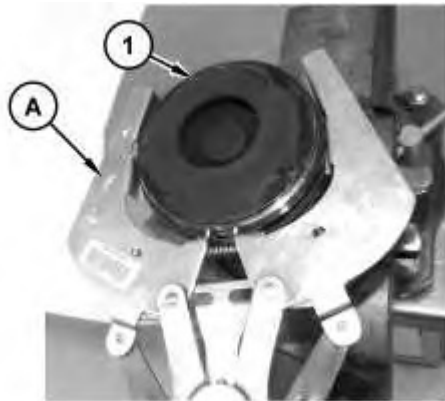

Illustration 2

g02723368

1. Position the piston and connecting rod in a soft jaw vise. Use Tooling (A) to remove three rings (2) from piston (1).
-



Illustration 3

g02723373

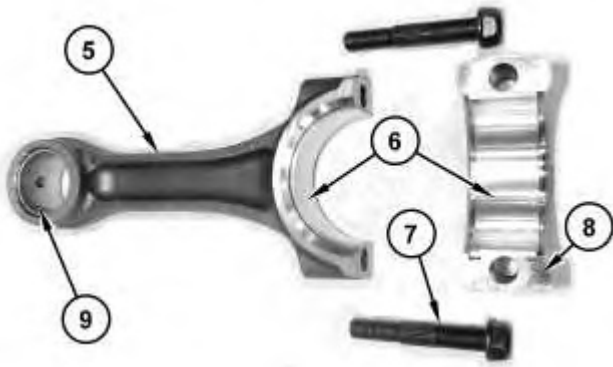

Illustration 4

g02723375

2. Remove retaining ring (4) and remove piston wrist pin (3) from piston (1).

Note: Note the position of the forged Mark (X). The forged mark is for the purposes of correct orientation of the connecting rod assembly and piston assembly.

3. If necessary, remove bolts (7) and connecting rod bearings (6) from connecting rod (5) and connecting rod cap (8). Inspect connecting rod bushing (9).

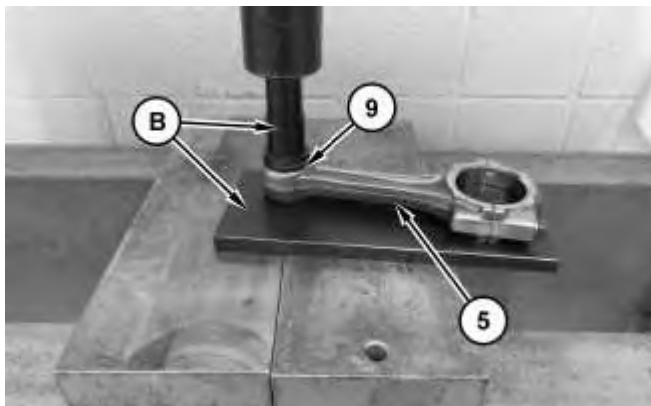

Illustration 5

g03696304

4. Place the piston on a suitable surface with the crown upward. Use Tooling (B) in order to remove connecting rod bushing (9) from connecting rod (5).

5. Inspect the connecting rod for wear and damage. If necessary, replace connecting rod (5) or replace the connecting rod bushing (9).

Note: If the connecting rod or the bush for the piston pin are replaced, refer to Specifications, "Connecting Rods" for the correct procedure.

6. Repeat Step 1 through Step 5 in order to disassemble the remaining pistons and connecting rods.

Product: COMPACT WHEEL LOADER

Model: 907H2 COMPACT WHEEL LOADER JRS

Configuration: 907H2 Wheel Loader JRS00001-UP (MACHINE) POWERED BY C3.3B Engine

Disassembly and Assembly C2.6 and C3.3B Engines for Caterpillar Built Machines

Media Number -UENR0137-11

Publication Date -01/08/2015

Date Updated -12/07/2018

i05845120

Pistons and Connecting Rods - Assemble

SMCS - 1225-016

Assembly Procedure

Table 1

Required Tools			
Tool	Part Number	Part Description	Qty
A	1U-6683	Ring Expander	1
B	393-2568	Bearing Removal Tool	1
	443-9447	Support Plate	1

Note: Refer to Specification UENR0995 "Engine Design" for non-specified engine Torque Values.

Note: The C3.3B has three different piston heights that vary 0.05 mm (0.002 inch) from each. Refer to the following Table 2 to ensure that the same piston height is replaced. If the same piston height is replaced, then the same head gasket thickness can be used. If a different piston height is used, then check the piston height to determine the proper head gasket thickness. Refer to "Cylinder Head - Remove and Install" for the correct head gasket.

Table 2

Code Stamped on Standard Piston	Standard Replacement Piston	0.50 mm Oversized Piston	Code Stamped on Oversized Piston
1J751-2111	387-9833	393-2885	1J751-2190
1J751-2112	387-9834	393-2886	1J751-2191
1J751-2113	387-9835	393-2887	1J751-2192

1. Ensure that all components are clean and free from wear and damage. If necessary, replace any components that are worn or damaged.

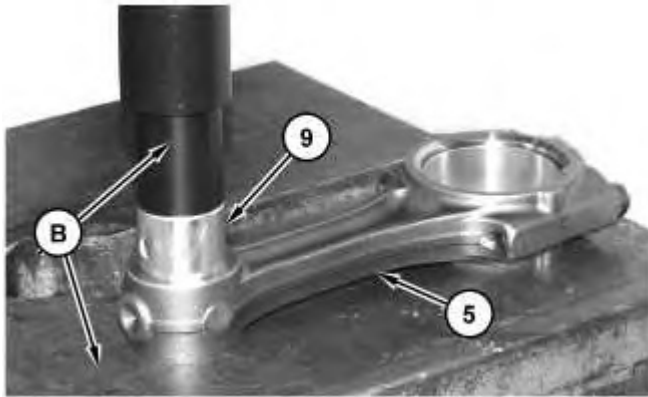

Illustration 1

g03696355

2. Inspect the connecting rod for wear and damage. If necessary, replace connecting rod (5) or replace connecting rod bushing (9) .

Note: If connecting rod (5) or the bushing (9) for connecting rod pin are replaced, refer to Specifications, "Connecting Rods" for the correct procedure.

3. Place the piston on a suitable surface with the crown upward. Use Tooling (B) in order to install connecting rod bushing (9) into connecting rod (5) .

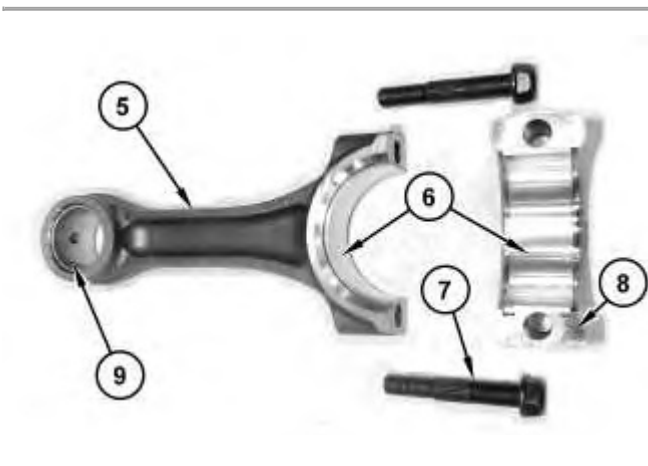

Illustration 2

g02723375

4. Check connecting rod bushing (9) . If necessary, install connecting rod bearings (6) into connecting rod (5) and connecting rod cap (8) . Inspect bolts (7) or replace with new for assembly later.
-

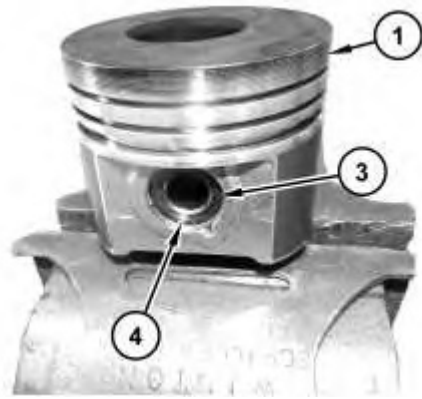

Illustration 3

g02723373

5. Lubricate the bore for the piston wrist pin (3) with clean engine oil.

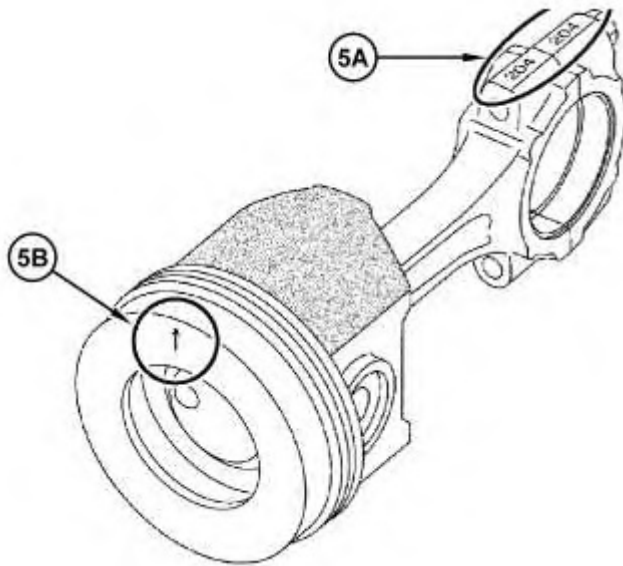

Illustration 4

g02864817

6. Place piston (1) on a suitable surface with the crown downward. Position connecting rod (5) with the markings (5A) on same side as the arrow mark (5B) on top of the piston.
 7. Install piston wrist pin (3) into piston (1) . Install retaining ring (4) .
-

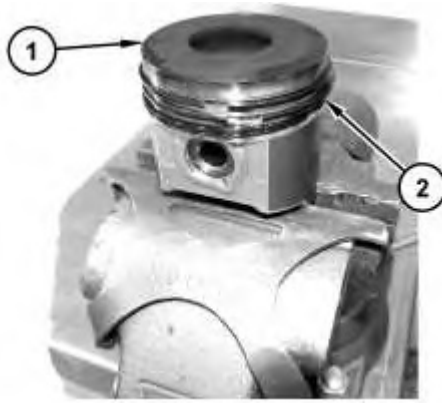

Illustration 5

g02723365

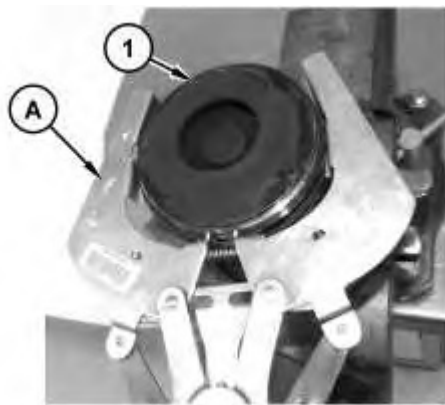

Illustration 6

g02723368

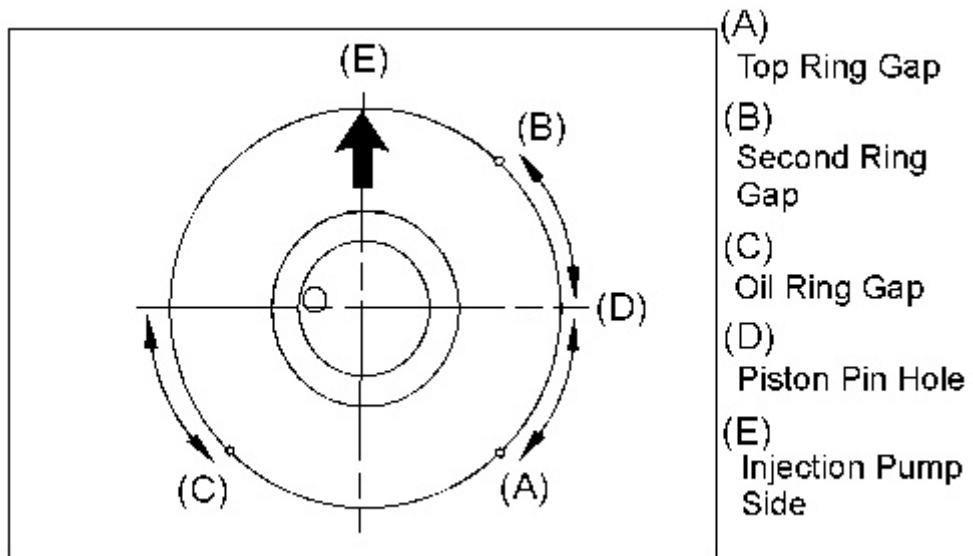

Illustration 7

g02797867

8. Position the connecting rod and piston (1) into a soft jaw vise. Use Tooling (A) in order to install three rings (2) onto piston (1) .
9. If the original piston is assembled, follow Step 9.a through Step 9.e in order to install the piston rings.
 - a. Position the spring for the oil control ring into the oil ring groove in piston (1) . The central wire must be located inside the end of the spring.
 - b. Position the oil control ring with the word "TOP" in the upward position and use Tooling (A) to install over the piston and the spring. Refer to illustration 7.

Note: Ensure that the central wire is 180 degrees from the ring gap.
 - c. Use Tooling (A) to install the intermediate compression ring into the second groove in piston (1) . The word "TOP" must be upward. The chamfer on the inner face must be downward. Refer to illustration 7.
 - d. Use Tooling (A) to install top the compression ring into the top groove in piston (1) . The manufacturing mark must be upward. Refer to illustration 7.
 - e. Position piston ring (2) gaps at 120 degrees away from each other.
10. Repeat Step 2 through Step 9.e for the remaining piston and connecting rod assemblies.

End By: Install pistons and the connecting rods.

Product: COMPACT WHEEL LOADER

Model: 907H2 COMPACT WHEEL LOADER JRS

Configuration: 907H2 Wheel Loader JRS00001-UP (MACHINE) POWERED BY C3.3B Engine

Disassembly and Assembly C2.6 and C3.3B Engines for Caterpillar Built Machines

Media Number -UENR0137-11

Publication Date -01/08/2015

Date Updated -12/07/2018

i06892088

Connecting Rod Bearings - Remove and Install

SMCS - 1219-010

Removal Procedure

Start By:

- a. Remove the engine oil pan.

Note: Refer to Specification UENR0995 "Engine Design" for non-specified engine Torque Values.

NOTICE

Keep all parts clean from contaminants.

Contaminants may cause rapid wear and shortened component life.

NOTICE

Discard all used Connecting Rod fasteners.

Note: If all connecting rod bearings require replacement, the procedure can be carried out on two cylinders at the same time. The procedure can be carried out on the following pairs of cylinders. 1 with 4 and 2 with 3. Ensure that both pairs of the connecting rod bearings are installed before changing from one pair of cylinders to another pair of cylinders. Refer to Disassembly and Assembly, "Connecting Rod Bearings - Install" for the correct procedure.



Suggest:

For more complete manuals. Please go to the home page.

<https://www.ebooklibonline.com>

If the above button click is invalid. Please download this document first, and then click the above link to download the complete manual.

Thank you so much for reading

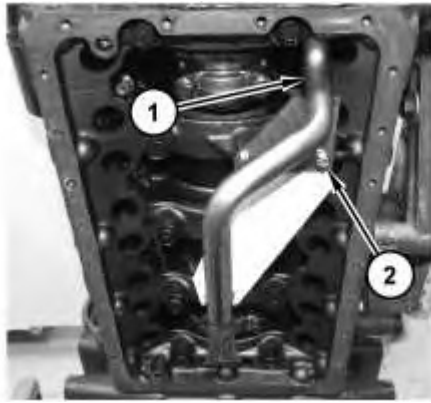

Illustration 1

g02798265

1. Remove bolt (2), the O-ring seal, and oil pump screen (1).

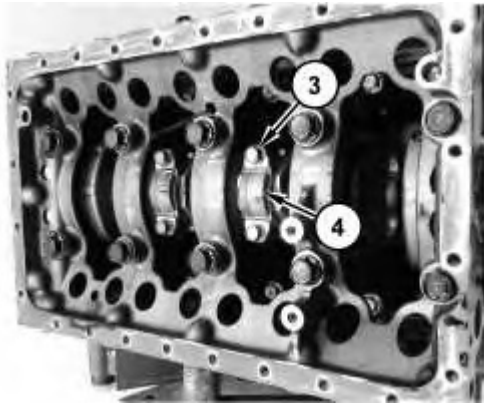

Illustration 2

g02798267

2. The connecting rod and the connecting rod cap should have an etched Number (X) on the side. The number on the connecting rod and the connecting rod cap must match. If necessary, make a temporary mark on the connecting rod and connecting rod cap (4) in order to identify the cylinder number.
3. Remove bolts (3). Remove connecting rod cap (4) from the connecting rod.

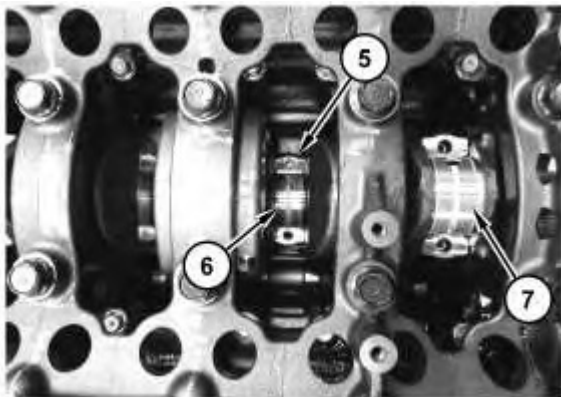

Illustration 3

g02798268

- Carefully push connecting rod (5) into the cylinder bore until connecting rod (5) is clear of the crankshaft. Remove lower bearing shell (7) and then remove upper bearing shell (6) from connecting rod (5). Keep the bearing shells together.
- Repeat Step 3 through Step 4 for the remaining bearing shells.

Installation Procedure

NOTICE

Keep all parts clean from contaminants.

Contaminants may cause rapid wear and shortened component life.

NOTICE

Discard all used Connecting Rod fasteners.

- Ensure that the bearing shells are clean and free from wear and damage. If necessary, replace the bearing shells.

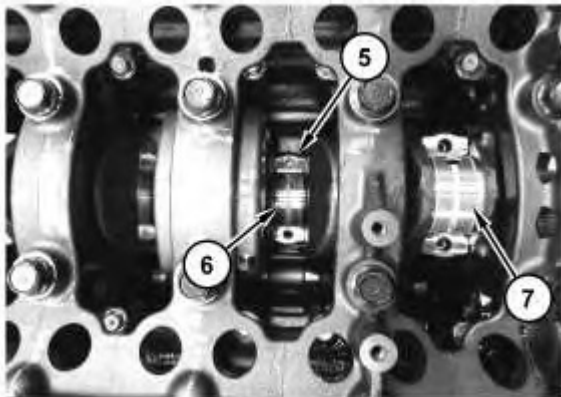

Illustration 4

g02798268

<https://www.ebooklibonline.com>

Hello dear friend!

Thank you very much for reading.

Enter the link into your browser.

The full manual is available for immediate download.

<https://www.ebooklibonline.com>