

Parts Manual
Catalogo Parti Ricambi
Manuel des Pièces de Rechange
Ersatzteilkatalog
Manual de Repuestos

MP20L
MP22



Specify the following information when ordering spare parts:

- **truck model;**
- truck serial number;
- **table N°;**
- *part number of required component;*
- **quantity;**
- *part description*

Per ordinare parti di ricambio specificare:

- **tipo della macchina;**
- *matricola della macchina;*
- **n° della tavola;**
- *numero di codice del particolare richiesto;*
- **quantità di particolari richiesti;**
- *denominazione del particolare richiesto.*

Pour les commander les pièces détachées veuillez préciser:

- **type machine;**
- *n° matricule;*
- **n° plan;**
- *n° code de la pièce;*
- **nombre de pièces;**
- *désignation de la pièce.*

Zum Bestellen von Ersatzteilen bitte folgende Angaben machen:

- **Staplertyp;**
- *Seriennummer der Maschine;*
- **Tafel-Nr.;**
- *Best. Nr. des erforderlichen Teils;*
- **Erforderliche Stückzahl;**
- *Bezeichnung des erforderlichen Teils.*

Para solicitar los repuestos especificar:

- **tipo de la máquina;**
- *matrícula de la máquina;*
- **n° de la máquina;**
- *número de código de la pieza solicitada;*
- **cantidad de piezas solicitadas;**
- *denominación de la pieza solicitada.*

PART SHEET INDEX - INDICE DELLE TAVOLE - INDEX DES TABLES - TAFELVERZEICHNIS - INDICE DE TABLAS	PAGE NO.
COVERS / CARTER / COUVERCLE / DECKEL / TAPAS (SHEET 1.A)	4
ADHESIVE LABELS / TARGHETTE ADESIVE / AUTOCOLLANTS DE SIGNALISATION / ABZ.-BILD / ADESIVOS DE AVISO (SHEET 2.A)	6-7
FRAME BATTERY VERTICAL REMOVAL / TELAIO BATTERIA ESTRAZIONE VERTICALE / CHASSIS BATTERIE VERTICAL EXTRACTION / BATTERIEWECHSEL KONVETIONELLE BATTERIE ENDHAME / BASTIDOR BATERIA EXTRACCION VERTICAL (SHEET 3.A-3.B).....	8-11
FRAME BATTERY LATERAL REMOVAL / TELAIO BATTERIA ESTRAZIONE LATERALE / CHASSIS BATTERIE LATERAL EXTRACTION / BATTERIEWECHSEL SEITLICHER / BASTIDOR BATERIA EXTRACCION LATERAL (SHEET 4.A-4.B).....	12-15
SUPPORTS AND CASTER WHEELS / SUPPORTI E RUOTE PIROETTANTI / SUPPORTS ET ATTELAGE / LAGERN UND RÄDER / SOPORTE Y RUEDAS (SHEET 5.A)	16-17
LOAD WHEELS / RUOTE DI CARICO / ATTELAGES / RÄDER / RUEDAS (SHEET 6.A)	18
TRACTION MOTOR / MOTORE TRAZIONE / MOTEUR TRACTION / ZUGMOTOR / MOTORE DE TRACCION (SHEET 7.A)	19
TRACTION UNIT / GRUPPO TRAZIONE / GROUPE DE TRACTION / ZUGAGGREGAT / GRUPO DE TRACCION (SHEET 8.A).....	20-21
MAGNETIC BRAKE / FRENO ELETTROMAGNETICO / FREIN ELETTROMAGN. / ELEKT ROMAGN. BREMSE / FRENO ELECTROM. (SHEET 9.A)	22
HYDRAULIC SYSTEM / IMPIANTO IDRAULICO / INSTALLATION HYDRAULIQUE / HYDRAULIKANLAGE / INSTALLACION HIDRAULICA (SHEET 10.A)	23
DRAWBAR CONTROL BOX / TIMONE SCATOLA COMANDI / BARRE BOITE DE COMMANDE / DEICHSEL STEUERUNGSBUCHSE (SHEET 11.A-11.B-11.C)	24-29

PART SHEET INDEX - INDICE DELLE TAVOLE - INDEX DES TABLES - TAFELVERZEICHNIS - INDICE DE TABLAS	PAGE NO.
DISTRIBUTOR / CENTRALINA IDRAULICA / DISTRIBUTEUR / STEUERUNG / DISTRIBUIDOR (SHEET 12.A)	30-31
BATTERY CHARGER / CARICA BATTERIA / CHARGUER / AULFLADERÄT / CARGADOR DE BATERIAS (SHEET 13.A).....	32
ELECTRICAL DIAGRAM (MP20L) / SCHEMA ELETTRICO (MP20L) / SCHEMA ELECTRIQUE (MP20L) / SCHALTPLAN (MP20L) / ESQUEMA ELECTRICO (MP20L) (SHEET 14.A).....	33
ELECTRICAL DIAGRAM (MP22) / SCHEMA ELETTRICO (MP22) / SCHEMA ELECTRIQUE (MP22) / SCHALTPLAN (MP22) / ESQUEMA ELECTRICO (MP22) (SHEET 15.A).....	34
WIRING DIAGRAM (MP20L) / SCHEMA COLLEGAMENTI CAVI POTENZA (MP20L) / DIAGRAMMA LIAISON CABLE ELECTRIQUE (MP20L) / ELEKTRTSCHUANLAGEPLAN (MP20L) / ESQUEMA CONEXION CABLE POTENCIA (MP20L) (SHEET 16.A)	35
WIRING DIAGRAM (MP22) / SCHEMA COLLEGAMENTI CAVI POTENZA (MP22) / DIAGRAMMA LIAISON CABLE ELECTRIQUE (MP22) / ELEKTRTSCHUANLAGEPLAN (MP22) / ESQUEMA CONEXION CABLE POTENCIA (MP22) (SHEET 17.A)	36
SHEATH DIAGRAM (MP20L) / SCHEMA COLLEGAMENTI GUAINA (MP20L) / DIAGRAMME LIAISON GAINES (MP20L) / MONTELANLAGEPLAN (MP20L) / ESQUEMA CONEXION VAINA (MP20L) (SHEET 18.A).....	37
SHEATH DIAGRAM (MP22) / SCHEMA COLLEGAMENTI GUAINA (MP22) / DIAGRAMME LIAISON GAINES (MP22) / MONTELANLAGEPLAN (MP22) / ESQUEMA CONEXION VAINA (MP22) (SHEET 19.A).....	38
ELECTRICAL DIAGRAM / SCHEMA ELETTRICO / SCHEMA ELECTRIQUE / SCHALTPLAN / ESQUEMA ELÉCTRICO (SHEET 20.A).....	39
CONSOLE ADAPTER / ADATTATORE PER CONSOLLE / ADAPTATEUR POUR CONSOLE / ADAPTER FÜR KONSOLLE / ADAPTADOR POR CONSOLA (SHEET 21.A)	40
ELECTRIC HORN / CLACKSON MAGGIORATO / KLAXON MAJORE / VERSTAERKTE HUPE / AVISADOR ACUSTICO AUMENTADO(SHEET 22.A).....	41
CONNECTORS, CONTACTS, TOOLS / CONTATTI, CONNETTORI, UTENSILI / CONNECTEURS, CONTACTS, OUTILS / KONNEKTORS, KONTAKTS, WERKZEUG / CONTACTO, CONECTOR, UTENSILIO (SHEET 23.A)	42-43
NUMERICAL INDEX / INDICE NUMERICO / INDEX GENERAL / ALGEMEINER INDEX / INDICE GENERAL.....	44-45

<https://www.ebooklibonline.com>

Hello dear friend!

Thank you very much for reading.

Enter the link into your browser.

The full manual is available for immediate download.

<https://www.ebooklibonline.com>

<https://www.ebooklibonline.com>

Hello dear friend!

Thank you very much for reading.

Enter the link into your browser.

The full manual is available for immediate download.

<https://www.ebooklibonline.com>



Suggest:

For more complete manuals. Please go to the home page.

<https://www.ebooklibonline.com>

If the above button click is invalid. Please download this document first, and then click the above link to download the complete manual.

Thank you so much for reading

COVERS
CARTER
COUVERCLE
DECKEL
TAPAS

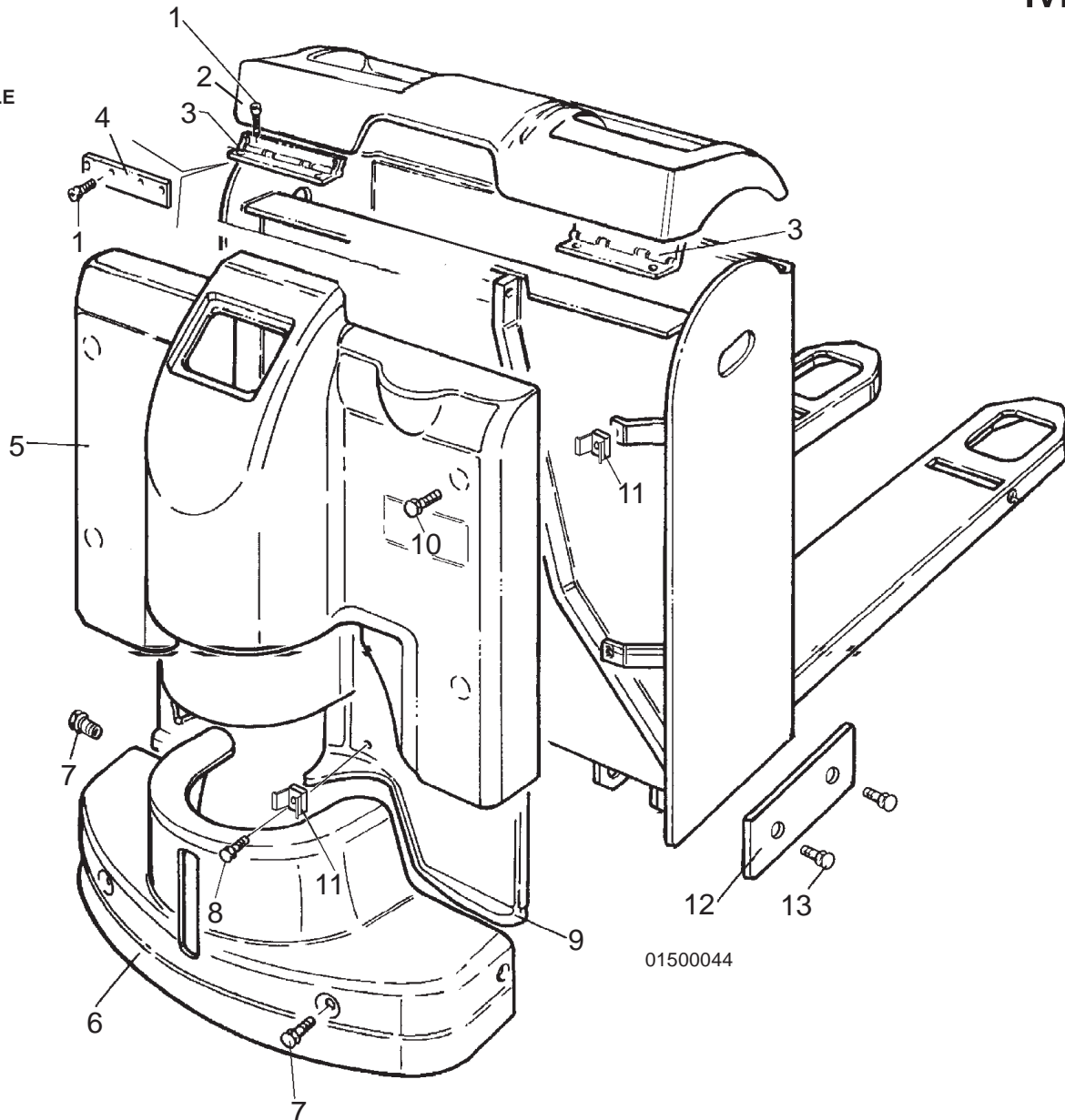

REF	PART N°	Qt.	DESCRIPTION	DESCRIZIONE	DESIGNATION	BENENNUNG	DENOMINACIONES
1	580013990	20	Screw	Vite	Vis	Schraube	Tornillo
2	580022030	1	Cover	Coperchio	Couvercle	Deckel	Tapa
3	272337900	2	Hinge	Cerniera	Charniere	Scharnier	Charnela
4	272338200	2	Plate	Piastrino	Plaque	Platte	Placa
5	524160020	1	Cover	Carter	Couvercle	Deckel	Tapa
6	524167780	1	Cover	Carter inferiore	Couvercle	Deckel	Tapa
7	900014291	4	Screw	Vite	Vis	Schraube	Tornillo
8	580023068	2	Screw	Vite	Vis	Schraube	Tornillo
9	580033475	1	Cover	Carter interno	Couvercle	Deckel	Tapa
10	900014292	4	Screw	Vite	Vis	Schraube	Tornillo
11	580015667	6	Locking nut	Dado in gabbia	Ecrou	Mutter	Tuerca
12	580041287	2	Guard	Protezione	Protection	Shutz	Defensa
13	580006788	4	Screw	Vite	Vis	Schraube	Tornillo

Da matr. / Du matr. / Ab. seriennummer
 From serial N° / Desde la matr.:

Fino a matr. / Jusqu' matr. / Bis zur serien-Nr.
 Until serial N° / Hasta la matr.:

Ad esclusione di / À l'exclusion de
 Mit ausnahme von / With the exception of / Excepto:

Compreso / Avec / Einschließlich
 Including / Con:

D842X01501A