

Section: ENGINE
CRANKCASE

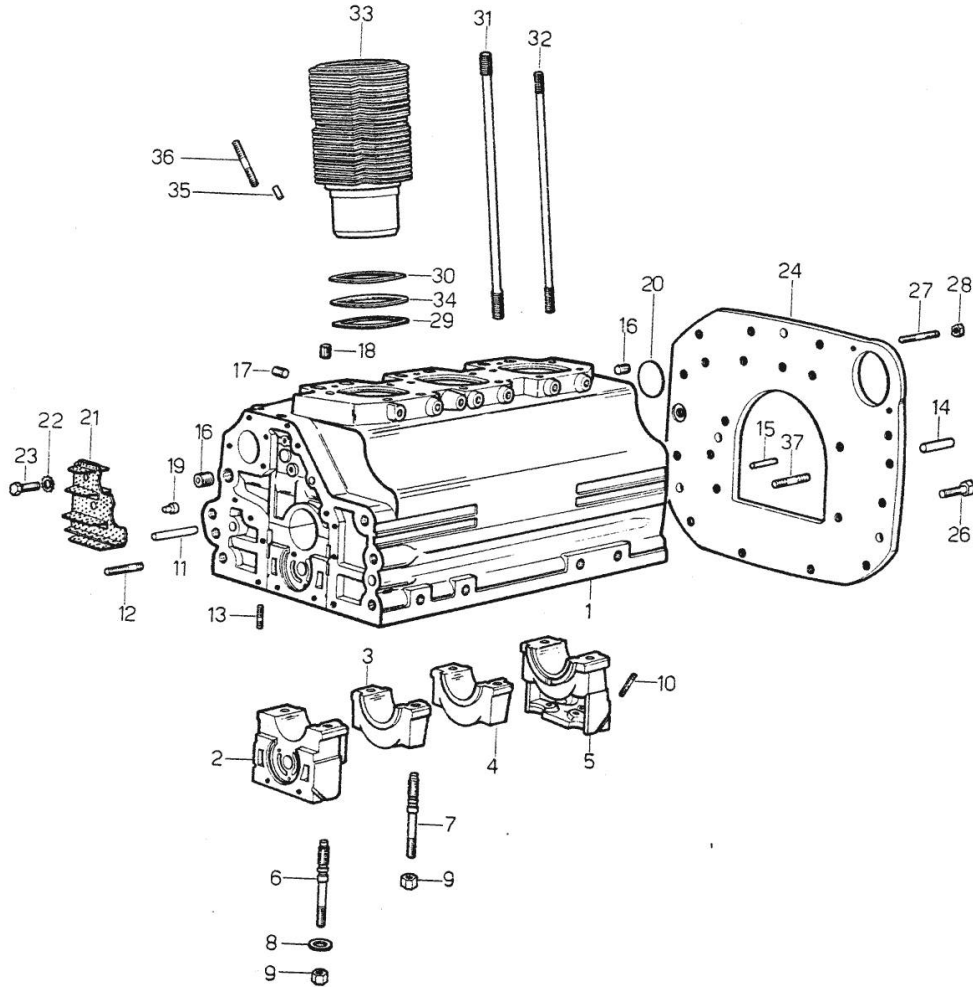

| Fig. | P/n | QTY | Name |
|-----------------------------------|-----------------|-----|--|
| Notes: [MINITAURO 60 C] | | | |
| 0 | 0.038.0050.6 | 1 | old part number |
| 1 | 0.035.1110.4/20 | 1 | FOR INSTALLATION OF ENGINE - 11710 <- old part number 11710 <- ORDER AT SAME TIME - 1x FLANGE 027.1154.0/30 - 1x PLATE 029.1155.2/10 - 1x GASKET 029.1153.0/10 - 1x FLANGE 029.130.0/10# |
| 2 | 0.029.1112.0 | 1 | support |
| 3 | 0.029.1113.0 | 1 | support |
| 4 | 0.029.1113.0 | 1 | support |
| 5 | 0.029.1113.0 | 1 | support |
| 6 | 0.021.1157.0 | 4 | stud bolt |
| 7 | 0.029.1117.0 | 4 | stud bolt |
| 8 | 2.1599.144.0 | 8 | shoulder |
| 9 | 2.1019.026.1 | 8 | special nut m 12 p.1.5 |
| 10 | 0.029.1154.0 | 4 | gasket |
| 11 | 2.1699.116.0 | 1 | pin |
| 12 | 2.0432.018.1 | 6 | stud bolt m 8 p.1.25 / p.1 x 65 |
| 13 | 2.0432.003.1 | 24 | stud bolt m 8 p.1.25 / p.1 x 20 |
| 14 | 2.1652.911.0 | 2 | cylindrical plug 12x25 |
| 15 | 2.1653.708.0 | 2 | pin 8x18 |
| 16 | 2.3130.002.1 | 2 | plug 1/4" gas |
| 17 | 2.3139.001.0 | 3 | plug m 12 p.1.75 |
| 18 | 2.3130.001.1 | 3 | plug 1/8" gas |
| 19 | 2.1699.021.0 | 1 | pin 7.8x8x20 |
| 20 | 2.3170.022.1 | 1 | expansion plug 60 |
| 21 | 0.029.1155.2 | 1 | filter 11710 <- > 11711 |
| 22 | 2.1470.002.2 | 2 | lock washer 6 |
| 23 | 2.0112.003.2 | 2 | screw m 6 p.1 x 12 |
| 24 | 0.029.1130.0/10 | 1 | flange |
| 25 | 2.1470.008.2 | 11 | lock washer 14 |
| 26 | 2.0112.511.1 | 11 | screw m 14 p.2 x 30 |
| 27 | 2.0439.033.1 | 2 | stud bolt m 10x28 |
| 28 | 2.1011.106.2 | 2 | nut m 10 p.1.5 |
| 29 | 2.1589.036.0 | 3 | shim |
| 30 | 2.1589.037.0 | 5 | shim |
| 31 | 0.029.1123.0 | 12 | stud bolt m 12 p.1.5x265 14021 <- |
| 32 | 0.034.1122.0 | 3 | stud bolt |

Section: ENGINE
CRANKCASE

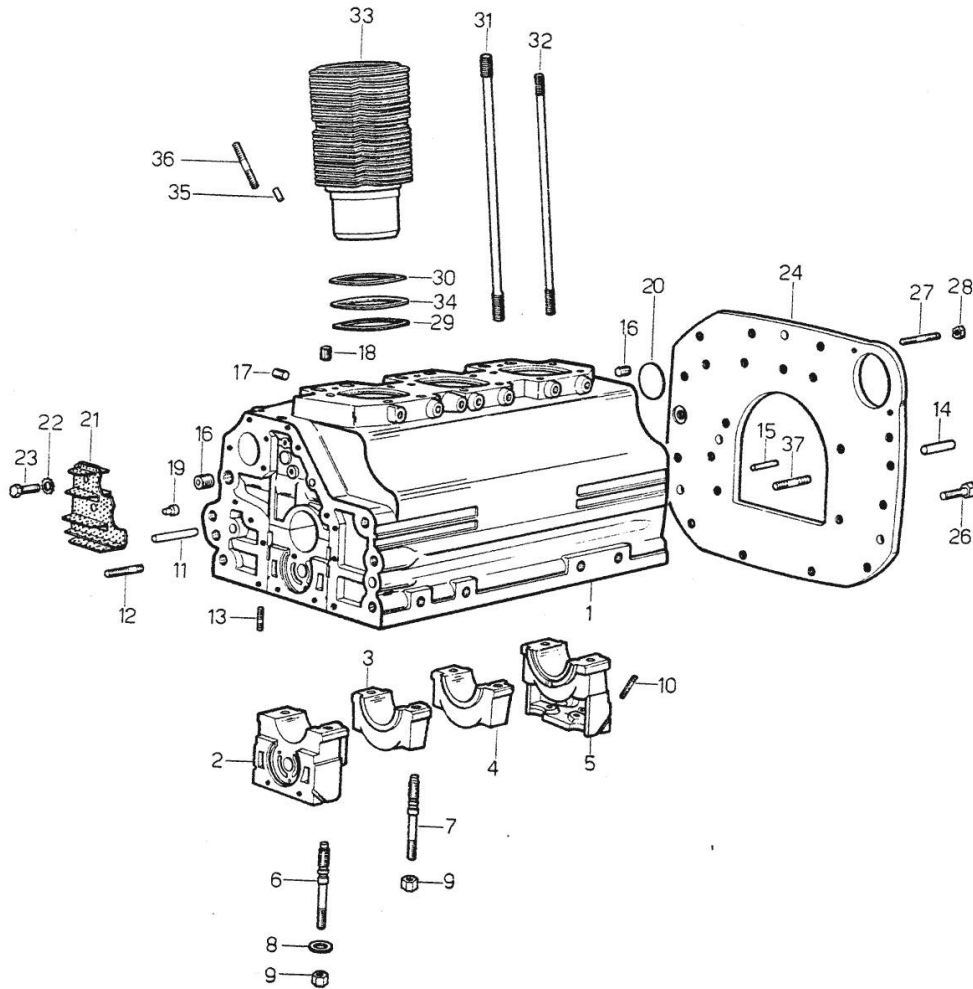

| Fig. | P/n | QTY | Name |
|------|--------------|-----|--|
| 32 | 0.037.1122.0 | 3 | 11898 <- stud bolt 9920 <- E -> 11899 |
| 33 | 0.039.1120.0 | 3 | old part number 11710 <- ORDER ALSO: 2x PUSHROD TUBE 034.1339.6# |
| 34 | 2.1539.055.0 | 3 | oil seal |
| 35 | 2.1653.708.0 | 1 | pin 8x18 |
| 36 | 2.0432.267.1 | 2 | stud bolt m 12 p.1.75-1.25x60 |
| 37 | 2.0432.153.1 | 2 | stud bolt m 10 p.1.5 / p.1.25 x 20 |

Section: ENGINE

TIMING CASE

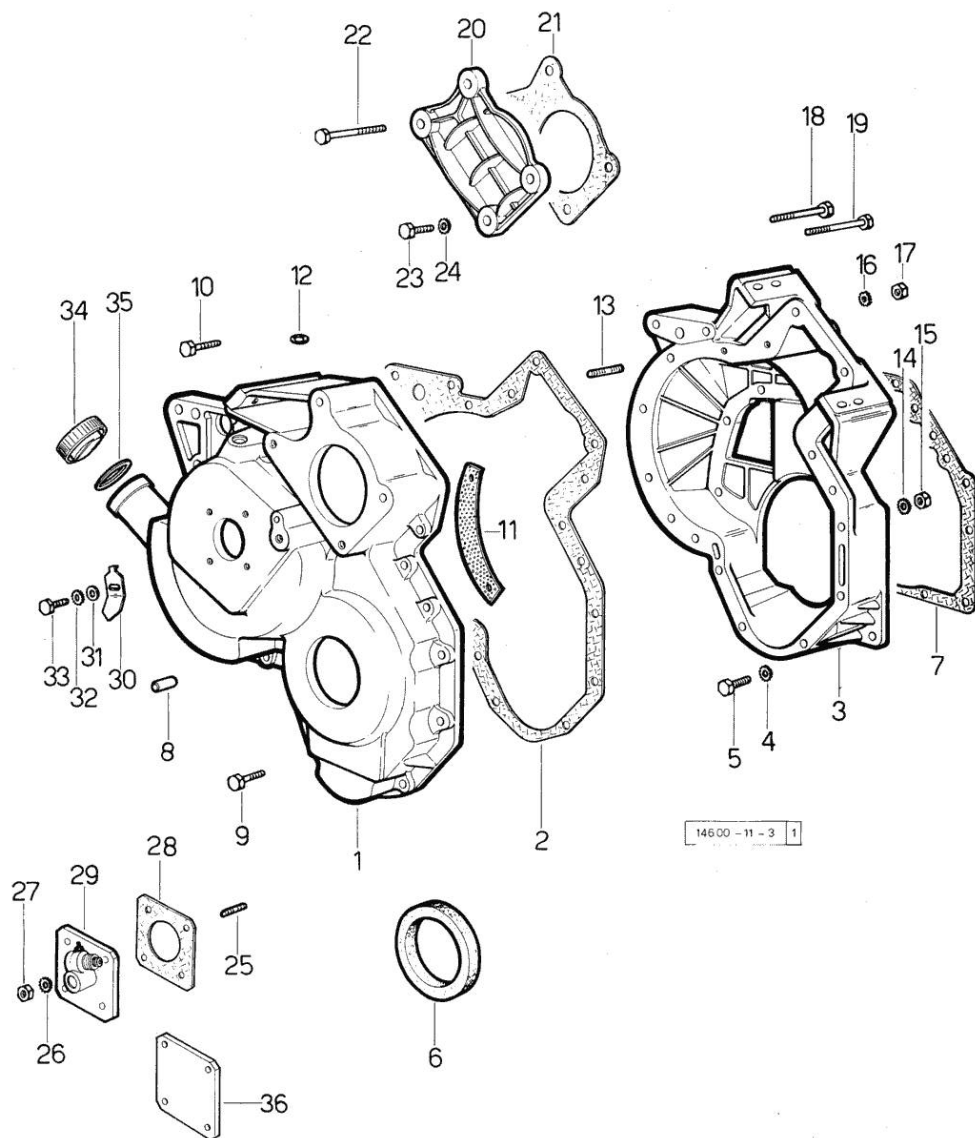

| Fig. | P/n | QTY | Name |
|------|-----|-----|------|
|------|-----|-----|------|

Notes:
[MINITAURO 60 C]

| | | | |
|----|-----------------|----|-----------------------------|
| 1 | 0.027.1155.0/30 | 1 | governor housing |
| 2 | 0.027.1156.0 | 1 | gasket |
| 3 | 0.027.1154.0/30 | 1 | flange |
| 4 | 2.1480.014.1 | 8 | washer 8 |
| 5 | 2.0112.207.2 | 8 | screw m 8 p 1.25 x 20 |
| 6 | 2.1519.010.0 | 1 | special oil seal 58x80x10 |
| 7 | 0.029.1153.0 | 1 | gasket |
| 7 | 0.029.1153.0/10 | 1 | gasket |
| 8 | 2.1653.711.0 | 1 | pin |
| 9 | 2.0122.213.2 | 4 | screw m 8 p.1x35 |
| 10 | 2.0122.222.2 | 1 | screw |
| 11 | 0.027.1152.0/20 | 1 | small plate |
| 12 | 2.1530.028.0 | 1 | oil seal 11.91 x 2.62 |
| 13 | 2.0439.060.2 | 3 | stud bolt m 8 p.1.25-1x22 |
| 14 | 2.1480.014.1 | 15 | washer 8 |
| 15 | 2.1011.405.2 | 15 | nut m 8 p.1 |
| 16 | 2.1480.014.1 | 2 | washer 8 |
| 17 | 2.1011.405.2 | 3 | nut m 8 p.1 |
| 18 | 2.0122.224.1 | 1 | screw |
| 19 | 2.0152.224.1 | 1 | screw |
| 20 | 0.029.1163.0 | 1 | small cover |
| 21 | 0.029.1164.0 | 1 | gasket |
| 22 | 2.0122.229.1 | 2 | screw m 8 x 100 |
| 23 | 2.0122.211.2 | 2 | screw m 8 p.1x30 |
| 24 | 2.1480.016.1 | 4 | washer 12 |
| 25 | 2.0439.055.1 | 4 | stud bolt m 6 p.1 x 18 |
| 26 | 2.1480.012.1 | 4 | washer 6, d128 |
| 27 | 2.1011.103.2 | 4 | nut m 6 p.1 |
| 28 | 0.026.1150.0 | 1 | gasket |
| 29 | 2.7049.210.0/20 | 1 | transmission |
| 30 | 0.038.1150.0 | 1 | index |
| 31 | 2.1310.003.2 | 1 | flat washer 7.4x14 |
| 32 | 2.1470.003.2 | 1 | lock washer 7 |
| 33 | 2.0112.103.1 | 1 | screw m 7 p.1.x12 |
| 34 | 0.022.1135.3 | 1 | plug |
| 35 | 2.1539.048.0 | 1 | special oil seal 20.35x1.78 |
| 36 | 2.1569.048.0 | 1 | gasket |

<https://www.ebooklibonline.com>

Hello dear friend!

Thank you very much for reading.

Enter the link into your browser.

The full manual is available for immediate download.

<https://www.ebooklibonline.com>

Section: ENGINE

CRANKSHAFT

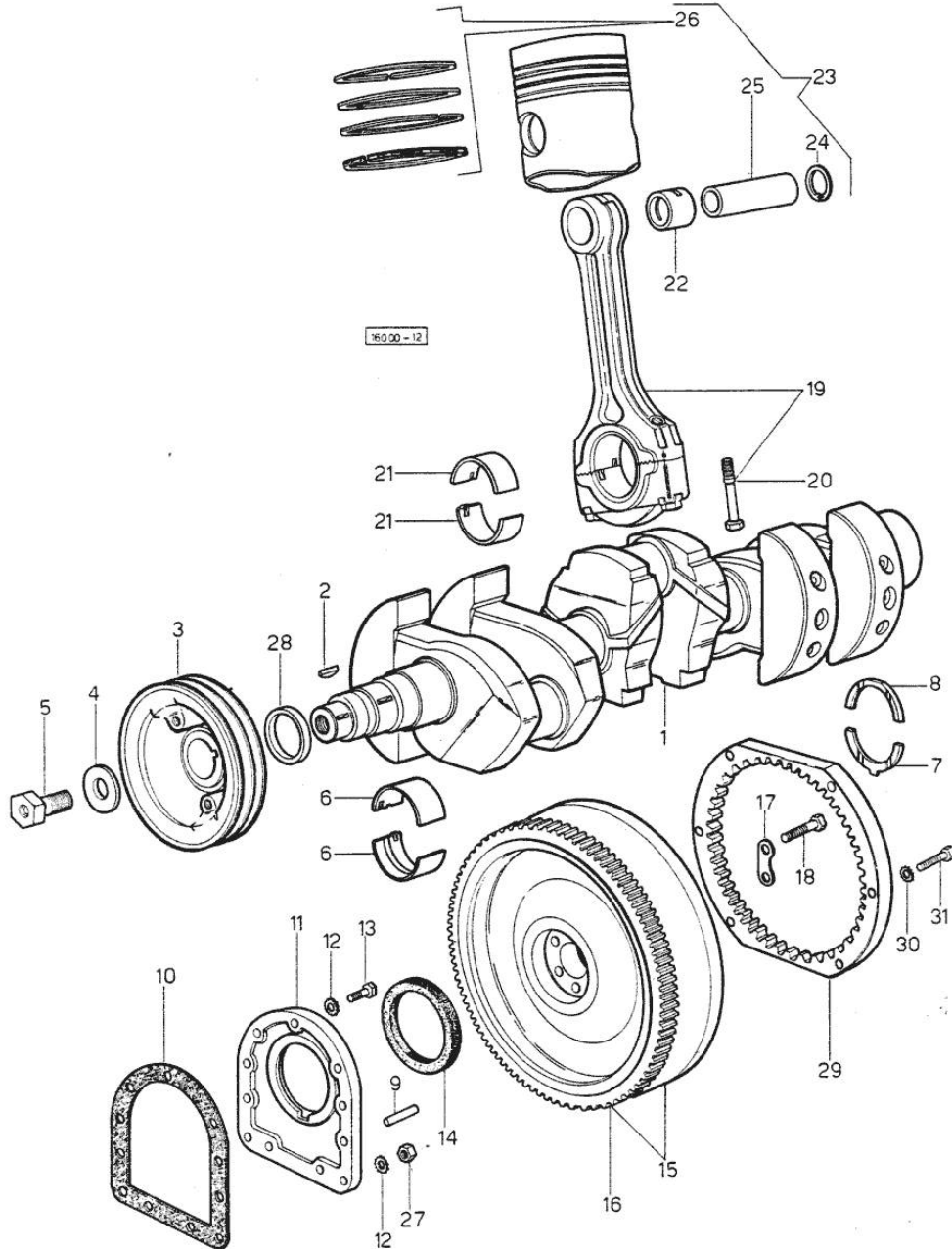

| Fig. | P/n | QTY | Name |
|------------------|-----------------|-----|-----------------------------------|
| Notes: | | | |
| [MINITAURO 60 C] | | | |
| 1 | 0.029.1210.4/30 | 1 | crankshaft => 15572 |
| 1 | 0.029.1210.6 | 1 | crankshaft 15571 <= |
| 2 | 2.1799.002.0 | 1 | stick 10x13 |
| 3 | 0.038.1244.0 | 1 | pulley |
| 4 | 0.001.6020.0 | 1 | shoulder |
| 5 | 2.0129.032.2 | 1 | screw m 24 p.2x45 |
| 6 | 0.029.0066.0 | 8 | main half bushing - mm 1.00 |
| 6 | 0.029.1215.0/10 | 8 | main half bushing |
| 6 | 0.029.1215.7 | 8 | main half bushing - mm 0.25 |
| 6 | 0.029.1215.8 | 8 | main half bushing - mm 0.50 |
| 6 | 0.029.1215.9 | 8 | main half bushing - mm 0.75 |
| 7 | 0.001.4547.0 | 2 | shoulder ring + mm 0.05 |
| 7 | 0.001.4548.0 | 2 | shoulder ring + mm 0.10 |
| 7 | 0.001.4549.0 | 2 | shoulder ring + mm 0.15 |
| 7 | 0.042.1219.0 | 2 | shoulder ring STANDARD |
| 8 | 0.001.4544.0 | 2 | shoulder ring + mm 0.05 |
| 8 | 0.001.4545.0 | 2 | shoulder ring + mm 0.10 |
| 8 | 0.001.4546.0 | 2 | shoulder ring + mm 0.15 |
| 8 | 0.042.1218.0 | 2 | shoulder ring STANDARD |
| 9 | 2.1652.915.0 | 2 | cylindrical plug 12x35 |
| 10 | 0.029.1250.0 | 1 | gasket |
| 11 | 0.029.1240.0 | 1 | flange |
| 12 | 2.1480.015.1 | 9 | washer 10 |
| 13 | 2.0112.309.2 | 9 | screw m 10 p.1.5 x 25 |
| 14 | 2.1519.009.0 | 1 | special oil seal |
| 15 | 0.038.1254.3 | 1 | old part number |
| 16 | 0.029.1242.0 | 1 | crown wheel Z = 120, mm 20 |
| 16 | 0.038.1242.0 | 1 | crown wheel Z = 120, mm 15 |
| 17 | 2.1379.006.0 | 3 | lock-tab 15x15x36,5 |
| 18 | 2.0122.520.1 | 6 | old part number m 14 p.1.5 x 50 |
| 19 | 0.029.1220.3 | 3 | engine connecting rod 15571 <= |
| 19 | 0.039.1220.3/20 | 3 | engine connecting rod => 15572 |
| 20 | 0.002.3910.0 | 6 | screw 15571 <= |
| 20 | 0.039.1250.0 | 6 | screw m 14 p.1.5x63 => 15572 |
| 21 | 0.021.0068.0 | 6 | con.rod half bushing |

Section: ENGINE
CRANKSHAFT

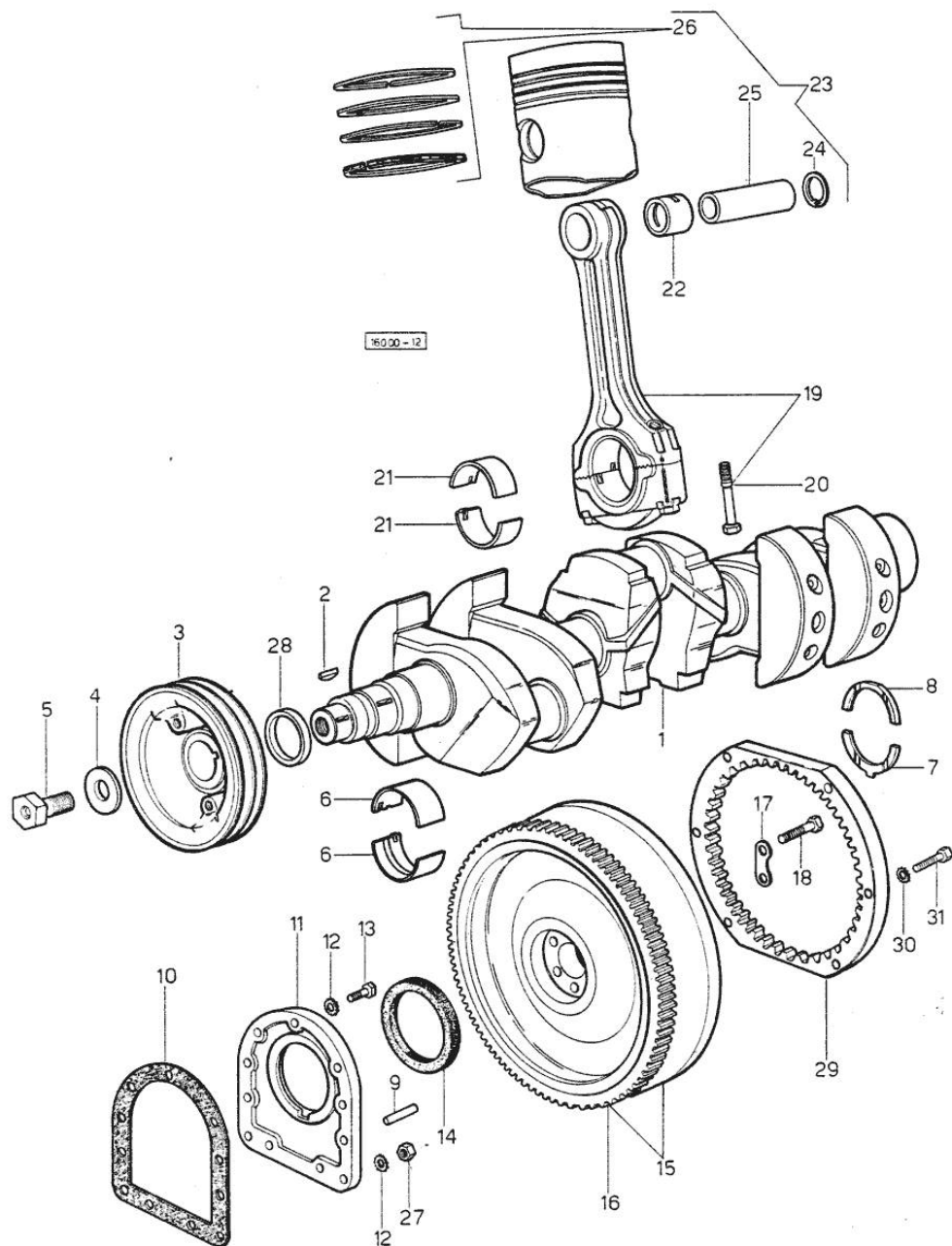

| Fig. | P/n | QTY | Name |
|------|--------------|-----|--|
| 21 | 0.021.1225.0 | 6 | con.rod half bushing STANDARD 15571 <= |
| 21 | 0.021.1225.7 | 6 | con.rod half bushing - mm 0.25 |
| 21 | 0.021.1225.8 | 6 | con.rod half bushing - mm 0.50 |
| 21 | 0.021.1225.9 | 6 | con.rod half bushing - mm 0.75 |
| 21 | 0.039.0068.0 | 6 | con.rod half bushing - mm 1.016 |
| 21 | 0.039.1225.0 | 6 | con.rod half bushing => 15572 |
| 21 | 0.039.1225.7 | 6 | con.rod half bushing -mm 0.254 |
| 21 | 0.039.1225.8 | 6 | con.rod half bushing -mm 0.508 |
| 21 | 0.039.1225.9 | 6 | con.rod half bushing -mm 0.762 |
| 22 | 0.002.4168.0 | 3 | bearing |
| 23 | 0.038.0060.6 | 3 | complete piston |
| 23 | 0.038.0061.6 | 3 | complete piston + mm 0.5 |
| 23 | 0.038.0062.6 | 3 | complete piston + mm 1.0 |
| 24 | 2.1411.014.1 | 6 | circlip 35 |
| 25 | 0.038.1236.0 | 3 | piston pin |
| 26 | 0.038.0054.6 | 3 | piston ring set + mm 1.0 |
| 26 | 0.054.0052.6 | 3 | piston ring set |
| 26 | 0.054.0053.6 | 3 | piston ring set + mm 0.5 |
| 27 | 2.1011.421.2 | 2 | nut m 10 p.1.25 |
| 28 | 0.034.1256.0 | 1 | spacer => 16437 |
| 29 | 0.038.1255.0 | 1 | crown wheel |
| 30 | 2.1470.006.2 | 6 | lock washer 10 |
| 31 | 2.0122.317.1 | 6 | screw |

Section: ENGINE

CAMSHAFT

| Fig. | P/n | QTY | Name |
|------|-----|-----|------|
|------|-----|-----|------|

Notes:
[MINITAURO 60 C]

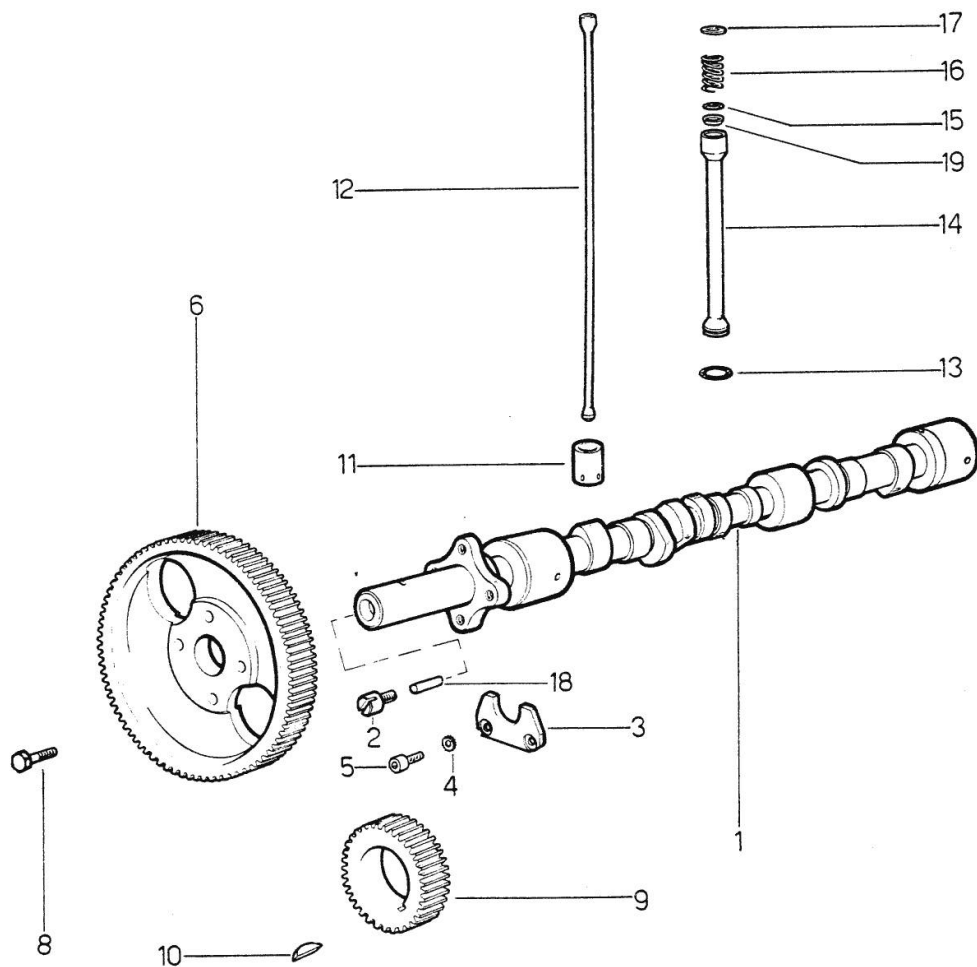

| | | | |
|----|-----------------|---|------------------------------|
| 1 | 0.035.1310.0/10 | 1 | camshaft |
| 2 | 0.027.1350.0/20 | 1 | pin |
| 3 | 0.027.1314.0 | 1 | flange |
| 4 | 2.1470.004.2 | 2 | lock washer 8 |
| 5 | 2.0312.206.2 | 2 | screw m 8 p 1.25 x 20 |
| 6 | 0.035.1321.0 | 1 | gear |
| 8 | 2.0139.006.1 | 4 | screw |
| 9 | 0.029.1320.0 | 1 | gear Z = 45 |
| 10 | 2.1720.010.0 | 1 | key 5x9 |
| 11 | 0.002.3909.0 | 6 | tappets |
| 12 | 0.002.4180.0 | 6 | rod => 9921 - 11898 <= |
| 12 | 0.037.1331.0 | 6 | rod 9920 <= - => 11899 |
| 13 | 2.1539.018.0 | 6 | special oil seal |
| 14 | 0.034.1332.6 | 6 | sleeve 11710 <= |
| 14 | 0.039.1332.0/10 | 6 | sleeve => 11711 |
| 15 | 2.1539.022.0 | 6 | special oil seal 12.37x2.62 |
| 16 | 2.4019.090.1 | 6 | spring 25x34x2.5 11710 <= |
| 16 | 2.4019.149.1 | 6 | spring 14x29x2 => 11711 |
| 17 | 2.1569.037.0 | 6 | gasket |
| 18 | 2.1650.513.0 | 1 | pin 6 x 30 |
| 19 | 0.039.1350.0 | 6 | ring 24697 <= |

Section: ENGINE
CYLINDER HEAD

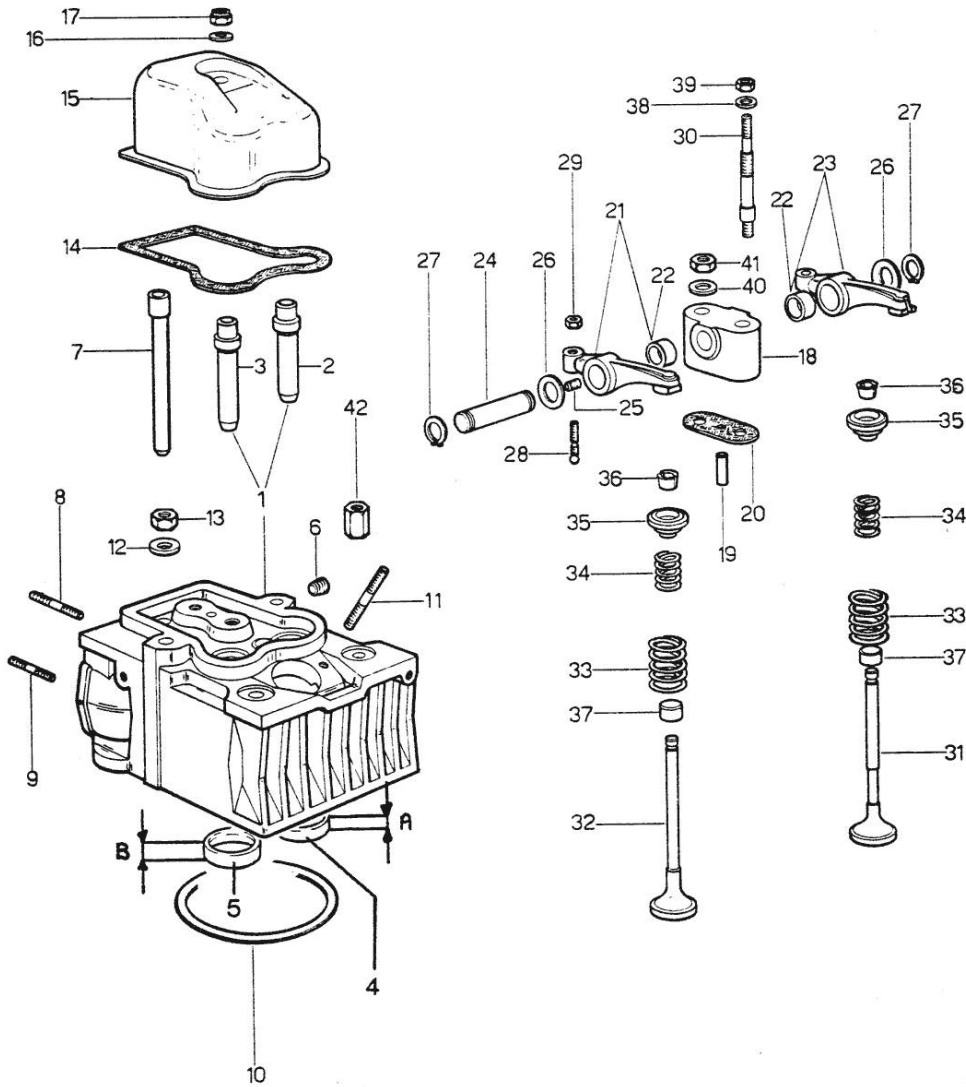

| Fig. | P/n | QTY | Name |
|------|-----------------|-----|--|
| 0 | 0.038.0057.6 | 1 | gasket set - FOR 1 CYLINDER VALVE GRINDING AND PISTON RINGS REPLACEMENT |
| 0 | 0.038.0058.6 | 1 | gasket set - FOR GRINDING VALVES OF ONE CYLINDER |
| 1 | 0.003.5047.6 | 3 | engine head => 11899 |
| 1 | 0.036.1410.6/10 | 3 | old part number 11898 <= |
| 1 | 0.040.1410.3/20 | 3 | old part number => 14022 |
| 2 | 0.029.1417.0 | 3 | valve guide 11898 <= |
| 2 | 0.037.1417.0/10 | 3 | valve guide => 11899 |
| 3 | 0.037.1416.0 | 3 | valve guide => 11899 |
| 3 | 0.037.1417.0/10 | 3 | valve guide 11898 <= |
| 4 | 0.037.1452.0 | 3 | valve seat 41164 <= |
| 4 | 0.037.1452.0/10 | 3 | valve seat => 41165 |
| 5 | 0.037.1451.0 | 3 | valve seat 41164 <= |
| 5 | 0.037.1451.0/10 | 3 | valve seat => 41165 |
| 6 | 2.3130.001.1 | 3 | plug 1/8" gas 11898 <= - => 14022 |
| 6 | 2.3199.026.1 | 3 | plug => 11899 - 14021 <= |
| 7 | 0.029.1418.0 | 6 | sleeve |
| 8 | 2.0432.007.1 | 3 | stud bolt m 8 p.1.25 / p.1 x 30 |
| 8 | 2.0432.022.1 | 1 | stud bolt m 8 p 1.25-1x85 |
| 8 | 2.0432.026.1 | 2 | stud bolt m 8 p.1.25 - 1.00 x 110 |
| 9 | 2.0432.007.1 | 3 | stud bolt m 8 p.1.25 / p.1 x 30 |
| 10 | 2.1569.061.0/10 | 3 | gasket |
| 11 | 2.0439.087.1 | 6 | stud bolt |
| 12 | 2.1599.144.7 | 12 | shoulder ring 12.5x23x4 |
| 13 | 2.1019.025.7 | 10 | special nut |
| 14 | 0.029.1450.0 | 3 | gasket |

Notes:
[MINITAURO 60 C]

Section: ENGINE
CYLINDER HEAD

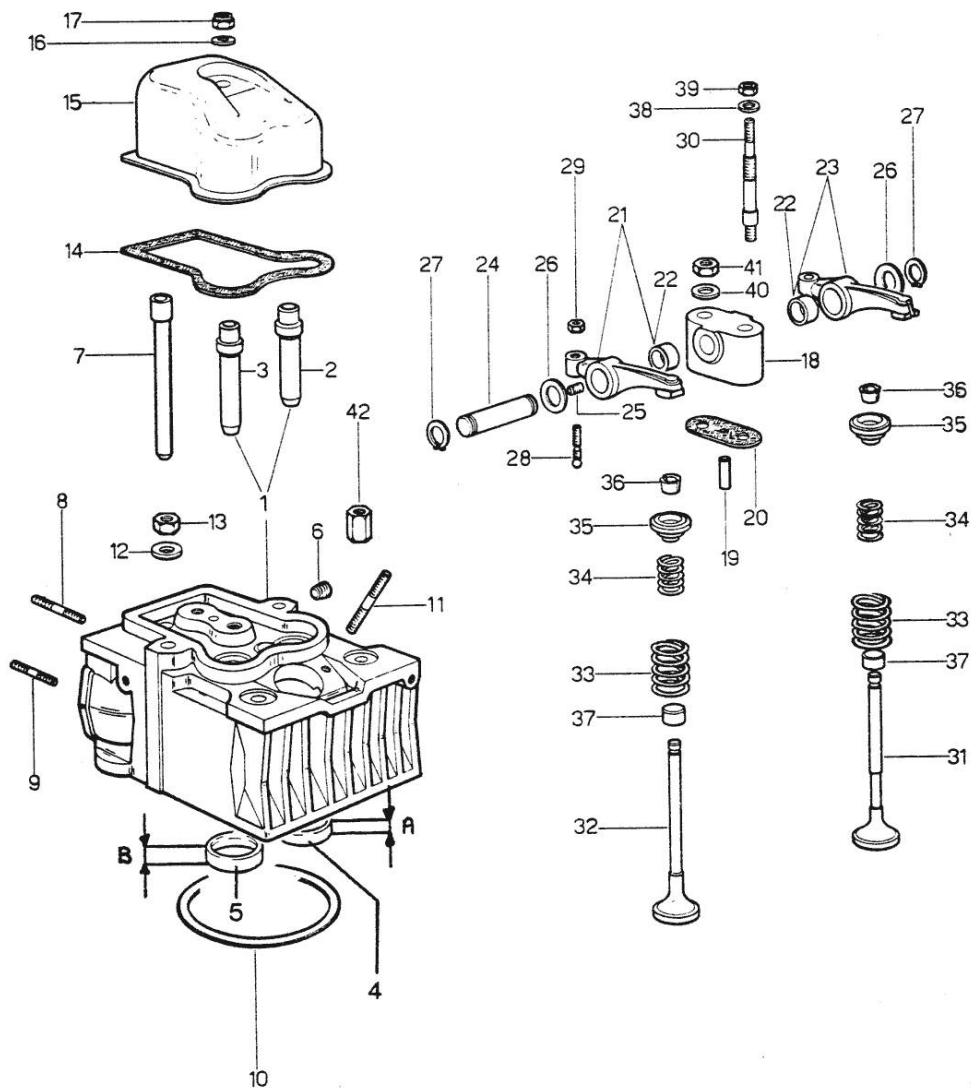

| Fig. | P/n | QTY | Name |
|------|-----------------|-----|---|
| 15 | 0.029.1440.2 | 3 | cap 14021 <= |
| 15 | 0.039.1440.0 | 3 | cap => 14022 |
| 16 | 2.1560.004.0 | 3 | copper gasket 8.2 x 14 |
| 17 | 2.1099.056.1 | 3 | special nut m8 p.1 |
| 18 | 0.034.1430.0 | 3 | support |
| 19 | 0.029.1452.0 | 3 | tube |
| 20 | 0.034.1450.0 | 1 | tappet gasket |
| 21 | 0.002.5937.3/30 | 3 | rocker arm |
| 22 | 2.1559.021.0/40 | 12 | bushing 15x19x22 |
| 23 | 0.002.5936.3/40 | 3 | rocker arm |
| 24 | 0.029.1431.0 | 3 | pin |
| 25 | 2.0512.102.1 | 3 | screw m 6 p.1 x 8 |
| 26 | 2.1599.019.0 | 6 | shoulder ring 19.5x31x2 |
| 27 | 2.1410.055.1 | 6 | circlip 19 |
| 28 | 0.021.1434.0 | 6 | screw |
| 29 | 2.1019.039.1 | 6 | old part number |
| 30 | 0.029.1453.0/10 | 3 | stud bolt 14021 <= |
| 30 | 0.039.1451.0 | 3 | stud bolt => 14022 |
| 31 | 0.029.1421.0/10 | 3 | exhaust valve Ø mm 9 11898 <= |
| 31 | 0.037.1421.0 | 3 | exhaust valve Ø mm 9 => 11899 - 14021 <= |
| 31 | 0.039.1421.0 | 3 | exhaust valve Ø mm 9 => 14022 |
| 32 | 0.029.1420.0/10 | 3 | inlet valve Ø mm 9 11898 <= |
| 32 | 0.039.1420.0 | 3 | inlet valve => 11899 |
| 33 | 2.4019.193.0 | 6 | spring 36.15x55.2x3.2 |
| 34 | 2.4019.194.0 | 6 | spring 22.70x50.7x2.1 |
| 35 | 0.002.9215.0 | 6 | cup |
| 36 | 0.002.9193.0 | 12 | conical valve cotter |
| 37 | 0.021.1453.0/20 | 6 | small cover |
| 38 | 2.1310.006.2 | 3 | flat washer 10.5x21 |
| 39 | 2.1011.421.2 | 3 | nut m 10 p.1.25 |
| 40 | 2.1599.160.7 | 3 | flat washer |
| 41 | 2.1099.035.7 | 3 | special nut |
| 42 | 2.1019.037.7 | 5 | special nut |

Section: ENGINE
LUBRICATION

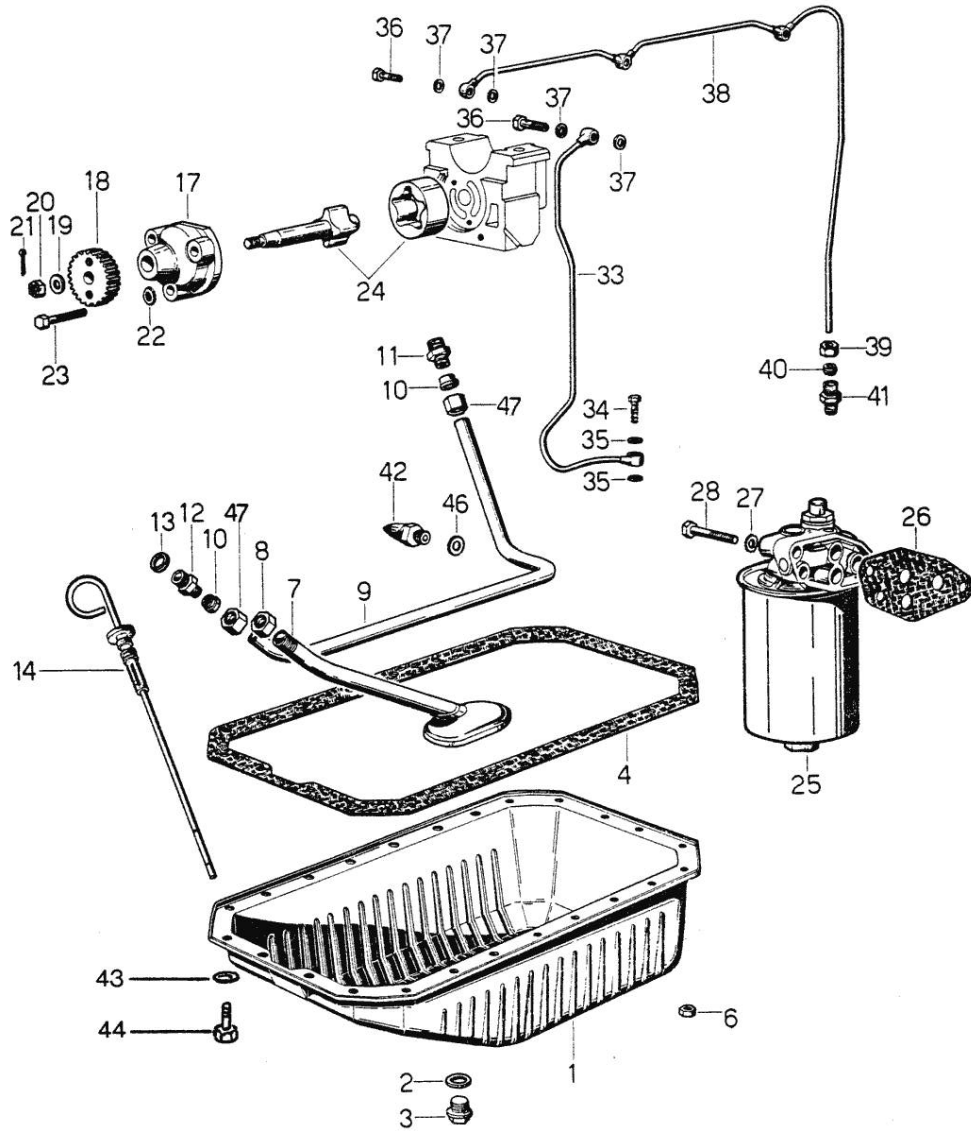

| Fig. | P/n | QTY | Name |
|------|-----------------|-----|-------------------------------------|
| 1 | 0.035.1510.2/10 | 1 | oil sump - IN SHEET STEEL |
| 1 | 0.038.1556.0 | 1 | oil sump - IN CAST IRON |
| 2 | 2.1560.054.0 | 1 | gasket 21 x 26 |
| 3 | 2.3199.001.2 | 1 | plug 1/2" gas |
| 4 | 0.029.1512.2 | 1 | gasket FOR SHEET STEEL OIL TRAY |
| 4 | 0.038.1555.0 | 1 | gasket - WITH CAST IRON OIL SUMP |
| 6 | 2.1011.405.2 | 24 | nut m 8 p.1 |
| 7 | 0.029.1531.3 | 1 | tube |
| 8 | 2.1099.026.1 | 1 | special nut |
| 9 | 0.029.1534.0 | 1 | tube |
| 10 | 2.3359.004.2 | 2 | ring |
| 11 | 2.3319.014.1 | 1 | pipe union |
| 12 | 2.3319.013.1 | 1 | pipe union |
| 13 | 2.1560.013.0 | 1 | gasket 18.2x22 |
| 14 | 0.038.1513.3 | 1 | dipstick |
| 17 | 0.029.1520.0 | 1 | pump casing |
| 18 | 0.029.1521.0/10 | 1 | gear |
| 19 | 2.1310.006.2 | 1 | flat washer 10.5x21 |
| 20 | 2.1021.321.1 | 1 | castellated nut |
| 21 | 2.1690.210.0 | 1 | split pin A2x25 |
| 22 | 2.1470.004.2 | 3 | lock washer 8 |
| 23 | 2.0112.215.2 | 3 | screw m 8 p.1.25 x 40 |
| 24 | 0.029.1522.3/10 | 1 | shaft |
| 25 | 2.4419.130.0/10 | 1 | oil filter ☞ 01.00.6 |
| 26 | 0.037.1552.0/10 | 1 | gasket |
| 27 | 2.1480.015.1 | 3 | washer 10 |
| 28 | 2.0112.315.2 | 1 | screw m 10 p.1.5 x 40 |
| 28 | 2.0112.320.2 | 2 | screw m 10 p.1.5 x 55 |
| 36 | 2.3339.001.0 | 3 | pipe fitting m 10 p.1 |
| 37 | 2.1560.006.0 | 6 | gasket 10.2 x 16 |
| 38 | 0.038.1536.3/10 | 1 | tube |
| 39 | 2.3360.002.1 | 1 | union nut m 10 |
| 40 | 2.3350.002.1 | 1 | nosepiece 6, d128 |
| 41 | 2.3319.002.1 | 1 | pipe fitting |
| 42 | 2.7099.020.0/10 | 1 | pressure switch |
| 43 | 2.1470.004.2 | 24 | lock washer 8 |



Suggest:

For more complete manuals. Please go to the home page.

<https://www.ebooklibonline.com>

If the above button click is invalid. Please download this document first, and then click the above link to download the complete manual.

Thank you so much for reading

Section: ENGINE
LUBRICATION

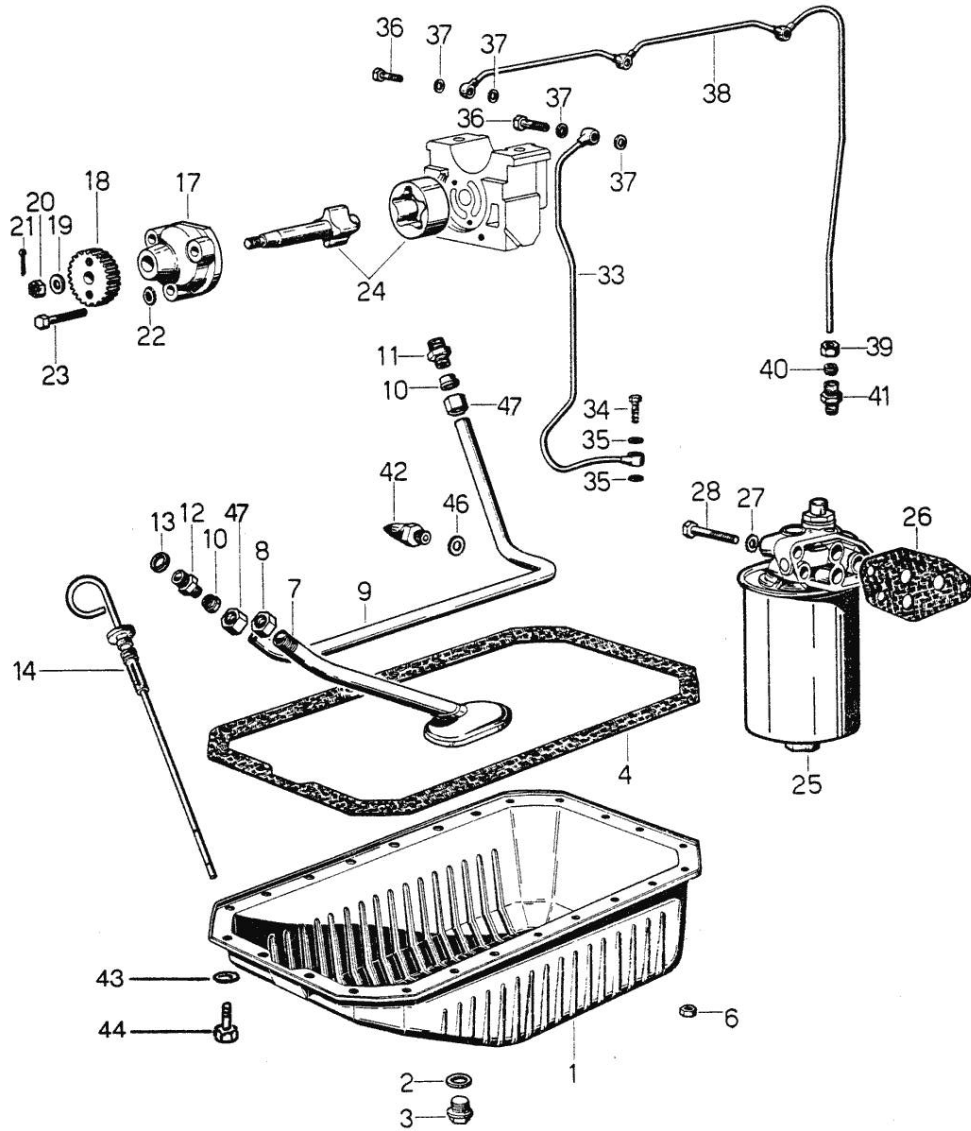

| Fig. | P/n | QTY | Name |
|------|--------------|-----|-----------------------|
| 44 | 2.0112.209.2 | 22 | screw m 8 p 1.25 x 25 |
| 44 | 2.0112.222.2 | 2 | screw m 8 p.1.25x65 |
| 46 | 2.1560.008.0 | 1 | gasket 12.2 x 18 |
| 47 | 2.3369.009.1 | 2 | union nut |

DETAILS OF OIL FILTER

| Fig. | P/n | QTY | Name |
|------|-----|-----|------|
|------|-----|-----|------|

Notes:
[MINITAURO 60 C]

| | | | |
|---|-----------------|---|---------------------|
| 0 | 2.4419.130.0/10 | 1 | oil filter |
| 1 | 2.4419.150.1 | 1 | oil filter element |
| 2 | 2.4419.130.3 | 1 | gasket |
| 3 | 2.1530.045.0 | 1 | oil seal 17.86x2.62 |
| 4 | 2.4419.130.2 | 1 | valve |
| 5 | 0.000.0000.1 | 1 | cannot be supplied |

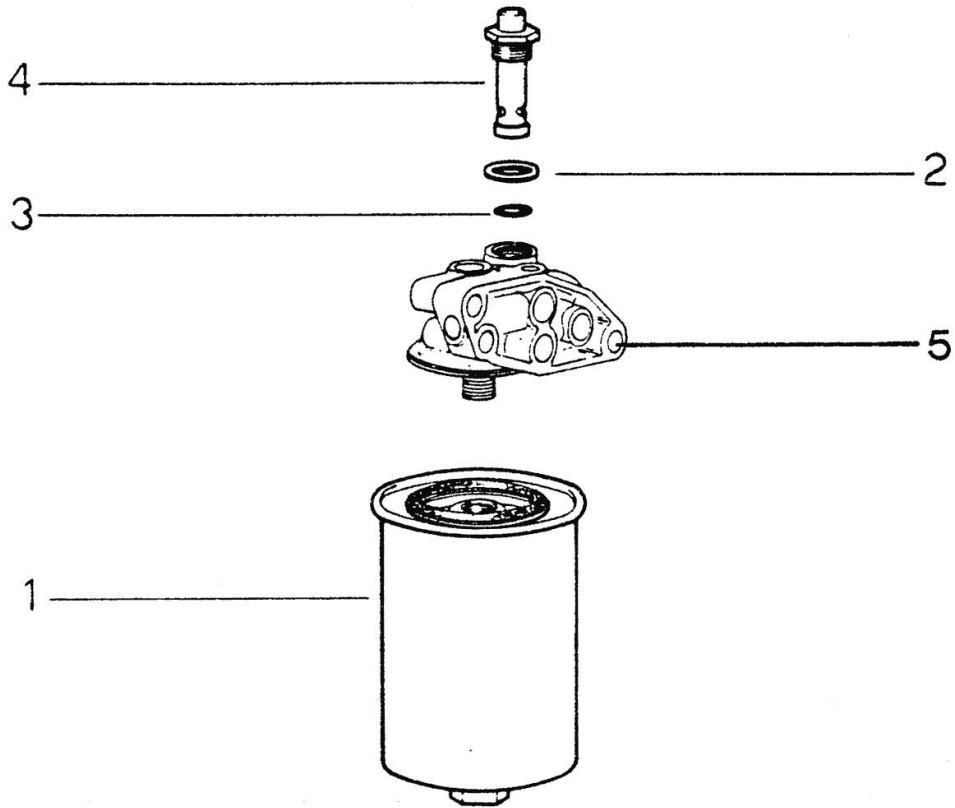

<https://www.ebooklibonline.com>

Hello dear friend!

Thank you very much for reading.

Enter the link into your browser.

The full manual is available for immediate download.

<https://www.ebooklibonline.com>