

Section: ENGINE
CRANKCASE

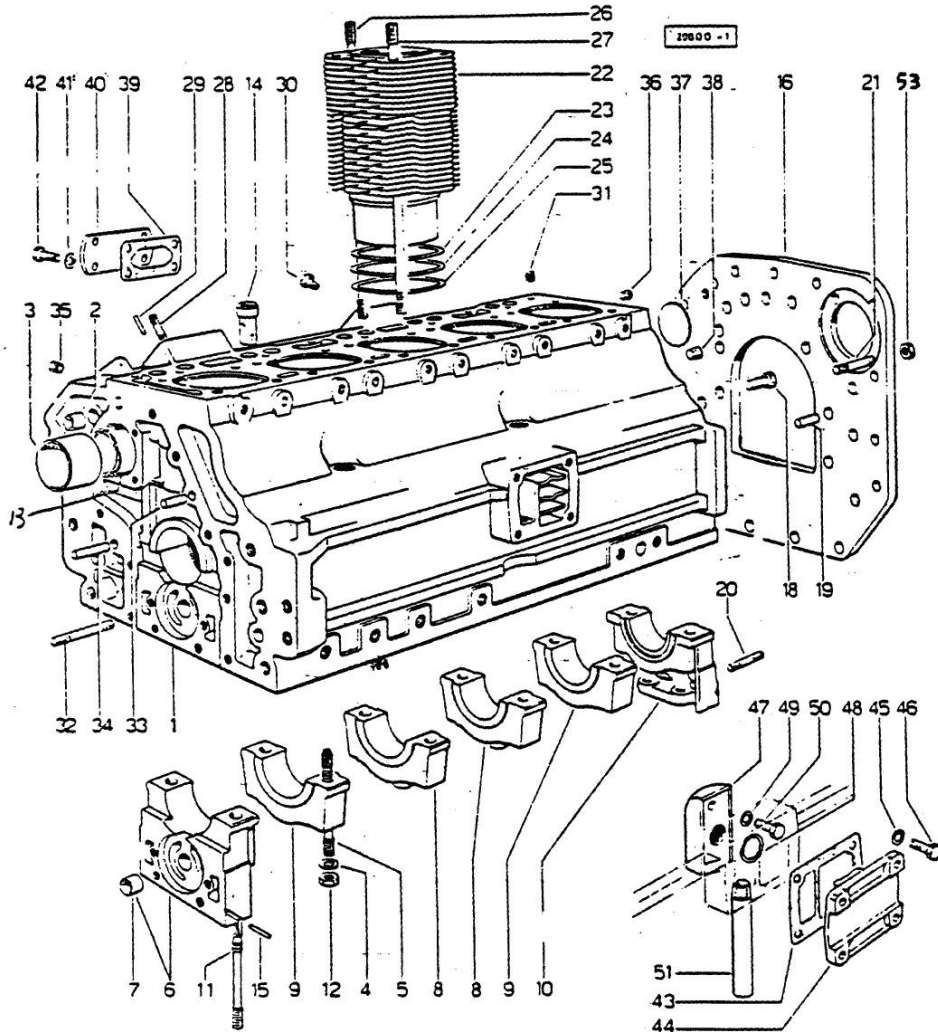

Fig.	P/n	QTY	Name
Notes: [JAGUAR 100 EXPORT]			
0	0.042.0050.6	1	gasket set
1	0.048.1110.4/70	1	crankcase 11704 <= ORDER ALSO: 045.1240-2.0112.309.2-2.1474.010.1
1	0.048.1153.4/10	1	old part number EXPORT USA 11704 <= ORDER ALSO: 045.1240-2.0112.309.2-2.1474.010.1
2	2.1559.111.0/20	2	special bushing
3	0.037.1155.0	1	bushing
4	2.1599.144.7	12	shoulder ring 12.5x23x4
5	0.029.1117.0	8	stud bolt
6	0.052.1112.3	1	support
7	2.1559.090.0/10	1	bushing 14.24x19.06x27
8	0.037.1114.0	2	support
9	0.052.1113.0	2	support
10	0.052.1116.0	1	support
11	0.021.1157.0	4	stud bolt
12	2.1019.026.7	12	special nut m 12 p.1.5
13	2.1559.149.0	1	special bushing
14	0.044.1156.0	10	special bushing
15	0.029.1154.0/10	4	gasket
16	0.042.1130.0	1	flange
18	2.0112.513.2	11	screw m 14 p.2 x 35
19	2.1651.911.0	2	cylindrical plug
20	2.0432.153.7	2	stud bolt m 10 p.1.5 / p.1.25 x 20
21	2.0432.257.7	2	stud bolt m 12 p.1.75 - 1.25 x 30
22	0.044.1120.0/40	5	engine cylinder
23	2.1589.052.0	10	shoulder ring 115x123x0.2
24	2.1589.051.0	5	shoulder ring 116x123x0.1
25	2.1569.076.0	5	gasket 116x123x0.5
26	0.041.1123.0/10	5	stud bolt
27	0.039.1122.0	20	stud bolt m 12 p.1.5x310
28	2.0432.003.7	8	stud bolt m 8 p.1.25 / p.1 x 20
29	2.1651.306.0	2	cylindrical plug
30	0.071.1151.3/10	5	valve
31	2.3130.001.1	4	plug 1/8" gas
32	2.0432.025.7	2	stud bolt m 8 p.1.25 - 1.00 x 100
33	2.1651.711.0	1	pin 8 x 14
34	2.1699.114.0	1	pin 8x55
35	2.3139.001.1	5	plug
36	2.3130.002.1	1	plug 1/4" gas

Section: ENGINE
CRANKCASE

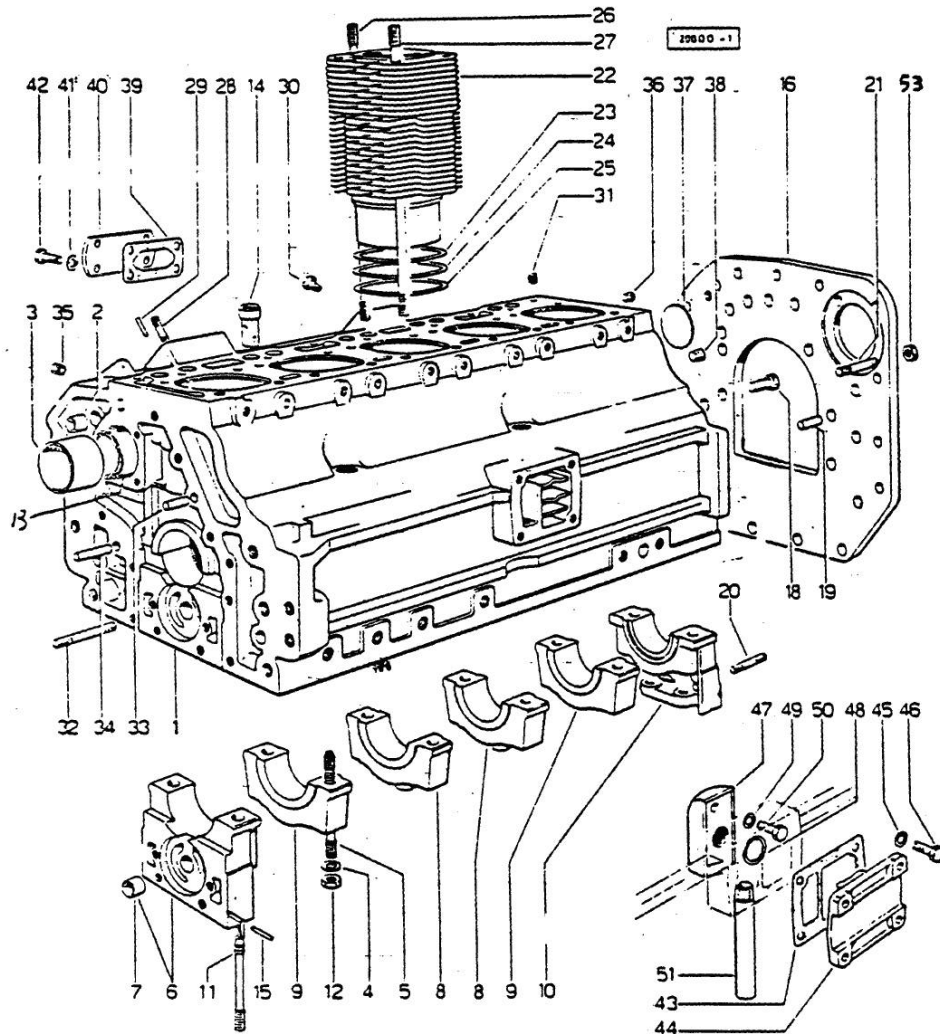

Fig.	P/n	QTY	Name
37	2.3170.022.1	1	expansion plug 60
38	2.3130.003.1	2	plug 3/8" gas
39	0.044.1151.0	2	gasket
40	0.044.1164.2/10	2	small cover
41	2.1310.004.2	8	flat washer 8.4x17
42	2.0112.204.2	6	screw m 8 p.1.25x14
43	0.044.1153.0/10	1	gasket
44	0.044.1154.0	1	cover
45	2.1480.014.1	4	washer 8
46	2.0112.209.2	4	screw m 8 p 1.25 x 25
47	0.044.1155.2/20	1	cover
48	0.071.1156.0	1	special oil seal
49	2.1480.014.1	1	washer 8
50	2.0312.206.2	1	screw m 8 p 1.25 x 20
51	0.044.1152.0/10	1	tube
52	2.1011.207.2	2	nut m 12 p.1.5

Section: ENGINE
TIMING CASE

Fig.	P/n	QTY	Name
------	-----	-----	------

Notes:
[JAGUAR 100 EXPORT]

1	0.048.1131.0	1	flange
2	0.041.1153.0/10	1	gasket
3	2.0112.209.2	5	screw m 8 p 1.25 x 25
4	2.1480.014.1	5	washer 8
5	2.0119.034.2	1	screw m 14 p.2x20
6	2.1560.010.0	1	gasket 14.2 x 20
7	2.0112.207.2	1	screw m 8 p 1.25 x 20
8	2.1480.014.1	1	washer 8
9	0.041.1152.0/10	1	gasket
10	2.1519.010.0	1	special oil seal 58x80x10
11	0.048.1132.0/10	1	guard
11	0.048.1132.0/40	1	guard => 5032 <= => 5033
12	2.0112.217.2	5	screw m 8 p.1.25 x 45
13	2.1480.014.1	5	washer 8
14	2.1560.003.0	2	copper gasket 8.2 x 12
15	2.1011.405.2	2	nut m 8 p.1
16	2.1480.014.1	2	washer 8
17	2.0112.211.2	2	screw m 8 p.1.25 x 30
18	2.0112.222.2	4	screw m 8 p.1.25x65
19	2.1480.014.1	4	washer 8
20	0.041.1158.0	1	index
21	2.1310.004.2	1	flat washer 8.4x17
22	2.0112.204.2	1	screw m 8 p.1.25x14
23	0.048.1151.0/10	1	gasket
24	0.048.1150.0/20	1	cover
25	2.1560.006.0	4	gasket 10.2 x 16
26	2.0112.313.2	1	screw m 10 p.1.5 x 35
26	2.0112.315.2	3	screw m 10 p.1.5 x 40
27	0.041.1154.0	1	gasket
28	2.0432.015.7	1	stud bolt m 8 p.1.25-1x50
29	2.0432.028.7	3	stud bolt m 8 p.1.25-1x130
30	2.1653.717.0	1	pin 8 x 40
31	0.041.1159.0/10	1	filter
32	2.1411.012.1	1	circlip 30
33	0.041.1135.4	1	plug 1" gas
34	2.1569.072.0	1	gasket 32 x 39.5 x 2
35	2.0112.004.2	2	screw m 6 p.1 x 14
36	0.037.1151.0/10	1	cover
37	2.1579.191.2	4	spacer 8.5 x 18 x 20

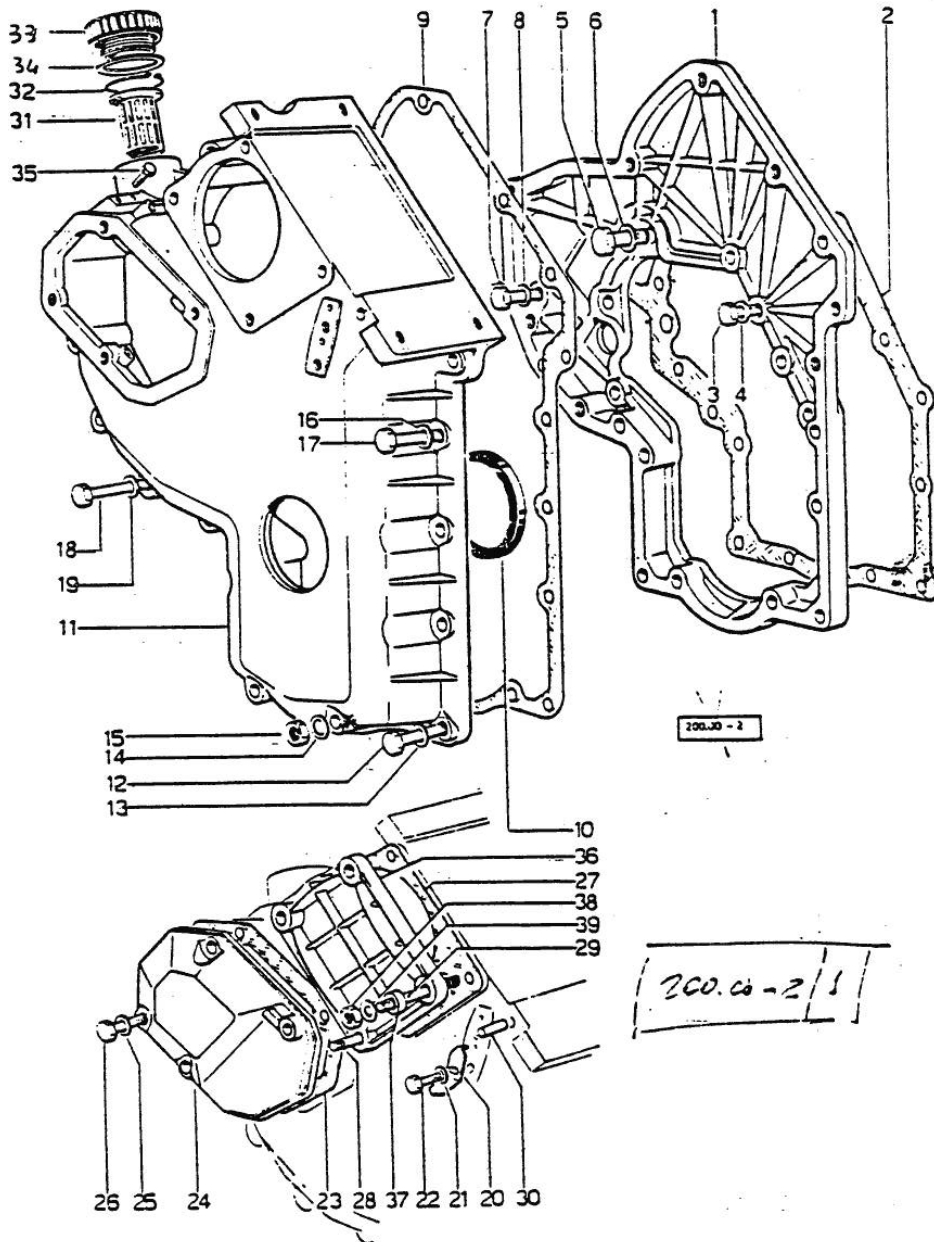

<https://www.ebooklibonline.com>

Hello dear friend!

Thank you very much for reading.

Enter the link into your browser.

The full manual is available for immediate download.

<https://www.ebooklibonline.com>

Section: ENGINE
TIMING CASE

Fig.	P/n	QTY	Name
38	2.1011.405.2	4	nut m 8 p.1
39	2.1310.004.2	4	flat washer 8.4x17

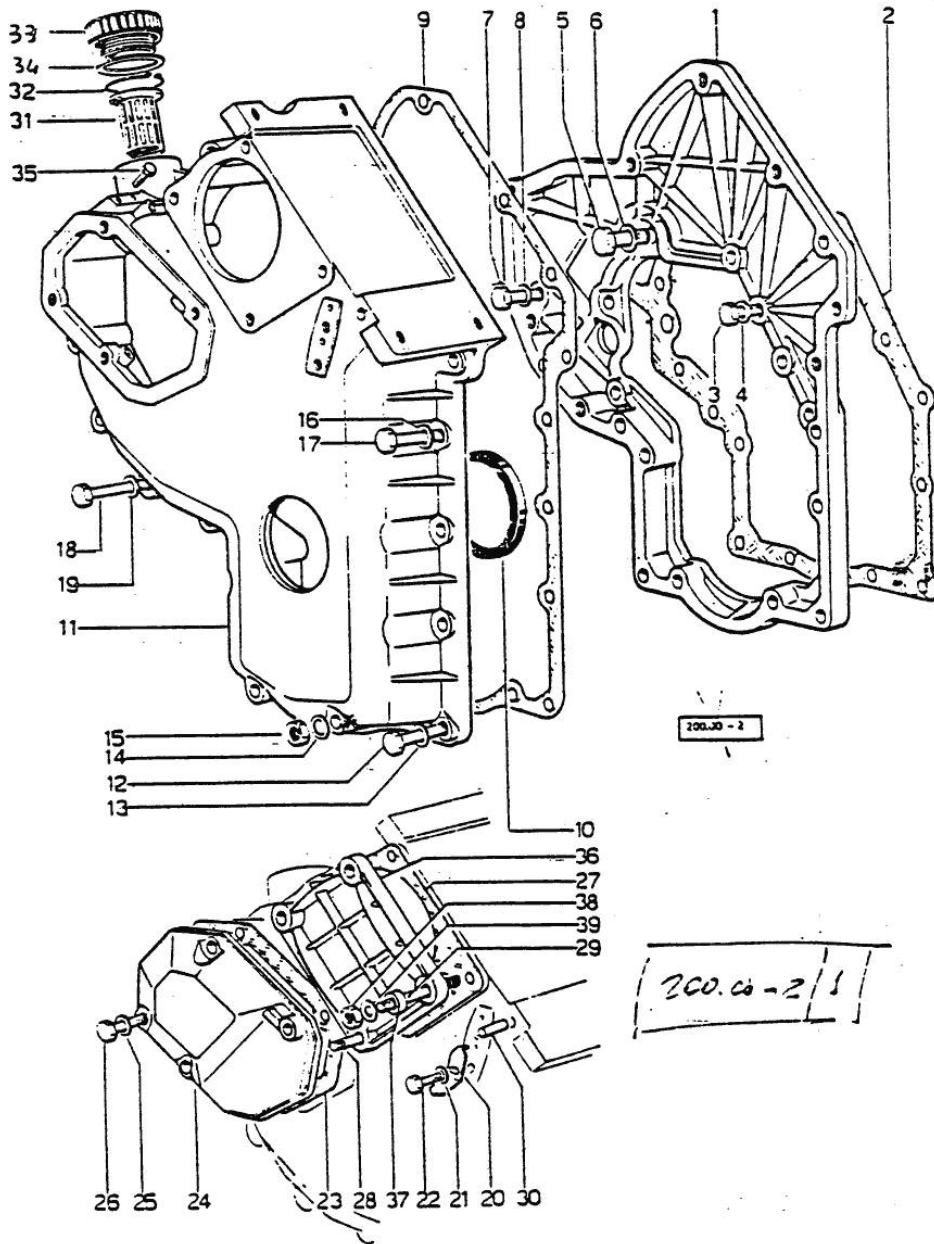

Section: ENGINE
CRANKSHAFT

Fig.	P/n	QTY	Name
------	-----	-----	------

Notes:

[JAGUAR 100 EXPORT]

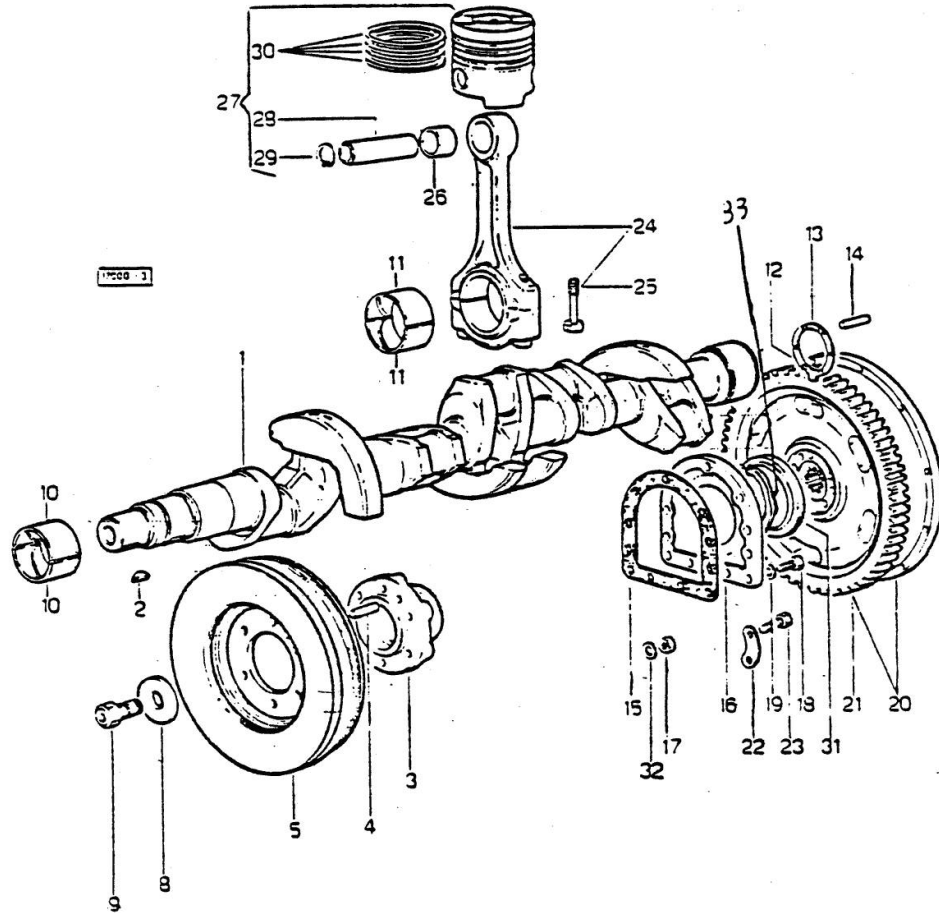

1	0.041.1210.4/10	1	old part number
2	2.1799.002.0	1	stick 10x13
3	0.037.1250.0/10	1	hub
4	2.1651.911.0	1	cylindrical plug
5	0.046.1246.3	1	antivibration pulley
8	0.001.6020.0	1	shoulder
9	2.0129.032.2	1	screw m 24 p.2x45
10	0.073.0059.0	12	main half bushing - mm 1.00
10	0.073.1215.0	12	main half bushing STANDARD
10	0.073.1215.7	12	main half bushing - mm 0.25
10	0.073.1215.8	12	main half bushing - mm 0.50
10	0.073.1215.9	12	main half bushing - mm 0.75
11	0.062.0059.0	10	con.rod half bushing - mm 1.00
11	0.062.1225.0	10	con.rod half bushing STANDARD
11	0.062.1225.7	10	con.rod half bushing - mm 0.25
11	0.062.1225.8	10	con.rod half bushing - mm 0.50
11	0.062.1225.9	10	con.rod half bushing - mm 0.75
12	0.001.4547.0	2	shoulder ring + mm 0.05
12	0.001.4548.0	2	shoulder ring + mm 0.10
12	0.001.4549.0	2	shoulder ring + mm 0.15
12	0.042.1219.0	2	shoulder ring STANDARD
13	0.001.4544.0	2	shoulder ring + mm 0.05
13	0.001.4545.0	2	shoulder ring + mm 0.10
13	0.001.4546.0	2	shoulder ring + mm 0.15
13	0.042.1218.0	2	shoulder ring STANDARD
14	2.1651.915.0	2	pin 12x35
15	0.029.1250.0/10	1	gasket
16	0.029.1240.0	1	flange
			IN TYPES WITHOUT FIG. 33
16	0.029.1240.0/10	1	flange
			IN TYPES WITH FIG. 33 11704 <=>
16	0.045.1240.0	1	flange => 11705
17	2.1011.421.2	1	nut m 10 p.1.25
18	2.0112.309.2	1	screw m 10 p.1.5 x 25
19	2.1474.010.2	2	washer 10
20	0.042.1241.3	1	flywheel
			5000 <=>
20	0.062.1241.3	1	flywheel
			=> 5001
21	0.036.1242.0	1	crown wheel Z = 126, mm 15

Section: ENGINE
CRANKSHAFT

Fig.	P/n	QTY	Name
22	2.1379.006.0	3	lock-tab 15x15x36,5
23	2.0122.517.7	6	screw m 14 p.1.5x45
24	0.039.1220.3/30	5	engine connecting rod
25	0.039.1250.0	10	screw m 14 p.1.5x63
26	2.1559.114.0/10	5	special bushing
27	0.073.0061.6	5	complete piston + mm 0.50
27	0.073.0062.6	5	complete piston + mm 1.0
27	0.073.0066.6	5	ground piston cylinder kit
28	0.038.1236.0/10	5	piston pin Ø 18 / Ø 35 / L = mm 90
29	2.1411.014.1	10	circlip 35
30	0.042.0052.6	5	piston ring set STANDARD
30	0.042.0053.6	5	piston ring set + mm 0.50
30	0.042.0054.6	5	piston ring set + mm 1.0
31	2.1519.009.0/10	1	special oil seal
32	2.1560.006.0	2	gasket 10.2 x 16
33	2.1599.404.0	1	shoulder ring

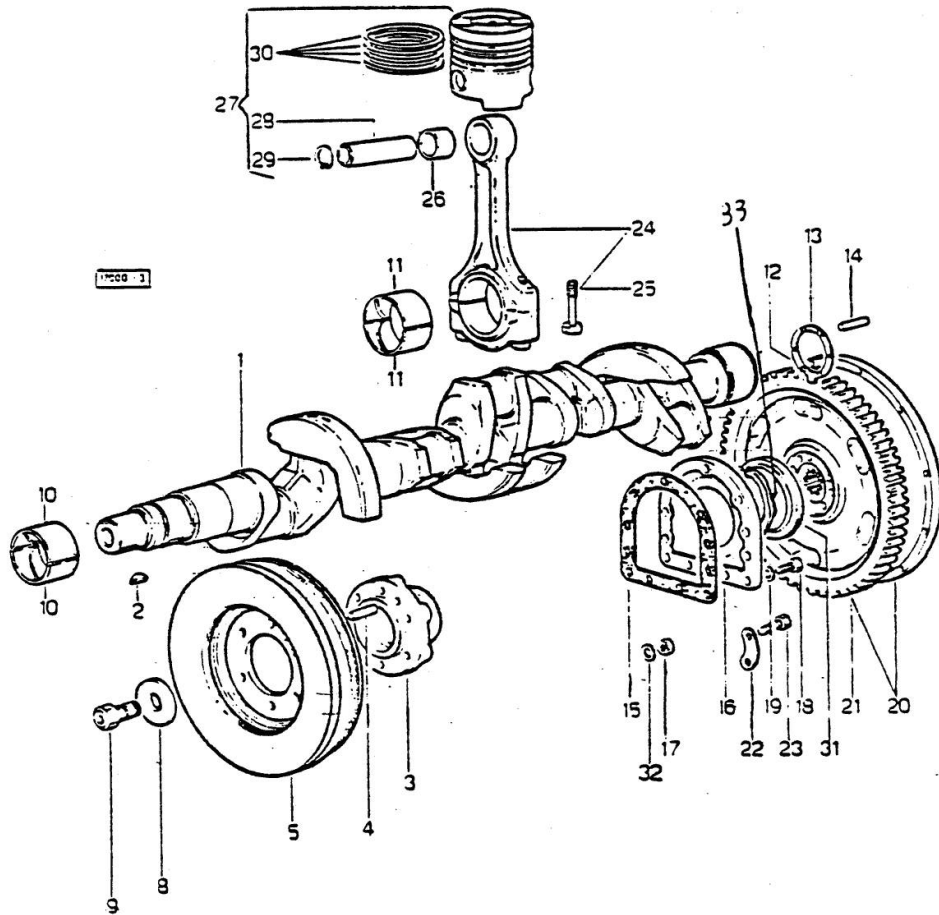

Section: ENGINE

CAMSHAFT

Fig.	P/n	QTY	Name
------	-----	-----	------

Notes:

[JAGUAR 100 EXPORT]

1	0.048.1310.0/20	1	camshaft
2	2.3130.001.1	1	plug 1/8" gas
3	0.027.1314.0/20	1	flange
4	2.1470.004.2	2	lock washer 8
5	2.0112.207.2	2	screw m 8 p 1.25 x 20
6	0.062.1321.0	1	gear z=66
7	2.0139.005.1	4	screw m 10 p.1 x 25
8	0.040.1320.0	1	gear z = 33
9	2.1720.010.0	1	key 5x9
10	0.040.1323.0/10	1	gear Z = 38
11	0.052.1330.0/20	10	tappets
12	0.041.1331.3	10	rod
13	0.041.1332.0	10	sleeve
14	2.1539.020.0	10	special oil seal 13.95x2.62
15	2.1539.022.0	10	special oil seal 12.37x2.62
16	2.4019.162.1/20	10	spring 17.2x46x1.8
17	0.041.1355.3	1	transmission
18	2.1560.014.0	1	washer 18.2 x 24

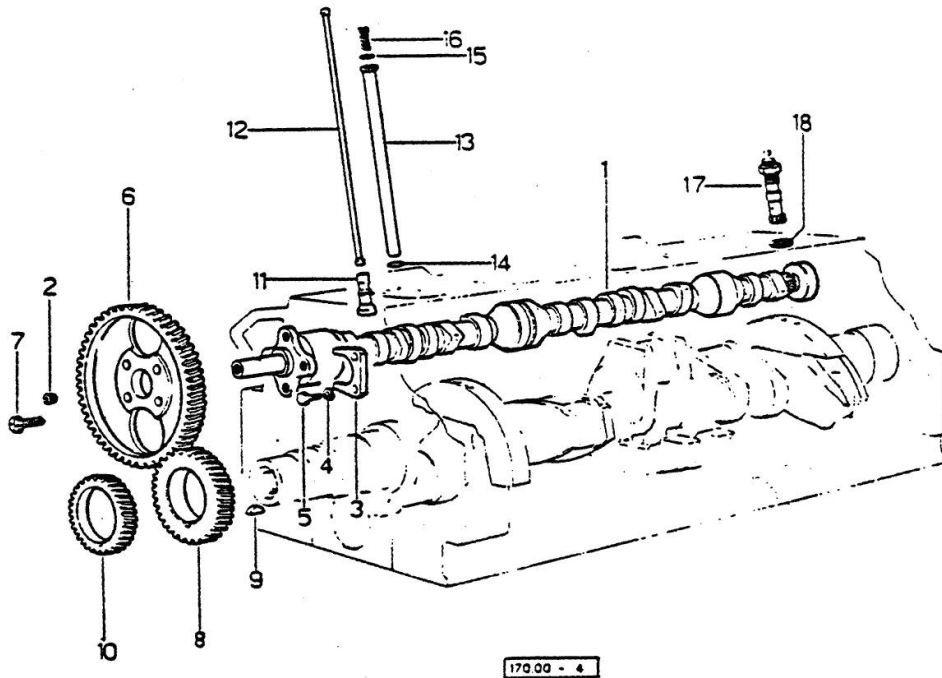

Section: ENGINE
CYLINDER HEAD

Fig.	P/n	QTY	Name
------	-----	-----	------

Notes:
[JAGUAR 100 EXPORT]

0	0.073.0057.6	1	gasket set
1	0.044.1450.3/50	5	engine head 10459 <=
1	0.062.1410.3/10	5	engine head => 10460
2	0.045.1417.0	5	valve guide 10459 <=
2	0.062.1417.0/10	5	valve guide => 10460
3	0.037.1416.0	5	valve guide 10459 <=
3	0.062.1416.0/10	5	valve guide => 10460
4	0.037.1452.0/10	5	valve seat 10459 <=
4	0.062.1450.0/10	5	valve seat => 10460
5	0.037.1451.0/10	5	valve seat 10459 <=
5	0.062.1451.0/10	5	valve seat => 10460
6	2.0439.087.1/20	10	stud bolt m 8 p.1.25 / p.1 x 40
7	2.1569.078.0/10	5	gasket 106x118x0.5
8	2.1019.037.0	7	special nut m 12 p.1.5
9	2.0432.007.2	9	stud bolt m 8 p.1.25 / p.1 x 30
10	2.0432.027.7	5	stud bolt m 8 p.1.25 - 1.00 x 120
11	2.1599.144.7	20	shoulder ring 12.5x23x4
12	2.1019.025.0	13	special nut m 12 p.1.5
13	0.029.1450.0/20	5	tappet gasket
14	0.039.1440.0	5	cap
15	2.1560.004.0	5	copper gasket 8.2 x 14
16	2.1099.056.2	5	special nut m 8 p.1 x 8
17	0.041.1430.0	5	support
18	2.1599.160.0	20	washer 10.5x19x4
19	2.1099.035.0	20	special nut m 10 p.1.25
20	0.029.1452.0	5	tube
21	0.039.1451.0	5	stud bolt
22	2.1011.421.2	5	nut m 10 p.1.25
23	2.1310.006.2	5	flat washer 10.5x21
24	0.002.5937.3/30	5	rocker arm
25	2.1559.021.0/40	5	bushing 15x19x22

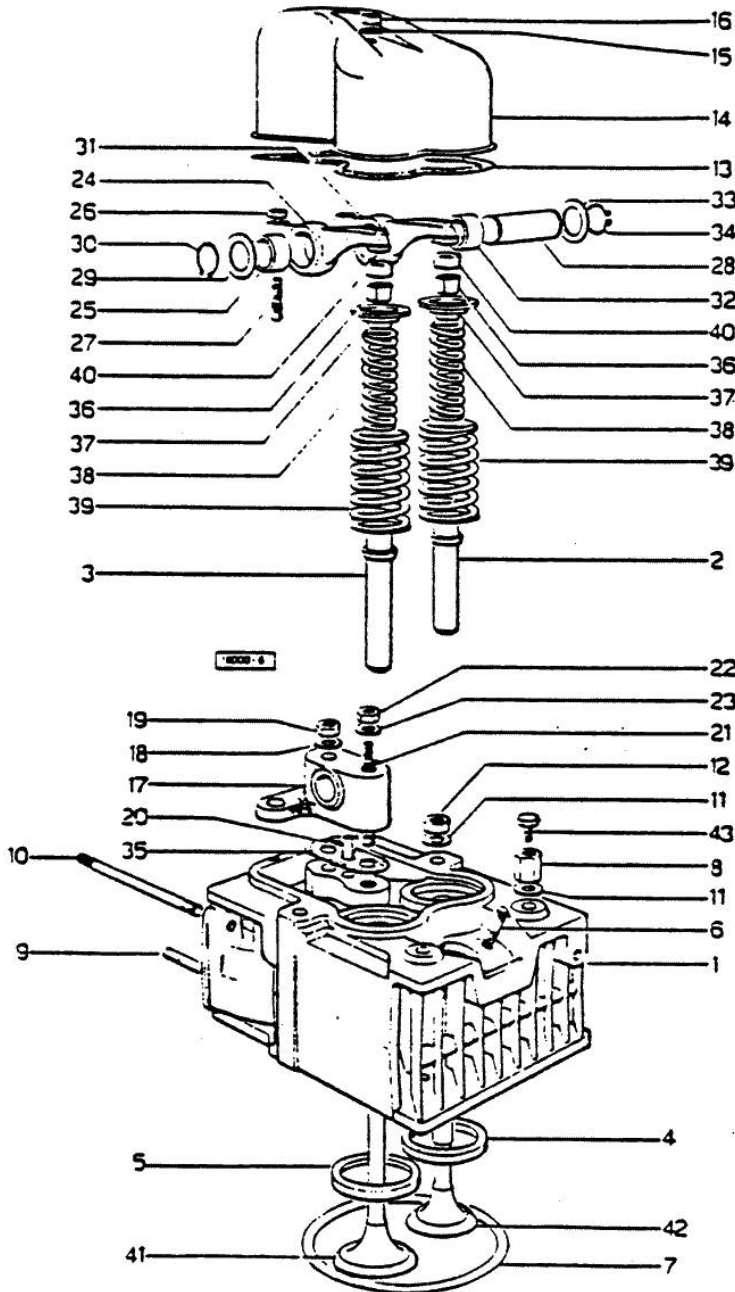

Section: ENGINE
CYLINDER HEAD

Fig.	P/n	QTY	Name
26	2.1011.405.2	10	nut m 8 p.1
27	0.021.1434.0	10	screw
28	0.041.1431.0	5	pin
29	2.1599.019.0	5	shoulder ring 19.5x31x2
30	2.1410.055.7	5	circlip 19
31	0.002.5936.3/40	5	rocker arm
32	2.1559.021.0/40	5	bushing 15x19x22
33	2.1599.019.0	5	shoulder ring 19.5x31x2
34	2.1410.055.7	5	circlip 19
35	0.034.1450.0	5	tappet gasket
36	0.062.1423.0/10	10	conical valve cotter => 10460
36	0.074.1423.0	10	conical valve cotter 10459 <=
37	0.002.9215.0/20	10	cup 10459 <=
37	0.062.1425.0	10	cup => 10460
38	2.4019.194.0	10	spring 22.70x50.7x2.1
39	2.4019.193.0	10	spring 36.15x55.2x3.2
40	0.021.1453.0/20	10	small cover 10459 <=
40	0.062.1452.0	10	small cover => 10460
41	0.042.1420.2	5	inlet valve Ø mm 8 => 10460
41	0.052.1420.0	5	inlet valve Ø mm 9 10459 <=
42	0.039.1421.0	5	exhaust valve Ø mm 9 10459 <=
42	0.071.1420.2	5	exhaust valve Ø mm 8 => 10460
43	2.0119.053.1	3	screw

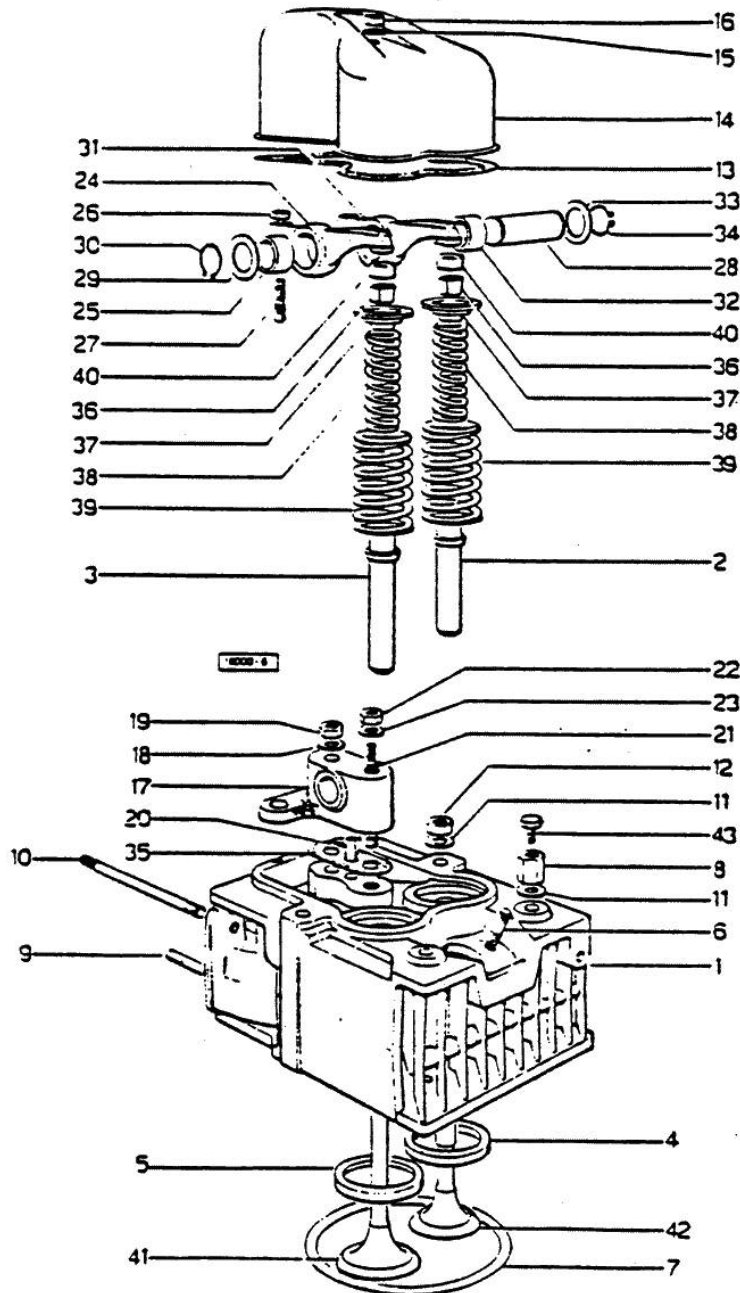



Suggest:

For more complete manuals. Please go to the home page.

<https://www.ebooklibonline.com>

If the above button click is invalid. Please download this document first, and then click the above link to download the complete manual.

Thank you so much for reading

Section: ENGINE
LUBRICATION

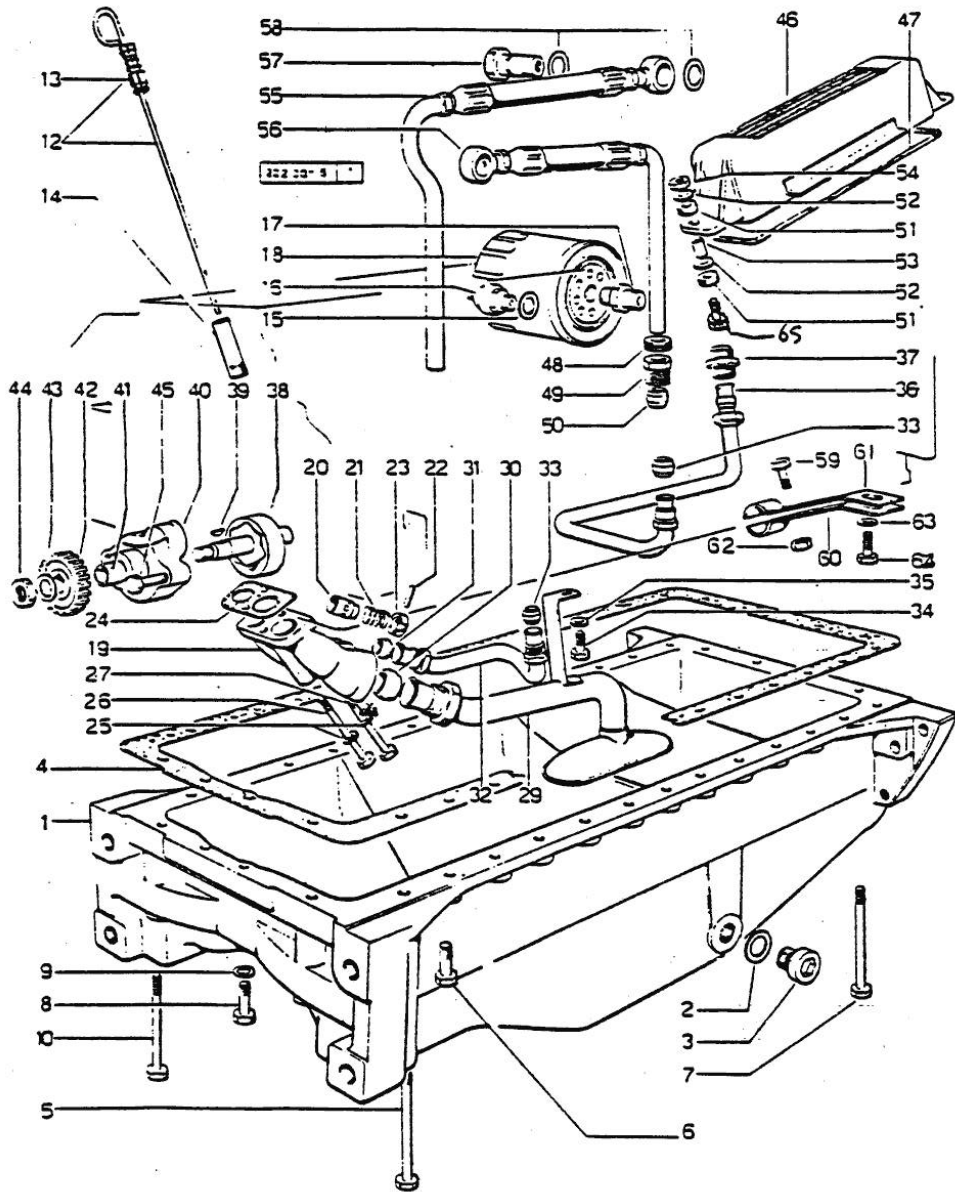

Fig.	P/n	QTY	Name
------	-----	-----	------

Notes:
[JAGUAR 100 EXPORT]

1	0.048.1510.0	1	oil sump
2	2.1560.054.0	1	gasket 21 x 26
3	2.3199.001.2	1	plug 1/2" gas
4	0.041.1512.0	1	gasket
5	2.0112.244.2	2	screw m 8 p.1.25 x 180
6	2.0112.215.2	22	screw m 8 p.1.25 x 40
7	2.0112.237.2	4	screw m 8 p.1.25x140
8	2.0112.217.2	2	screw m 8 p.1.25 x 45
9	2.1560.004.0	4	copper gasket 8.2 x 14
10	2.0112.231.2	2	screw m 8 p.1.25 x 110
12	0.041.1513.3	1	dipstick
13	0.034.1551.0	1	gasket
14	0.044.1555.0	1	spacer
15	2.1560.008.0	1	gasket 12.2 x 18
16	2.7099.460.0	1	pressure switch
17	2.3339.094.1/10	1	pipe fitting m 20 p.1.5-3/4 gas
18	0.041.1556.0	1	oil filter element
19	0.052.1530.0	1	tip => 10460
20	0.040.1550.0	1	small piston 10459 <=
20	0.052.1571.0	1	small piston => 10460
21	2.4019.241.1	1	spring 10459 <=
21	2.4019.270.1	1	spring 9.7x54x2 => 10460
22	2.1630.213.0	1	roll pin 3x32
23	0.040.1551.0	1	stop 10459 <=
23	0.054.1558.0/20	1	stop => 10460
24	0.037.1557.0/20	1	gasket
25	2.1480.014.1	2	washer 8
26	2.0112.225.2	1	screw m 8 p.1.25 x 80
27	2.0112.231.2	1	screw m 8 p.1.25 x 110
29	0.048.1531.3	1	tube
30	2.3359.017.1	1	nosepiece
31	2.3359.016.1	1	nosepiece
32	0.044.1560.2	1	tube
33	2.3359.015.1	2	nosepiece

Section: ENGINE
LUBRICATION

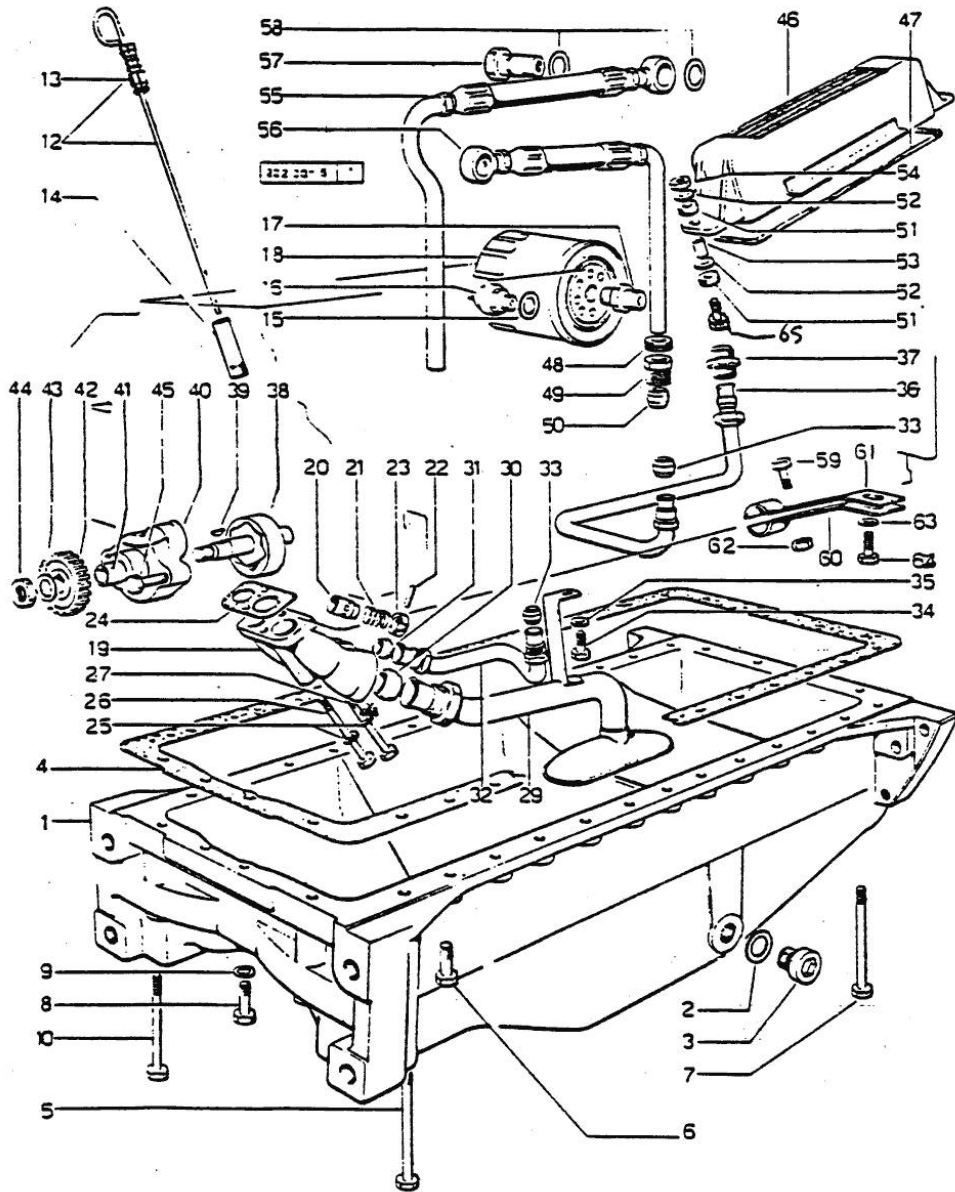

Fig.	P/n	QTY	Name
34	2.0112.204.2	1	screw m 8 p.1.25x14
35	2.1310.004.2	1	flat washer 8.4x17
36	0.048.1543.2/30	1	tube
37	2.3339.159.1/10	1	pipe fitting
38	0.040.1524.6	1	oil pump
39	2.1720.005.0	1	key 4x5
40	0.040.1524.6	1	oil pump
41	2.1559.086.0/10	1	bush
42	0.040.1521.0/10	1	gear z = 27
43	2.1310.007.2	1	flat washer 13 x 24
44	2.1121.109.2	1	self-locking nut m 12 p.1.25
45	2.0112.219.2	2	screw m 8 p.1.25x55
46	0.072.1540.2	1	oil cooler
47	0.047.1552.0	1	gasket
48	2.6560.013.0	2	wire guide 18x1.5
49	2.3339.167.2	2	pipe fitting
50	2.3359.012.0	2	nosepiece 10x16.8
51	0.021.1560.0	4	rubber plug
52	2.1599.006.2	4	shoulder ring 8.4x25x2
53	2.1579.159.2	2	spacer 8.8x12x16
54	2.1011.105.2	2	nut m 8 p.1.25
55	0.047.1550.2/30	1	tube
56	0.047.1551.2/30	1	tube
57	2.3339.107.1	2	pipe union m 22
58	2.1560.018.0	4	gasket 22.2 x 29
59	2.0112.207.2	1	screw m 8 p 1.25 x 20
60	0.046.1550.0	1	bracket
61	0.046.1551.0	1	bracket
62	2.1011.105.2	1	nut m 8 p.1.25
63	2.1310.004.2	1	flat washer 8.4x17
64	2.0112.207.2	1	screw m 8 p 1.25 x 20
65	2.0122.213.2	2	screw m 8 p.1x35

<https://www.ebooklibonline.com>

Hello dear friend!

Thank you very much for reading.

Enter the link into your browser.

The full manual is available for immediate download.

<https://www.ebooklibonline.com>