

Section: ENGINE

CRANKCASE

| Fig. | P/n | QTY | Name |
|------|-----|-----|------|
|------|-----|-----|------|

Notes:

[FOX 45_I]

| | | | |
|----|-----------------|----|------------------------------------|
| 0 | 0.035.0050.6/10 | 1 | gasket set FOR ENGINE ASSEMBLY |
| 1 | 0.035.1110.4/40 | 1 | crankcase |
| 2 | 0.004.8776.0 | 1 | support |
| 3 | 0.029.1113.0 | 2 | support |
| 5 | 0.029.1116.0 | 1 | support |
| 6 | 0.021.1157.0 | 4 | stud bolt |
| 7 | 0.029.1117.0 | 4 | stud bolt |
| 8 | 2.1599.144.7 | 8 | shoulder ring 12.5x23x4 |
| 9 | 2.1019.026.1 | 8 | special nut m 12 p.1.5 |
| 10 | 0.029.1154.0 | 4 | gasket |
| 11 | 2.1699.116.0 | 1 | pin |
| 12 | 2.0432.018.1 | 5 | stud bolt m 8 p.1.25 / p.1 x 65 |
| 14 | 2.1652.911.0 | 2 | cylindrical plug 12x25 |
| 15 | 2.1653.708.0 | 2 | pin 8x18 |
| 16 | 2.3130.002.1 | 2 | plug 1/4" gas |
| 17 | 2.3139.001.1 | 3 | plug |
| 18 | 2.3130.001.1 | 3 | plug 1/8" gas |
| 19 | 2.1699.021.0 | 1 | pin 7.8x8x20 |
| 20 | 2.3170.022.1 | 1 | expansion plug 60 |
| 21 | 0.029.1155.2/20 | 1 | plate |
| 22 | 2.1470.002.2 | 2 | lock washer 6 |
| 23 | 2.0112.002.2 | 2 | screw m 6 p.1 x 10 |
| 30 | 0.029.1130.0/20 | 1 | flange |
| 32 | 2.0112.511.1 | 11 | screw m 14 p.2 x 30 |
| 33 | 2.0432.267.1 | 2 | stud bolt m 12 p.1.75-1.25x60 |
| 34 | 2.1011.207.2 | 2 | nut m 12 p.1.5 |
| 35 | 2.1589.036.0 | 3 | shim |
| 36 | 2.1589.037.0 | 3 | shim |
| 37 | 0.039.1122.0 | 12 | stud bolt m 12 p.1.5x310 |
| 38 | 0.037.1122.0 | 3 | stud bolt |
| 39 | 0.036.1120.0/10 | 3 | engine cylinder |
| 40 | 2.1569.055.0 | 3 | shim |
| 41 | 2.1653.708.0 | 1 | pin 8x18 |
| 42 | 2.0432.267.1 | 2 | stud bolt m 12 p.1.75-1.25x60 |
| 43 | 2.0432.153.1 | 2 | stud bolt m 10 p.1.5 / p.1.25 x 20 |
| 44 | 2.1474.010.1 | 2 | spring washer 10 |
| 45 | 2.1011.421.2 | 2 | nut m 10 p.1.25 |

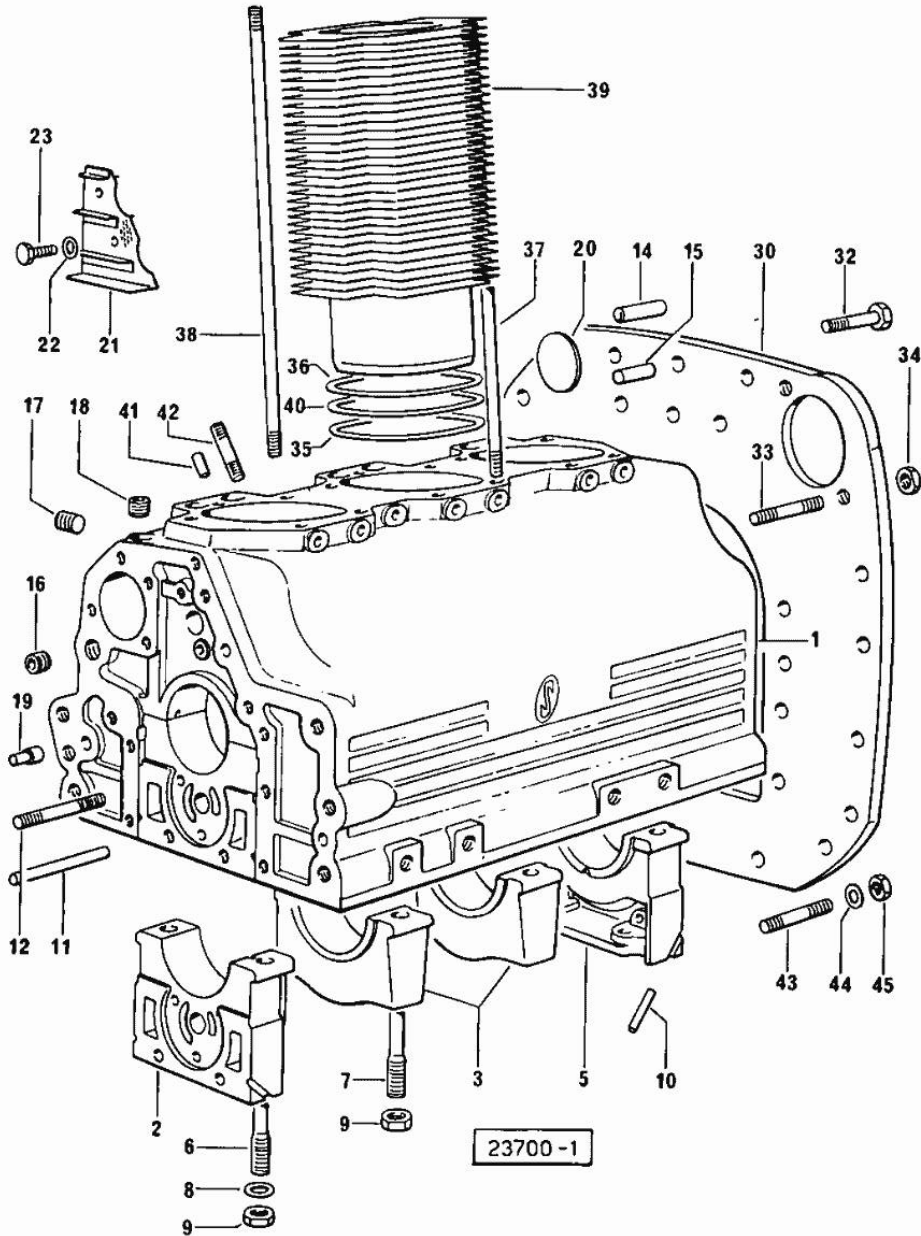

Section: ENGINE
TIMING CASE

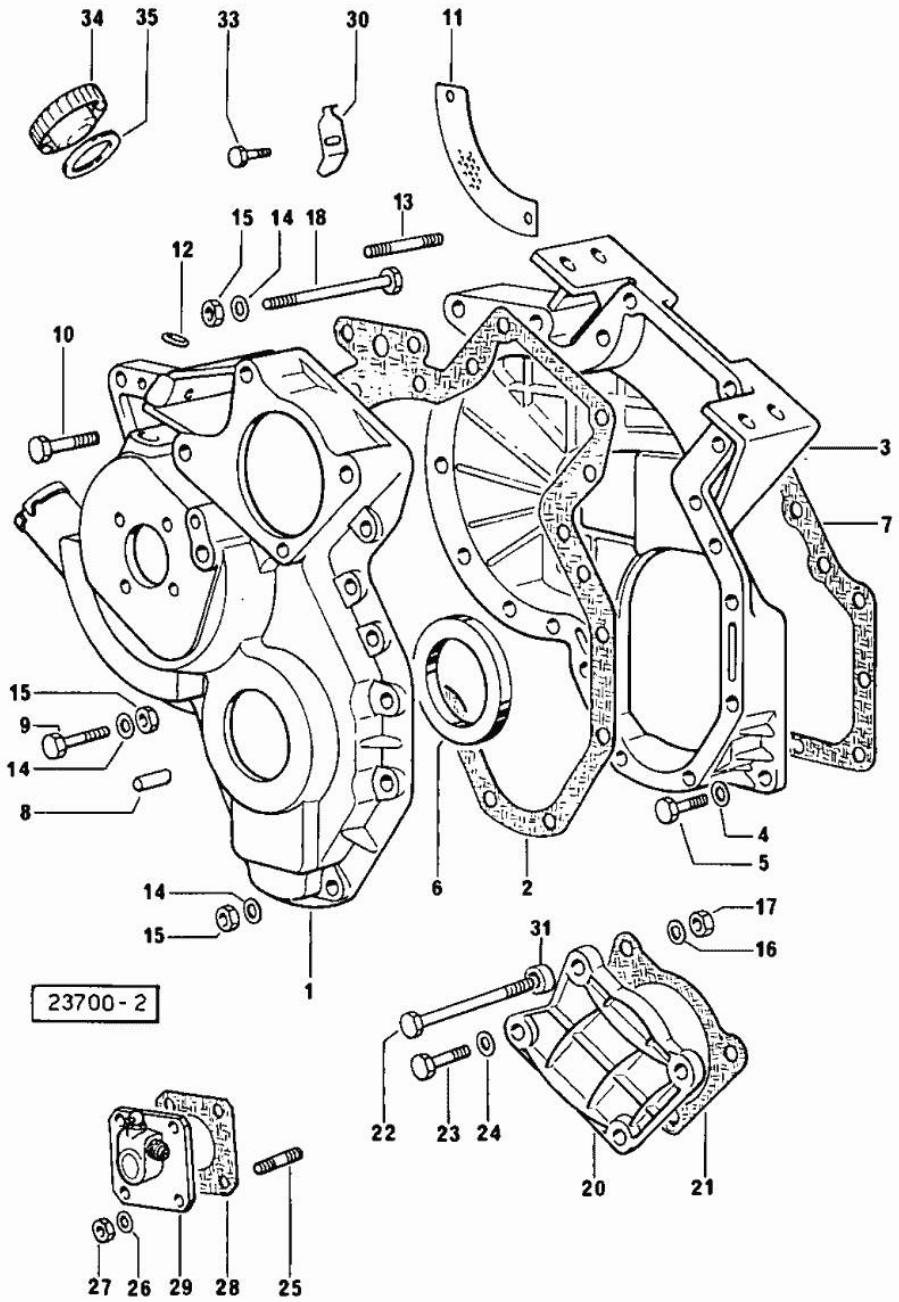

| Fig. | P/n | QTY | Name |
|------|-----|-----|------|
|------|-----|-----|------|

Notes:
[FOX 45_I]

| | | | |
|----|-----------------|----|---------------------------|
| 1 | 0.320.1554.0 | 1 | governor housing |
| 2 | 0.027.1156.0 | 1 | gasket |
| 3 | 0.027.1154.0/30 | 1 | flange |
| 4 | 2.1474.009.1 | 8 | spring washer 8 |
| 5 | 2.0112.207.2 | 8 | screw m 8 p.1.25 x 20 |
| 6 | 2.1519.010.0 | 1 | special oil seal 58x80x10 |
| 7 | 0.029.1153.0/10 | 1 | gasket |
| 8 | 2.1652.711.0 | 1 | cylindrical plug 8x25 |
| 9 | 2.0122.213.2 | 4 | screw m 8 p.1x35 |
| 10 | 2.0122.222.2 | 1 | screw |
| 11 | 0.027.1152.0/20 | 1 | small plate |
| 12 | 2.1530.028.0 | 1 | oil seal 11.91 x 2.62 |
| 13 | 2.0439.060.2 | 3 | stud bolt m 8 p.1.25-1x22 |
| 14 | 2.1474.009.1 | 15 | spring washer 8 |
| 15 | 2.1011.405.2 | 15 | nut m 8 p.1 |
| 16 | 2.1474.009.1 | 2 | spring washer 8 |
| 17 | 2.1011.405.2 | 3 | nut m 8 p.1 |
| 18 | 2.0122.225.2 | 2 | screw m 8 p.1x80 |
| 20 | 0.029.1163.0 | 1 | small cover |
| 21 | 0.054.1155.0 | 1 | gasket |
| 22 | 2.0122.233.2 | 2 | screw |
| 23 | 2.0112.211.2 | 2 | screw m 8 p.1.25 x 30 |
| 24 | 2.1474.009.1 | 2 | spring washer 8 |
| 25 | 2.0439.055.1 | 4 | stud bolt m 6 p.1 x 18 |
| 26 | 2.1470.002.2 | 4 | lock washer 6 |
| 27 | 2.1011.103.2 | 4 | nut m 6 p.1 |
| 28 | 0.026.1150.0 | 1 | gasket |
| 29 | 2.7049.210.0/20 | 1 | transmission |
| 30 | 0.027.1150.0/10 | 1 | index |
| 31 | 2.1579.191.0 | 1 | spacer 8.5 x 18 x 20 |
| 33 | 2.0112.204.2 | 1 | screw m 8 p.1.25x14 |
| 34 | 2.3199.535.0 | 1 | plug |
| 35 | 2.1530.014.0 | 1 | oil seal |

Section: ENGINE

CRANKSHAFT

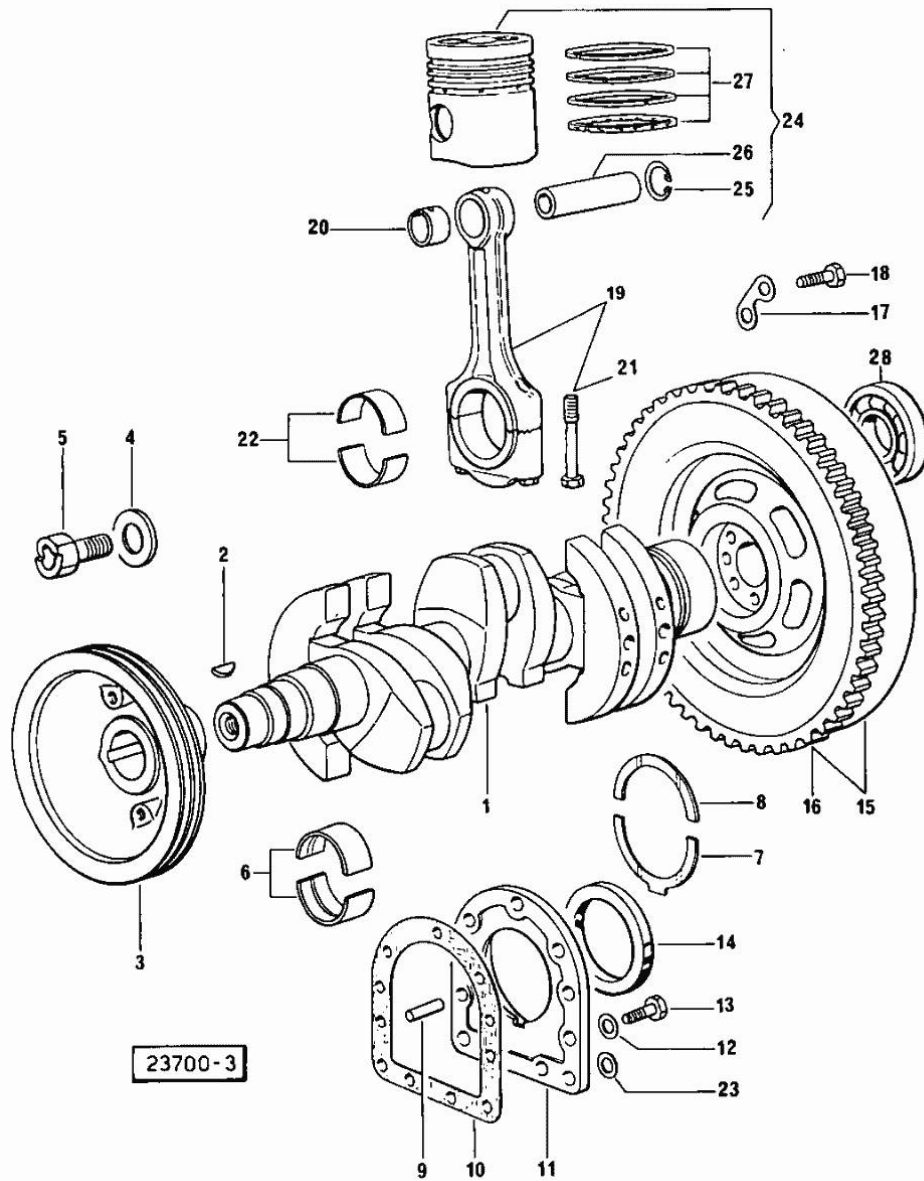

| Fig. | P/n | QTY | Name |
|------|-----|-----|------|
|------|-----|-----|------|

Notes:
[FOX 45_I]

| | | | |
|----|-----------------|---|---------------------------------|
| 1 | 0.029.1210.4/30 | 1 | crankshaft |
| 2 | 2.1799.002.0 | 1 | stick 10x13 |
| 3 | 0.035.1244.0/20 | 1 | pulley |
| 4 | 0.001.6020.0 | 1 | shoulder |
| 5 | 2.0129.032.2 | 1 | screw m 24 p.2x45 |
| 6 | 0.029.0066.0 | | main half bushing - mm 1.00 |
| 6 | 0.029.1215.0/10 | 8 | main half bushing |
| 6 | 0.029.1215.7 | | main half bushing - mm 0.25 |
| 6 | 0.029.1215.8 | | main half bushing - mm 0.50 |
| 6 | 0.029.1215.9 | | main half bushing - mm 0.75 |
| 7 | 0.001.4547.0 | | shoulder ring + mm 0.05 |
| 7 | 0.001.4548.0 | | shoulder ring + mm 0.10 |
| 7 | 0.001.4549.0 | | shoulder ring + mm 0.15 |
| 7 | 0.042.1219.0 | 2 | shoulder ring STANDARD |
| 8 | 0.001.4544.0 | | shoulder ring + mm 0.05 |
| 8 | 0.001.4545.0 | | shoulder ring + mm 0.10 |
| 8 | 0.001.4546.0 | | shoulder ring + mm 0.15 |
| 8 | 0.042.1218.0 | 2 | shoulder ring STANDARD |
| 9 | 2.1652.915.0 | 2 | cylindrical plug 12x35 |
| 10 | 0.029.1250.0 | 1 | gasket |
| 11 | 0.045.1240.0 | 1 | flange |
| 12 | 2.1474.010.1 | 6 | spring washer 10 |
| 13 | 2.0112.309.2 | 7 | screw m 10 p.1.5 x 25 |
| 14 | 2.1519.009.0 | 1 | special oil seal |
| 15 | 0.035.1264.3 | 1 | flywheel |
| 16 | 0.038.1242.0 | 1 | crown wheel Z = 120, mm 15 |
| 17 | 2.1379.006.0 | 3 | lock-tab 15x15x36,5 |
| 18 | 2.0122.515.1 | 6 | screw |
| 19 | 0.039.1220.3/20 | 3 | engine connecting rod |
| 20 | 2.1559.114.0 | 1 | bushing |
| 21 | 0.039.1250.0 | 6 | screw m 14 p.1.5x63 |
| 22 | 0.039.0068.0 | | con.rod half bushing - mm 1.016 |
| 22 | 0.039.1225.0 | 6 | con.rod half bushing |
| 22 | 0.039.1225.7 | | con.rod half bushing -mm 0.254 |
| 22 | 0.039.1225.8 | | con.rod half bushing -mm 0.508 |
| 22 | 0.039.1225.9 | | con.rod half bushing -mm 0.762 |
| 23 | 2.1480.015.1 | 2 | washer 10 |
| 24 | 0.036.0060.6 | 3 | complete piston |
| 24 | 0.036.0061.6 | | complete piston + mm 0.5 |
| 24 | 0.036.0062.6 | | complete piston + mm 1.00 |
| 25 | 2.1411.014.1 | 6 | circlip 35 |

<https://www.ebooklibonline.com>

Hello dear friend!

Thank you very much for reading.

Enter the link into your browser.

The full manual is available for immediate download.

<https://www.ebooklibonline.com>

Section: ENGINE
CRANKSHAFT

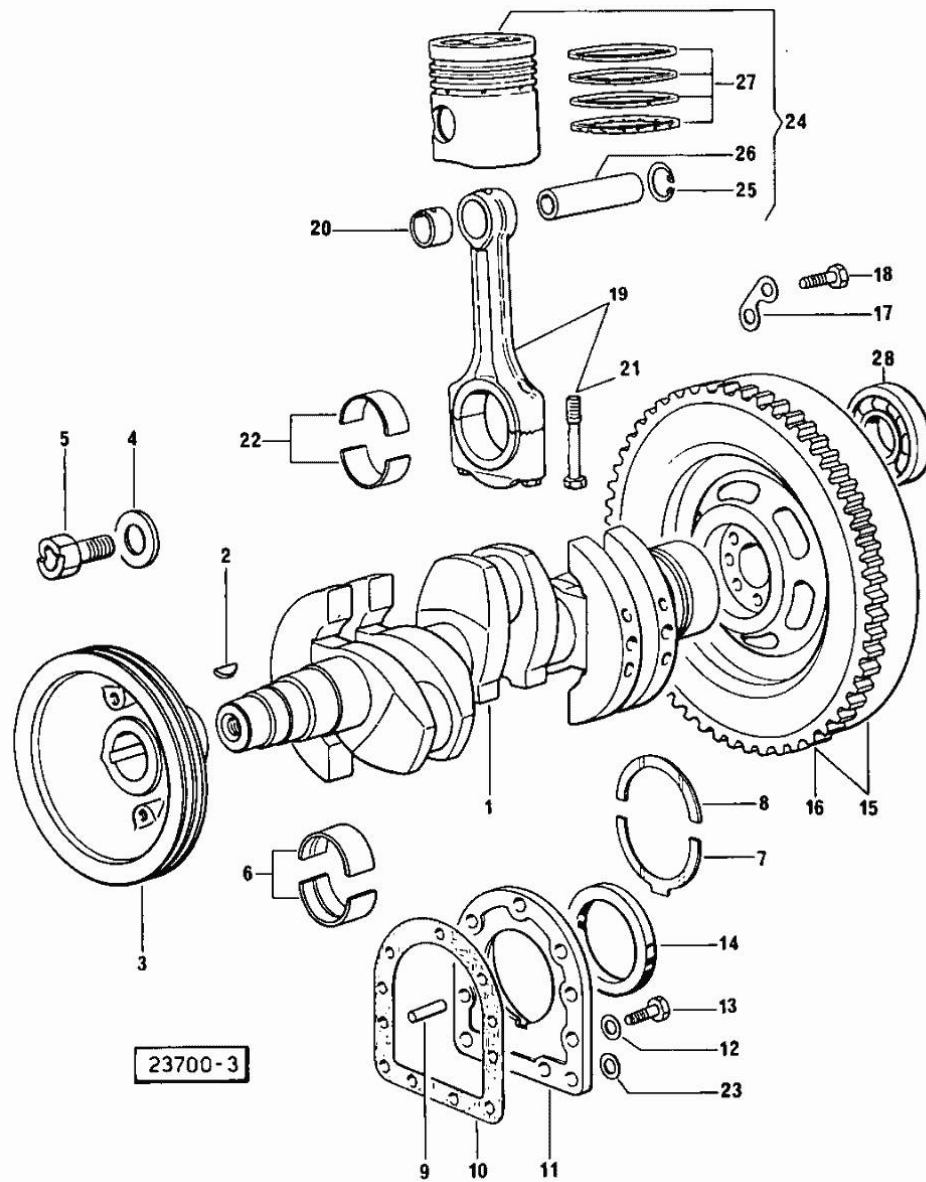

| Fig. | P/n | QTY | Name |
|------|--------------|-----|---------------------------|
| 26 | 0.002.4167.0 | 3 | piston pin |
| 27 | 0.034.0052.6 | 3 | piston ring set |
| 27 | 0.034.0053.6 | | piston ring set + mm 0.5 |
| 27 | 0.034.0054.6 | | piston ring set + mm 1.0 |
| 28 | 2.2061.005.0 | 1 | ball bearing iso 17 bc 03 |

Section: ENGINE

CAMSHAFT

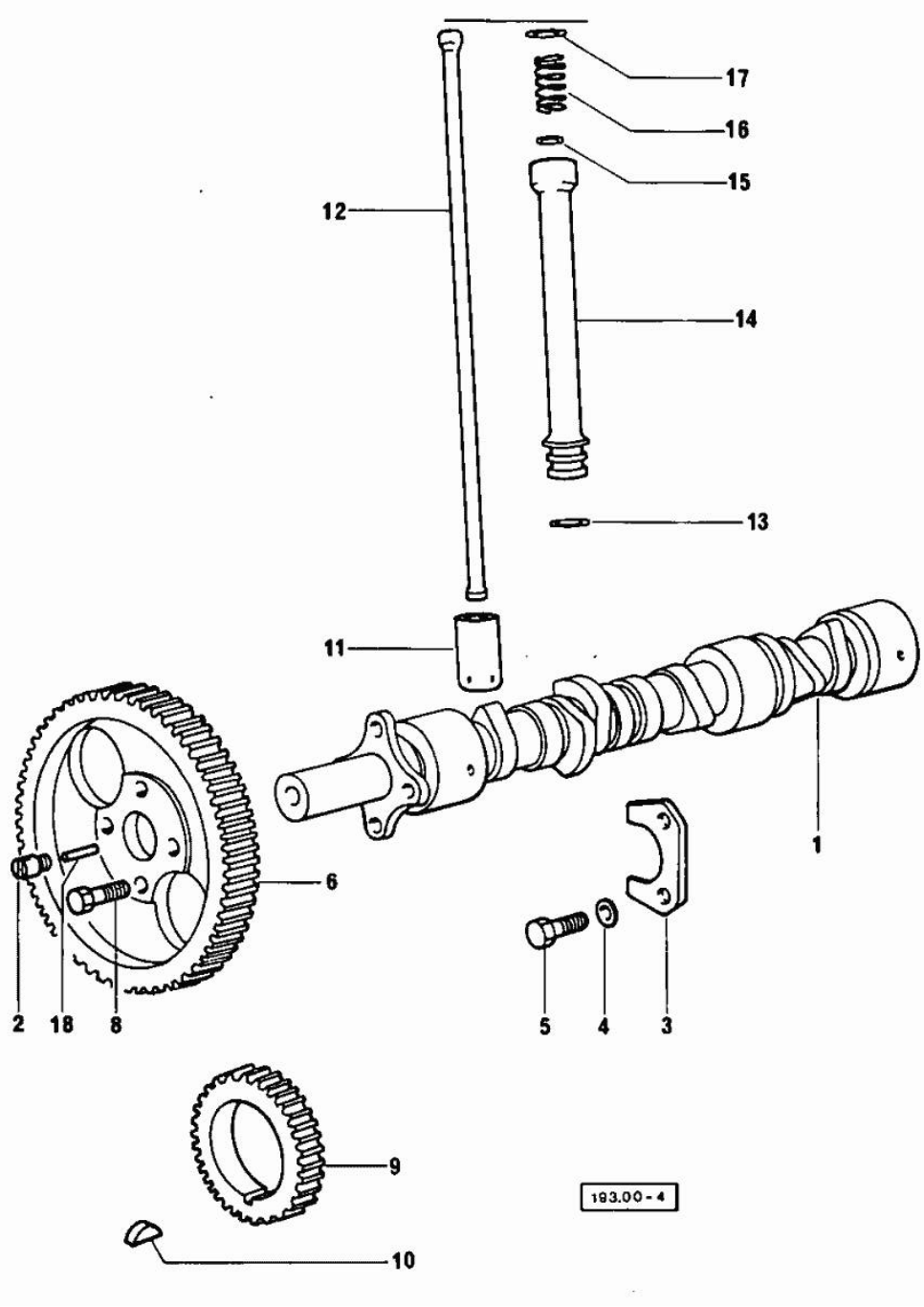

| Fig. | P/n | QTY | Name |
|------|-----|-----|------|
|------|-----|-----|------|

Notes:
[FOX 45_I]

| | | | |
|----|-----------------|---|-----------------------------|
| 1 | 0.035.1310.0/10 | 1 | camshaft |
| 2 | 0.027.1350.0/20 | 1 | pin |
| 3 | 0.027.1314.0 | 1 | flange |
| 4 | 2.1470.004.2 | 2 | lock washer 8 |
| 5 | 2.0312.206.2 | 2 | screw m 8 p 1.25 x 20 |
| 6 | 0.035.1321.0 | 1 | gear |
| 8 | 2.0139.006.1 | 4 | screw |
| 9 | 0.029.1320.0/10 | 1 | gear wheel |
| 10 | 2.1720.010.0 | 1 | key 5x9 |
| 11 | 0.002.3909.0 | 6 | tappets |
| 12 | 0.037.1331.0 | 6 | rod |
| 13 | 2.1539.018.0 | 6 | special oil seal |
| 14 | 0.039.1332.0/10 | 6 | sleeve |
| 15 | 2.1539.022.0 | 6 | special oil seal 12.37x2.62 |
| 16 | 2.4019.149.1 | 6 | spring 14x29x2 |
| 17 | 2.1569.037.0 | 6 | gasket |
| 18 | 2.1650.513.0 | 1 | pin 6 x 30 |

Section: ENGINE
CYLINDER HEAD

| Fig. | P/n | QTY | Name |
|------|-----|-----|------|
|------|-----|-----|------|

 Notes:
 [FOX 45_I]

| | | | |
|----|-----------------|----|--|
| 0 | 0.034.0057.6 | 1 | gasket set FOR GRINDING VALVES OF ONE CYLINDER AND PISTON RING RENEWAL |
| 1 | 0.037.1450.3/30 | 3 | engine head |
| 2 | 0.037.1416.0 | 3 | valve guide |
| 3 | 0.037.1417.0/10 | 3 | valve guide |
| 4 | 0.037.1451.0/10 | 3 | valve seat |
| 5 | 0.037.1452.0/10 | 3 | valve seat |
| 6 | 2.0432.001.1 | 6 | stud bolt m 14 p.2-1.5x35 |
| 6 | 2.0432.011.1 | 6 | stud bolt m 8 p.1.25 / p.1 x 40 |
| 7 | 0.029.1418.0 | 6 | sleeve |
| 8 | 2.1569.056.0/10 | 3 | gasket |
| 9 | 2.0439.081.1 | 6 | stud bolt m 8 x 14 |
| 10 | 2.1599.406.0 | 12 | shoulder ring |
| 11 | 2.1019.005.0 | 7 | old part number |
| 12 | 2.1019.037.0 | 5 | special nut m 12 p.1.5 |
| 13 | 0.029.1450.0 | 3 | gasket |
| 14 | 0.039.1440.0 | 3 | cap |
| 15 | 2.1560.004.0 | 3 | copper gasket 8.2 x 14 |
| 16 | 2.1099.056.1 | 3 | special nut m8 p.1 |
| 17 | 0.034.1430.0 | 3 | support |
| 18 | 0.029.1452.0 | 3 | tube |
| 19 | 0.034.1450.0 | 3 | tappet gasket |
| 20 | 002.5937.3/30 | 3 | rocker arm |
| 21 | 2.1559.021.0/40 | 3 | bushing 15x19x22 |
| 22 | 0.002.5936.3/40 | 3 | rocker arm |
| 23 | 2.1559.021.0/40 | 3 | bushing 15x19x22 |
| 24 | 0.029.1431.0 | 3 | pin |
| 25 | 2.0512.102.1 | 3 | screw m 6 p.1 x 8 |
| 26 | 2.1599.019.0 | 6 | shoulder ring 19.5x31x2 |
| 27 | 2.1410.055.1 | 6 | circlip 19 |
| 28 | 0.021.1434.0 | 6 | screw |
| 29 | 2.1011.405.2 | 6 | nut m 8 p.1 |
| 30 | 0.039.1451.0 | 3 | stud bolt |
| 31 | 0.039.1421.0 | 3 | exhaust valve Ø mm 9 |
| 32 | 0.039.1420.0 | 3 | inlet valve |
| 33 | 2.4019.193.0 | 6 | spring 36.15x55.2x3.2 |
| 34 | 2.4019.194.0 | 6 | spring 22.70x50.7x2.1 |
| 35 | 0.002.9215.0/10 | 6 | cup |
| 36 | 0.002.9193.0/10 | 6 | conical valve cotter |
| 37 | 0.021.1453.0/20 | 6 | small cover |

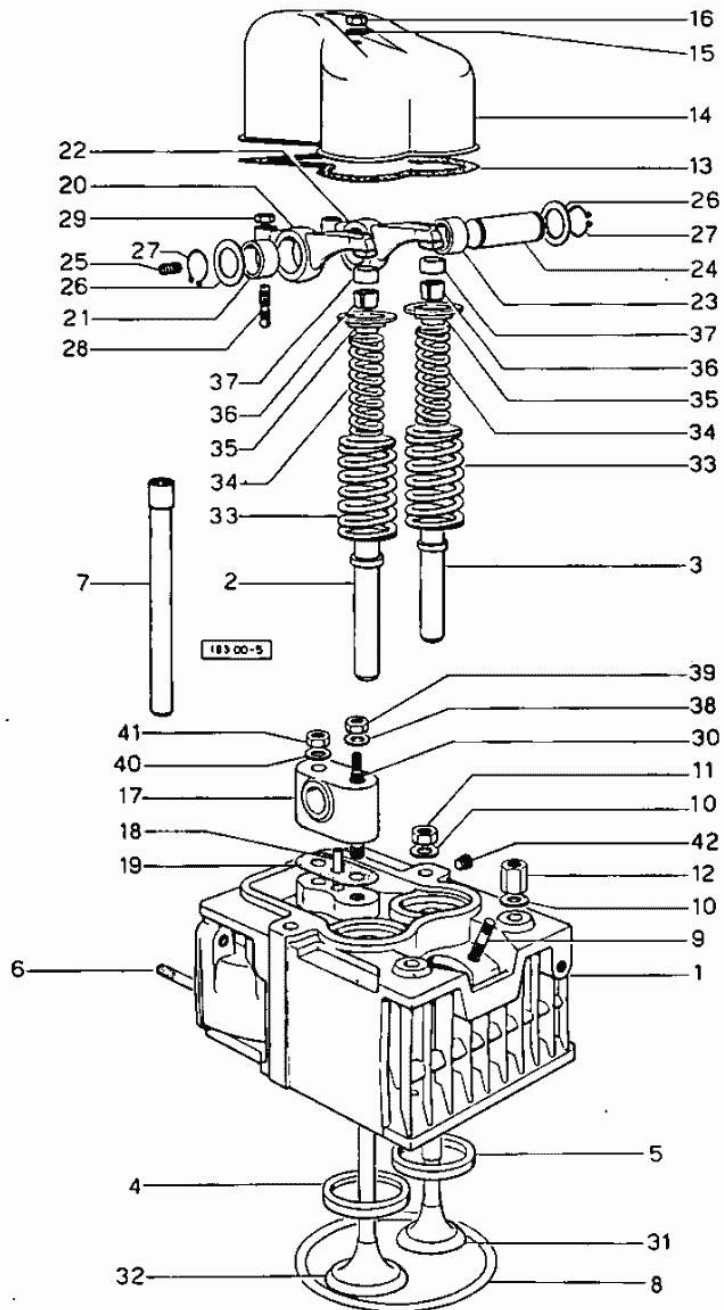

Section: ENGINE
CYLINDER HEAD

| Fig. | P/n | QTY | Name |
|------|--------------|-----|-------------------------|
| 38 | 2.1310.006.2 | 3 | flat washer 10.5x21 |
| 39 | 2.1011.421.2 | 3 | nut m 10 p.1.25 |
| 40 | 2.1599.160.0 | 3 | washer 10.5x19x4 |
| 41 | 2.1099.035.0 | 3 | special nut m 10 p.1.25 |
| 42 | 2.3130.001.1 | 3 | plug 1/8" gas |

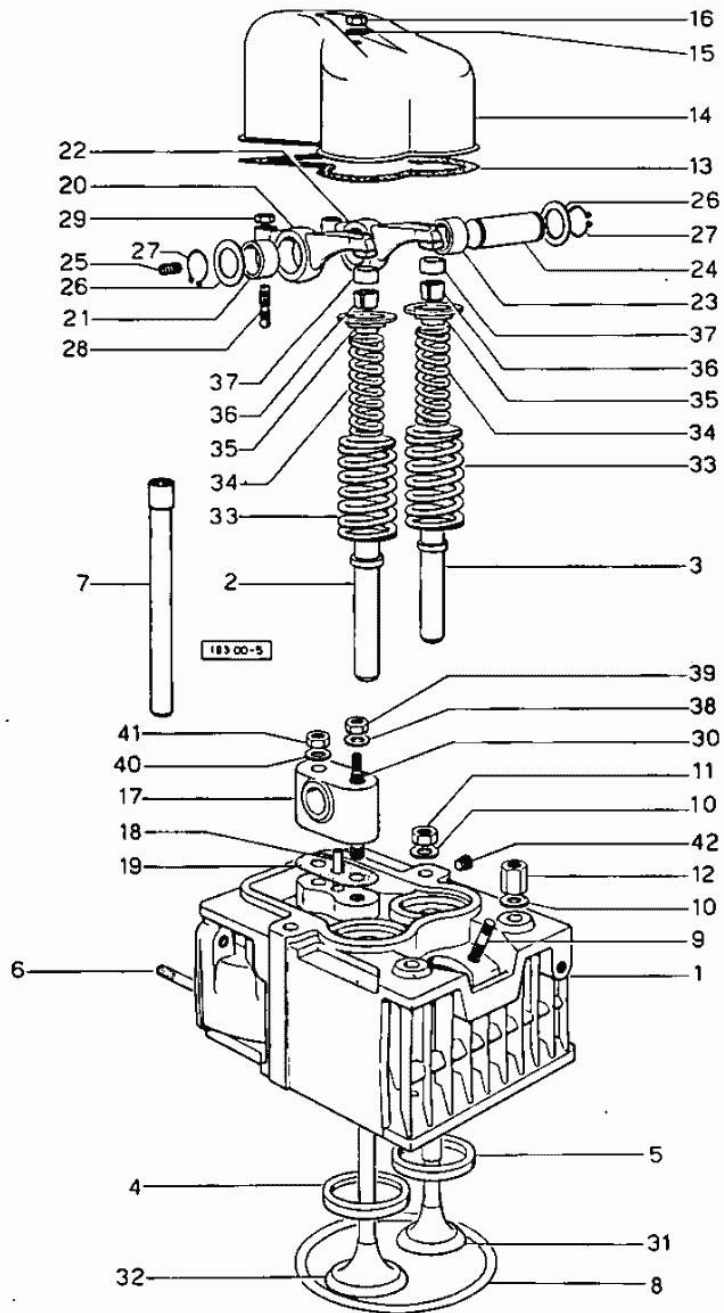

Section: ENGINE
LUBRICATION

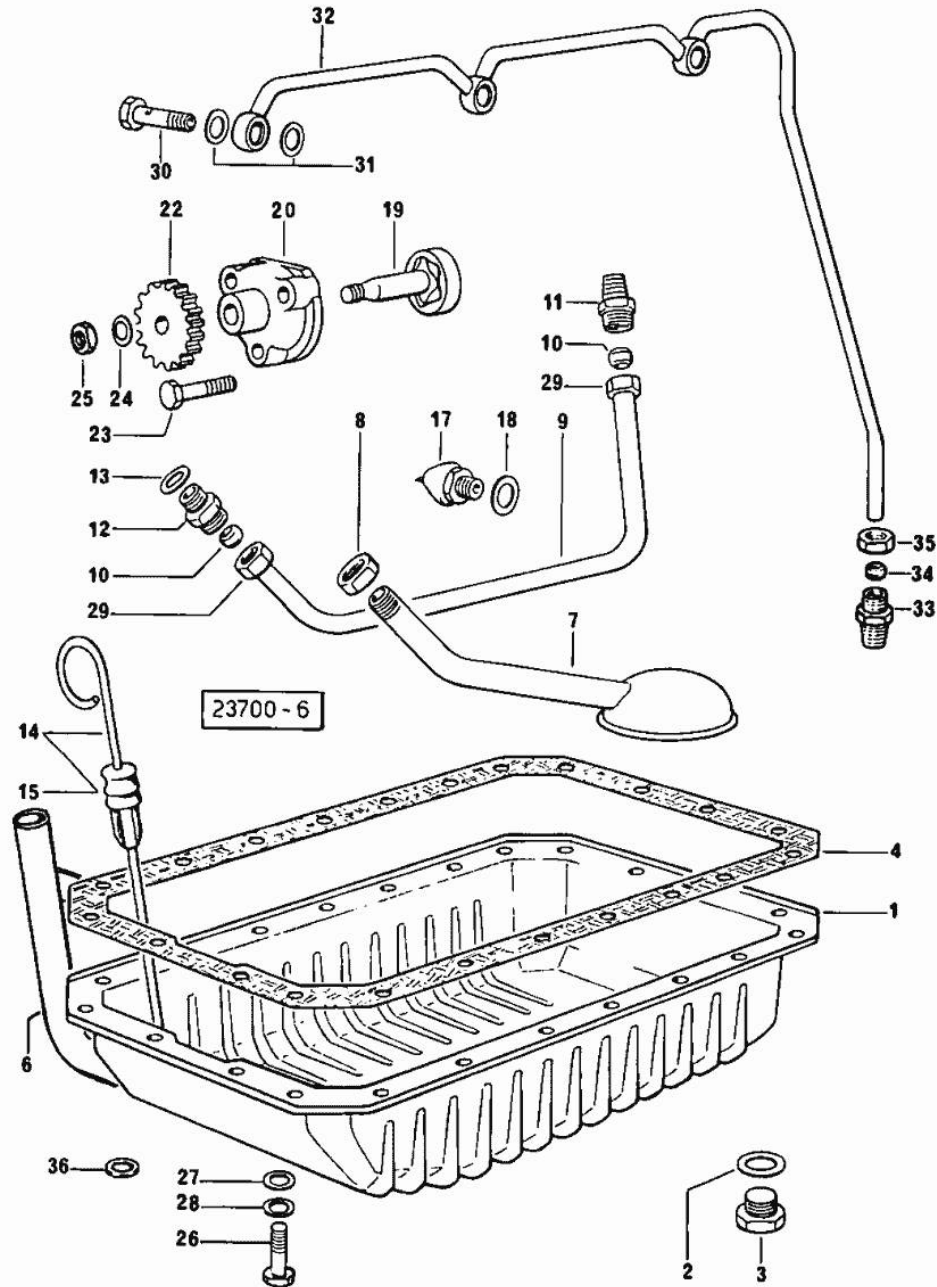

| Fig. | P/n | QTY | Name |
|------|-----|-----|------|
|------|-----|-----|------|

Notes:
[FOX 45_I]

| | | | |
|----|-----------------|----|------------------------------|
| 1 | 0.035.1554.0 | 1 | oil sump |
| 2 | 2.1560.054.0 | 1 | gasket 21 x 26 |
| 3 | 2.3199.001.2 | 1 | plug 1/2" gas |
| 4 | 0.038.1555.0 | 1 | gasket |
| 6 | 0.035.1559.3 | 1 | tube |
| 6 | 2.1310.009.2 | 1 | flat washer 15x20 |
| 7 | 0.035.1555.3 | 1 | tube |
| 8 | 2.1099.026.1 | 1 | special nut |
| 9 | 0.035.1558.0 | 1 | tube |
| 10 | 2.3359.004.2 | 2 | ring |
| 11 | 2.3319.014.1 | 1 | pipe union |
| 12 | 2.3319.013.1 | 1 | pipe union |
| 13 | 2.1560.013.0 | 1 | gasket 18.2x22 |
| 14 | 0.035.1557.3 | 1 | dipstick |
| 15 | 0.034.1551.0 | 1 | gasket |
| 17 | 2.7099.040.0/10 | 1 | pressure switch |
| 18 | 2.1560.008.0 | 1 | gasket 12.2 x 18 |
| 19 | 0.029.1522.3/10 | 1 | shaft |
| 20 | 0.029.1520.0 | 1 | pump casing |
| 22 | 0.029.1521.0/10 | 1 | gear |
| 23 | 2.0112.215.2 | 3 | screw m 8 p.1.25 x 40 |
| 24 | 2.1310.006.2 | 1 | flat washer 10.5x21 |
| 25 | 2.1120.107.2 | 1 | self-locking nut m 12 p.1.75 |
| 26 | 2.0112.209.2 | 14 | screw m 8 p 1.25 x 25 |
| 26 | 2.0112.219.2 | 10 | screw m 8 p.1.25x55 |
| 27 | 2.1470.004.2 | 20 | lock washer 8 |
| 28 | 2.1560.004.0 | 4 | copper gasket 8.2 x 14 |
| 29 | 2.3369.015.1 | 2 | special nut |
| 30 | 2.3339.001.0 | 3 | pipe fitting m 10 p.1 |
| 31 | 2.1560.006.0 | 6 | gasket 10.2 x 16 |
| 32 | 0.038.1536.3/10 | 1 | tube |
| 33 | 2.3319.002.1 | 1 | pipe fitting |
| 34 | 2.3350.002.1 | 1 | nosepiece 6, d128 |
| 35 | 2.3360.002.1 | 1 | union nut m 10 |
| 36 | 2.1530.016.0 | 1 | oil seal 8.73 x 1.78 |

Section: ENGINE
LUBRICATION

| Fig. | P/n | QTY | Name |
|------|-----|-----|------|
|------|-----|-----|------|

Notes:
 [FOX 45_I]

| | | | |
|----|-----------------|---|-----------------------|
| 1 | 2.4419.140.1 | 1 | oil filter element |
| 2 | 2.3319.511.0 | 1 | pipe union |
| 3 | 0.320.1550.0 | 1 | support |
| 4 | 0.037.1552.0/10 | 1 | gasket |
| 5 | 0.316.1552.3 | 1 | tube |
| 6 | 0.316.1553.3 | 1 | tube |
| 7 | 2.1560.016.0 | 8 | gasket 20.2 x 26 |
| 8 | 2.1470.006.2 | 3 | lock washer 10 |
| 9 | 2.0112.207.2 | 2 | screw m 8 p 1.25 x 20 |
| 10 | 0.320.1551.0 | 1 | flange |
| 11 | 2.0112.309.2 | 1 | screw m 10 p.1.5 x 25 |
| 13 | 2.4419.130.3 | 1 | gasket |
| 15 | 2.4419.130.2 | 1 | valve |
| 16 | 2.3332.006.1 | 4 | pipe fitting |

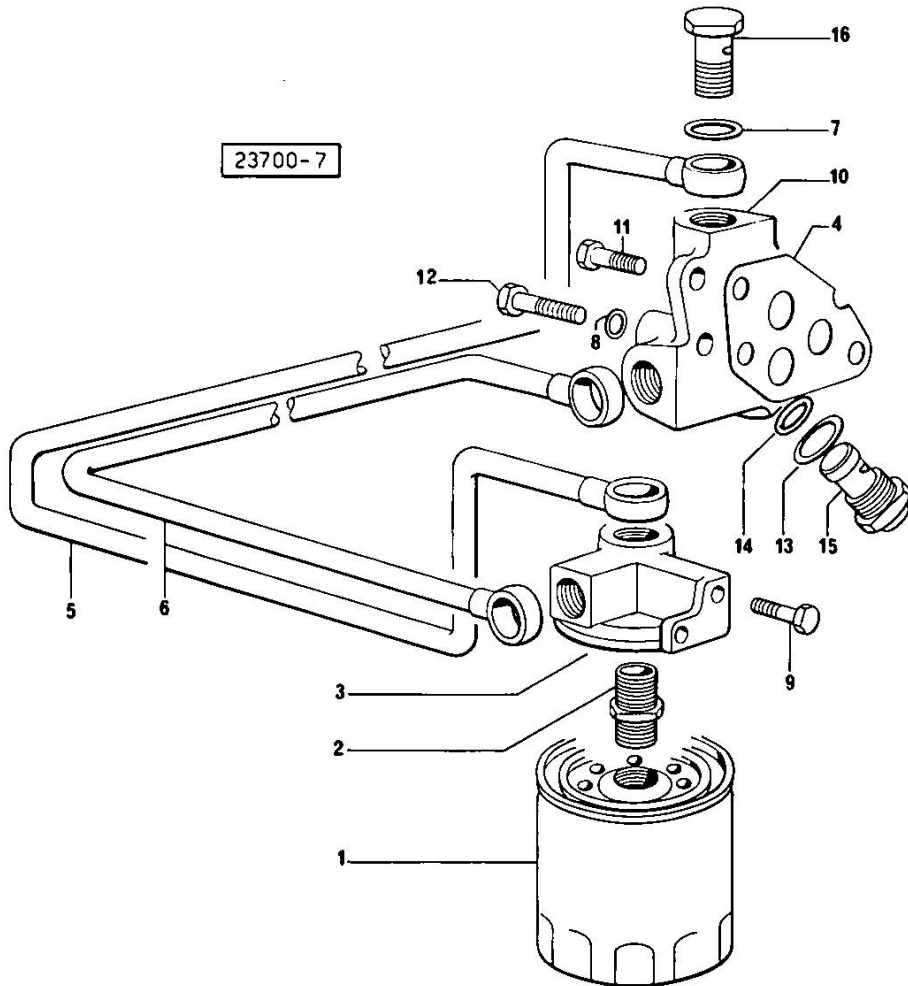



Suggest:

For more complete manuals. Please go to the home page.

<https://www.ebooklibonline.com>

If the above button click is invalid. Please download this document first, and then click the above link to download the complete manual.

Thank you so much for reading

Section: ENGINE

FUEL SUPPLY SYSTEM

| Fig. | P/n | QTY | Name |
|------|-----|-----|------|
|------|-----|-----|------|

Notes:
[FOX 45_I]

| | | | |
|----|--------------|---|-----------------------------|
| 1 | 0.029.1615.0 | 1 | bracket |
| 2 | 0.029.1616.0 | 2 | adjust.rocker |
| 3 | 0.029.1652.0 | 4 | pin |
| 4 | 0.029.1653.0 | 4 | roller |
| 5 | 0.029.1618.0 | 1 | sleeve |
| 6 | 0.029.1611.0 | 2 | gear |
| 7 | 2.1120.105.2 | 2 | self-locking nut m 8 p.1.25 |
| 8 | 0.027.1670.0 | 1 | fork |
| 9 | 0.320.1621.3 | 1 | lever |
| 10 | 2.1631.311.0 | 1 | roll pin 3x24 |
| 11 | 2.3519.004.1 | 1 | fork |
| 12 | 2.1679.018.0 | 2 | pin |
| 13 | 2.1599.109.0 | 2 | shoulder ring |
| 14 | 2.1630.006.0 | 2 | roll pin 2x12 |
| 15 | 2.1011.103.2 | 1 | nut m 6 p.1 |
| 16 | 0.029.1627.0 | 1 | stay |
| 17 | 2.4049.054.1 | 1 | spring |
| 18 | 0.027.1626.3 | 1 | rod |
| 19 | 0.029.1624.0 | 1 | spring holder |
| 20 | 0.000.4699.0 | 1 | fork |
| 21 | 2.1011.103.2 | 4 | nut m 6 p.1 |
| 22 | 0.027.1674.0 | 1 | rod |

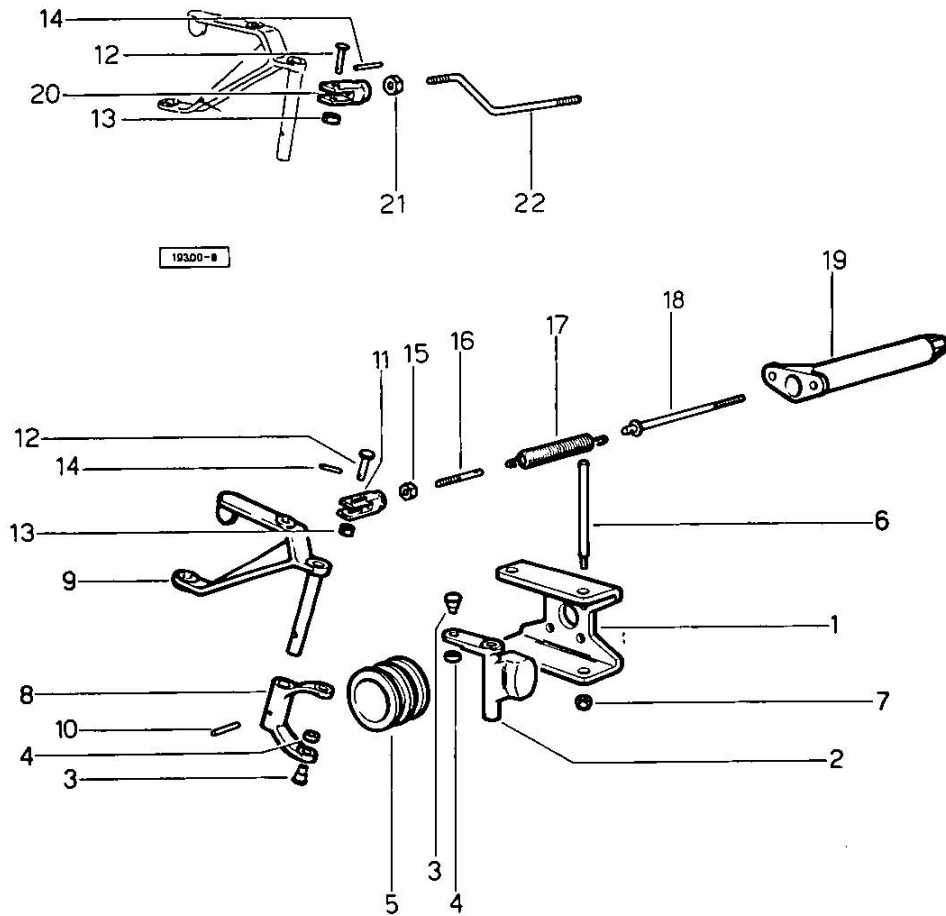

Section: ENGINE

FUEL FEED - INJECTION PUMP

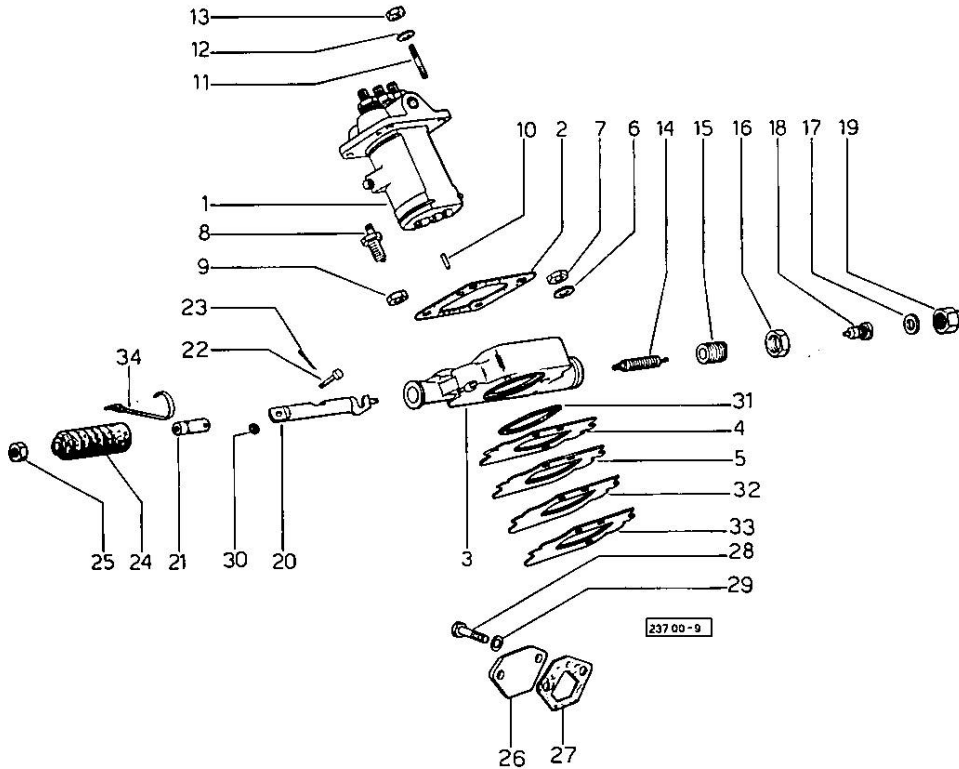

| Fig. | P/n | QTY | Name |
|---------------|-----------------|-----|---------------------------------|
| Notes: | | | |
| [FOX 45_I] | | | |
| 1 | 2.4639.060.0 | 1 | injector pump ☞ 01.00.10 |
| 2 | 0.035.1651.0 | 1 | gasket |
| 3 | 0.035.1610.0/10 | 1 | support |
| 4 | 0.035.1652.0 | 1 | shim mm 0.1 |
| 5 | 0.035.1653.0 | 1 | shim mm 0.20 |
| 6 | 2.1470.007.2 | 2 | lock washer 12 |
| 7 | 2.1011.422.2 | 2 | nut m 12 p.1.25 |
| 8 | 0.027.1663.3 | 1 | start device |
| 9 | 2.1099.033.1 | 1 | special nut |
| 10 | 2.1653.306.0 | 1 | pin |
| 11 | 2.0432.003.1 | 4 | stud bolt m 8 p.1.25 / p.1 x 20 |
| 12 | 2.1470.004.2 | 4 | lock washer 8 |
| 13 | 2.1011.405.2 | 4 | nut m 8 p.1 |
| 14 | 2.4049.063.1 | 1 | spring |
| 15 | 0.027.1661.0 | 1 | screw |
| 16 | 2.1019.004.1 | 1 | special nut |
| 17 | 2.1560.017.0 | 1 | gasket 22.2 x 27 |
| 18 | 0.035.1655.0 | 1 | pin |
| 19 | 2.1099.045.2 | 1 | special nut |
| 20 | 0.035.1654.0 | 1 | rod |
| 21 | 0.000.5620.0 | 1 | fork m 6 |
| 22 | 2.1670.001.2 | 1 | pin 5x14x12 |
| 23 | 2.1690.106.0 | 1 | split pin |
| 24 | 0.000.5617.0 | 1 | guard |
| 25 | 2.1011.103.2 | 1 | nut m 6 p.1 |
| 26 | 0.320.1651.0 | 1 | small cover |
| 27 | 0.029.1655.0 | 1 | gasket mm 1.00 |
| 27 | 0.034.1659.0 | 1 | gasket mm 0.5 |
| 27 | 0.034.1660.0 | 1 | gasket mm 0.20 |
| 28 | 2.0112.204.2 | 2 | screw m 8 p.1.25x14 |
| 29 | 2.1474.009.1 | 2 | spring washer 8 |
| 30 | 2.1599.196.2 | 1 | shoulder ring |
| 31 | 2.1539.023.0 | 1 | special oil seal |
| 32 | 0.038.1656.0 | 2 | shim |
| 33 | 0.038.1655.0 | 2 | shim |
| 34 | 2.6859.007.0 | 1 | clamp |

<https://www.ebooklibonline.com>

Hello dear friend!

Thank you very much for reading.

Enter the link into your browser.

The full manual is available for immediate download.

<https://www.ebooklibonline.com>