

**CRANKCASE**

Fig.	P/n	QTY	Name
------	-----	-----	------

**Notes:**

[EXPLORER 90.4 -> ZKDCH80200TS20001]

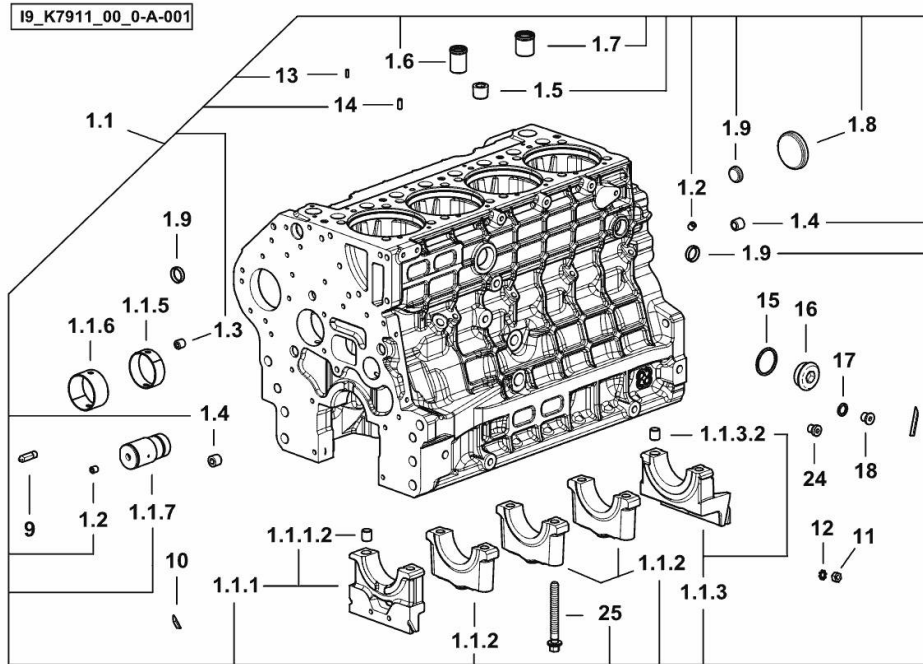

1.1	0.020.4332.3/20	1	crankcase
1.1.1	0.019.5106.3	1	support
1.1.1.2	2.1699.165.0	1	bush 12.3x15x16
1.1.2	0.019.5107.7	3	support
1.1.3	0.019.5108.3	1	support
1.1.3.2	2.1699.165.0	1	bush 12.3x15x16
1.1.5	0.065.1140.0	4	special bushing 59X55X20
1.1.6	0.065.1141.0	1	special bushing 59X55X30
1.1.7	0.019.4412.0	1	pin
1.2	2.3130.001.7	15	plug
1.3	2.3130.002.7	2	plug 1/4" gas
1.4	2.3130.003.7	4	plug 3/8" gas
1.5	2.3130.005.7	3	plug
1.6	0.019.4146.0	1	tube
1.7	0.019.6173.0	1	tube
1.8	2.3179.012.0	1	plug 60
1.9	2.3171.010.4	5	plug 25
9	0.019.4415.0/10	1	tube
10	0.066.1152.0/10	4	gasket
11	2.1011.405.2	2	nut m 8 p.1
12	2.1470.004.2	4	lock washer 8
13	2.1651.305.0	4	pin 4 x 12
14	2.1651.507.0	4	pin 6 x 16
15	2.1560.027.0	1	copper gasket 38.3x44
16	2.3139.031.2	1	plug
17	2.1560.010.0	1	gasket 14.2 x 20
18	2.3199.292.0	1	plug 1/4" gas
24	2.3139.024.2	1	plug m 12 p.1.5 (-> 10001 )
25	2.0399.367.7	10	screw

**CYLINDER LINER O-RING**

Fig.	P/n	QTY	Name
------	-----	-----	------

**Notes:**

[EXPLORER 90.4 -> ZKDCH80200TS20001]

16	2.1539.259.0	8	special oil seal 107.62x2.62
----	--------------	---	------------------------------

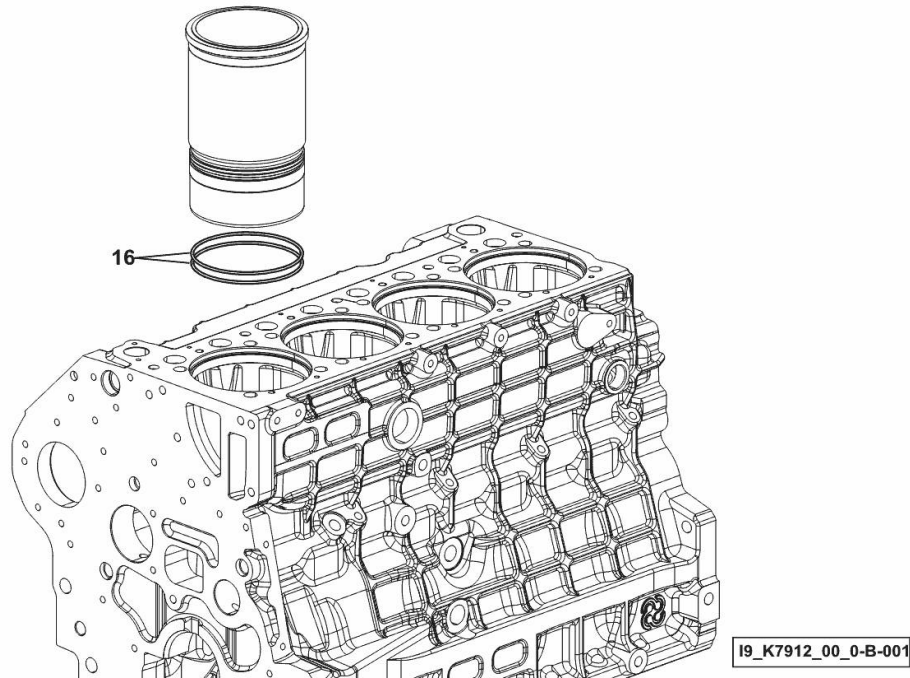

**EXPLORER 90.4 -> ZKDCH80200TS20001**

Section: B0 - ENGINE

Ref: B0.01.5 (1)

**SIDE PLUG FOR CYLINDER BLOCK**

Fig.	P/n	QTY	Name
------	-----	-----	------

**Notes:**

- FOR TYPES WITH TRAILER AIR BRAKING [EXPLORER 90.4 -> ZKDCH80200TS20001]

12	2.1560.018.0	1	gasket 22.2 x 29
13	2.3120.102.0	1	plug

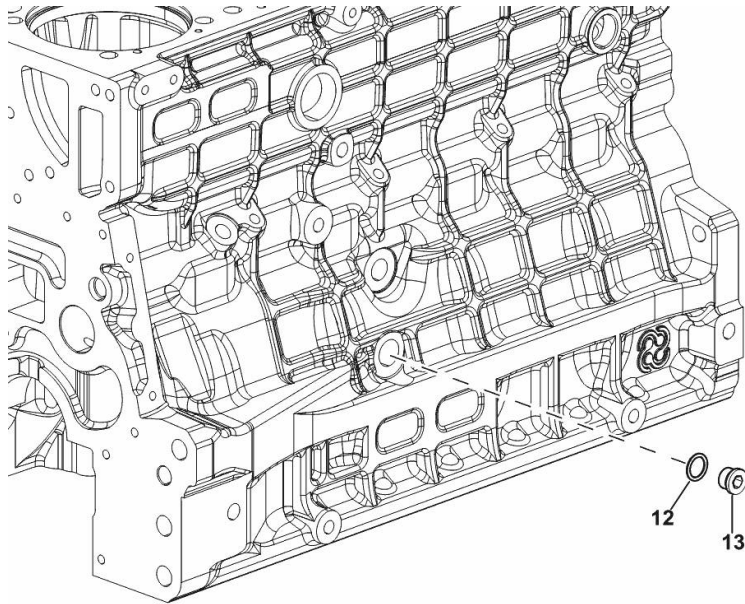

9\_K8015\_03\_0-B-001

**<https://www.ebooklibonline.com>**

Hello dear friend!

Thank you very much for reading.

Enter the link into your browser.

The full manual is available for immediate download.

**<https://www.ebooklibonline.com>**

EXPLORER 90.4 -> ZKDCH80200TS20001

Section: B0 - ENGINE

Ref: B0.01.6 (1)

**MONOBLOC ENGINE-GEARBOX CONNECTING FLANGE**

Fig.	P/n	QTY	Name
------	-----	-----	------

Notes:

[EXPLORER 90.4 -> ZKDCH80200TS20001]

1	2.1475.005.2	2	washer 14
2	2.0112.524.2	2	screw m 14 p.2 x 75
3	2.0112.624.2	2	screw m 16 p.2 x 75
4	2.1475.006.2	2	spring washer 16
6	2.0439.250.7	1	stud bolt m 12 / m 10 x 30
7	0.011.9294.0/10	1	bush
25	0.019.1488.0	1	flange
26	2.0112.511.2	8	screw m 14 p.2 x 30
27	2.1651.912.0	2	cylindrical plug 12x28
28	2.1651.917.0	1	cylindrical plug 12x40
29	2.0432.257.7	1	stud bolt m 12 p.1.75 - 1.25 x 30

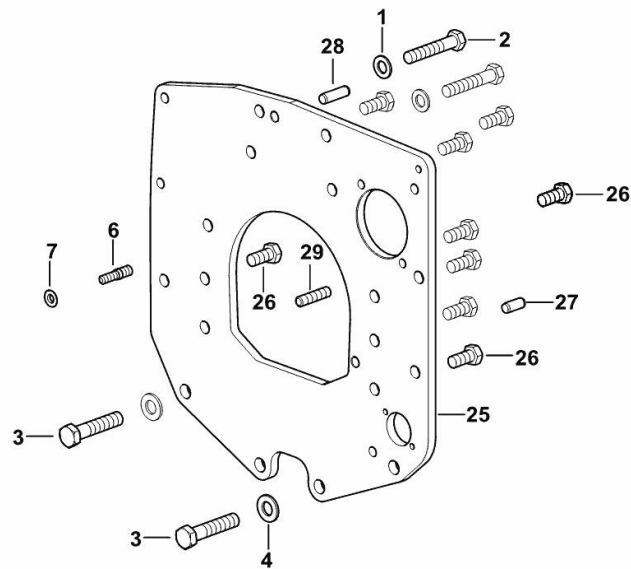

[9\_K7411\_01\_0-A-001]

**ENGINE FLYWHEEL**

Fig.	P/n	QTY	Name
------	-----	-----	------

**Notes:**

[EXPLORER 90.4 -> ZKDCH80200TS20001]

1	0.019.1948.3	1	flywheel
1.2	0.065.1242.0	1	crown wheel Z = 123
2	2.0399.368.0	6	screw

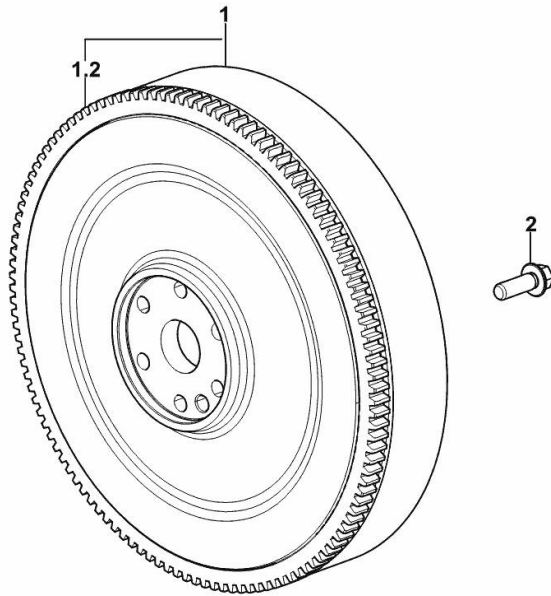

9\_K7912\_03\_0-A-001

**CRANKSHAFT PULLEY**

Fig.	P/n	QTY	Name
------	-----	-----	------

**Notes:**

[EXPLORER 90.4 -> ZKDCH80200TS20001]

1	0.019.9925.0	1	pulley
2	0.019.6668.0	1	flange
3	0.065.1256.0	2	ring 45x52
4	2.1579.865.0	1	spacer 45.2x51.8x10
5	2.0439.195.7	1	stud bolt m 20 p.1.5x80
6	2.1019.094.7	1	nut m 20 p.1.5
7	2.0112.320.2	6	screw m 10 p.1.5 x 55
8	2.1470.006.2	6	lock washer 10
9	2.1720.006.0	1	key 4x6.5
10	0.019.6413.0	1	gear wheel
11	2.1651.505.0	1	cylindrical plug 6x12

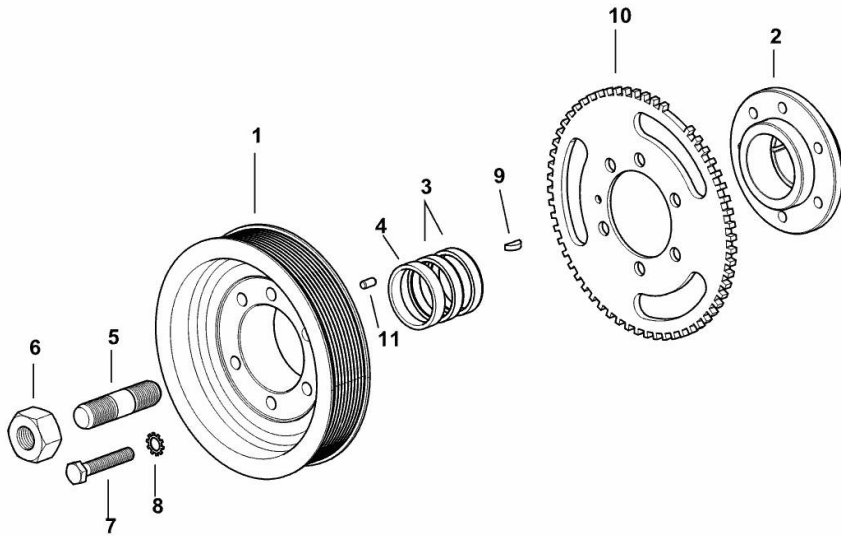

19\_K7812\_01\_0-A-001

**BELT AND TENSIONER**

Fig.	P/n	QTY	Name
------	-----	-----	------

**Notes:**

- WITH MANUAL AIR CONDITIONING [EXPLORER 90.4 -> ZKDCH80200TS20001] 10001 <-

1	2.4119.218.0/10	1	belt PK 10 L=2017
2	0.021.4446.4	1	tensioner
3	0.019.9869.4/10	3	pulley guide
4	2.0312.214.2	5	screw m 8 p.1.25 x 40
5	0.020.4604.0	1	support
7	2.0399.380.2	1	screw
8	2.0399.379.2	1	small column
9	2.1480.015.2	1	washer 10
10	2.1480.014.2	5	washer 8
11	2.1310.004.2	2	flat washer 8.4x17
12	2.0314.322.2	1	screw
13	2.0112.209.2	2	screw m 8 p 1.25 x 25
14	2.1310.006.2	1	flat washer 10.5x21

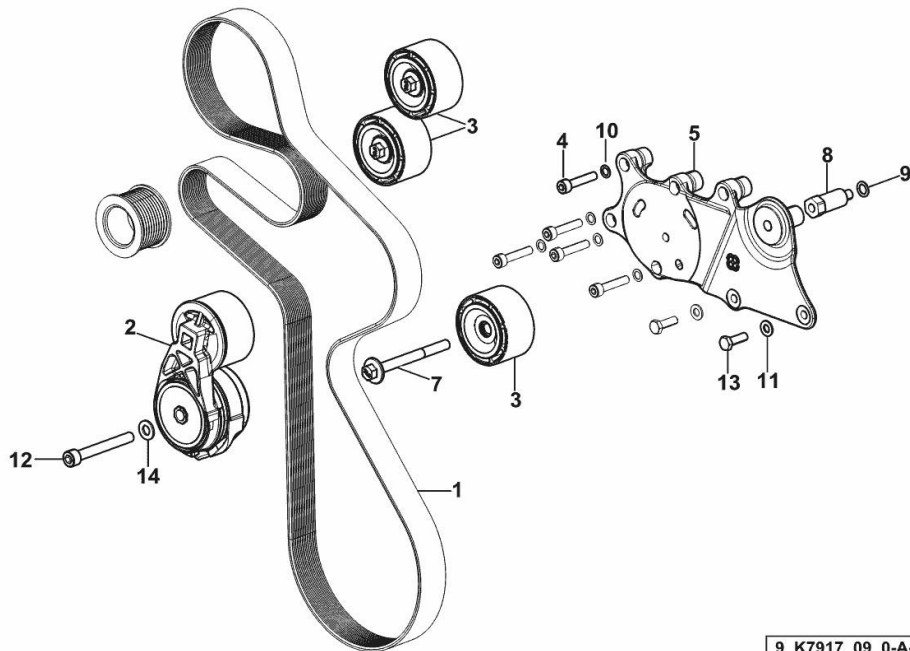

9\_K7917\_09\_0-A-001

**BELT AND TENSIONER**

Fig.	P/n	QTY	Name
------	-----	-----	------

**Notes:**

- WITH MANUAL AIR CONDITIONING [EXPLORER 90.4 -> ZKDCH80200TS20001]

1	2.4119.218.0/10	1	belt PK 10 L=2017
3	0.019.9869.4/10	3	pulley guide
4	2.0312.214.2	5	screw m 8 p.1.25 x 40
5	0.020.4604.0	1	support
7	2.0399.380.2	1	screw
8	2.0399.379.2	1	small column
9	2.1480.015.2	1	washer 10
10	2.1480.014.2	5	washer 8
11	2.1310.004.2	2	flat washer 8.4x17
13	2.0112.209.2	2	screw m 8 p 1.25 x 25

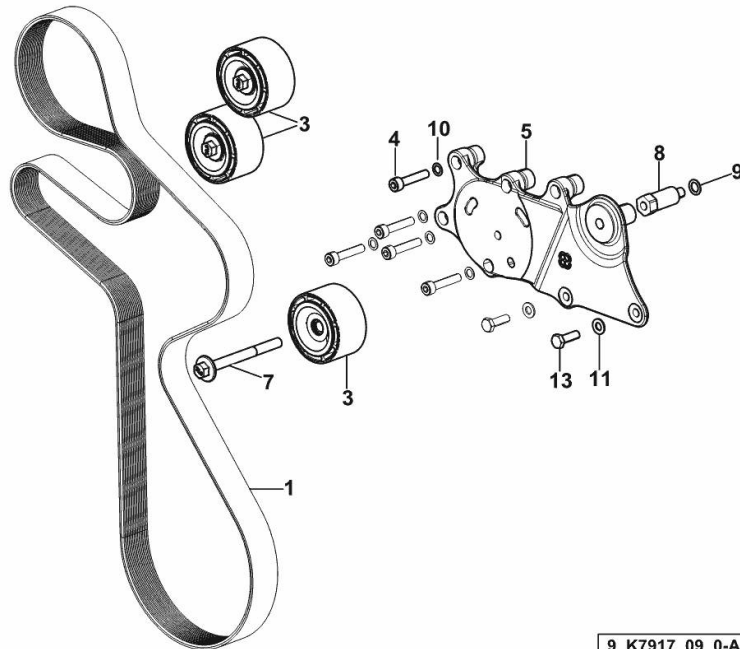

9\_K7917\_09\_0-A-002

**BELT AND TENSIONER**

Fig.	P/n	QTY	Name
------	-----	-----	------

**Notes:**

WITHOUT AIR-CONDITIONING [EXPLORER 90.4 -> ZKDCH80200TS20001]

1	2.4119.219.0	1	belt PK 10 L=1498
2	0.021.4446.4	1	tensioner
3	0.019.9869.4/10	2	pulley guide
4	2.0312.214.2	5	screw m 8 p.1.25 x 40
5	0.020.4604.0	1	support
7	2.0399.380.2	1	screw
8	2.0399.379.2	1	small column
9	2.1480.015.2	1	washer 10
10	2.1480.014.2	5	washer 8
11	2.1310.004.2	2	flat washer 8.4x17
12	2.0314.322.2	1	screw
13	2.0112.209.2	2	screw m 8 p 1.25 x 25
14	2.1310.006.2	1	flat washer 10.5x21

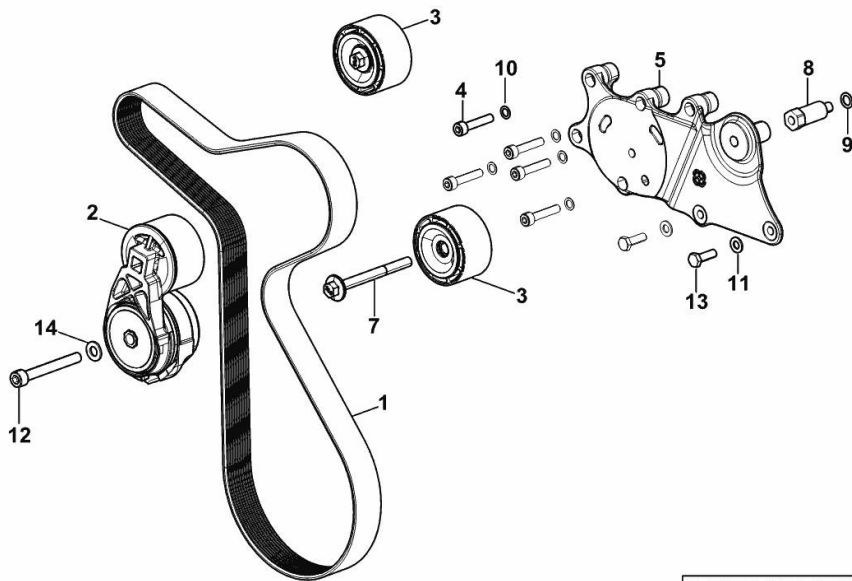

9\_K7917\_10\_0-A-001



**Suggest:**

**For more complete manuals. Please go to the home page.**

**<https://www.ebooklibonline.com>**

**If the above button click is invalid. Please download this document first, and then click the above link to download the complete manual.**

**Thank you so much for reading**

**BELT AND TENSIONER**

Fig.	P/n	QTY	Name
------	-----	-----	------

**Notes:**

WITHOUT AIR-CONDITIONING [EXPLORER 90.4 -> ZKDCH80200TS20001]

1	2.4119.219.0	1	belt PK 10 L=1498
3	0.019.9869.4/10	2	pulley guide
4	2.0312.214.2	5	screw m 8 p.1.25 x 40
5	0.020.4604.0	1	support
7	2.0399.380.2	1	screw
8	2.0399.379.2	1	small column
9	2.1480.015.2	1	washer 10
10	2.1480.014.2	5	washer 8
11	2.1310.004.2	2	flat washer 8.4x17
13	2.0112.209.2	2	screw m 8 p 1.25 x 25

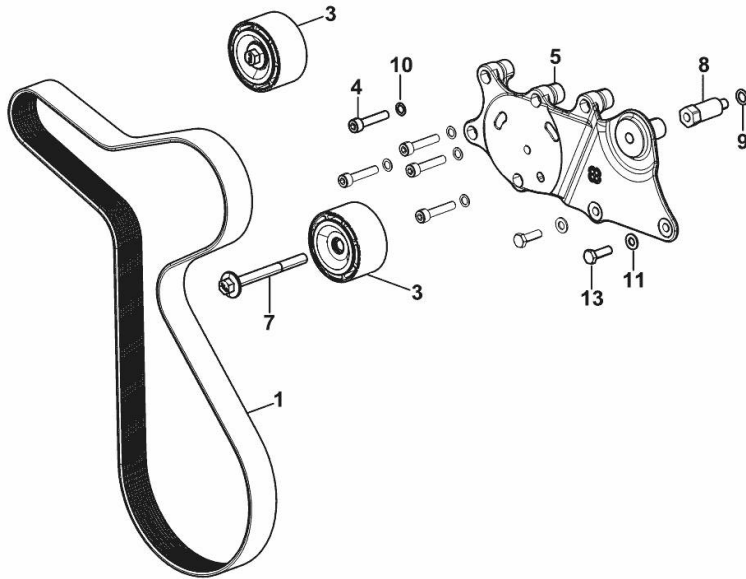

9\_K7917\_10\_0-A-002

**TENSION ROLLER**

Fig.	P/n	QTY	Name
------	-----	-----	------

**Notes:**

[EXPLORER 90.4 -&gt; ZKDCH80200TS20001]

1	0.019.9867.4	1	tensioner
2	2.1310.006.2	1	flat washer 10.5x21
3	2.0314.322.2	1	screw

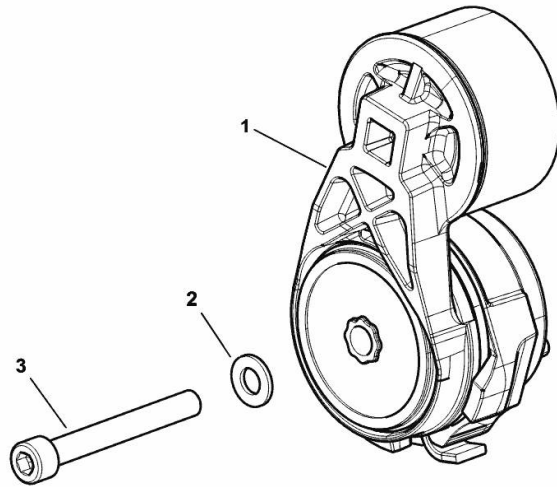

9\_IB117\_10\_0-A-001

**<https://www.ebooklibonline.com>**

Hello dear friend!

Thank you very much for reading.

Enter the link into your browser.

The full manual is available for immediate download.

**<https://www.ebooklibonline.com>**