

Section: ENGINE  
**CRANKCASE**

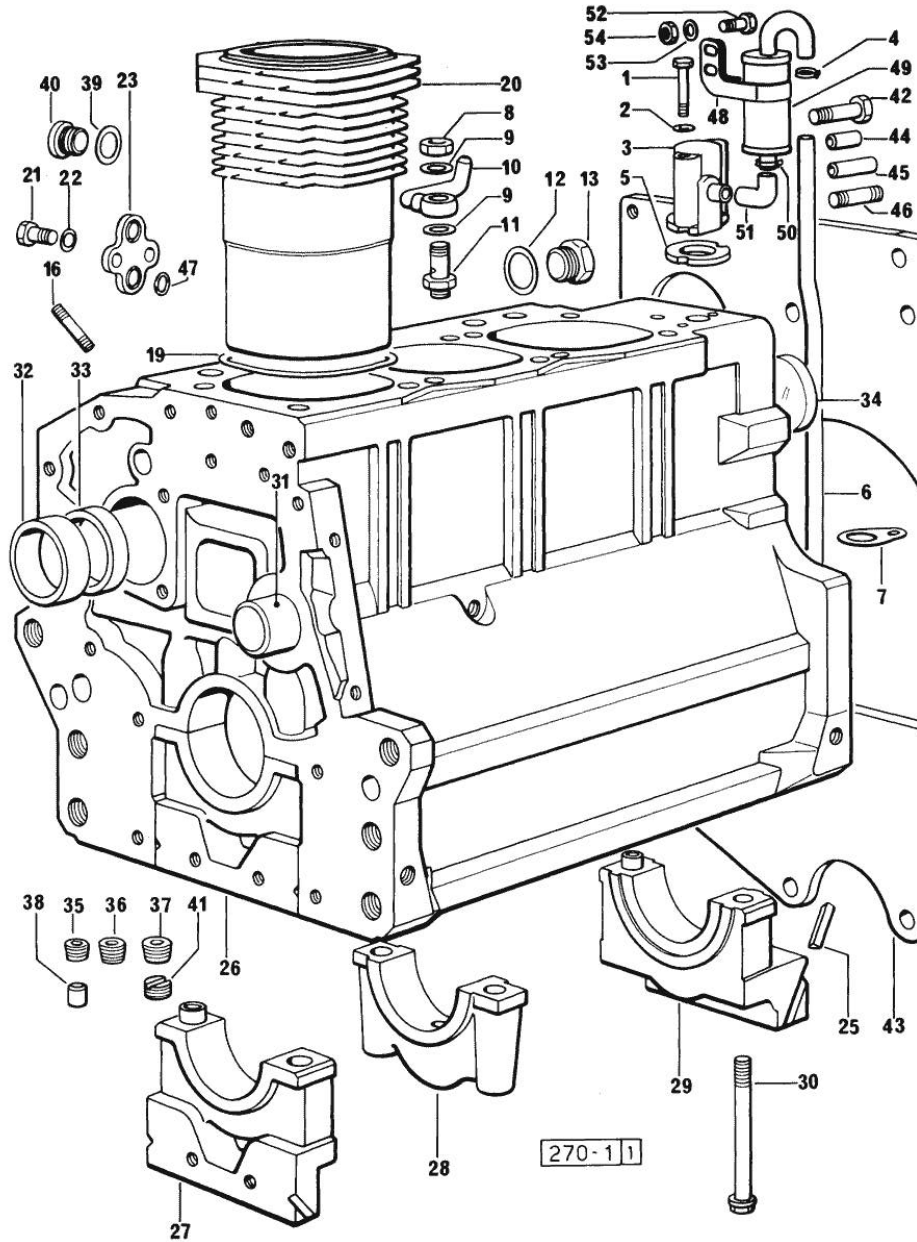

Fig.	P/n	QTY	Name
------	-----	-----	------

Notes:  
 [EXPLORER 55]

0	0.069.0050.6	1	gasket set FOR INSTALLATION OF 916.3 A ENGINE
0	0.085.0050.6	1	gasket set FOR INSTALLATION OF 1000.3 A ENGINE
1	2.0312.219.2	2	screw m 8 p.1.25x65
2	2.1470.004.2	2	lock washer 8
3	0.065.1143.3	1	body 1139 <=
3	0.065.1143.3/10	1	body => 1140
4	2.6859.072.2	1	clamp
5	0.065.1156.0	2	gasket
6	0.065.1155.0	1	old part number 1139 <=
6	0.065.1155.0/10	1	tube => 1140
7	0.065.1157.0	1	bracket
8	2.1099.108.2	3	special nut m 10 p.1
9	2.1560.006.0	6	gasket 10.2 x 16
10	0.065.1158.2	3	old part number
11	0.065.1160.3/20	3	valve
12	2.1539.047.2	1	old part number
13	2.3199.405.2	1	plug m 28 p.1.5
16	2.0439.154.1	9	old part number
19	2.1519.096.0	3	oil seal X 1000.3 A
19	2.1589.154.0	3	shoulder ring X 916.3 A
19	2.1589.155.0	3	shoulder ring X 916.3 A
19	2.1589.156.0	3	shoulder ring X 916.3 A
20	0.065.1120.0/10	3	engine cylinder X 916.3 A
20	0.085.1120.0	3	old part number X 1000.3 A
21	2.0112.207.2	2	screw m 8 p 1.25 x 20
22	2.1470.004.2	2	lock washer 8
23	0.065.1163.0	1	flange
25	0.066.1152.0	3	gasket
26	0.085.1110.4	1	crankcase

Section: ENGINE

## CRANKCASE

Fig.	P/n	QTY	Name
			X 1000.3 A
26	9.06999.41.1	1	crankcase
			X 916.3 A
27	0.065.1112.7	1	support
27	2.1699.165.0	1	bush 12.3x15x16
28	0.065.1114.7	2	support
29	0.065.1116.7	1	support
29	2.1699.165.0	1	bush 12.3x15x16
30	0.065.1117.0	8	screw m 12 x 100
31	0.066.1151.0	1	pin
32	0.065.1141.0	1	special bushing 59X55X30
33	0.065.1140.0	3	special bushing 59X55X20
34	2.3179.012.0	1	plug 60
35	2.3130.001.1	10	plug 1/8" gas
36	2.3130.002.1	2	plug 1/4" gas
37	2.3130.003.1	7	plug 3/8" gas
38	2.3199.092.0	3	plug 8 x 12
39	2.1560.017.0	1	gasket 22.2 x 27
40	2.3120.002.4	1	plug m 22 x 1.5
41	2.1324.011.0	1	plug
42	2.0112.511.1	8	screw m 14 p.2 x 30
43	0.066.1130.0	1	flange
			1436 <=
43	0.066.1130.0/20	1	flange
			=> 1437
44	2.1651.912.0	2	cylindrical plug 12x28
45	2.1651.917.0	1	cylindrical plug 12x40
46	2.0432.255.1	2	stud bolt m 12 p.1.75 - 12 p1.25x25
47	2.1539.048.0	2	special oil seal 20.35x1.78
48	2.6859.074.2/10	1	clamp
49	0.065.1165.2	1	sediment bowl
			=> 1140
50	2.6859.073.2	2	clamp
51	0.065.1166.0	1	sleeve
			=> 1140
52	2.0112.004.2	1	screw m 6 p.1 x 14
53	2.1470.002.2	1	lock washer 6
54	2.1011.103.2	1	nut m 6 p.1

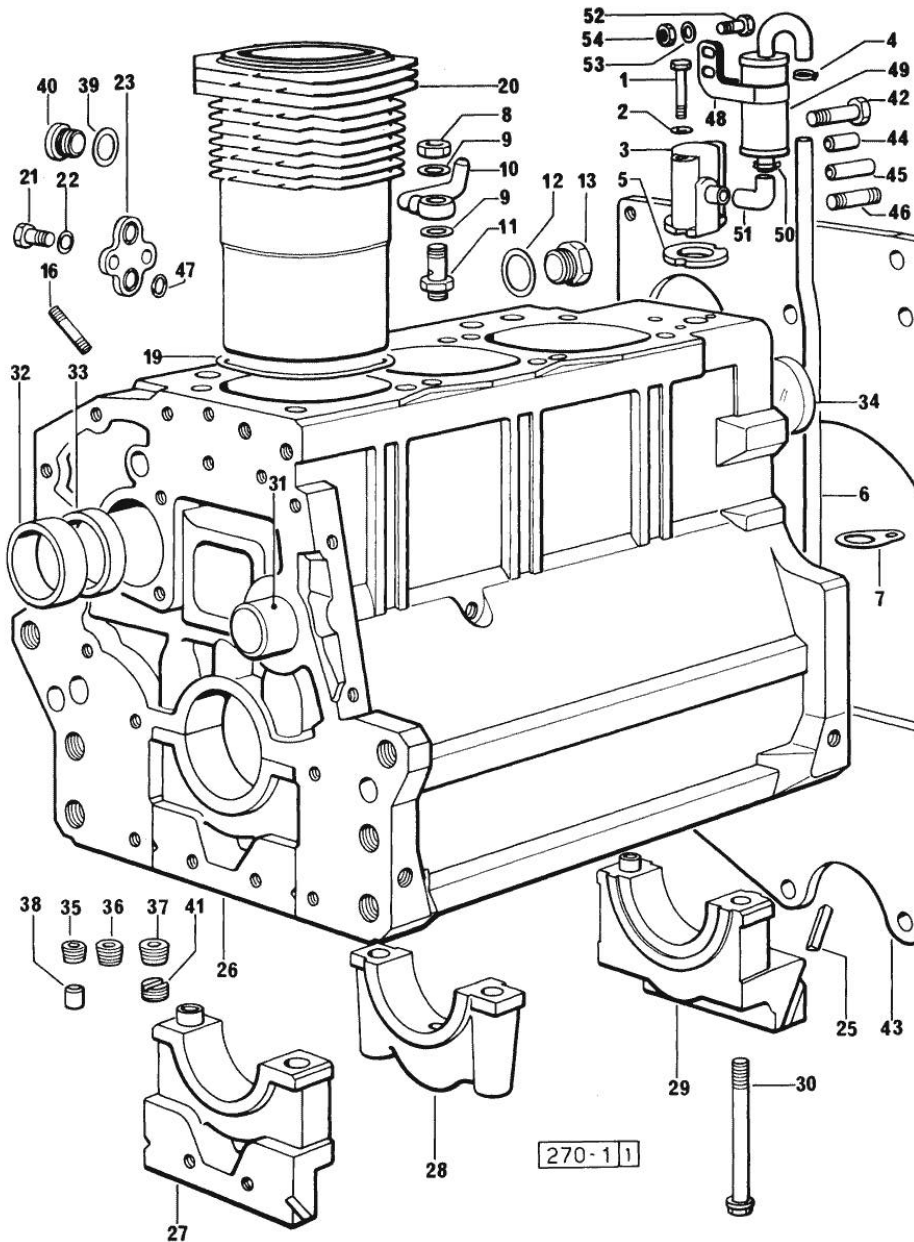

Section: ENGINE  
TIMING CASE

Fig.	P/n	QTY	Name
------	-----	-----	------

Notes:  
[EXPLORER 55]

1	0.065.1132.0/20	1	guard
2	0.065.1150.0/10	1	gasket
3	0.065.1152.0	1	gasket
4	0.065.1157.0	1	bracket
5	2.1470.004.2	4	lock washer 8
6	2.0112.205.2	2	screw m 8 p.1.25 x 16
7	2.0432.001.1	2	stud bolt m 14 p.2-1.5x35
8	2.1011.405.2	2	nut m 8 p.1
9	2.0312.208.1	8	screw m 8 p.1.25 x 25
10	2.1480.014.1	15	washer 8
11	2.0439.154.1	2	old part number
13	2.0312.214.1	3	screw m 8 p.1.25 x 40
13	2.0312.219.2	4	screw m 8 p.1.25x65
14	2.1529.072.0	1	oil seal

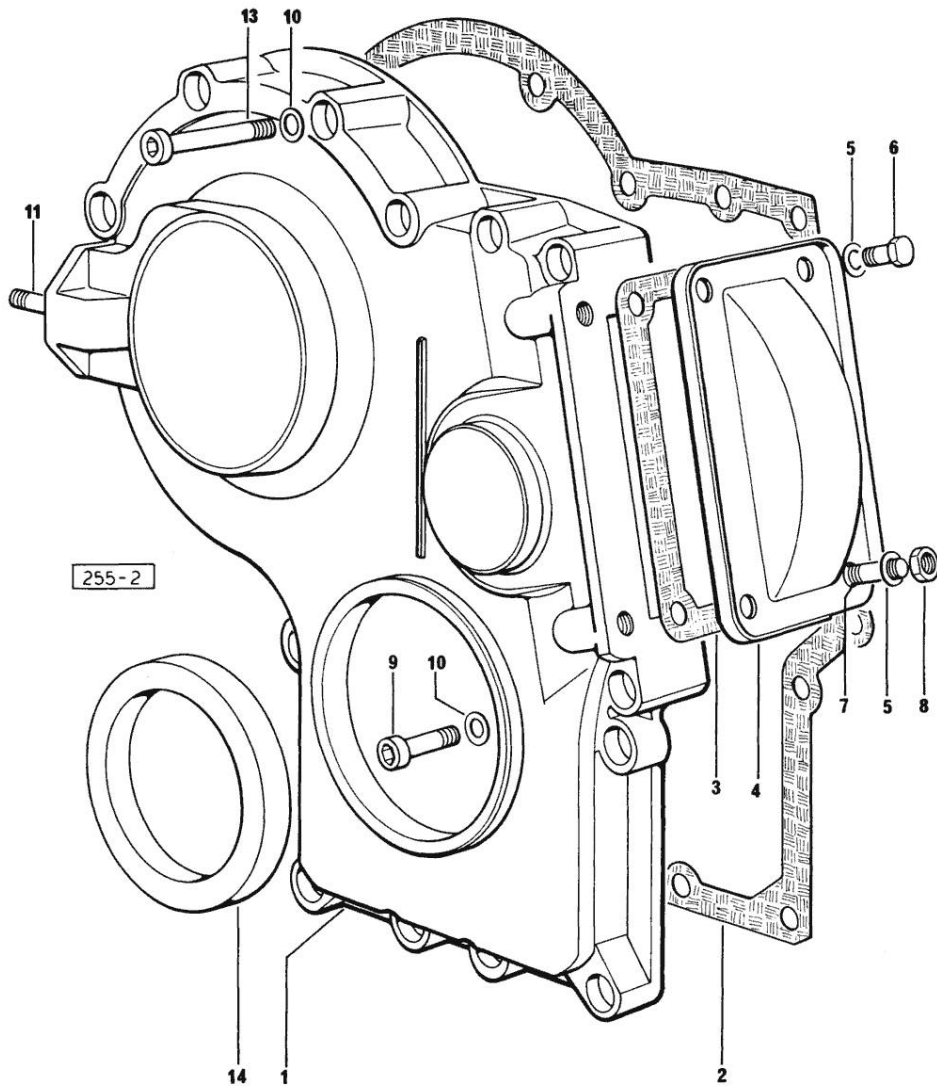

**<https://www.ebooklibonline.com>**

Hello dear friend!

Thank you very much for reading.

Enter the link into your browser.

The full manual is available for immediate download.

**<https://www.ebooklibonline.com>**

Section: ENGINE

**CRANKSHAFT**

Fig.	P/n	QTY	Name
------	-----	-----	------

Notes:  
[EXPLORER 55]

1	0.069.1210.3	1	crankshaft X 916.3 A
1	0.085.1210.3	1	crankshaft X 1000.3 A
5	0.065.1220.3/10	3	engine connecting rod X 916.3 A
5	0.078.1220.3/10	3	engine connecting rod - X 1000.4 W X 1000.3 A
6	2.0139.021.0	6	screw
7	0.065.1227.0	3	special bushing X 916.3 A
7	2.1559.114.0/10	3	special bushing X 1000.3 A
8	2.1411.013.1	6	circlip 32 X 916.3 A
8	2.1411.014.1	8	circlip 35 X 1000.3 A
9	0.065.1236.0	3	piston pin X 916.3 A
9	0.078.1236.0	3	piston pin Ø 18 / Ø 35 / L = mm 86 X 1000.3 A
10	2.1720.006.0	2	key 4x6.5
11	0.065.1248.0	1	old part number
12	2.1589.137.0	1	shoulder ring 71x110x1
12	2.1589.138.0	1	old part number
13	2.0399.095.2/10	1	screw
14	2.1599.503.2	1	shoulder ring
15	2.0112.317.2	6	screw m 10 p.1.5 x 45
16	2.1470.006.2	6	lock washer 10
17	0.065.1244.0	1	pulley
18	0.065.1254.0	1	gasket
19	0.065.1253.0/10	1	cover
20	2.1529.073.0	1	special oil seal 110x130x13
21	2.0112.207.2	9	screw m 8 p 1.25 x 20
22	2.1474.009.2	9	spring washer 8
23	0.065.1225.0	6	con.rod half bushing STANDARD - A = 28.75 -> 29.00
23	0.065.1225.7	6	con.rod half bushing - mm 0.25
23	0.065.1225.8	6	con.rod half bushing - mm 0.50
24	0.065.1215.0	4	main half bushing STANDARD
24	0.065.1215.7	4	main half bushing - mm 0.25
24	0.065.1215.8	4	main half bushing - mm 0.50

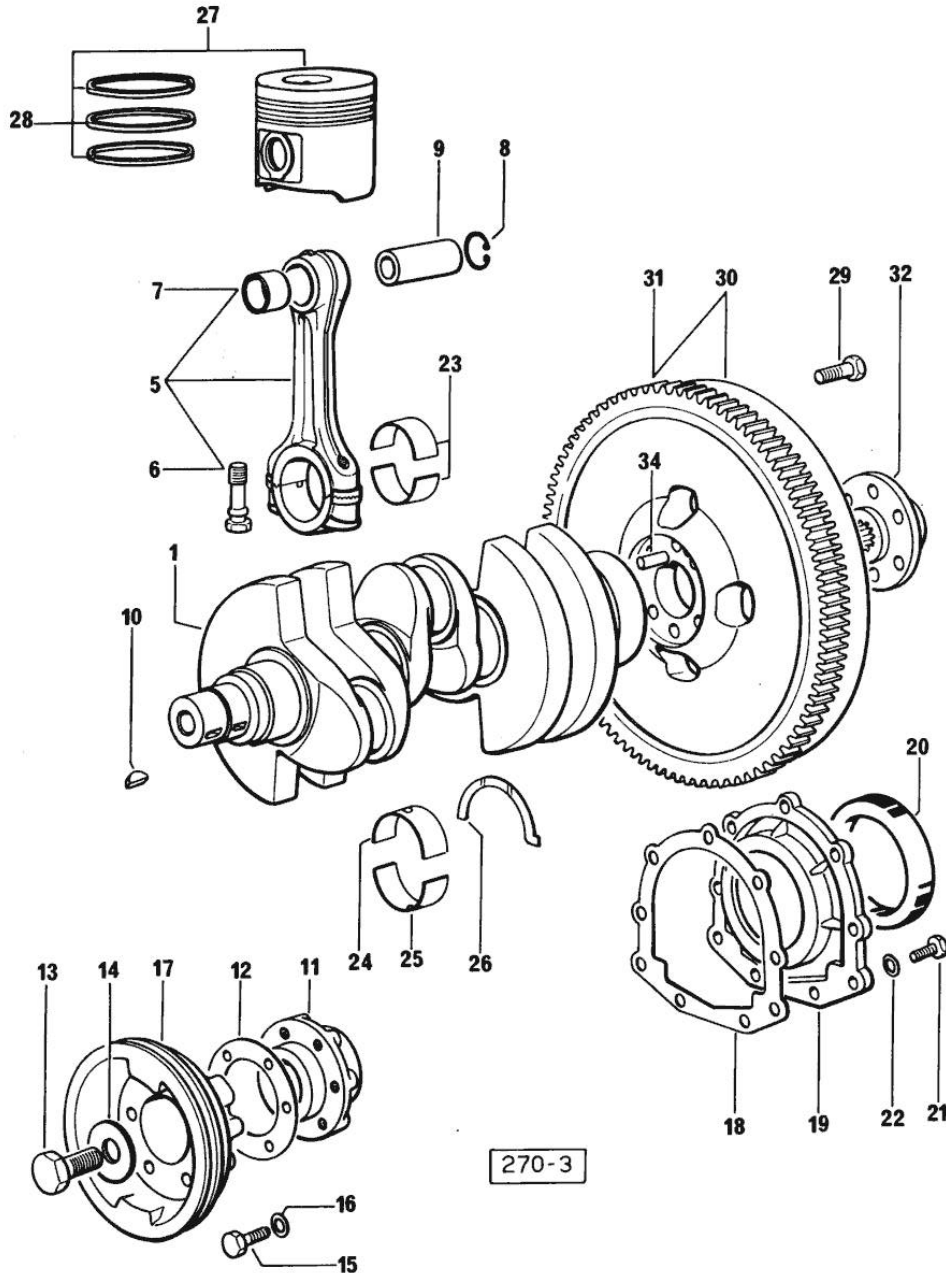

CRANKSHAFT

Fig.	P/n	QTY	Name
25	0.065.1216.0	4	main half bushing
25	0.065.1216.7	4	main half bushing - mm 0.25
25	0.065.1216.8	4	main half bushing - mm 0.50
26	0.065.1218.0	4	shim STANDARD
26	0.065.1218.7	4	shim + mm 0.10
26	0.065.1218.8	4	shim + mm 0.15
27	0.069.0060.6	3	complete piston STANDARD X 916.3 A
27	0.086.0060.6	3	complete piston X 1000.3 A
28	0.065.0052.6	3	piston ring set X 916.3 A
28	0.086.0052.6	3	piston ring set X 1000.3 A
29	2.0139.022.2	6	screw m 12 p.1.25x55
30	0.065.1247.3/10	1	old part number -> 1427
30	0.065.1247.3/20	1	old part number 1704 <=
			ORDINARE ANCHE: 255.2320.3/10 N.6 2.0112.207.2 N.6 2.1474.009.1 N.3 2.1699.173.0
31	0.065.1242.0	1	crown wheel Z = 123
32	0.255.2525.0/10	1	flange
34	2.1652.915.0	1	cylindrical plug 12x35

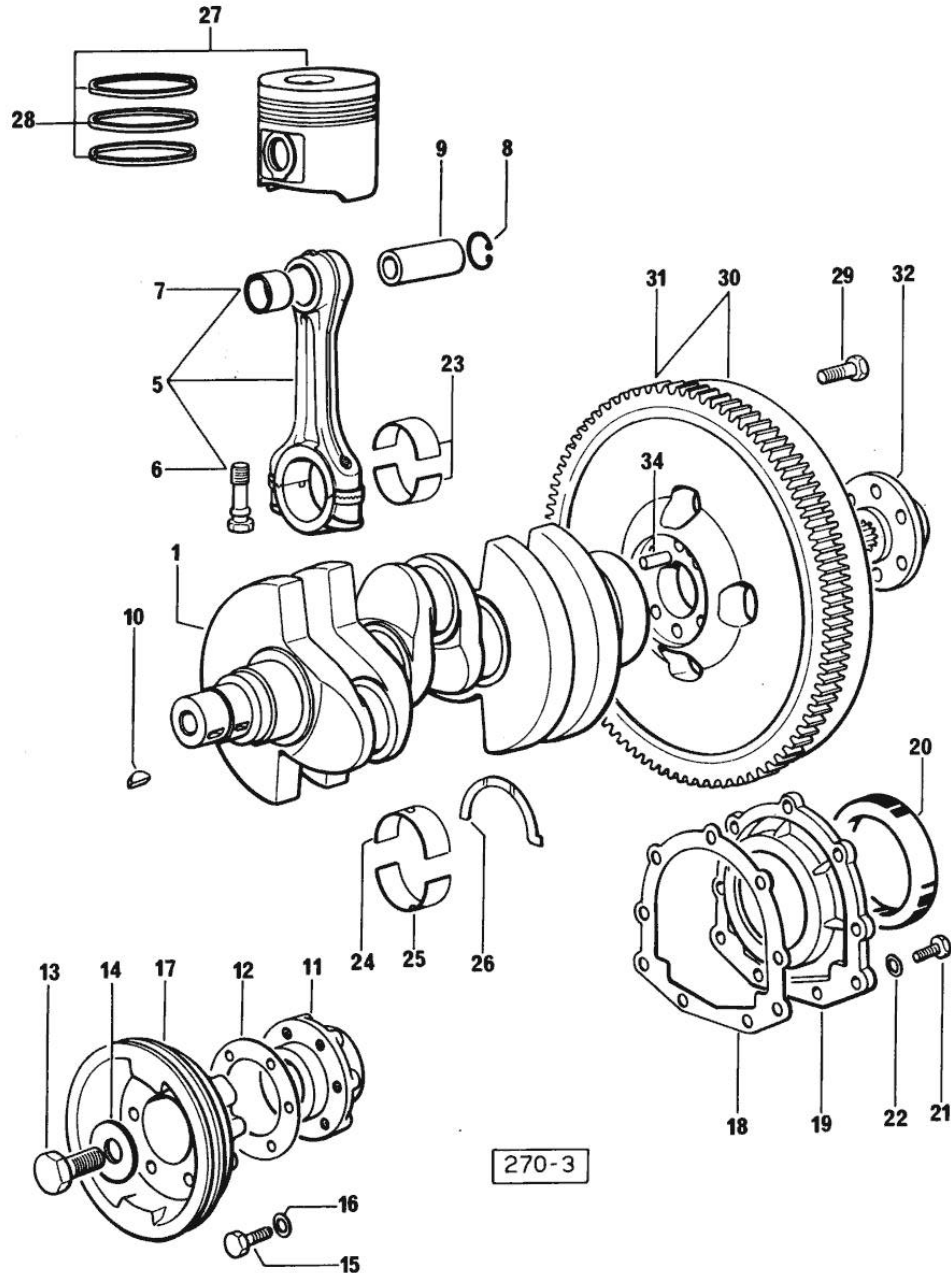

Section: ENGINE

CAMSHAFT

Fig.	P/n	QTY	Name
------	-----	-----	------

Notes:  
[EXPLORER 55]

1	0.065.1324.0	1	gear
1	0.070.1310.3	1	old part number
2	0.065.1353.0	1	small plate
3	2.0312.205.2	2	screw
4	2.1480.014.1	2	washer 8
5	065.1323.0/20	1	-
6	065.1325.3/20	1	-
6	2.1559.185.0/10	1	bushing
7	065.1351.0	2	-
8	0.065.1352.0	1	shim
9	2.1410.016.1	1	circlip 40
10	0.065.1354.0/10	1	gear z=58
11	0.065.1350.0	1	small disc
12	2.0132.207.2	4	screw m 10 p.1 x 25
13	0.065.1330.0	6	tappets
14	2.1569.114.0	12	gasket
15	2.1599.437.0	6	shoulder ring
16	2.4019.300.1	6	spring
17	0.065.1332.0	6	sleeve
18	0.065.1331.2	6	rod

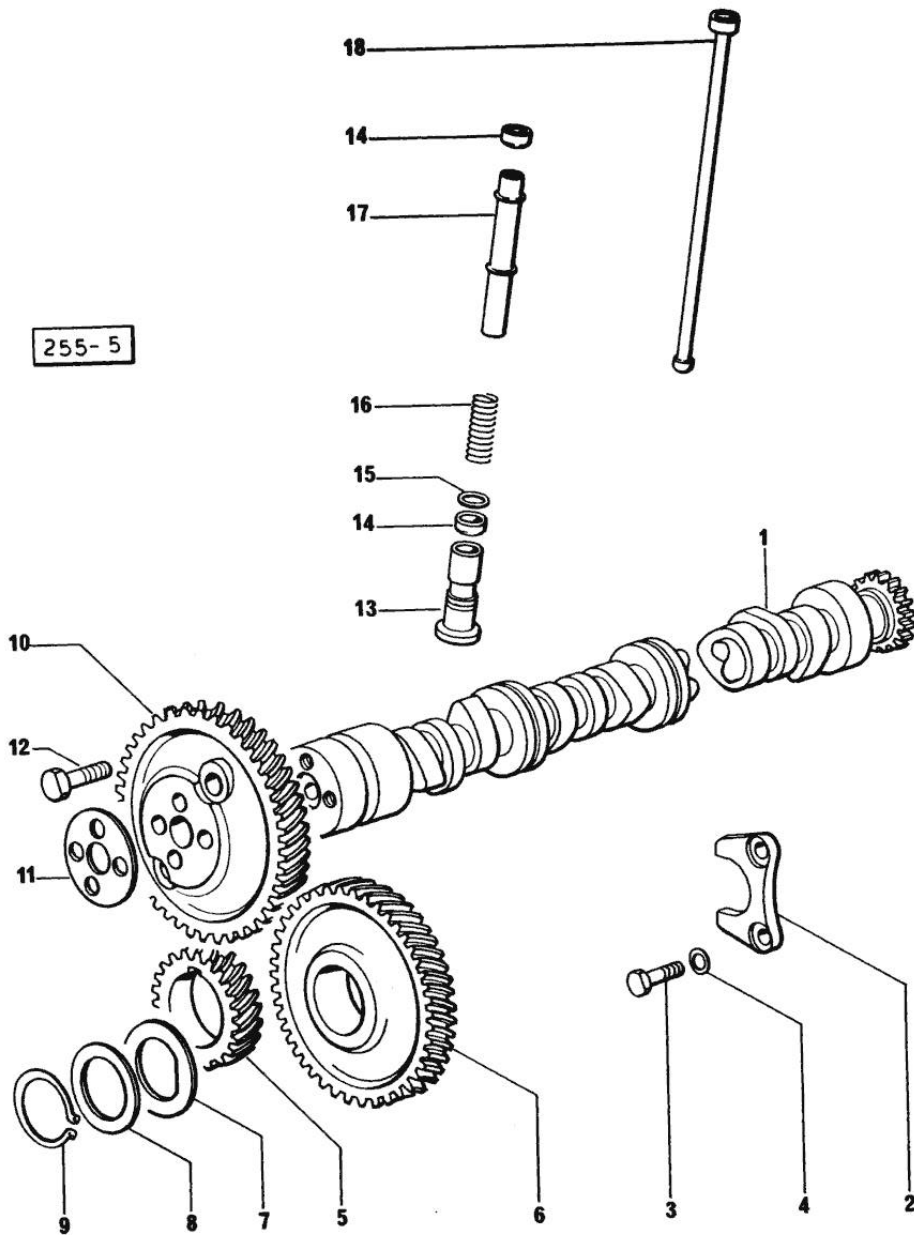

Section: ENGINE  
CYLINDER HEAD

Fig.	P/n	QTY	Name
------	-----	-----	------

Notes:  
[EXPLORER 55]

0	0.065.0057.6	1	gasket set - FOR 1 CYLINDER VALVE GRINDING AND PISTON RINGS REPLACEMEN
1	2.0112.211.2	3	screw m 8 p.1.25 x 30
2	2.1560.204.0	3	gasket
3	0.066.1440.0/10	3	small cap
4	0.069.1450.0/10	3	gasket
5	2.1011.421.2	6	nut m 10 p.1.25
6	2.0432.163.1	6	stud bolt m 10 p.1.5 / p.1.25 x 45
7	0.066.1430.0	3	support
8	0.066.1432.0	6	rocker arm
9	2.1599.432.0	6	shoulder ring
10	2.1410.055.1	6	circlip 19
11	2.1011.405.2	6	nut m 8 p.1
12	0.021.1434.0	6	screw
13	0.074.1423.0	6	conical valve cotter
14	0.066.1425.0	6	cup
15	2.4019.287.0	6	spring
16	0.065.1413.0/10	3	bush L = mm 97.1
17	2.0432.161.7	3	stud bolt m 10 p.1.5 / p.1.25 x 40
18	0.065.1443.0/10	12	screw
20	2.0432.007.1	6	stud bolt m 8 p.1.25 / p.1 x 30
21	0.085.1450.0	3	head gasket mm 0.5 -A- X 1000.3 A
21	0.085.1451.0	3	head gasket mm 0.7 -B- X 1000.3 A
21	0.085.1452.0	3	head gasket mm 1.0 -C- X 1000.3 A
21	2.1569.112.0	3	gasket X 916.3 A
22	0.066.1421.0	3	exhaust valve
23	0.066.1420.0	3	inlet valve Ø mm 9 X 916.3 A
23	0.081.1420.0	3	inlet valve Ø mm 9 X 1000.3 A
24	0.065.1410.3/10	3	engine head X 916.3 A
24	0.081.1410.3	3	engine head X 1000.3 A
25	0.066.1427.0	3	valve seat
26	0.066.1426.0	3	valve seat

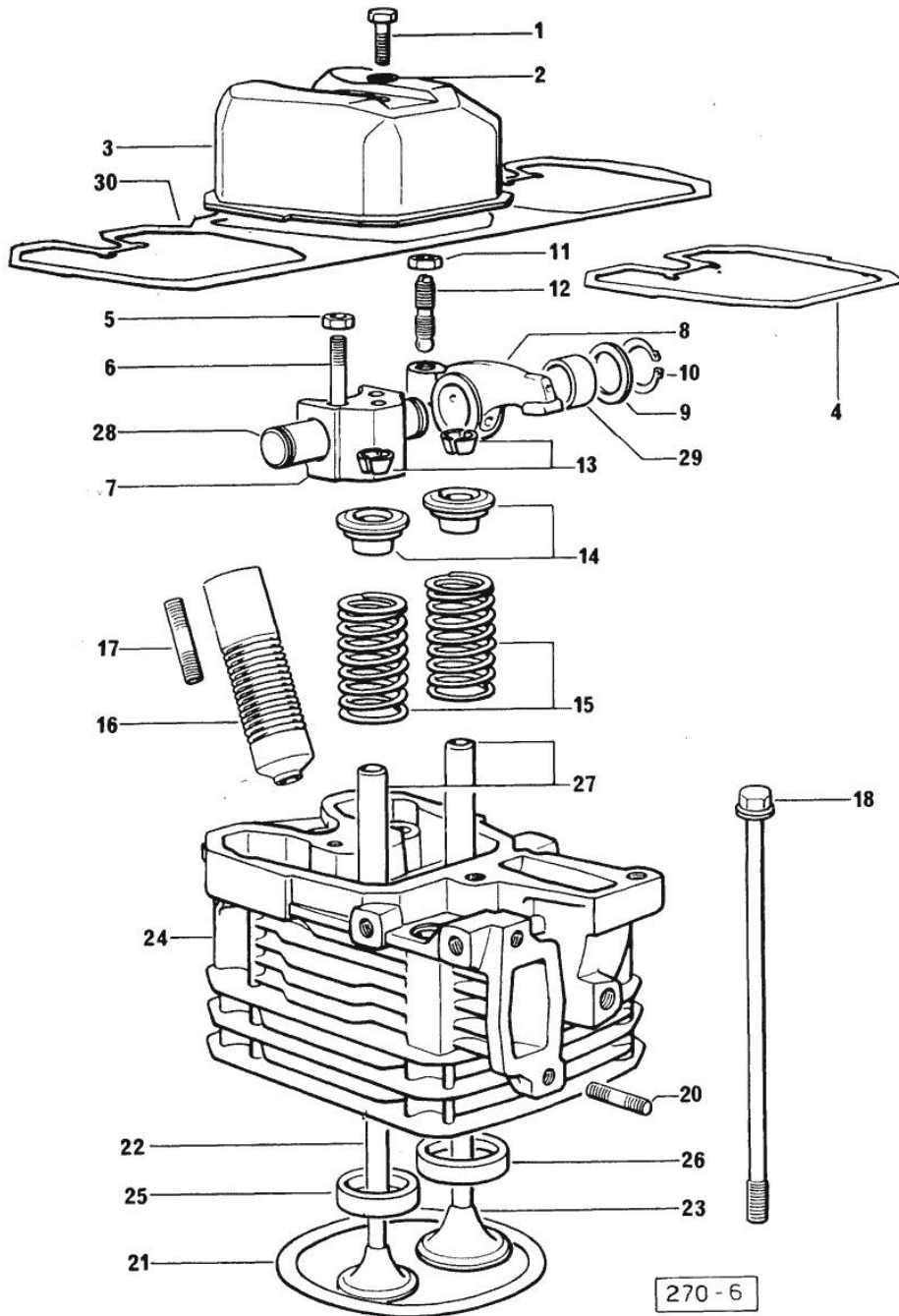

Section: ENGINE  
CYLINDER HEAD

Fig.	P/n	QTY	Name
27	0.066.1416.0	6	valve guide
28	0.066.1431.0	3	pin
29	2.1559.021.0/40	6	bushing 15x19x22
30	0.069.1450.0/10	1	gasket

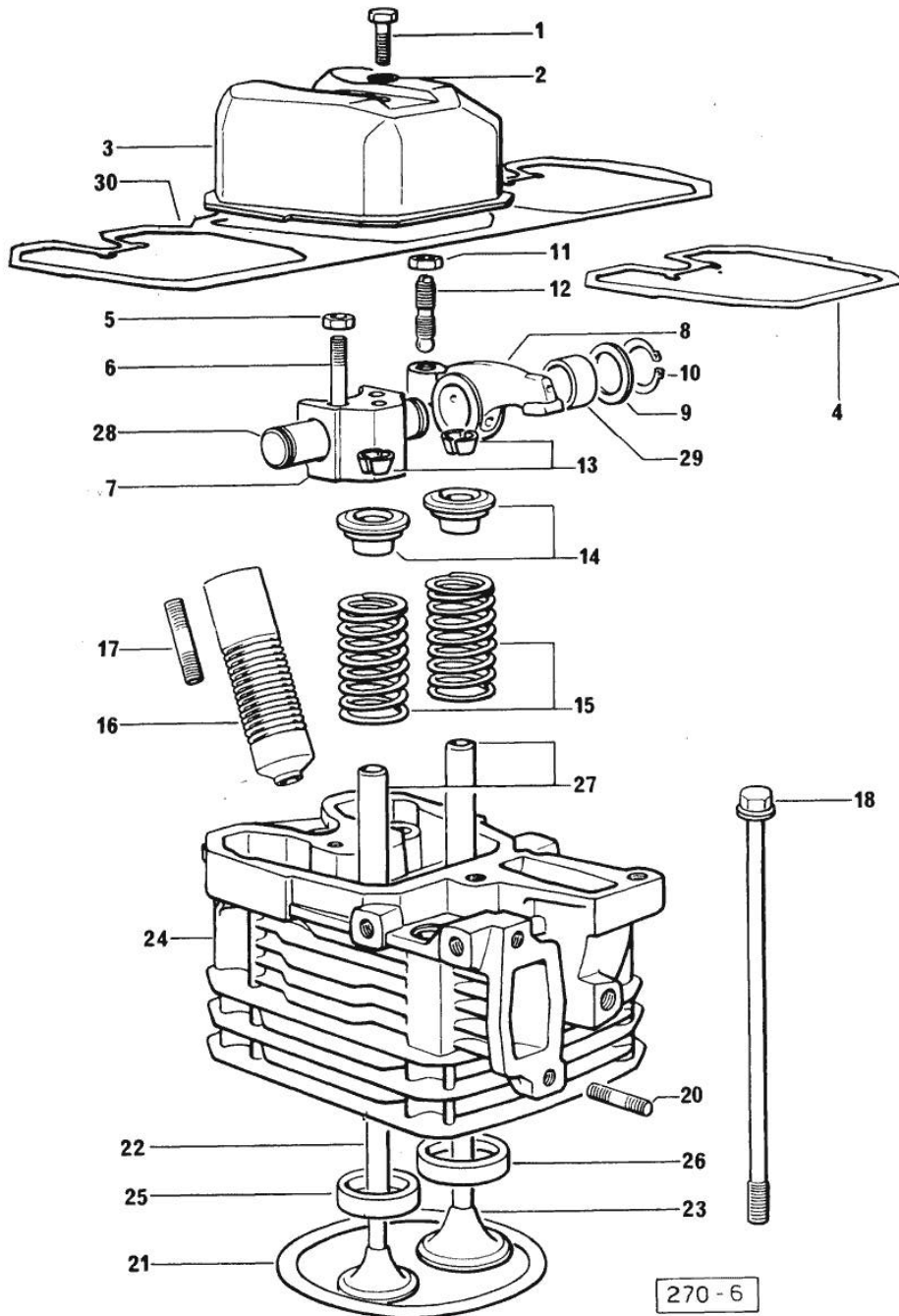

Section: ENGINE  
LUBRICATION

Fig.	P/n	QTY	Name
------	-----	-----	------

Notes:  
[EXPLORER 55]

1	0.070.1510.2/20	1	oil sump
2	0.070.1551.0	1	gasket
3	2.3199.001.2	1	plug 1/2" gas
4	2.1560.054.0	1	gasket 21 x 26
5	2.0432.003.1	22	stud bolt m 8 p.1.25 / p.1 x 20
6	2.1121.105.2	22	nut m 8 x 1
7	2.1470.004.2	22	lock washer 8
8	0.070.1531.3	1	tube
9	2.0112.205.2	1	screw m 8 p.1.25 x 16
10	2.1011.105.2	1	nut m 8 p.1.25
11	2.1470.004.2	2	lock washer 8
12	0.065.1538.0	1	flange
13	2.1539.040.0	1	special oil seal 21.82 x 3.53
14	2.0312.216.1	2	screw
15	2.1480.014.1	2	washer 8
16	0.069.1540.3/20	1	oil cooler
			X 916.3 A
16	0.085.1540.3	1	oil cooler
			X 1000.3 A
17	2.1539.048.0	2	special oil seal 20.35x1.78
18	0.069.1513.2	1	dipstick
			ORDER ALSO: 066.1551.0 2x 2.1539.065.0
18	0.085.1513.2	1	dipstick mm 78
19	2.1539.065.0	2	special oil seal 8.73 x 1.78
20	0.066.1551.0	1	spacer
21	2.3339.359.2	1	pipe fitting
22	2.1560.008.0	1	gasket 12.2 x 18
23	0.044.1567.0	1	oil filter element
24	2.3339.307.1/20	1	pipe fitting
25	0.070.1554.0	1	small plate
26	0.070.1552.0	1	small plate
27	0.070.1553.0	1	small plate
28	0.070.1555.0	1	small plate
29	2.1599.459.0	3	small plate
30	2.0399.113.2/10	2	screw
			X 916.3 A
30	2.0399.125.2	2	screw
			X 1000.3 A

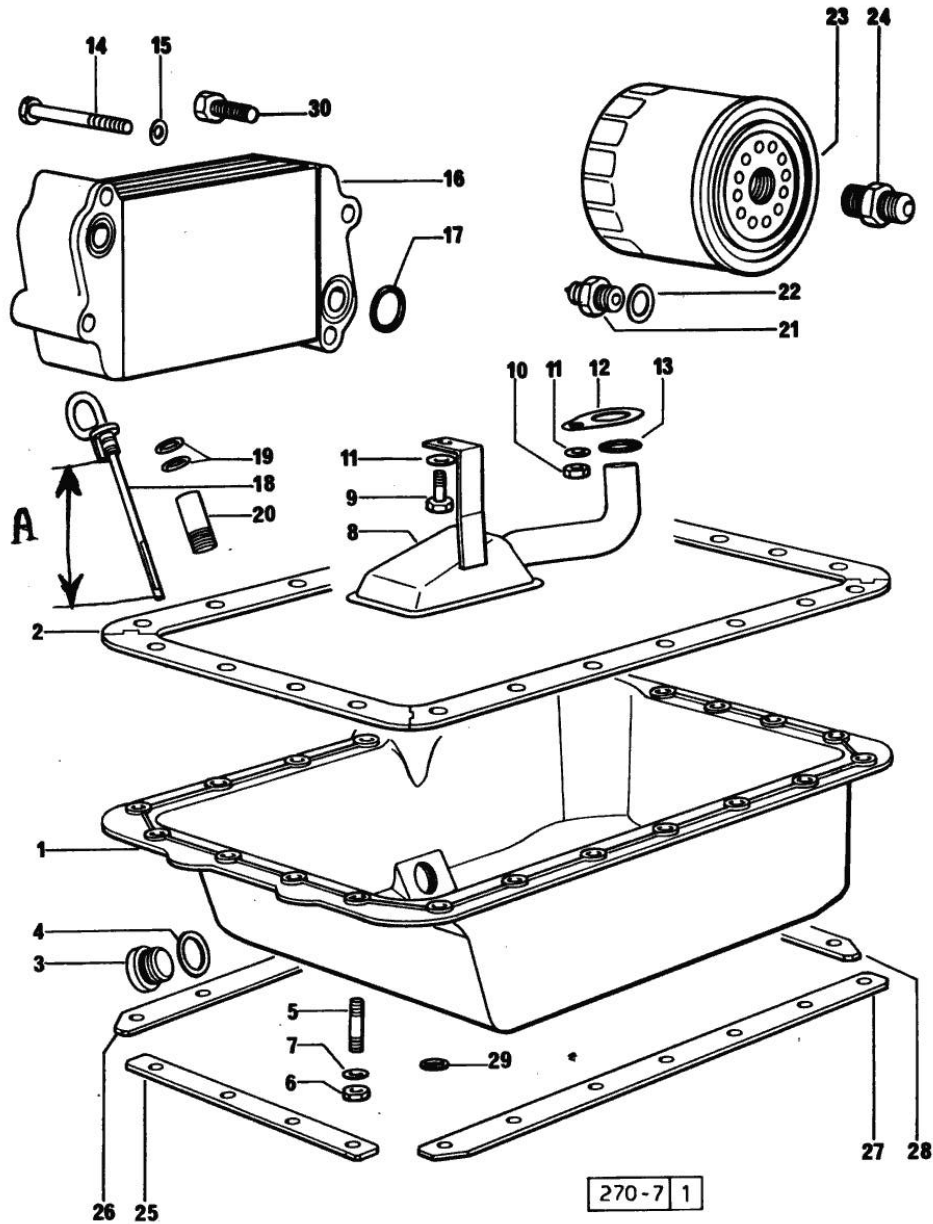



**Suggest:**

**For more complete manuals. Please go to the home page.**

**<https://www.ebooklibonline.com>**

**If the above button click is invalid. Please download this document first, and then click the above link to download the complete manual.**

**Thank you so much for reading**

Section: ENGINE  
**LUBRICATION 1349 <=**

Fig.	P/n	QTY	Name
------	-----	-----	------

Notes:  
 [EXPLORER 55]

1	2.0312.205.2	2	screw
2	2.1480.014.1	2	washer 8
3	0.041.1135.4	1	plug 1" gas
4	2.1569.072.0	1	gasket 32 x 39.5 x 2
5	0.065.1565.0/10	1	pipe union
6	0.065.1566.0	1	gasket
7	0.065.1567.0/10	1	filter
8	2.1539.042.0	1	special oil seal 47.35x1.78
9	2.1652.711.0	2	cylindrical plug 8x25
10	2.0169.005.2	2	screw m 6 p.1 x 12
11	2.1530.016.0	2	oil seal 8.73 x 1.78
12	2.0439.151.2	2	stud bolt
13	2.1470.004.2	2	lock washer 8
14	2.1011.405.2	2	nut m 8 p.1
15	2.1530.053.0	1	oil seal 20.35x1.78
16	2.1470.006.2	2	lock washer 10
17	2.0112.323.1	2	screw m 10 p.1.5x70
18	0.065.1560.0	1	old part number
19	0.065.1562.0	1	joint
20	0.065.1569.0	1	shaft
21	6.06699.42.2	1	-
22	0.066.1523.3/20	1	old part number
23	0.066.1521.3/10	1	old part number
24	0.065.1552.3/30	1	valve
25	2.1011.105.2	1	nut m 8 p.1.25
26	2.0399.119.2	1	screw
27	2.1011.103.2	1	nut m 6 p.1
28	2.1480.012.1	1	washer 6, d128
29	2.0312.116.1	1	old part number
30	2.1480.014.1	1	washer 8
31	2.1539.041.0	1	special oil seal
32	2.1410.004.1	1	circlip 16
33	0.000.0000.1	1	cannot be supplied
34	2.1589.148.0	1	shoulder ring 28.2 x 31.8 x 0.5
35	2.2020.001.0	1	ball bearing 15 x 32 x 8.00
36	2.1589.150.0	1	shoulder ring 28.2 x 31.8 x 0.1
36	2.1589.151.0	1	shoulder ring 28.2 x 31.8 x 0.15
37	2.1411.013.1	1	circlip 32
38	2.1589.146.0	1	shoulder ring 15.2 x 19 x 0.15
38	2.1589.147.0	1	shoulder ring 15.2 x 19 x 0.10
38	2.1589.153.0	1	shoulder ring 15.2 x 19 x 1.00

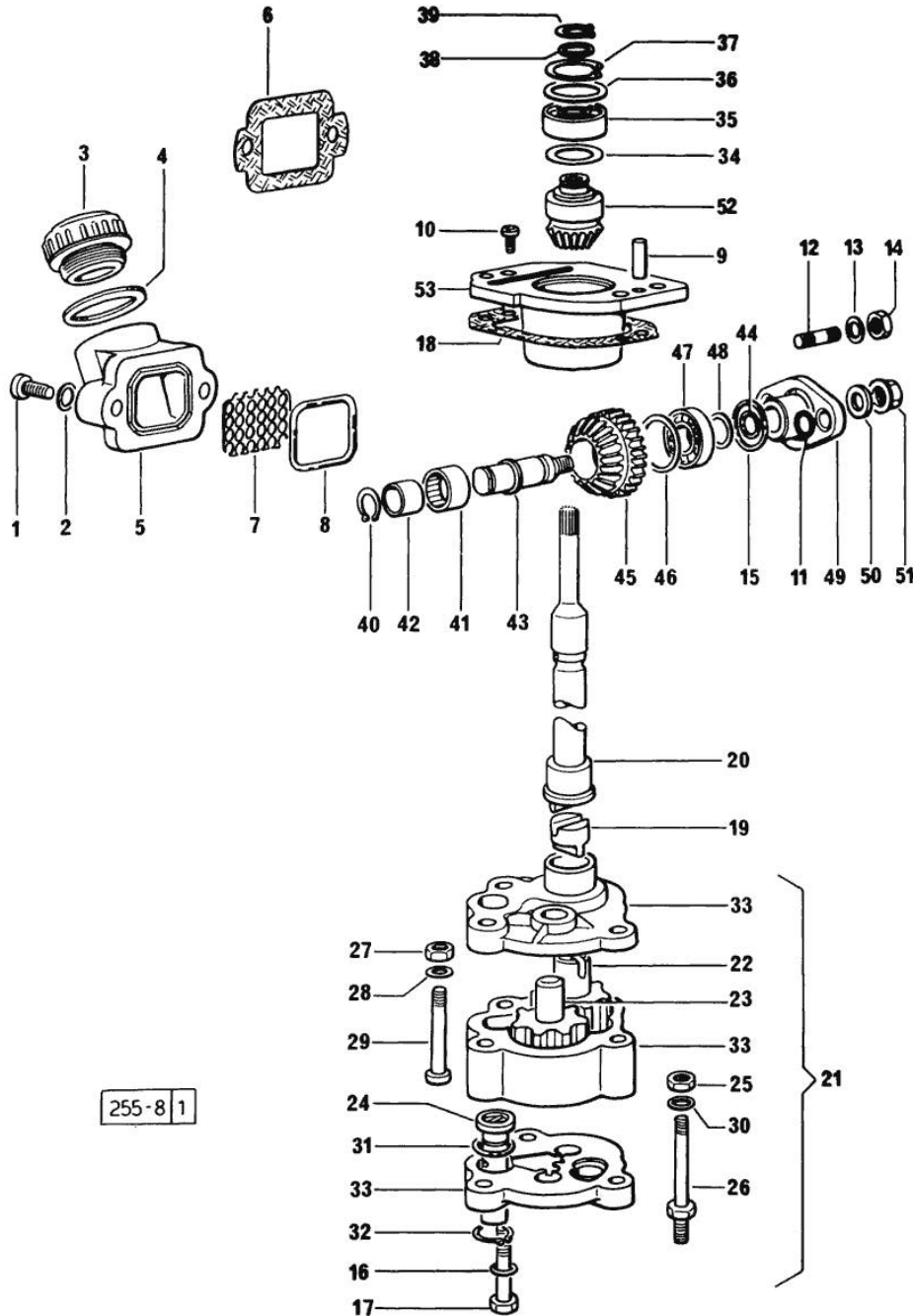

255-8 1

Section: ENGINE  
**LUBRICATION 1349 <=**

Fig.	P/n	QTY	Name
39	2.1410.057.1	1	circlip 15
40	2.1410.002.1	1	circlip 12
41	2.2725.016.0	1	roller cage 15 x 21 x 12
42	2.2680.020.0	1	ring 12 x 15 x 12
43	0.065.1564.0	1	pin
44	2.1530.016.0	1	oil seal 8.73 x 1.78
45	0.065.1561.0/10	1	old part number
46	2.1589.152.0	1	shoulder ring
47	2.2030.002.0	1	ball bearing 12 x 28 x 8
48	2.1589.143.0	1	shoulder ring mm 0.5
48	2.1589.144.0	1	shoulder ring mm 0.15
48	2.1589.145.0	1	shoulder ring mm 0.10
49	0.065.1563.0/10	1	flange
50	2.1599.477.0	1	shoulder ring
51	2.1099.094.0	1	self-locking nut
52	0.065.1558.3	1	old part number
53	0.065.1557.3	1	support

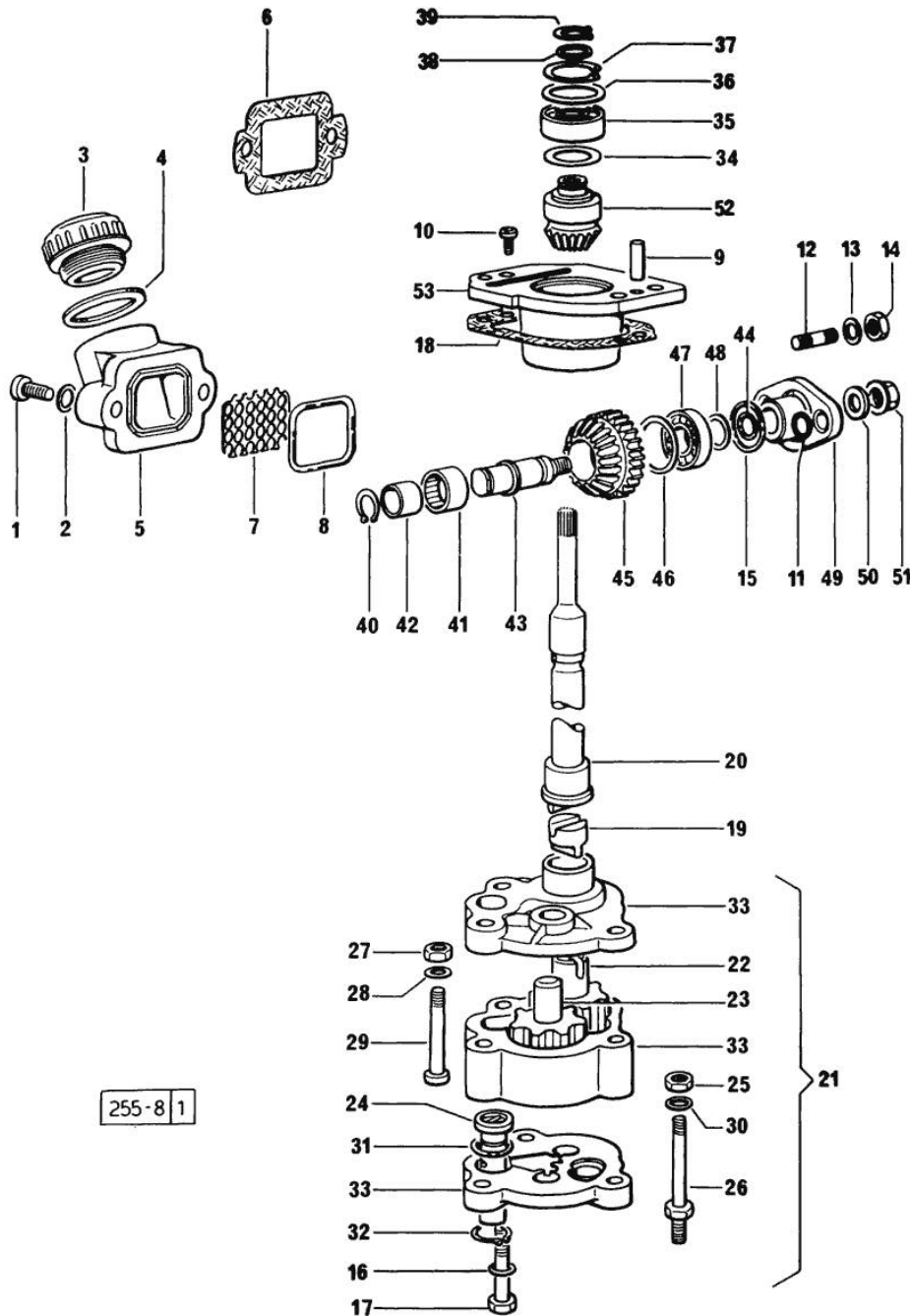

255-8 1

**<https://www.ebooklibonline.com>**

Hello dear friend!

Thank you very much for reading.

Enter the link into your browser.

The full manual is available for immediate download.

**<https://www.ebooklibonline.com>**