

Drawn Box Scraper

LL1208

LL1210

LL1212



TO THE DEALER:

Assembly and proper installation of this product is the responsibility of the Frontier dealer. Read manual instructions and safety rules. Make sure all items on the Dealer's Pre-Delivery and Delivery Check Lists in the Owner's/Operator's Manual are completed before releasing equipment to the owner.

The dealer must complete the Warranty Registration located on the Frontier website.

TO THE OWNER:

Read this manual before operating your Frontier equipment. The information presented will prepare you to do a better and safer job. Keep this manual handy for ready reference. Require all operators to read this manual carefully and become acquainted with all the adjustment and operating procedures before attempting to operate. Replacement manuals can be obtained from your Frontier dealer.

The equipment you have purchased has been carefully engineered and manufactured to provide dependable and satisfactory use. Like all mechanical products, it will require cleaning and upkeep. Lubricate the unit as specified. Observe all safety information in this manual and safety decals on the equipment.

For service, your authorized Frontier dealer has trained mechanics, genuine Frontier service parts, and the necessary tools and equipment to handle all your needs.

Use only genuine Frontier service parts. Substitute parts will void the warranty and may not meet standards required for safe and satisfactory operation. Record the model number and serial number of your equipment in the spaces provided:

Model: _____ **Date of Purchase:** _____

Serial Number: (see Safety Decal section for location) _____

Provide this information to your dealer to obtain correct repair parts.

Throughout this manual, the term **IMPORTANT** is used to indicate that failure to observe can cause damage to equipment. The terms **CAUTION, WARNING** and **DANGER** are used in conjunction with the Safety-Alert Symbol, (a triangle with an exclamation mark), to indicate the degree of hazard for items of personal safety.



This Safety-Alert Symbol indicates a hazard and means **ATTENTION! BECOME ALERT! YOUR SAFETY IS INVOLVED!**

DANGER

Indicates an imminently hazardous situation that, if not avoided, will result in death or serious injury.

 **WARNING**

Indicates a potentially hazardous situation that, if not avoided, could result in death or serious injury, and includes hazards that are exposed when guards are removed.

 **CAUTION**

Indicates a potentially hazardous situation that, if not avoided, may result in minor or moderate injury.

**IMPORTANT
NOTE**

Indicates that failure to observe can cause damage to equipment.

Indicates helpful information.

TABLE OF CONTENTS

INTRODUCTION	ii
SPECIFICATIONS / GENERAL INFORMATION	3, 4
SAFETY DECALS	5, 6
SAFETY RULES	7 - 9
DEALER INSTRUCTIONS	10
OPERATION.	11 - 15
OWNERS RESPONSIBILITY	12, 13
SET UP	12, 13
MAINTENANCE	14
LUBRICATION	14
HYDRAULICS AND OPTIONAL EQUIPMENT	15
PARTS CATALOG	16 - 18
BOLT AND BOLT TORQUE CHART.	19

GENERAL INFORMATION

The purpose of this manual is to assist you in operating and maintaining your drawn box scraper. Read it carefully. It furnishes information and instructions that will help you achieve years of dependable performance.

These instructions have been compiled from field experience and engineering data. Some information may be general in nature, due to unknown and varying operating conditions. However, through experience and these instructions, you should be able to develop procedures suitable to

your particular situation.

The illustrations and data used in this manual were current at the time of printing. However, due to possible inline production changes, your machine may vary slightly in detail. We reserve the right to redesign and change the machines as may be necessary without notification.

Throughout this manual, references are made to right and left direction. These are determined by standing behind the tractor facing the direction of forward travel.

<https://www.ebooklibonline.com>

Hello dear friend!

Thank you very much for reading.

Enter the link into your browser.

The full manual is available for immediate download.

<https://www.ebooklibonline.com>

LL12 SERIES BASE UNIT SPECIFICATIONS

Model	LL1208	LL1210	LL1212
Tractor HP	35-100	35-125	35-125
Working Width	8 Feet	10 Feet	12 Feet
Machine Width	8 Feet 1/4 Inches	10 Feet 1/4 Inches	11 Feet 11 Inches
Machine Length	12 Feet	12 Feet	12 Feet
Machine Height	36 Inches	36 Inches	36 Inches
Operating Weight	1550 lbs	1650 lbs.	1750 lbs
Hitch Type	Drawn	Drawn	Drawn
Cutting Edge	6 Inches Tall, 5/8 Thick Grading Blade	6 Inches Tall, 5/8 Thick Grading Blade	6 Inches Tall, 5/8 Thick Grading Blade
Moldboard Thickness	1/4 Inch	1/4 Inch	1/4 Inch
End Plate Thickness	3/8 Inch	3/8 Inch	3/8 Inch
Hydraulic Cylinders	Standard	Standard	Standard
Hydraulic Cylinders (#)	1	1	1
Cylinder Size	3 Inches	3 Inches	3 Inches
Cylinder Rod Size	1 3/8 Inches	1 3/8 Inches	1 3/8 Inches
Cylinder Stroke Length	8 Inches	8 Inches	8 Inches
Safety Chains	Standard	Standard	Standard
Duty	Standard	Standard	Standard

LL12 SERIES OPTIONAL EQUIPMENT SPECIFICATIONS

Model	LL1208	LL1210	LL1212
Hydraulic Tilt	Optional Attachment	Optional Attachment	Optional Attachment
Hydraulic Cylinders (#)	1	1	1
Cylinder Size	3 Inches	3 Inches	3 Inches
Cylinder Rod Size	1 3/8 Inches	1 3/8 Inches	1 3/8 Inches
Cylinder Stroke Length	8 inches	8 Inches	8 Inches

SAFETY & INSTRUCTIONAL DECALS, REFLECTORS AND LIGHTS
ATTENTION! BECOME ALERT! YOUR SAFETY IS INVOLVED!
FAILURE TO FOLLOW THESE INSTRUCTIONS COULD RESULT IN SERIOUS INJURY OR DEATH

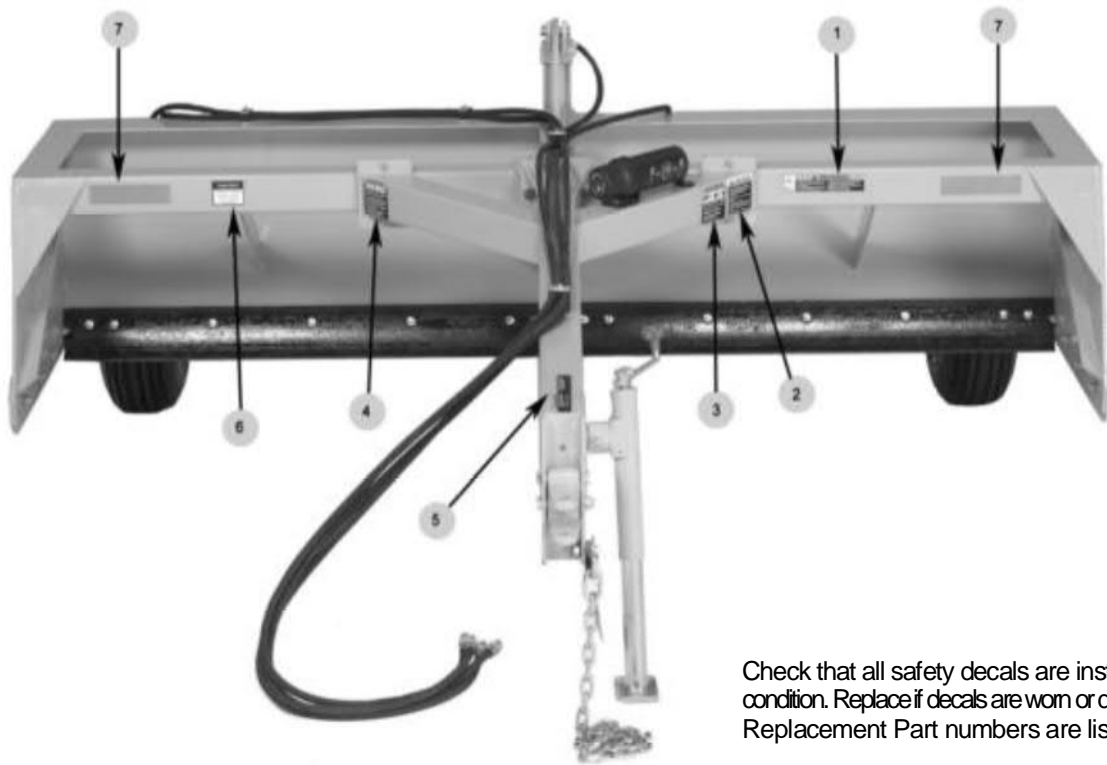

Check that all safety decals are installed and in good condition. Replace if decals are worn or damaged. Replacement Part numbers are listed on Page 6.

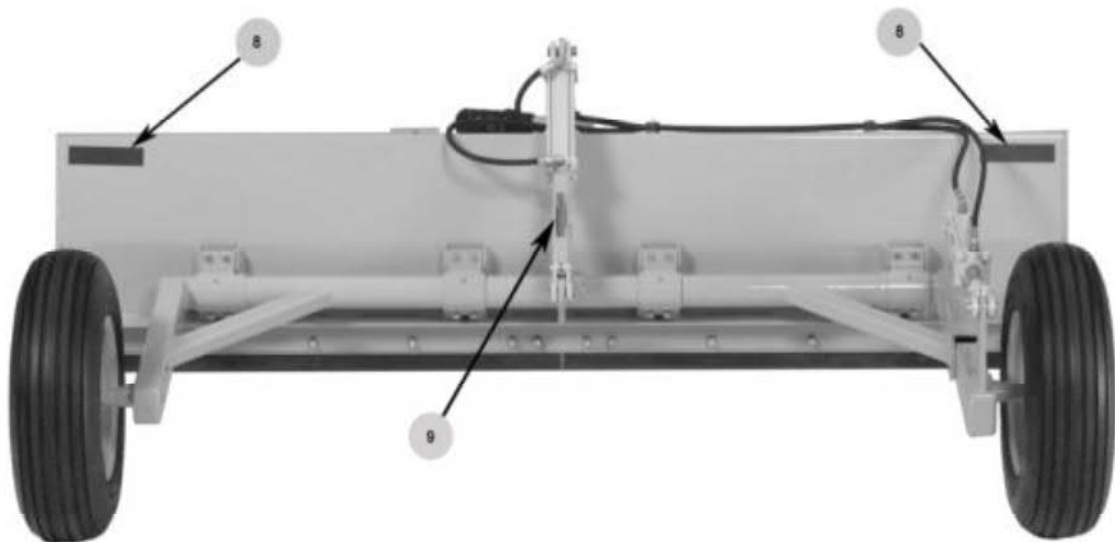

5 Safety Decals

SAFETY & INSTRUCTIONAL DECALS, REFLECTORS AND LIGHTS

ATTENTION! BECOME ALERT! YOUR SAFETY IS INVOLVED!

FAILURE TO FOLLOW THESE INSTRUCTIONS COULD RESULT IN SERIOUS INJURY OR DEATH

Check that all safety decals are installed and in good condition. Replace if decals are worn or damaged. Replacement Part numbers are listed here.

DECAL SHEET INCLUDES:
 DECALS 1,2,3,4,5,6,9 (2) FRONTIER
 DECALS, (2) LL12 SERIES DECALS FOR
 EACH SPECIFIC MODEL

DECAL SHEET PART NUMBERS FOR EACH

MODEL: 5DDP00537 LL1208
 5DDP00526 LL1210
 5DDP00536 LL1212



1



2



3



4

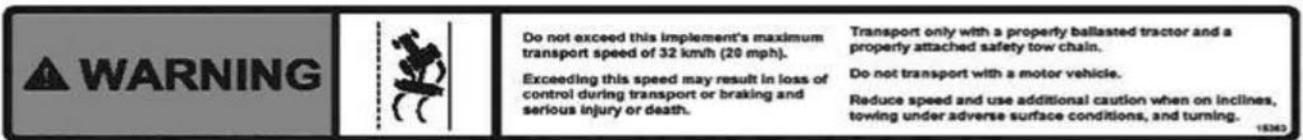

5



6

5DDP00205
 Frontier
 Serial Number

10



7

5DDP00163
 2" x 9" Yellow Reflective Strips

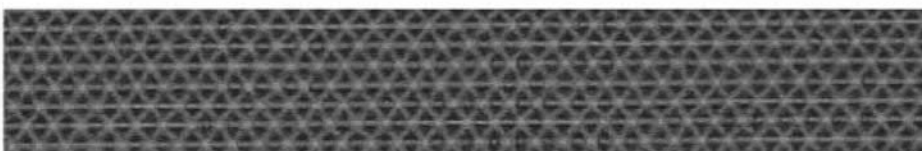

8

5DDP00162
 2" x 9" Red Reflective Strips



9

6 Safety Rules



SAFETY RULES



ATTENTION! BECOME ALERT! YOUR SAFETY IS INVOLVED!

Safety is a primary concern in the design and manufacture of our products. Unfortunately, our efforts to provide safe equipment can be wiped out by an operator's single careless act.

In addition to the design and configuration of equipment, hazard control and accident prevention are dependent upon the awareness, concern, judgment, and proper training of personnel involved in the operation, transport, maintenance and storage of equipment.

It has been said "The best safety device is an informed, careful operator." We ask you to be that kind of operator.

TRAINING

- Safety instructions are important! Read all attachment and power unit manuals; follow all safety rules and safety decal information. (Replacement manuals are available from selling dealer.) Failure to follow instructions or safety rules can result in serious injury or death.
- If you do not understand any part of this manual and need assistance, see your dealer.
- Operators must be instructed in and be capable of the safe operation of the equipment, its attachments, and all controls. Do not allow anyone to operate this equipment without proper instructions.
- Never allow children or untrained persons to operate equipment.
- Train all new personnel and review instruction's frequently with existing workers. A person who has not read and understood all operating and safety instructions is not qualified to operate the machine. An untrained operator exposes himself and bystanders to possible serious injury or death.

PREPARATION

- Always wear relatively tight and belted clothing to

avoid getting caught in moving parts. Wear sturdy, rough-soled work shoes and protective equipment for eyes, hair, hands, hearing, and head; and respirator or filter mask where appropriate.

- Make sure equipment is properly secured, adjusted, and in good operating condition.
- Power unit must be equipped with ROPS or ROPS cab and seat belt. Keep seat belt securely fastened. Falling off power unit can result in death from being run over or crushed. Keep foldable ROPS system in "locked up" position at all times.
- A minimum 20% of tractor and equipment weight must be on the tractor front wheels when attachments are in transport position. Without this weight, the tractor could tip over, causing personal injury or death. The weight may be attained with a loader, front wheel weights, ballast in tires or front tractor weights. Weigh the tractor and equipment. Do not estimate.

TRANSPORTATION

- Always comply with all state and local laws governing highway safety and lighting and marking requirements.
- Keep away from overhead power lines. Serious injury or death may result. Know the transport height and width of your machine.
- Never allow riders on power unit or attachment.
- Do not operate or transport on steep slopes.
- Use extreme care and reduce ground speed on slopes and rough terrain.
- Prevent collisions between other road users, slow moving tractors with attachments or towed equipment, and self-propelled machines on public roads. Frequently check for traffic from the rear, especially in turns, and use turn signal lights

7 Safety Rules



SAFETY RULES



ATTENTION! BECOME ALERT! YOUR SAFETY IS INVOLVED!

- Do not operate or transport equipment while under the influence of alcohol or drugs. Consult your doctor about operating this machine while taking prescription medications.

OPERATION

- Never go underneath equipment (lowered to the ground or raised) unless it is properly blocked and secured.

- Never place any part of the body underneath equipment or between moveable parts even when the engine has been turned off. Hydraulic system leak down, hydraulic system failures, mechanical failures, or movement of control levers can cause equipment to drop or rotate unexpectedly and cause severe injury or death.

- Escaping fluid under pressure can penetrate the skin causing serious injury. Avoid the hazard by relieving pressure before disconnecting hydraulic or other lines. Tighten all connections before applying pressure. Search for leaks with a piece of cardboard.

- Protect hands and body from high pressure fluids. If an accident occurs, see a doctor immediately. Any fluid injected into the skin must be surgically removed within a few hours or gangrene may result. Doctors unfamiliar with this type of injury should reference a knowledgeable medical source.

- Always comply with all state and local laws governing highway safety and lighting and marking requirements.

- Operate only in daylight or good artificial light.

- Keep bystanders away from equipment.

- Keep hands, feet, hair, and clothing away from equipment while engine is running. Stay clear of all moving parts.

- Power unit must be equipped with ROPS or ROPS cab and seat belt. Keep seat belt securely fastened. Falling off power unit can result in death from being run over or crushed. Keep foldable ROPS system in “locked up” position at all times.

- Never allow riders on power unit or attachment.

- Always sit in power unit seat when operating controls or starting engine. Securely fasten seat belt, place transmission in neutral, engage brake, and ensure all other controls are disengaged before starting power unit engine.

- Look down and to the rear and make sure area is clear before operating in reverse.

- Use extreme care when working close to fences, ditches, other obstructions, or on hillsides.

- Do not operate or transport on steep slopes.

- Do not stop, start, or change directions suddenly on slopes. Always operate down slopes; never across the face.

- Use extreme care and reduce ground speed on slopes and rough terrain.

- Keep alert and watch the front, as well as, the rear when operating.

- Be careful to keep hands and feet clear of sliding parts and possible pinch points.

- Stop power unit and equipment immediately upon striking an obstruction. Engage brake, turn off engine, remove key, inspect, and repair any damage before resuming operation.

- Before leaving operator’s seat, put equipment on the ground. Engage brake, stop engine, remove key, and remove seat belt.

8 Safety Rules



SAFETY RULES



ATTENTION! BECOME ALERT! YOUR SAFETY IS INVOLVED!

MAINTENANCE

- Always wear relatively tight and belted clothing to avoid getting caught in moving parts. Wear sturdy, rough-soled work shoes and protective equipment for eyes, hair, hands, hearing, and head; and respirator or filter mask where appropriate.
- Never go underneath equipment (lowered to the ground or raised) unless it is properly blocked and secured. Never place any part of the body underneath equipment or between moveable parts even when the engine has been turned off. Hydraulic system leak down, hydraulic system failures, mechanical failures, or movement of control levers can cause equipment to drop or rotate unexpectedly and cause severe injury or death.
- When performing maintenance or repairs make sure the equipment is in the lowered position and properly blocked and secured to prevent rolling. Failure to do so can cause serious injury or death.
- Make sure equipment is properly secured, adjusted, and in good operating condition.
- Before leaving operator's seat, put equipment on the ground. Engage brake, stop engine, remove key, and remove seat belt.
- Never perform service or maintenance with engine running.
- Keep all persons away from operator control area while performing adjustments, service, or maintenance.
- Use tools appropriate to the work. Makeshift tools and procedures can create safety hazards.
- Use power tools only to loosen threaded parts and fasteners.

- For loosening and tightening hardware, use the correct size tools. DO NOT use U.S. measurement tools on metric fasteners or vice versa. Avoid bodily injury caused by slipping wrenches.
- Tighten all bolts, nuts, and screws to torque chart specifications (See Bolt and Torque chart on page 32). Check that all cotter pins are installed securely to ensure equipment is in a safe condition before putting unit into service.
- Explosive separation of a tire and rim parts can cause serious injury or death.
- Do not attempt to mount a tire unless you have the proper equipment and experience to perform the job.
- Always maintain the correct tire pressure. Do not inflate the tires above the recommended pressure. Never weld or heat a wheel and tire assembly. The heat can cause an increase in air pressure resulting in a tire explosion. Welding can structurally weaken or deform the wheel.
- When inflating tires, use a clip-on chuck and extension hose long enough to allow you to stand to one side and NOT in front of or over the tire assembly. Use a safety cage if available.
- Check wheels for low pressure, cuts, bubbles, damaged rims or missing lug bolts and nuts. Replace if necessary.

STORAGE

- Block equipment securely for storage.
- Keep children and bystanders away from storage area.

9 Safety Rules

DEALER INSTRUCTIONS

Dealer's Responsibility

Dealer Checklist

Inspect the equipment thoroughly after assembly to be certain it is set up properly before delivering it to the customer. The following check list is a reminder of points to inspect. Check off each item if it is found satisfactory or after proper adjustment is made.

____ Check that all safety decals are installed and in good condition. Replace if damaged.

____ Check all bolts to be sure they are tight and torqued to proper specifications as per the Bolt and Torque Chart on page 32.

____ Check that all cotter pins and safety pins are properly installed.

____ It is important for the dealer to visually check and make sure all parts are in tact prior to delivery to customer.

____ Show customer the safe, proper procedures to be used when mounting, dismounting, and storing equipment.

____ Show customer how to make adjustments.

____ Present Operator's Manual and request that customer and all operators read it before operating equipment. Point out the manual safety rules, explain their meanings and emphasize the increased safety hazards that exist when safety rules are not followed.

____ Point out the safety decals. Explain their meaning and the need to keep them in place and in good condition. Emphasize the increased safety hazards when instructions are not followed.

____ Explain to customer the potential crushing hazards of going underneath raised equipment. Instruct customer that service work does not require going underneath unit and never to do so.

____ Complete the Warranty Registration located on the Frontier website.

Operation

Safety is a primary concern in the design and manufacture of our products. Unfortunately, our efforts to provide safe equipment can be wiped out by an operator's single careless act.

In addition to the design and configuration of equipment, hazard control and accident prevention are dependent upon the awareness, concern, judgment, and proper training of personnel involved in the operation, transport, maintenance, and storage of equipment.

It has been said "The best safety device is an informed, careful operator." We ask you to be that kind of operator.

The operator is responsible for the safe operation of this equipment. The operator must be properly trained. Operators should be familiar with the equipment, the tractor, and all safety practices before starting operation. Read the safety rules and safety decals on pages 3-7.

Owner should check and tighten all hardware after the first hour of operation. The break in stage of your new drawn box scraper can cause minimal loosening of hardware. Please see Bolt Torque Chart (Page 32) for proper torque information.

WARNING

- Before starting engine sound horn on the power unit twice to warn people in the vicinity that operation is about to begin.
- Power unit must be equipped with ROPS or ROPS cab and seat belt. Keep seat belt securely fastened. Falling off power unit can result in death from being run over or crushed. Keep foldable ROPS systems in "locked up" position at all times.
- Never allow children or untrained persons to operate equipment.

- Keep bystanders away from equipment.
- **NEVER GO UNDERNEATH EQUIPMENT.** Never place any part of the body underneath equipment or between moveable parts even when the engine has been turned off. Hydraulic system leak down, hydraulic system failures, mechanical failures, or movement of control levers can cause equipment to drop or rotate unexpectedly and cause severe injury or death.
- Service work does not require going underneath.
- Read Operator's Manual for service instructions or have service performed by a qualified dealer.
- Stop power unit and implement immediately upon striking an obstruction. Engage brake, turn off engine, remove key, inspect, and repair any damage before resuming operation.
- Always wear relatively tight and belted clothing to avoid entanglement in moving parts. Wear sturdy, rough-soled work shoes and protective equipment for eyes, hair, hands, hearing, and head.

Owner/Operator Pre-Operation Checklist (Owner's/Operator's Responsibility)

- ___ Review and follow all safety rules and safety decal instructions on page 3 through page 7.
- ___ Check that equipment is properly and securely attached to tractor.
- ___ Check that all safety decals are installed and in good condition. Replace if damaged.
- ___ Check that all hardware is properly installed and secured.
- ___ Do not allow riders.
- ___ Make sure tractor ROPS or ROPS CAB and seat belt are in good condition. Keep seat belt securely fastened during operation.

Owner's Responsibility

Always use safety chains when transporting. Provide only enough slack in the chain to allow turning.

WARNING

Always use the transport cylinder locks to hold the scraper in the raised position when transporting (Page 12, Ref. Fig. 2, 3).

Check wheel lug nuts on scraper before and after transporting.

Do not transport scraper in excess of 20 mph. Slow down when turning and transporting over rough ground or the scraper may tip over. Travel at a reasonable and safe speed.

Never remove locking pins until hydraulic cylinders and lines are full of fluid and free of air.

Stand clear when raising or lowering the scraper. Beware of pinching hazards especially at the cutter bar, side panels and wheel assembly of scraper.

Never stand with feet under soil penetrating cutter bars and side panel areas. Always use blocking to prevent movement of scraper when maintaining or repairing scraper.

WARNING

Never lubricate, adjust, service or adjust scraper when moving.

Never modify this scraper without conferring first with the equipment representative.

Always store with the cutter bar in the down, at rest, position.

Beware of overhead wires and narrow gates. Be aware of the scraper's length, height and width.

Always use safety lockups when servicing or repairing scraper. Shut off tractor and remove the key before servicing or repairing scraper.

Do not operate close to a body of water.

Always shift to park, set brakes and shut off the tractor when dismantling the tractor.

Always maintain the correct tire pressure. Do not over inflate tires.

Inspect tires and wheels daily. Do not operate with low tire pressure, cuts, bubbles, damaged rims, or missing or loose lug bolts and nuts.

Carefully inspect tire and rim assembly after a flat or under inflated tire for damage to the rim or tire.

Use a clip on chuck and extension hose long enough to stand clear and to the side of the wheel assembly when inflating tires.

Never cut or weld near an inflated tire or rim assembly. Heat may cause an increase in pressure that may cause the tire to explode.

Do not attempt to mount a tire without proper equipment and experience to complete the job.

Hydraulic System

Always relieve pressure before disconnecting hydraulic and other lines. Avoid high pressure fluids. Escaping fluid under pressure can penetrate the skin causing serious injury.

WARNING

Search for leaks with a piece of cardboard. Protect hands and body from high pressure fluids. If an accident occurs, see a doctor immediately. Any fluid injected into the skin must be removed within a few hours.

Avoid using heat near pressurized fluid lines. Heating can generate flammable spray, resulting in severe burns.

Hydraulic hoses can fail due to physical damage, kinks, age and exposure. Check hoses regularly. Replace damaged or worn hoses immediately. All hydraulic couplers must be clear of dirt and debris. Use protective caps on all fluid openings. Foreign debris can damage the hydraulic system.

Check that the tractor's hydraulic fluid level is full. Run drawn box scraper through several complete cycles from full cut to full dump to remove any trapped air from hydraulic hoses and cylinders. Recheck tractor's hydraulic fluid level and refill with the scraper in the fully raised position as needed.

12 Operations

Owner's Responsibility(cont'd)

Clean up any spilled fluid immediately to prevent accidents and/or environmental damage.

Use leak proof containers when draining fluid. Do not use food and beverage containers that may mislead someone into drinking it. Dispose of fluids properly.

Set Up

The LL12 Series Drawn Box Scraper should be matched to a tractor with sufficient horsepower to pull the implement without stalling or overloading the tractors engine.

IMPORTANT: Tractor horsepower recommendations for the LL12 can be found in the Specifications (Page 1) section of this manual.

This procedure should be done on a level surface, preferably concrete with equal air pressure in all tires. Set the LL12 Series Drawn Box Scraper on the level surface with the blade lightly touching the floor. Place jack in upright position and disengage the leveler from the tractor. Place a level on the top flat part of the leveler where indicated (Figure 1) and use the jack to level the machine. After leveling, back your tractor to the hook up position and adjust the hitch to the nearest hole that will match up to the tractor draw bar.

NOTE: This procedure must be completed every time a different tractor is used. The LL12 Series Drawn Box Scraper is designed to operate level in the lowered position.

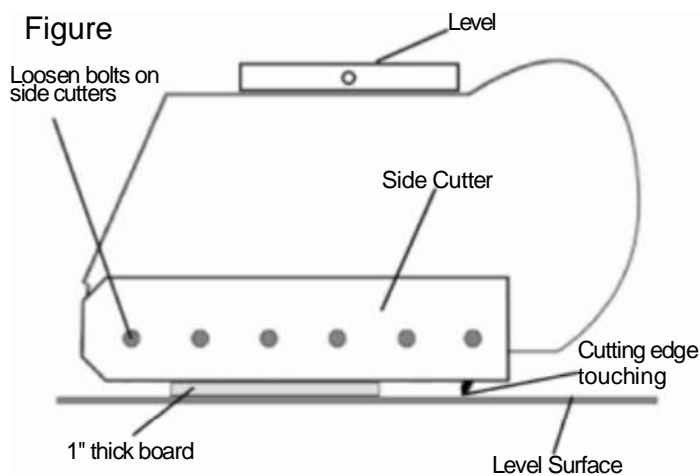

WARNING

To help prevent serious injury or death to you or others caused by unexpected movement, be sure to perform these adjustments on a level surface. If machine is connected to tractor, engage parking brake and place transmission in PARK. Raise the land leveler and slide the transport cylinder lock over the hydraulic cylinder rod (Page 12, Figure 4 and 5). Insert and lock the transport lock snapper pin(Page 12, Figure 5).

The side cutters on the outside of the leveler should be set level with the floor when attached to the tractor. The side cutters are set at the factory at approximately 1" from the bottom of the cutting edge. As a rule of thumb this works for most applications. You may want to adjust the side cutters higher or lower according to soil conditions and scraper application. Set the LL12 Series Drawn Box Scraper on the level surface with the blade lightly touching the floor. Loosen the bolts holding the side cutting edge and adjust height being careful to keep the side cutters level with the ground surface. Retighten the bolts holding the side cutter edge to the leveler.

Inspect side cutter blade edges periodically for wear and damage. When damage or wear exists switch the blade to its reversible cutting edge by loosening and removing the carriage bolts securing the blade to the moldboard end plate. Flip the blade and reinsert the carriage bolts, washers and tighten the nuts(Refer to the Bolt and Torque Chart on Page 32).

NOTE: It is important this procedure be done or you may experience excessive and unnecessary wear on the side cutters.

Side cutters are designed to contain debris. If the side cutters are showing uneven wear they are not set correctly

NOTE: Tighten adjustment bolt according to the Bolt and Torque Chart on Page 32.

The LL12 Series Drawn Box Scraper is designed to operate smoothly at 6-8 mph. When maintaining or grading roads it is recommended the

13 Operations

scraper be operated 1/3 to 1/2 full. This will allow the scraper to cut and take on material when cutting while allowing the scraper to fill when needed. Filling the scraper only burns excess fuel and increases tire wear. When starting out, operate the scraper slower to allow material to accumulate then progress to 6-8 mph.

Do not operate the drawn box scraper in rocky conditions. Doing so may cause damage to the drawn box scraper.

Do not make turns with the scraper engaged. Doing so may cause damage to the drawn box scraper.

Maintenance

It is important to maintain and service the LL12 Series Drawn Box Scraper to continually do the work it was designed for.

WARNING

To help prevent serious injury or death to you or others caused by unexpected movement, be sure to service machine on a level surface. If machine is connected to tractor, engage parking brake and place transmission in PARK. Shut off engine and remove key. If machine is detached from tractor block wheels and use safety stands to prevent movement.

Inspect side cutting edges periodically for wear and damage. Replace when necessary.

Maintain equal air pressure in all tires to prevent uneven cutting.

Check wheels for low pressure, cuts, bubbles, damaged rims or missing lug bolts and nuts. Replace as necessary.

Explosive separation of a tire and rim parts can cause serious injury or death. Do not attempt to mount a tire unless you have the proper equipment and experience to perform the job.

Always maintain the correct tire pressure. Do not inflate the tires above the recommended pressure.

Never weld or heat a wheel and tire assembly. The heat can cause an increase in air pressure resulting in a tire explosion. Welding can structurally weaken or deform the wheel.

When inflating tires, use a clip-on chuck and extension hose long enough to allow you to stand to one side and NOT in front of or over the tire assembly.

Lubrication

WARNING

It is important to maintain and service the LL12 Series Drawn Box Scraper to continually do the work it was designed for.

LL12 Series Drawn Box Scraper

Grease the scraper and optional equipment at the following locations and intervals:

Rear axle connections to the moldboard – grease daily or every 10 hours.

Hub Assembly – grease every 50 hours.

14 Operations

Hydraulics

It is important to keep hydraulics well maintained to prevent strain on the scraper or the tractor.

Check fluids regularly and keep reservoirs filled to proper capacity.

Escaping fluid under pressure can penetrate the skin causing serious injury. Avoid the hazard by relieving pressure before disconnecting hydraulic or other lines. Tighten all connections before applying pressure.

Search for leaks with a piece of cardboard. Protect hands and body from high pressure fluids. Spray from high pressure nozzles can penetrate the skin and cause serious injury. Keep spray from contacting hands or body. If an accident occurs, see a doctor immediately. Any fluid injected into the skin must be surgically removed within a few hours or gangrene may result. Doctors unfamiliar with this type of injury should reference a knowledgeable medical source.

Hydraulic hoses can fail due to physical damage, kinks, age, and exposure. Check hoses regularly, replace damaged hoses.

IMPORTANT: All hydraulic couplers must be clear of debris, dust, and sand. Use protective caps on fluid openings until ready to make connection. Foreign material can damage the hydraulic system.

NOTE: To help identify and properly connect hoses, refer to Figure 5 below.

Assembly

When the LL12 arrives at the dealership the tongue (reference number 3 in figure 5) will be laying under the leveling scraper on the pallet.

To assemble the LL12 remove it from the shipping pallet and set the unit onto a level surface. Then remove the tongue off of the pallet and use the bolts (reference numbers 32, 33, 34, 35, 36, and 37 in figure 5) that are seated in the

tongue to attach the tongue to the unit.

The hydraulic hoses (reference numbers 23, 24, 48, and 49 in figure 5) that are connected to the hydraulic cylinders must be ran through the hose clamps (reference number 28 in figure 5) located on the tongue.

Once the scraper is assembled, refer to “set up” on page 13 for instructions on leveling the machine with the side cutter blades.

Optional Equipment

The tilting axle is the only available option on the LL12. The tilting axle is easily used by compressing or extending the hydraulic cylinders rod. This will tilt the scraper in the left or right direction.

To re-level the scraper after using the tilting feature just set the blade on a level surface and lift the wheels off of the ground by using the lift cylinder. Next contract the tilting cylinder to bring the right rear wheel up. Then lower the lift cylinder until the left wheel is touching the ground. Now extend the tilting cylinder rod until the right rear tire is touching the ground. Now both tires will be touching the ground at the same time. At this point the scraper is level.

15 Operations

Parts Catalog

LL12 Series Drawn Box Scraper

Figure 5

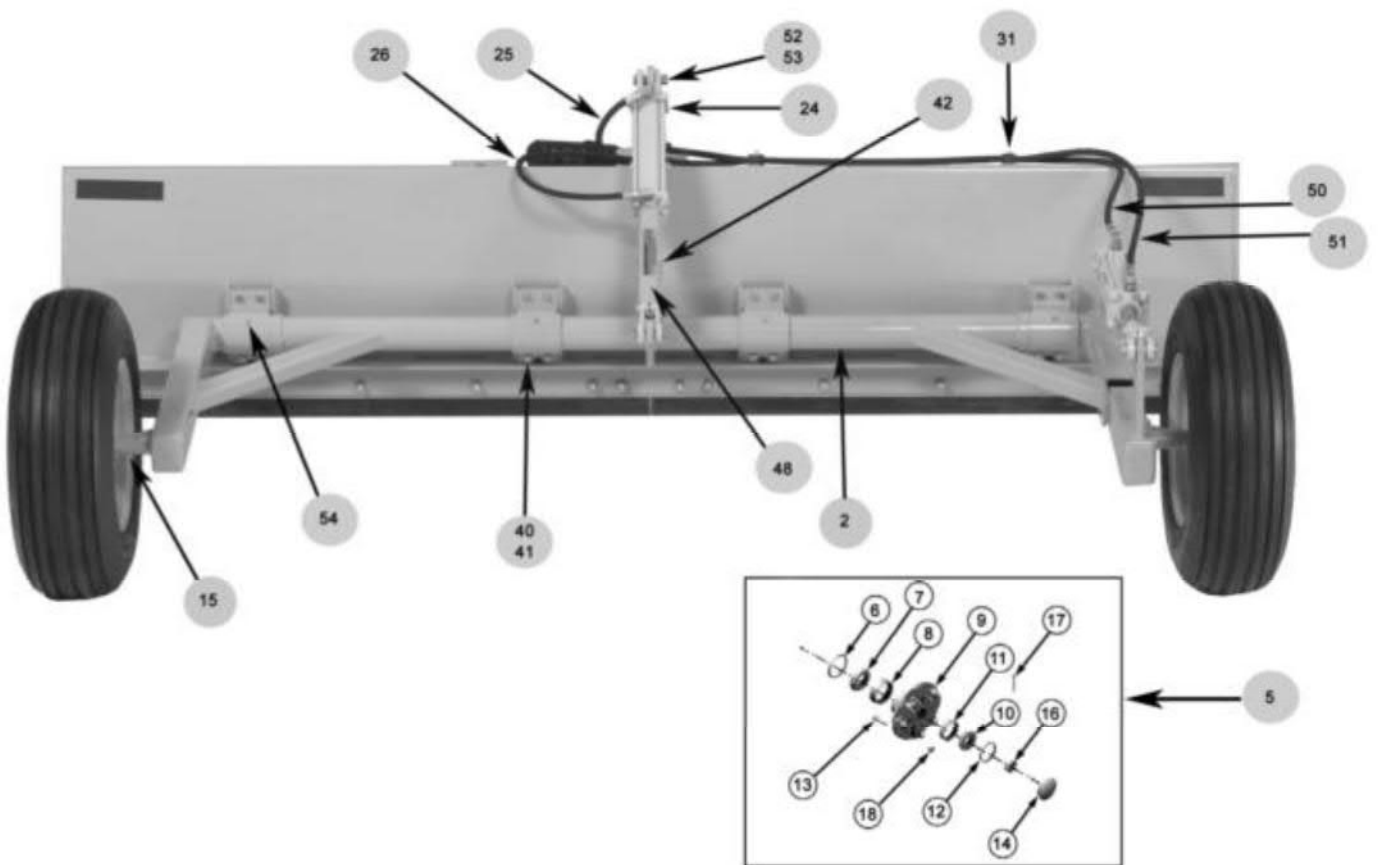
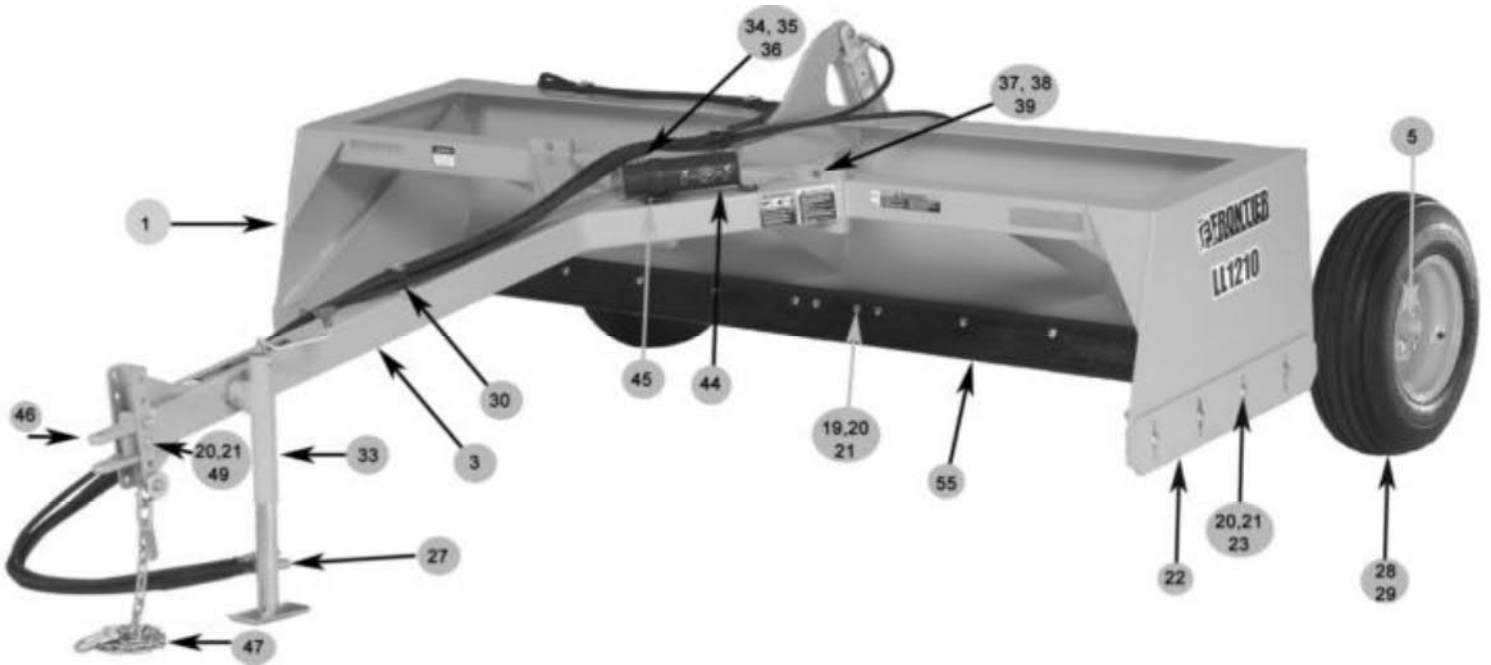

16 Parts Diagram

LL12 Series Drawn Box Scraper Parts Catalog Ref. Figure 5

Ref.#	Part #	Description	Qty.
1	5DDM00604	MAIN FRAME WELDMENT 8 FT	1
	5DDM00593	MAIN FRAME WELDMENT 10 FT	1
	5DDM00594	MAIN FRAME WELDMENT 12 FT	1
2	5DDM00597	LIFT AXLE FOR 8 FT AND 10 FT WITHOUT TILT	1
	5DDM00598	LIFT AXLE FOR 12 FT WITHOUT TILT	1
	5DDM00599	LIFT AXLE FOR 8 FT AND 10 FT WITH TILT	1
	5DDM00600	LIFT AXLE FOR 12 FT WITH TILT	1
3	5DDM00601	TONGUE WELDMENT	1
4	5DDP00516	RATCHET ASSEMBLY FOR REAR WHEEL (NOT SHOWN)	1
5	5DDP00517	HUB ASSEMBLY (COMPLETE)	2
6	5DDP00527	INNER BEARING SEAL (HUB COMPONENT)	2
7	5DDP00528	INNER BEARING (HUB COMPONENT)	2
8	5DDP00529	INNER BEARING RACE (HUB COMPONENT)	2
9	5DDP00530	HUB HOUSING (HUB COMPONENT)	2
10	5DDP00531	OUTER BEARING (HUB COMPONENT)	2
11	5DDP00532	OUTER BEARING RACE (HUB COMPONENT)	2
12	5DDP00533	OUTER BEARING SEAL (HUB COMPONENT)	12
13	5DDP00534	WHEEL STUD (HUB COMPONENT)	12
14	5DDP00535	HUB CAP (HUB COMPONENT)	2
15	5DDP00518	SPINDLE ASSEMBLY	2
16	5DDP00338	CASTLE NUT (HUB COMPONENT)	2
17	5DDP00339	COTTER PIN (HUB COMPONENT)	2
18	5DDP00340	WHEEL NUT (HUB COMPONENT)	1
19	5DDP00178	GRADE 8 5/8 X 2.25 ZINC PLATED PLOW BOLTS	MS
20	5DDP00119	5/8 THRU-HARDENED LOCK WASHER	MS
21	5DDP00120	5/8 GRADE 8 HEX NUT	MS
22	5DDP00398	SIDE CUTTER BLADES	2
23	5DDP00399	5/8 X 2 GRADE 5 ZINC CARRIGE BOLTS	8
24	5DDP00247	3 X 8 HYDRAULIC CYLINDER	1
25	5DDM00595	HYDRAULIC HOSE – TRACTOR TO FRONT OF LIFT CYLINDER	1
26	5DDM00596	HYDRAULIC HOSE – TRACTOR TO REAR OF LIFT CYLINDER	1
27	5DDP00113	MALE HYDRAULIC TIP	2
28	5DDP00519	8 X 15 WHEELS WITH 6 BOLT STD.	2
29	5DDP00520	9.5L X 15 TIRES	2
30	5DDP00521	DOUBLE HOSE CLAMP	2
31	5DDP00522	SINGLE HOSE CLAMP	2
32	5DDP00523	JACK BRACKET (NOT SHOWN – LOCATED INSIDE OF THE BOX)	1
33	5DDP00232	JACK ASSEMBLY	2
34	5DDP00135	GRADE 8 3/4 X 2 HCS	4
35	5DDM00136	3/4 THRU-HARD LOCK WASHER	4
36	5DDM00137	3/4 GRADE 8 HEX NUTS	4

17 Parts Catalog

LL12 Series Drawn Box Scraper Parts Catalog(cont'd.)

Reference Page 15, Figure 5

Ref.#	Part #	Description	Qty.
37	5DDP00221	½ X 1.5 GRADE 8 BOLTS	4
38	5DDP00224	½ GRADE 8 HEX NUT	4
39	5DDP00223	½ THRU-HARD LOCK WASHER	4
40	5DDP00524	½ NYLON LOCK NUT	16
41	5DDP00525	½ X 1 GRADE 8 BOLTS	16
42	5DDP00248	SNAPPER PINS 3/8 X 3	1
43	5DDP00537	DECAL SHEET LL1208 (NOT SHOWN)	1
	5DDP00526	DECAL SHEET LL1210 (NOT SHOWN)	1
	5DDP00536	DECAL SHEET LL1212 (NOT SHOWN)	1
44	5DDP00195	OWNERS MANUAL HOLDING TUBE	1
45	5DDP00194	MANUAL TUBE MOUNTING SCREWS	2
46	5DDP00272	HITCH ASSEMBLY	1
47	5DDP00270	SAFETY CHAIN	1
48	5DDM00530	TRANSPORT CYLINDER LOCK	1
49	5DDP00273	5/8 x 4.5 HCS, GRADE 8	2
50	5DDM00602	HYDRAULIC HOSE - TRACTOR TO FRONT OF TILT CYLINDER	1
51	5DDM00603	HYDRAULIC HOSE - TRACTOR TO REAR OF TILT CYLINDER	1
52	5DDP00249	HYDRAULIC CYLINDER CLEVIS PIN	MS
53	5DDP00407	HYDRAULIC CYLINDER COTTER PIN	MS
54	5DDP00111	1/8" NPT GREASE FITTING	4
55	5DDP00225	GRADER BLADES 5 FT	2
	5DDP00395	GRADER BLADES 6 FT	2
	5DDP00397	GRADER BLADES 8 FT	1

Note: All hydraulic hoses on the LL12 Series Drawn Box Scraper are 3/8" diameter. Specific lengths are listed in the parts list.



Suggest:

For more complete manuals. Please go to the home page.

<https://www.ebooklibonline.com>

If the above button click is invalid. Please download this document first, and then click the above link to download the complete manual.

Thank you so much for reading

Unified Inch Bolt and Screw Torque Values



Bolt or Screw	SAE Grade 1				SAE Grade 2 ^a				SAE Grade 5, 5.1 or 5.2				SAE Grade 8 or 8.2			
	Lubricated ^b		Dry ^c		Lubricated ^b		Dry ^c		Lubricated ^b		Dry ^c		Lubricated ^b		Dry ^c	
Size	N•m	lb-in	N•m	lb-in	N•m	lb-in	N•m	lb-in	N•m	lb-in	N•m	lb-in	N•m	lb-in	N•m	lb-in
1/4	3.7	33	4.7	42	6	53	7.5	66	9.5	84	12	106	13.5	120	17	150
													N•m	lb-ft	N•m	lb-ft
5/16	7.7	68	9.8	86	12	106	15.5	137	19.5	172	25	221	28	20.5	35	26
									N•m	lb-ft	N•m	lb-ft				
3/8	13.5	120	17.5	155	22	194	27	240	35	26	44	32.5	49	36	63	46
			N•m	lb-ft	N•m	lb-ft	N•m	lb-ft								
7/16	22	194	28	20.5	35	26	44	32.5	56	41	70	52	80	59	100	74
	N•m	lb-ft														
1/2	34	25	42	31	53	39	67	49	85	63	110	80	120	88	155	115
9/16	48	35.5	60	45	76	56	95	70	125	92	155	115	175	130	220	165
5/8	67	49	85	63	105	77	135	100	170	125	215	160	240	175	305	225
3/4	120	88	150	110	190	140	240	175	300	220	380	280	425	315	540	400
7/8	190	140	240	175	190	140	240	175	490	360	615	455	690	510	870	640
1	285	210	360	265	285	210	360	265	730	540	920	680	1030	760	1300	960
1-1/8	400	300	510	375	400	300	510	375	910	670	1150	850	1450	1075	1850	1350
1-1/4	570	420	725	535	570	420	725	535	1280	945	1630	1200	2050	1500	2600	1920
1-3/8	750	550	950	700	750	550	950	700	1700	1250	2140	1580	2700	2000	3400	2500
1-1/2	990	730	1250	930	990	730	1250	930	2250	1650	2850	2100	3600	2650	4550	3350

Torque values listed are for general use only, based on the strength of the bolt or screw. DO NOT use these values if a different torque value or tightening procedure is given for a specific application. For plastic insert or crimped steel type lock nuts, for stainless steel fasteners, or for nuts on U-bolts, see the tightening instructions for the specific application. Shear bolts are designed to fail under predetermined loads. Always replace shear bolts with identical grade.

Replace fasteners with the same or higher grade. If higher grade fasteners are used, tighten these to the strength of the original. Make sure fastener threads are clean and that you properly start thread engagement. When possible, lubricate plain or zinc plated fasteners other than lock nuts, wheel bolts or wheel nuts, unless different instructions are given for the specific application.

^aGrade 2 applies for hex cap screws (not hex bolts) up to 6 in. (152 mm) long. Grade 1 applies for hex cap screws over 6 in. (152 mm) long, and for all other types of bolts and screws of any length.

^b"Lubricated" means coated with a lubricant such as engine oil, fasteners with phosphate and oil coatings, or 7/8 in.

^c"Dry" means plain or zinc plated without any lubrication, or 1/4 to 3/4 in. fasteners.

**PART NO.
5DDP00538**



<https://www.ebooklibonline.com>

Hello dear friend!

Thank you very much for reading.

Enter the link into your browser.

The full manual is available for immediate download.

<https://www.ebooklibonline.com>