

OPERATOR'S MANUAL

GROOMING MOWERS

GM2060

GM2072

GM2084

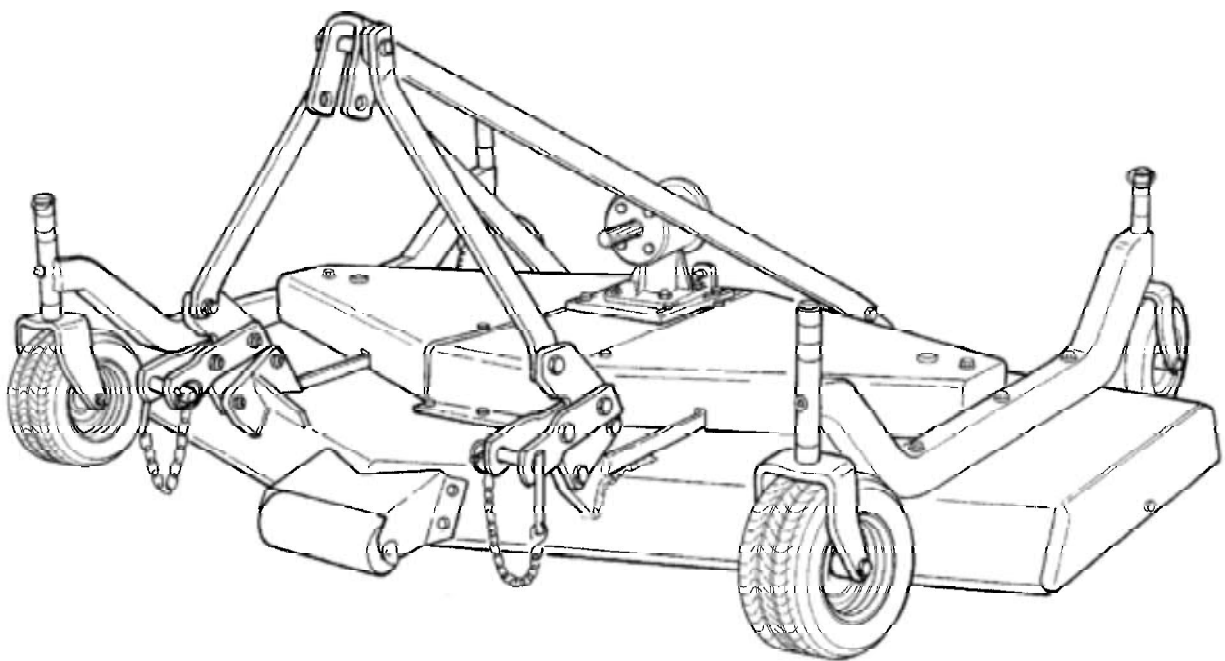

FRONTIER
EQUIPMENT

Manual 5BP960384B
Date 06/01/2009

SAFETY

Take note! This safety alert symbol found throughout this manual is used to call your attention to instructions involving your personal safety and the safety of others. Failure to follow these instructions can result in injury or death.



*This symbol means:
ATTENTION!
BECOME ALERT!
YOUR SAFETY IS INVOLVED!*

Signal Words

Note the use of the signal words DANGER, WARNING and CAUTION with the safety messages. The appropriate signal words for each have been selected using the following guidelines:



DANGER: Indicates an imminently hazardous situation that, if not avoided, will result in death or serious injury.



WARNING: Indicates a potentially hazardous situation that, if not avoided, could result in death or serious injury, and includes hazards that are exposed when guards are removed. It may also be used to alert against unsafe practices.



CAUTION: Indicates a potentially hazardous situation that, if not avoided, may result in minor or moderate injury.

INDEX

1 - GENERAL INFORMATION	4
1.01 - General	4
1.02 - Model and Serial Number ID	4
1.03 - Assembly Instructions	5
2 - SAFETY PRECAUTIONS	7
2.01 - Preparation	7
2.02 - Starting and Stopping	8
2.03 - Messages and Signs	8
3 - OPERATION	11
3.01 - Operational Safety	11
3.02 - Set Up	13
3.03 - Cutting Height Adjustment	13
3.04 - Pre-Operational Check	14
3.05 - Attaching to the Tractor	15
3.06 - Start Up	16
3.07 - Working Speed	17
3.08 - Operating Techniques	17
3.09 - Uneven Terrain	19
3.10 - Removing Mower from the Tractor	19
3.11 - Transport	19
3.12 - Quick Hitch Adapter Assembly and Operation	20
4 - MAINTENANCE	23
4.01 - Maintenance Safety	23
4.02 - Service	24
4.03 - Blade Maintenance	25
4.04 - Belt Tension	27
4.05 - Belt Replacement	28
4.06 - Driveline	29
5 - REPAIR PROCEDURES	32
5.01 - Gearbox	32
5.02 - Blade Spindle	32
5.03 - Suggested Spare Parts	33
5.04 - Storage	33
6 - TROUBLESHOOTING	34
7 - PRE-DELIVERY CHECKLIST	35
PARTS MANUAL	37

<https://www.ebooklibonline.com>

Hello dear friend!

Thank you very much for reading.

Enter the link into your browser.

The full manual is available for immediate download.

<https://www.ebooklibonline.com>

1 - GENERAL INFORMATION

Thank you and congratulations for having chosen our implement. Your new grooming mower is a technologically advanced machine constructed of high quality, sturdy components that will fulfill your working expectations. Read this manual carefully. It will instruct you on how to operate and service your mower safely and correctly. Failure to do so could result in personal injury and/or in equipment damage.

1.01 - General



CAUTION: Unless otherwise specified, all hardware is metric. Use only metric tools on metric hardware. Other tools that do not fit properly can slip and cause injury.



CAUTION: Right hand and left hand sides of the implement are determined by facing in the direction the implement will travel when going forward (see fig. 4).

1.02 - Model and Serial Number ID

Attached to the frame is an ID plate showing the model and the serial number. Record your implement model and serial number in the space provided below. Your dealer needs this information to give you prompt, efficient service when you order parts.



Warranty coverage is provided by John Deere according to the terms of the Agricultural/Commercial & Consumer Equipment Warranty Statement. Carefully read the warranty statement on the back of your original purchase order for details on coverage and limitations of this warranty.



Suggest:

For more complete manuals. Please go to the home page.

<https://www.ebooklibonline.com>

If the above button click is invalid. Please download this document first, and then click the above link to download the complete manual.

Thank you so much for reading

Your Authorized Company Dealer has genuine parts in stock. Only these approved replacement parts should be used.

1.03 - Assembly Instructions



CAUTION: Stand clear of bands when cutting as they could be under sufficient tension to cause them to fly loose. Take care in removing bands and wire. They often have extremely sharp edges and cut very easily.

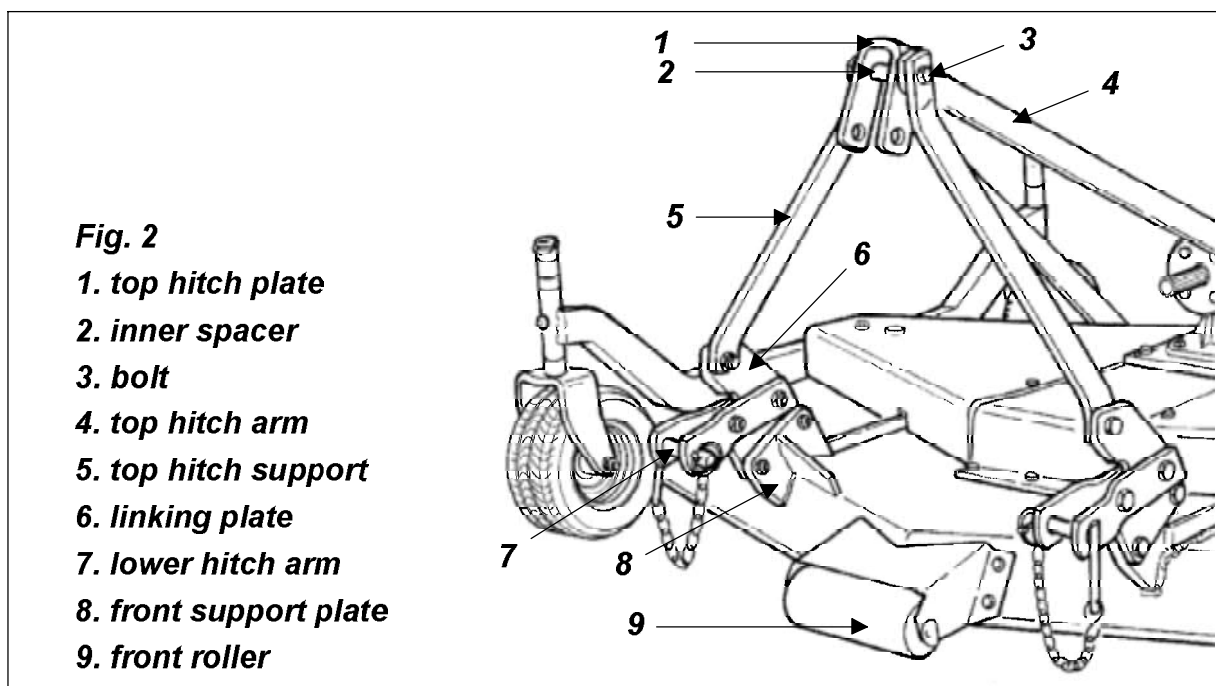

1. Unbolt the wheel arms from the side of the crate.
2. Remove the hardware bag secured to the top hitch arms.
3. **IMPORTANT:** Remove the belt shields to inspect around the belt area and under the gearbox central plate to be sure the area is clear of packing material such as blocks of wood, paper, etc.
4. Bolt the wheel arm assemblies to the mower deck with the flat washers $\varnothing 10$ and locknuts M10. There is no difference between left/right or front/rear. Be sure both assemblies are securely mounted.
5. Assemble each wheel to the yokes with one bolt M14x150, one nut M14, one inner bushing and two side spacers. Tighten down snugly. The wheel should turn freely but have no side to side movement.
6. Replace the belt shields.

7. Bolt up the top hitch arms (see #4, fig. 2 & 3) to the **outside** of the rear support plates (see #10, fig. 3) on the rear of the mower.
8. Bolt up the top hitch supports to the **inside** of the linking plates (see #6, fig. 2). **Use the top holes (see fig. 2).**
9. Bolt up the top hitch plate (see #1, fig. 2 & 3) with the bolt M16x140 (see #3, fig. 2). It should be bolted as follows: bolt, top hitch support, top hitch arm, top hitch plate, spacer, top hitch arm, top hitch support, locknut M16. **Tighten the locknut down securely, the top hitch plate should be able to swivel 360° (see fig. 2).**
10. Install the lower hitch arms (see #7, fig. 2) in the lower hole of the linking plates (see #6, fig. 2). If assembled properly, the hitch plates will rest on the "thumb" of the linking plate when down. Tighten the bolts holding the lower hitch arms. Be sure they are able to swivel.
11. Grease wheels, wheel arms, and spindles. Check the gearbox for oil. It should be approximately ½ filled.
12. Install driveline and ensure it has at least 2" from bottoming out in its shortest working position and has the minimum 6" overlap in its longest working position. Refer to **Section 4.06**¹ of this manual, if it is determined that the driveline is too long and needs to be shortened. Contact your local dealer if it is determined that the driveline is too short for your tractor .

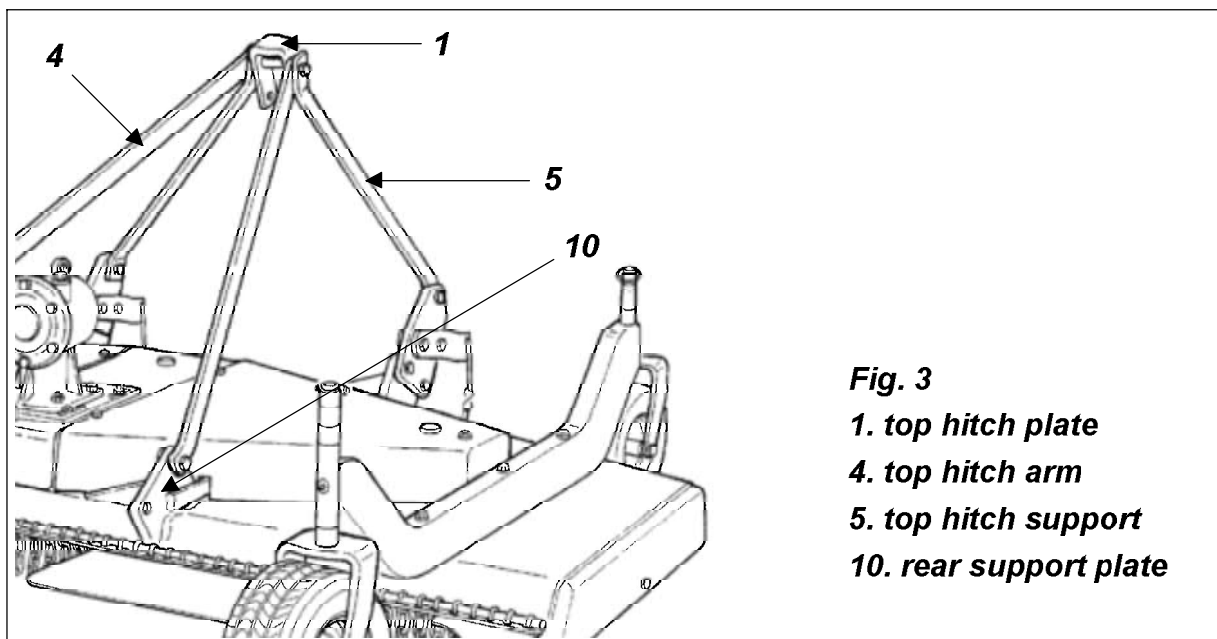

Fig. 3
1. top hitch plate
4. top hitch arm
5. top hitch support
10. rear support plate

¹ See Section 4.06 - Driveline, for instructions on how to determine correct driveline length and procedures for shortening the driveline.

<https://www.ebooklibonline.com>

Hello dear friend!

Thank you very much for reading.

Enter the link into your browser.

The full manual is available for immediate download.

<https://www.ebooklibonline.com>