

HOW TO CHECK YOUR G4 SPREAD PATTERN



SPINNER ASSEMBLY INSTALLATION



WARNING

Keep spinner assembly supported until mounting is complete. Never exceed workload limits or use slings to lift items over people.

Use the following instructions when installing a G4 Spinner Assembly on a L2020G4 or L3020G4:

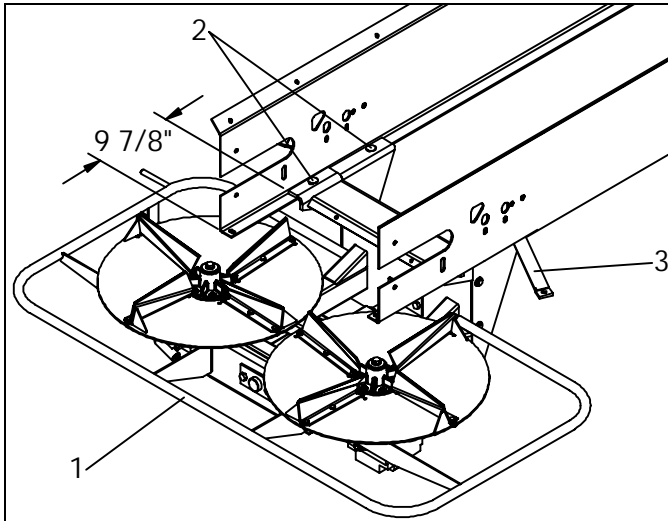

Figure A – Spinner Assembly Installation

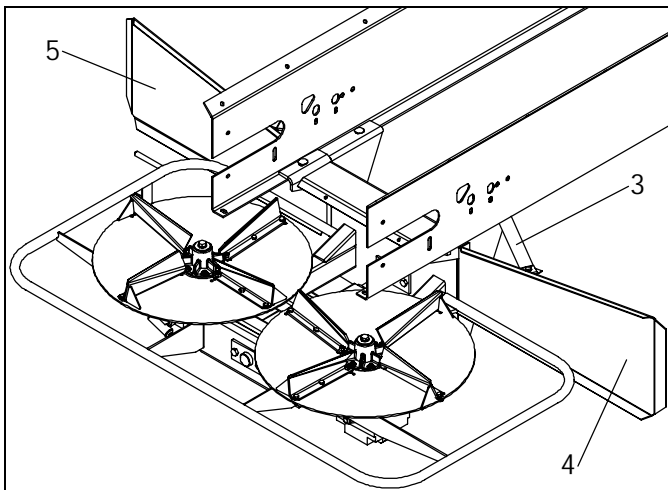

Figure B – Shield Installation

1. Use a suitable lifting device to hoist the spinner assembly (Item 1 - Figure A) onto the rear of the sills. Note: The spinner assembly weighs approximately 340 lbs. Align the spinner assembly holes with the sill holes. If assembling G4 spinner to GT unit, align spinner holes with front set of sill holes (closest to the cab). Insert four (4) carriage bolts (Item 2) through holes, place spinner shield supports (Item 3) on front bolts and attach with washers, lock washers and nuts. Hand-tighten only. Remove the two wooden 2 x 4's and hardware used during shipping.
2. Make sure the spinner assembly is square. Measure from the spinner mounting bracket that sits on the sill to the end of the sill on both sides. The distance should be approximately 9 7/8" on each side as shown in Figure A. Center the spinner assembly from side-to-side by measuring from the spinner hub to the sill on each side—these two measurements should be equal. Tighten the rear bolts securely.
3. See Figure B. Install the right-hand (Item 4) and left-hand (Item 5) spinner shields on the spinner assembly using four (4) cap screws, washers, lock washers and hex nuts. Attach the shield supports (Item 3) to the shields using two (2) cap screws, washers, lock washers and hex nuts. Tighten all shield support hardware securely, including the front bolts of the spinner assembly.
4. Install the pressure, return and case drain hoses. Crank the spinner assembly all the way forward and back to make sure the hoses and fittings do not interfere with the spinner assembly as it moves. Tie all loose areas of hose together with wire ties to prevent contact with moving parts during operation.

SPINNER ASSEMBLY INSTALLATION CONTINUED

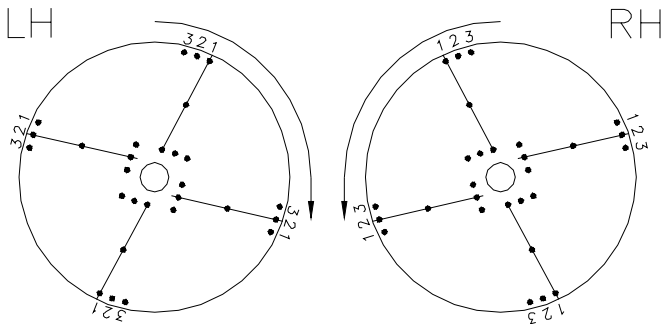

Figure C – L3020G4 Fin Location

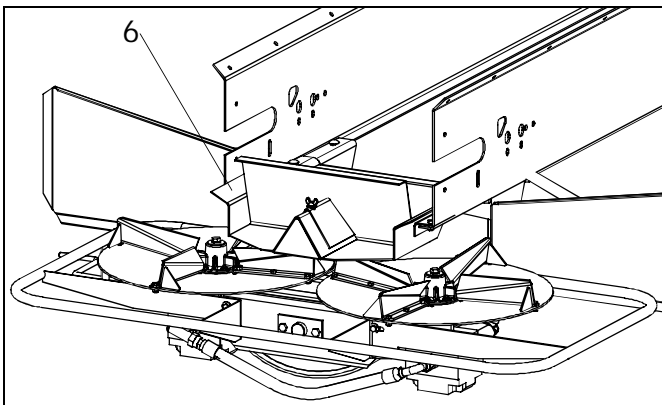

Figure D – Material Divider Installation

5. Make sure the fins are installed on the spinner discs correctly. When spreading with a L3020G4, position two opposing fins in the forward position (1) and two fins in the center position (2) as shown in Figure C. With a L2020G4, position all fins in the center position (2).
6. Measure the RPM of the spinners at operating engine RPM using a tachometer. Mark the control valve at the 500, 600, 700 and 800 RPM settings for future reference. Set at 700 initially. If the spreader has the optional tachometer installed on the spinner assembly, these settings can be found using the processor in the cab. If not, a hand held electronic tachometer should be used.
7. Position the material divider (Item 6) on the sills as shown in Figure D. Center the divider from side to side to make sure equal amounts of material go to each spinner and attach using two (2) cap screws, lock washers and hex nuts. (See note below.)

NOTE: If the unit does not have slots in the sills for the divider, holes must be drilled. Measure from the front plate of the spinner assembly to the drop-off point on the front plate of the material divider—the distance should be 12 1/4” on each side of the divider. The hold-down brackets on the material divider should be almost flush with the end of the sill. Mark the location of the material divider’s two (2) bolt holes on the sills. Remove the material divider and drill 3/8” holes where marked. Measure the distance from the spinner assembly’s front plate to the material divider’s drop-off point to make sure it’s at 12 1/4”. Adjust as necessary and tighten hardware.

<https://www.ebooklibonline.com>

Hello dear friend!

Thank you very much for reading.

Enter the link into your browser.

The full manual is available for immediate download.

<https://www.ebooklibonline.com>

SPINNER ASSEMBLY INSTALLATION CONTINUED

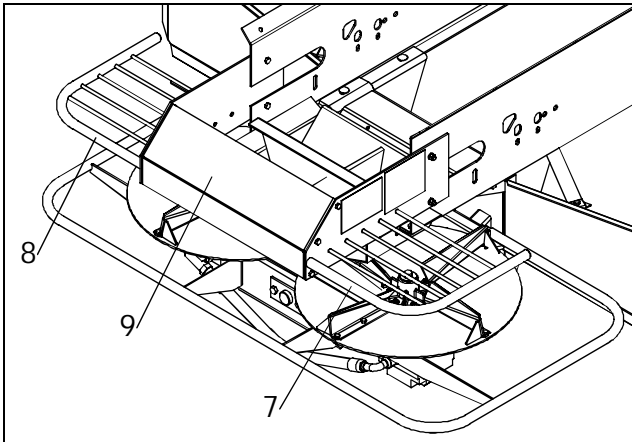

Figure E – Spinner Guard Installation

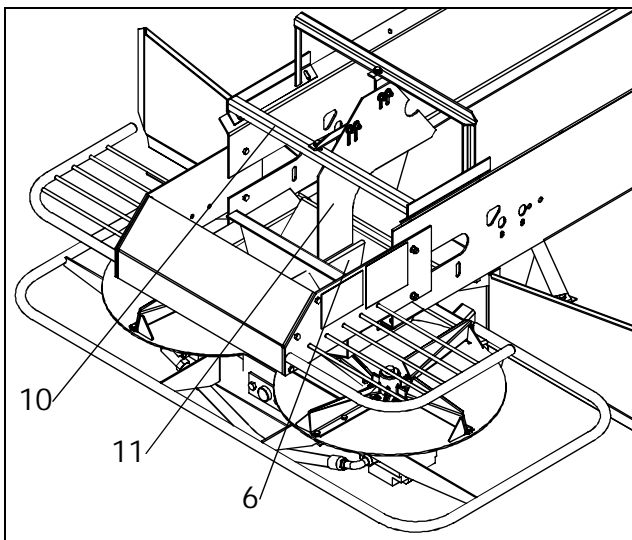

Figure F – Hillside Divider Installation

8. Mount the right-hand (Item 7) and left-hand (Item 8) spinner guards on the sills as shown in Figure E, using two (2) cap screws, lock washers and hex nuts per side. Hand tighten only. Install the center spinner guard (Item 9) between the two sides and attach using six (6) cap screws, washers and lock nuts. Level guard and tighten hardware securely.
9. Remove the two rear chain shield cap screws from each side. Install the hillside divider (Item 10) as shown in Figure F, using the chain shield hardware. Make sure the hillside divider panel (Item 11) is straight and level so it will distribute materials evenly to the material divider (Item 6). Do not set the panel directly on the conveyor. Tighten hillside divider hardware securely.
10. Grease all lubrication points—two grease zerks are located on the jack under the spinner assembly and two are on the shaft. Lubricate the spreader according to the lubrication chart.
11. Check all hoses, fittings and hardware on the spinner assembly and tighten as necessary.

ADJUSTING THE SPREAD PATTERN

IMPORTANT!

Spinner assembly has NOT been adjusted at the factory. Before spreading material, spread pattern tests must be conducted to properly adjust the spread pattern. A Spread Pattern Test Kit, part number 70889, is available for this purpose. **THE MANUFACTURER OF THIS SPREADER WILL NOT BE LIABLE FOR MISAPPLIED MATERIAL DUE TO AN IMPROPERLY ADJUSTED SPREADER!**

It is recommended that spread pattern tests be conducted prior to each spreading season, after any spreader maintenance, and periodically during the spreading season. Spread pattern tests must be conducted whenever a new product is to be applied.

Spread pattern is affected by many factors. Among the more significant of these are:

1. Spinner speed.
2. Material weight per cubic foot.
3. Material granule size.
4. Material flow characteristics.
5. Rate of delivery of material.
6. Point of delivery of material on spinner discs.
7. Balance between deliveries to both spinner discs.
8. Angle of the distributor fins on the spinner discs.
9. Cleanliness of the spinner fins and discs.
10. Level of spreader.
11. Wind and humidity.
12. Spacing of swaths.
13. Wear on spinner fins.

Since many of these factors will vary for each job, trial and experience must be used to determine the adjustments which must be made to obtain the spread width and spread pattern desired. The following instructions are given to cover the adjustments available and the effect that each will have on the spread pattern.



WARNING

As contact with spinners and other moving parts is very dangerous, great caution must be used while working around the spreader. Do not adjust while machinery is moving, wear eye protection and avoid discharge from spinners. Do not ride on moving spreader.

ADJUSTING THE SPREAD PATTERN CONTINUED**A. SPINNERS****IMPORTANT!**

Spinner discs and fins must be kept clean and polished. Even a small build-up on a spinner fin can significantly affect the spread pattern. Rusty, rough, bent or worn fins will produce poor spread patterns.

Fan speed is adjustable from approximately 400 to 800 RPM. This is accomplished by moving the spinner speed control valve lever.

Proper fan speed adjustment is very important in obtaining good spread patterns. The best fan speed to use will depend entirely on the material being spread, and must be determined by testing. Once established for the materials you use, paint marks on the control valve body as shown in Figure G.

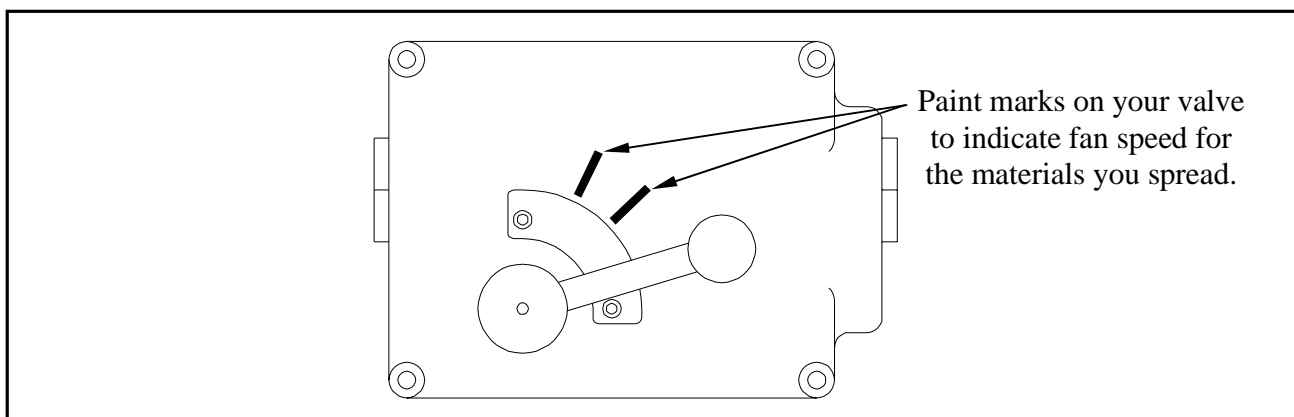

Figure G - Spinner Control Valve

Maximum pattern width is determined by particle size. This may vary anywhere from 25 feet for very finely ground dry lime up to 120 feet or more for extremely large fertilizer pellets.

For every particle size and density, there is a critical fan speed. In other words, there is a speed which will result in the maximum width obtainable. Going beyond this speed will not increase spread width, but will result in poor patterns.

Too high a fan speed could result in a heavy deposit behind the truck due to break-down of material. This upper speed limit will be quite low for finely powdered material, and will be very high for extremely coarse materials. In general, this critical speed will fall somewhere between 500 and 800 RPM for ordinary materials.

One way to adjust fan speed is to watch the material leaving the fans. At slow speed the material leaves the blades in bands. At medium speed it forms wide bands in the air. At somewhat higher speed, the bands close into a uniform blur. Normally, the proper fan speed is slightly higher than that when the bands close to a blur.

TEST EQUIPMENT AND PROCEDURES

It is recommended that a spread pattern test be performed for all products you handle. Once initial testing is completed, testing should be repeated at the beginning of every season, or any time repair work is performed on any component affecting spread patterns.

SPREAD PATTERN TEST KIT

<u>PART NO.</u>	<u>DESCRIPTION</u>	<u>QTY</u>	<u>PART NO.</u>	<u>DESCRIPTION</u>	<u>QTY</u>
300508	Kit - Spread Pattern Test, Includes the Following:				
70890	Collection Tray	21	99418	Data Sheets	100
87200	Divider	21	300503	Screw – #6-32 x 3/8	42
300506	Rack – Tube	1	300504	Nut – Lock #6-32	42
300507	Test Tubes	21	70897	Flags	5
300505	Clip – Molded	21	87199	Rope – 120' marked	1
87332	Funnel	1	87201	Stakes	2

SPREADER PREPARATION

The spreader to be tested shall be in good mechanical condition and properly adjusted according to the Operation and Maintenance Manual.

All damaged and worn parts must be replaced. Spinner discs and blades must be free of any material build-up, rust or paint.

Fill the hopper with the material to be spread. Run the material out to the end of the conveyor.

Set the feedgate to deliver the required rate per acre. Make sure the feedgate is level and the indicator reflects the actual gate opening measured by standing a tape measure vertically in the fertilizer. NOTE: Do not follow contour of sloped endgate when making this measurement.

Adjust the spinner assembly by turning the crank. To begin testing, position the spinner according to the chart below. NOTE: This chart is to be used as a reference only to begin testing.

MATERIAL (Weight in Pounds)	SPINNER POSITION (SEE DECAL)	MATERIAL (Weight in Pounds)	SPINNER POSITION (SEE DECAL)
LIME – LIGHT (80-90)	1	FERTILIZER (65)	3
LIME – HEAVY (100)	0	UREA (48)	4

TEST EQUIPMENT AND PROCEDURES CONTINUED

TEST PROCEDURE

The area selected for testing, measuring 120 feet x 400 feet, should have a slope of less than two degrees.

Insert a plastic grid into each of the 21 collection trays. Position the 21 collection trays on six-foot (6') centers with the longest dimension of the tray parallel to the direction of travel. (Figure H)

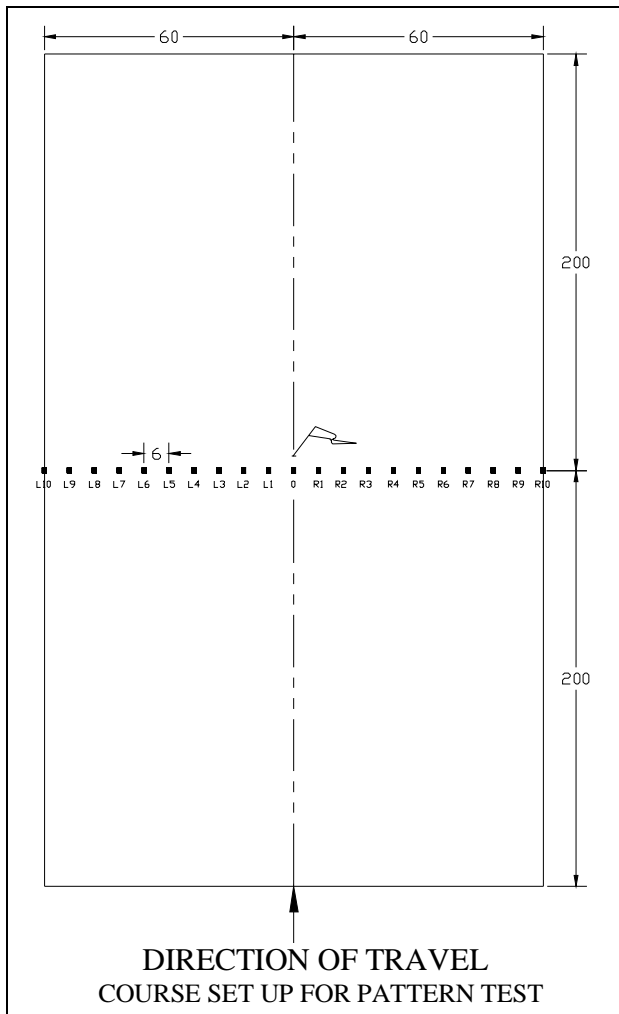

Figure H – Tray Positions

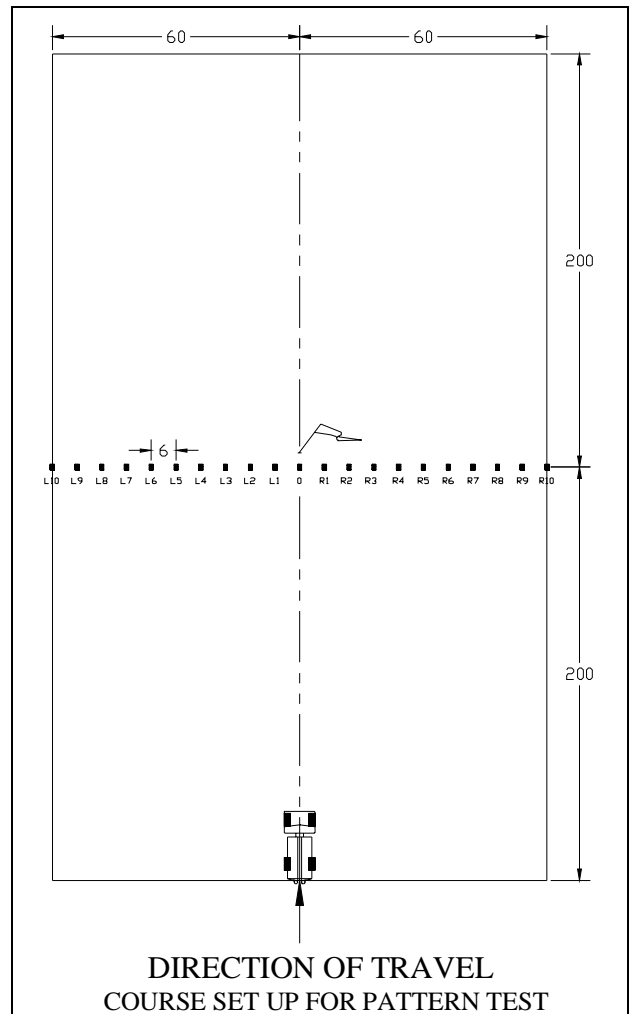

Figure I – Spreader Position

TEST EQUIPMENT AND PROCEDURES CONTINUED

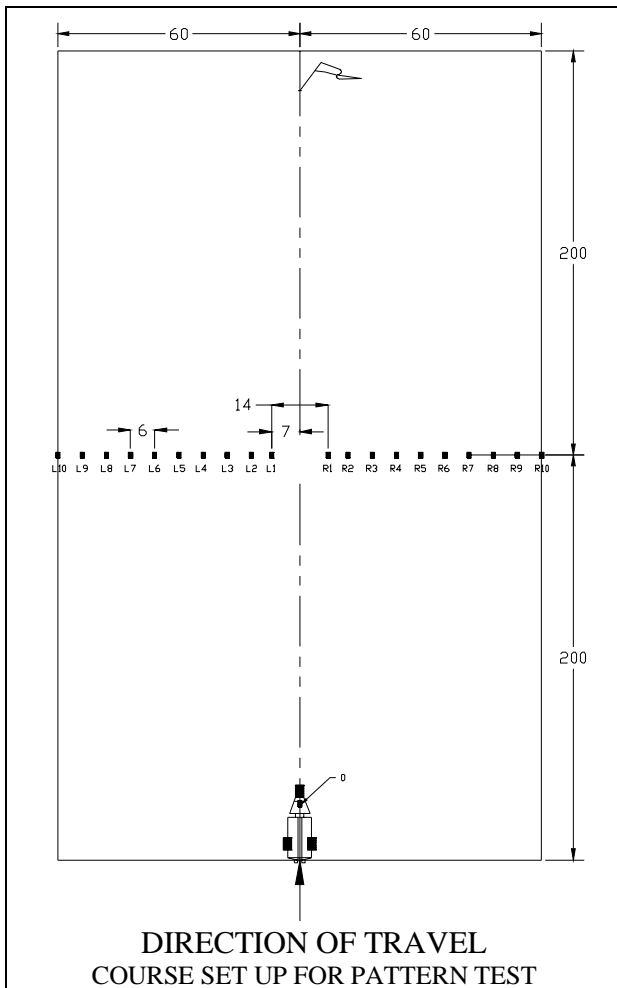

Figure J – 3-Wheeler Position

All testing should be done when the wind velocity is less than 5 MPH. If wind is present, testing must be done with spreader traveling parallel (within ± 15 degrees) to the wind direction.

Do not allow loaded spreader to sit for more than four hours prior to testing.

Prior to driving the spreader through the test course, it should be driven at least 450 feet at spreader test speeds.

Spreader must be driven over the collection trays in **ONLY ONE DIRECTION**.

Position spreader at the beginning of the course so that vehicle will straddle center collection tray. (Figure I, page 8) **NOTE:** If vehicle is a three-wheeled type, straddling the center tray will not be possible—place center tray behind front tire when the spreader is in position at beginning of course and move the two adjacent trays from the 6 foot to a 7 foot position from point “0”. (Figure J)

Set gate opening based on desired rate/acre according to theoretical application charts supplied with each unit.

Drive spreader completely through course at normal operating speeds. **NOTE:** If vehicle is a three-wheeled type, the operator should select a lower gear ratio than normally used. By selecting a gear ratio that will produce 5 to 7 MPH at normal operating engine RPM, the vehicle will be traveling slow enough so that the spreader will be at full RPM before passing over the center collection tray.

DATA RECORDING

Using the data sheets supplied with the kit, document all spreader adjustments required.

Using the funnel, transfer the contents of each collection tray into its corresponding test tube beginning at one end of the trays and working towards the opposite end.

Record the volume in each test tube in the box on the data sheet under the corresponding tray position. (Figure K, Page 10) **NOTE:** It is highly recommended that **ONLY ONE ADJUSTMENT** be made between test samples taken. If more than one adjustment is made, it will be difficult to determine which adjustment was responsible for the change in pattern shape.

TEST EQUIPMENT AND PROCEDURES CONTINUED

Pattern Test No. <u>2</u>	Material Used <u>FERTILIZER</u>	Spinner Indicator Setting <u>3 1/2"</u>
Site <u>HECO</u>	Weight/Cu.Ft. <u>60#</u>	Drop-off Point to CL Distance <u>2"</u>
Date <u>3 20 00</u>	Rate/Acre <u>200</u>	Blade Settings <u>2 1 2 1</u>
Spreader Model <u>L3020G4</u>	Gate Opening <u>2 1/2</u>	Spinner Valve Setting <u>7</u>
Conveyor Type <u>#4</u>	Wind: From _____ at _____ MPH	Spinner RPM <u>700</u>

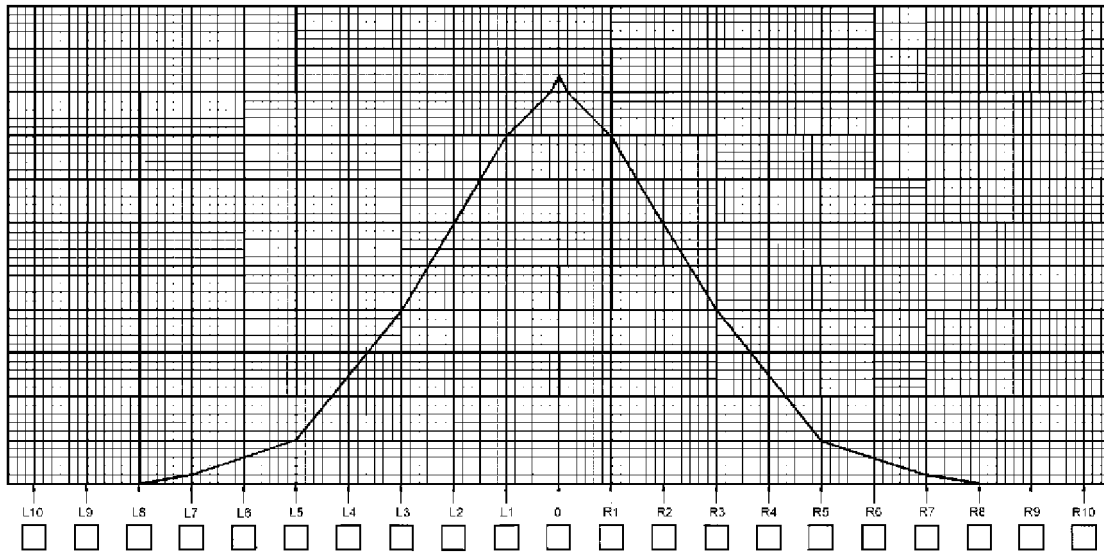
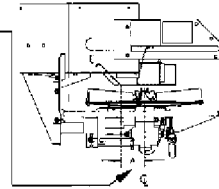

Pattern Test No. <u>3</u>	Material Used <u>FERTILIZER</u>	Spinner Indicator Setting <u>3"</u>
Site <u>HECO</u>	Weight/Cu.Ft. <u>60#</u>	Drop-off Point to CL Distance <u>2"</u>
Date <u>3 20 00</u>	Rate/Acre <u>200</u>	Blade Settings <u>2 1 2 1</u>
Spreader Model <u>L3020G4</u>	Gate Opening <u>2 1/2</u>	Spinner Valve Setting <u>7</u>
Conveyor Type <u>#4</u>	Wind: From _____ at _____ MPH	Spinner RPM <u>700</u>

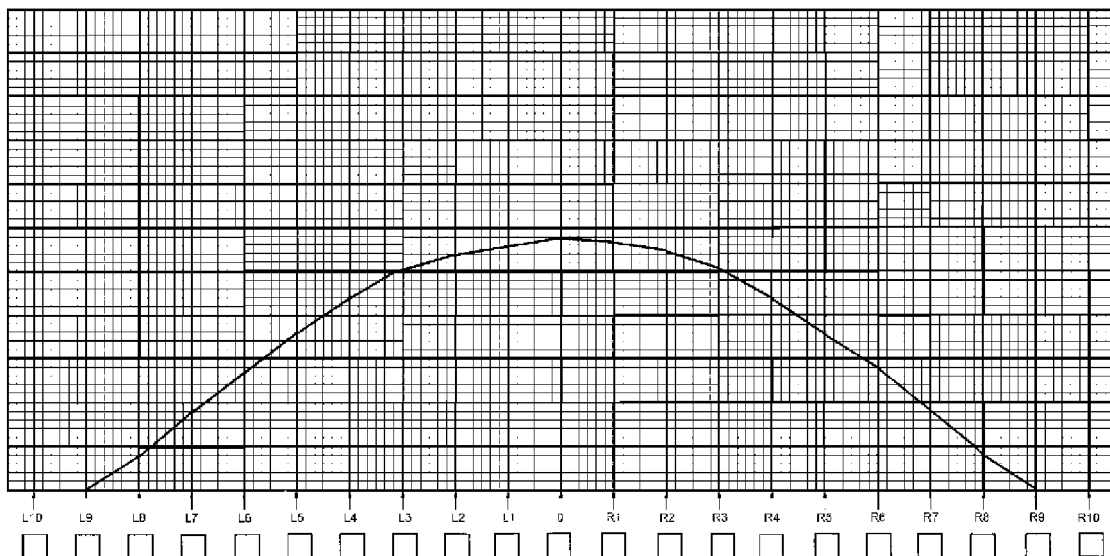
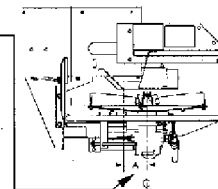

Figure K – Spread Chart Example



Suggest:

For more complete manuals. Please go to the home page.

<https://www.ebooklibonline.com>

If the above button click is invalid. Please download this document first, and then click the above link to download the complete manual.

Thank you so much for reading

TEST EQUIPMENT AND PROCEDURES CONTINUED

Once you attain one of the three desirable pattern shapes (Figure N), optimum-driving centers can be determined. To determine optimum driving centers (effective swath width), locate the points on both the left and right side of the graph where the amount of material applied is half the amount at the “0” foot mark (center tube). The distance between these two points represents the driving centers to be used.

When blended fertilizers are being applied, a visual inspection of the samples should be made to determine whether the blend within the effective swath width is consistent with the desired blend. If the blend is not consistent, a narrower overall swath width should be used and a new optimum driving center (effective swath width) should be determined.

Once the effective swath width has been established, a change in the processor may be required.

RECOMMENDED DRIVING METHOD

It is highly recommended to use the perimeter driving method (Figure L) whenever possible, as this method compensates for non-symmetrical patterns by blending the right side of the pattern with the left side of the adjacent pattern or vice versa.

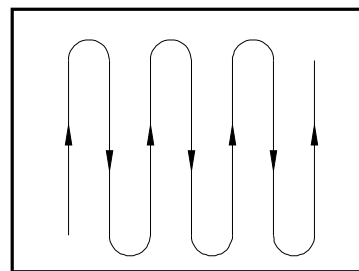
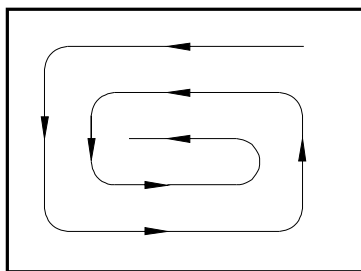

Figure L – Perimeter Method Figure M – Switch Back Method

However, due to the irregular shapes of some fields, the only practical driving method is “Switch Back.” (Figure M) When this method is utilized, the driver should be aware that non-symmetrical patterns are amplified by blending right side on right and left side on left.

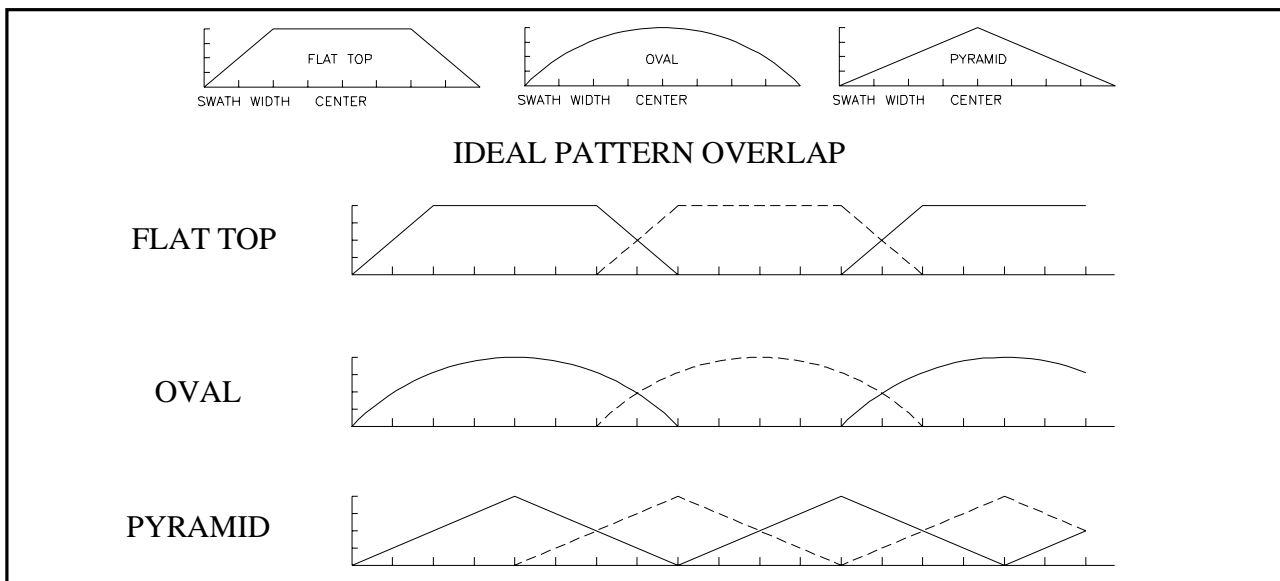

Figure N - Acceptable Patterns

TROUBLESHOOTING

PROBLEMS

PATTERNS

RECOMMENDED ADJUSTMENTS

Heavy Directly Behind the Vehicle

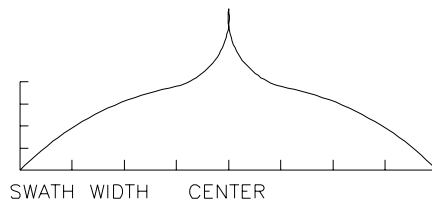

1. Move the spinner forward (toward the conveyor).
2. Decrease spinner RPM.
3. Move one or two spinner blades to a lower numbered hole.

Light Directly Behind the Vehicle

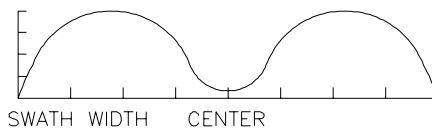

1. Move the spinner rearward (away from conveyor).
2. Increase spinner RPM.
3. Move one or two spinner blades to a higher numbered hole.

Light Outside Vehicle's Tire Tracks

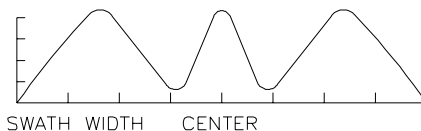

1. Move the spinner blades to hole numbers 1, 2, and 3 on each disc.
2. Decrease spinner RPM.

Pattern Off Center

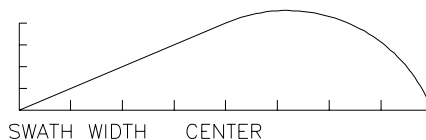

1. Check to see feedgate is level and free of caked material.
2. Make sure hillside divider is mounted squarely and centered.
3. Check to be sure spinner assembly is mounted squarely and centered.
4. Make sure material divider is mounted squarely and centered.
5. Testing should be done parallel to wind.

<https://www.ebooklibonline.com>

Hello dear friend!

Thank you very much for reading.

Enter the link into your browser.

The full manual is available for immediate download.

<https://www.ebooklibonline.com>