

OPERATOR'S MANUAL

ROTARY BROOM

SW2160 | SW2172 | SW2184

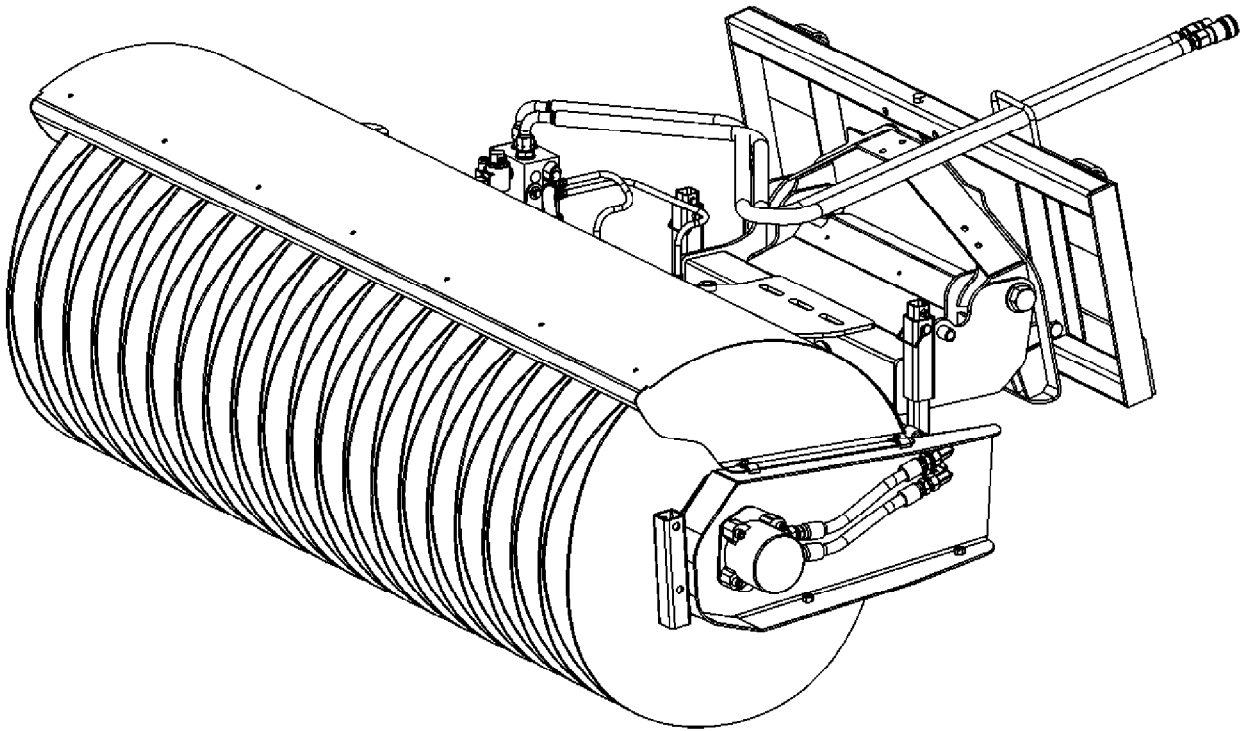

OM 0402BR-A

01/11

TABLE OF CONTENT

SPECIFICATIONS.....	3
INTRODUCTION – TO THE PURCHASER.....	4
SAFETY PRECAUTIONS	5-12
Before Operation.....	5
Notice.....	6
The Rotary Broom.....	6
Before Operation	6
Broom Operation	7
The Tractor.....	8
General Information.....	8
Operating the Tractor	8
During Operation	9
Roll-Over Protective Structure (ROPS) (if equipped)	9
Additional Safety Equipment	9
Maintenance	10
Transport	11
Storage	11
DECALS	12
ASSEMBLY	13-33
Broom Assembly	13
Installation of Broom on Front Loader	13
Installation of the Hydraulic Hoses	14
Installation of Electrical Wiring – Tractor With Cab.....	15-19
Installation of Electrical Wiring – Open StationTractor	20-25
Installation of the Switchbox 5RD669285 - Option	26
Installation of Dust Deflector – 5RDF0030-0031-0032	27
Installation Lawn Dethatching Wheel Support – 5RDF0034.....	28-29
Installation Lawn Dethatching Wheel kit – 5RDF0033.....	30
Installation of the Cooling Unit – 5RDF0036.....	31-32
Removing the Broom from the Front Loader	33

TABLE OF CONTENT

OPERATION.....	34-37
Optimum Performances	34
General Preparation.....	34
Operating Controls	34
Hydraulic Angling Adjustment	34
Ground Pressure Adjustment	35-36
General Sweeping.....	36
Lawn Dethatching & Lawn Raking	37
MAINTENANCE.....	38-46
Maintenance	38
Hydraulic Oil	38
Storage.....	38
Brush Replacement.....	41-40
Compression Springs	40
Lubrication	41
Verification	41
Troubleshooting	42-44
Hydraulic Diagram	45
Electric Diagram.....	46
TORQUE SPECIFICATION TABLE.....	47-49

<https://www.ebooklibonline.com>

Hello dear friend!

Thank you very much for reading.

Enter the link into your browser.

The full manual is available for immediate download.

<https://www.ebooklibonline.com>

<https://www.ebooklibonline.com>

Hello dear friend!

Thank you very much for reading.

Enter the link into your browser.

The full manual is available for immediate download.

<https://www.ebooklibonline.com>



Suggest:

For more complete manuals. Please go to the home page.

<https://www.ebooklibonline.com>

If the above button click is invalid. Please download this document first, and then click the above link to download the complete manual.

Thank you so much for reading

SPECIFICATION

Features and Specifications	SW2160	SW2172	SW2184
Width – in (cm)	72 (183)	84 (213)	96 (244)
Working width, straight – in (cm)	60 (152)	72 (183)	84 (213)
Working width at maximum angle – in (cm)	55 (140)	66 (168)	77 (196)
Working Height – in (cm)	34 (87)	34 (87)	34 (87)
Length – in (cm)	69 (175)	69 (175)	69 (175)
Recommended Flow – GPM	12 to 22	12 to 22	12 to 22
Recommended Pressure- PSI	2100 to 3600	2100 to 3600	2100 to 3600
Number of wafer	34	39	46
Type of brush	"Z"	"Z"	"Z"
100% polypropyl. Brush	Standard	Standard	Standard
Polypropyl./steel (50/50)	Option	Option	Option
Brush diameter – in (cm)	32 (81)	32 (81)	32 (81)
Brush speed with Hydraulic Pump HP series -rpm	160	160 – HP2025 200 – HP2134	200
Hydraulic Angling	Standard	Standard	Standard
Angling Range	23°-0°-23°	23°-0°-23°	23°-0°-23°
Shear Pin	Standard	Standard	Standard
Loader Compatibility	Current JD 300 Series Loader Carriers	Current JD 300 & 400 Series Loader Carriers	Current JD 400 Series Loader Carriers
Dust Deflector	Option	Option	Option
Lawn Dethatching Wheel kit	Option	Option	Option
Parking Stand	Standard	Standard	Standard
Approx. shipping weight - lbs (kg)	1177 (314)	1197 (338)	1237 (363)
Brush Cover Thickness – ga (in)	14 – 0.0747	14 – 0.0747	14 – 0.0747
Side Panel Thickness – in (mm)	3/16 (5)	3/16 (5)	3/16 (5)
Broom drive	Hydraulic Motor 375 cc/rev.	Hydraulic Motor 375 cc/rev.	Hydraulic Motor 375 cc/rev.
Relief Valve Protection	Standard	Standard	Standard
Main hydraulic Hoses – in (mm)	3/4 (76)	3/4 (76)	3/4 (76)
Cooling Unit	Option	Option	Option
Dust Suppression system	Option	Option	Option
Rear Spraying Support	Standard	Standard	Standard
Hydraulic Power Pack compatibility	HP2025	HP2025 or HP2134	HP2134

Assembly time: 2-3 hours (including the hydraulic pump).