

OPERATOR'S MANUAL

SNOWBLOWER

SB2164 | SB2176

Serial # 1XFSB21X100058 and up

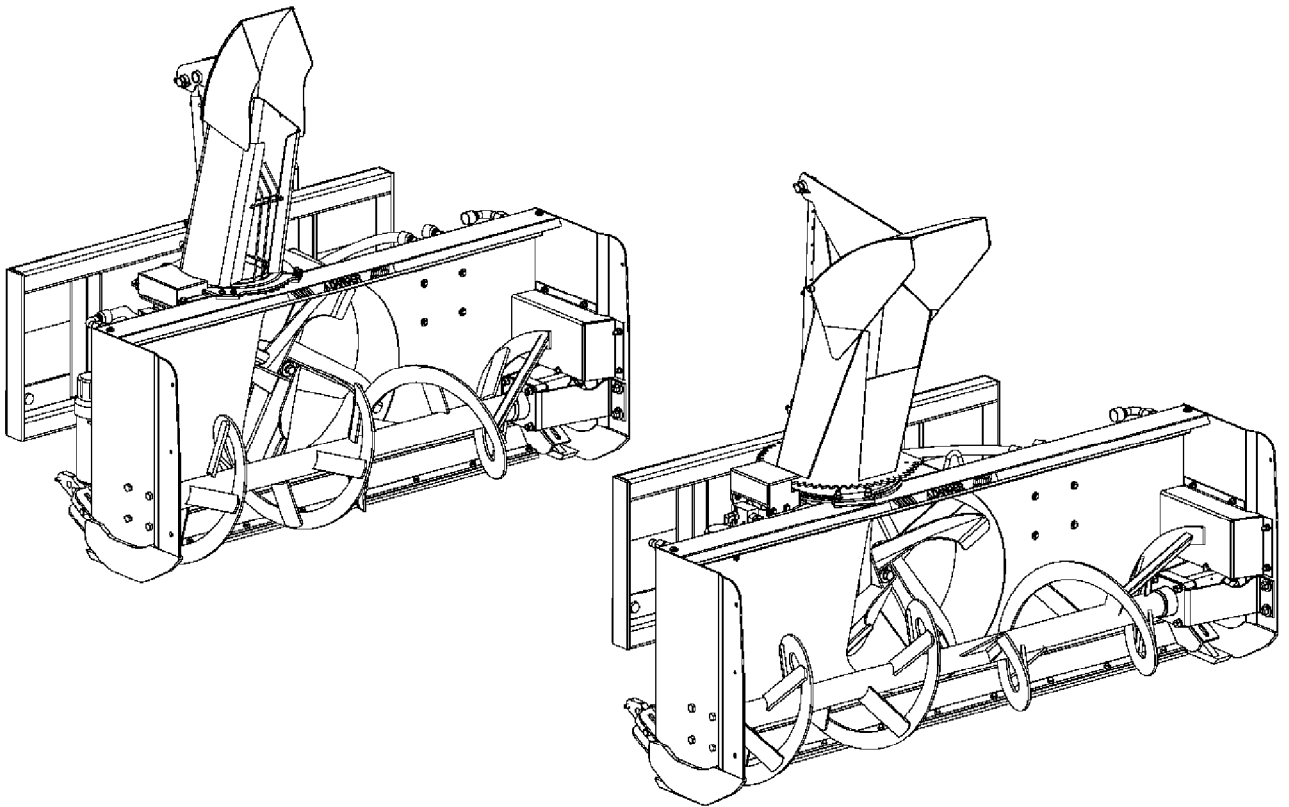

FRONTIER

TABLE CONTENT

SPÉCIFICATIONS.....	3
INTRODUCTION – TO THE PURCHASER.....	4
SAFETY PRECAUTIONS	5-11
Before Operation.....	5
Notice.....	6
The Snowblower	6
Before Operation	6
Snowblower Operation	7
The Tractor	8
General Information.....	8
Operating the Tractor	8
During Operation	9
Roll-Over Protective Structure (ROPS).....	9
Maintenance	10
Transport.....	11
Storage	11
DECALS	12
ASSEMBLY.....	13-40
Snowblower Assembly.....	13
Installation of the Chute for SB2176	13-14
for SB2164.....	15-16
Installation of the Snowblower.....	16
Installation of the Hydraulic Hoses	17
Installation of the Electrical Wiring	
– TRACTOR WITH CABIN (w/ 5RDF0039).....	18-22
– TRACTOR OPEN STATION (w/ 5RDF0039 and 5RDF0038)	23-28
Installation of the Switchbox 5RD669285 - Option.....	29
Installation of Hydraulic Deflector 5RDF0025 or 5RDF0027- Option	30-33
Installation of the Tractor side 132" Harness (5RDF0038) - TRACTOR WITH CABIN	34-35
- TRACTOR OPEN STATION	36-38
Installation of the Drift Cutters 5RDF0026 - Option	39
Removing the Snowblower.....	40

TABLE CONTENT

OPERATION	41-42
Optimum Performances	41
General Preparation	41
Operating Controls	41
Manual Deflector Adjustment	41
Hydraulic Deflector Adjustment	41
Hydraulic Rotation Adjustment	41
Ground Speed	42
Skid Shoe Adjustment	42
Snow Removal Methods	43
MAINTENANCE	44-53
Maintenance	44
Storage	44
Hydraulic Oil	44
Lubrication	45
Regular Inspections	45
Troubleshooting	46-47
Instruction For Valves Adjustment	48-51
Hydraulic Diagram	52
Electrical Diagram	53
TORQUE SPECIFICATION TABLE	54-56

<https://www.ebooklibonline.com>

Hello dear friend!

Thank you very much for reading.

Enter the link into your browser.

The full manual is available for immediate download.

<https://www.ebooklibonline.com>

<https://www.ebooklibonline.com>

Hello dear friend!

Thank you very much for reading.

Enter the link into your browser.

The full manual is available for immediate download.

<https://www.ebooklibonline.com>



Suggest:

For more complete manuals. Please go to the home page.

<https://www.ebooklibonline.com>

If the above button click is invalid. Please download this document first, and then click the above link to download the complete manual.

Thank you so much for reading

SPECIFICATIONS

Features and Specifications	SB2164	SB2176
Working Width	64"	76"
Transport Width	70"	88"
Working Height	27"	27"
Length	39"	39"
Single/Dual Auger	Single	Single
Auger Diameter	15"	15"
Auger Flighting Thickness	5/16"	5/16"
Impeller Diameter	24"	24"
Impeller Width	7"	8 1/2"
Impeller Shaft Diameter	1 1/4"	1 1/4"
Number of Impeller blades	4	4
Impeller RPM	680	580
Auger RPM	200	185
Skid Shoe	Adjustable 6 positions	Adjustable 6 positions
Skid Shoe Material	High carbon steel	High carbon steel
End Plate Thickness	3/16"	3/16"
Back Plate Thickness	11ga	11ga
Impeller Housing Thickness	11ga	11ga
Impeller Blade Thickness	1/4"	1/4"
Side Panel Bottom Thickness	1/2"	1/2"
Cutting Edge	Replaceable	Replaceable
Cutting Edge Dimension	3/8" x 2"	3/8" x 2"
Chute Base	Standard	Standard
Parking Stand	Standard	Standard
Loader Compatibility	Current JD 300 Series Loader Carriers	Current JD 400 Series Loader Carriers
Flow / Pressure	12 to 18 gpm @ 2700 psi	18 to 23 gpm @ 3000 psi
Oil Cooler	Standard	Standard
V.A.C. System	Standard	Standard
Fan Drive	89 cc/rev. Hydraulic Motor	127 cc/rev. Hydraulic Motor
Auger Drive	293 cc/rev. Hydraulic Motor	409 cc/rev. Hydraulic Motor
Relief Valve Protection	Fan, Auger & Rotation Motor	Fan, Auger & Rotation Motor
Main Hydraulic Hoses	3/4"	3/4"
Operating Weight (lbs)-hyd. rot. & deflector	N/A	760
Shipping Weight (lbs)	N/A	1060
Approx. Set-up Time	2 to 3 hours (including hydraulic pump)	2 to 3 hours (including hydraulic pump)
Chute Deflector Adjustment (standard)	Manual	Manual
Chute Deflector Adjustment (option)	Hydraulic - cylinder (2"x6") including hoses and tips	Hydraulic - cylinder (2"x8") including hoses and tips
Chute Rotation (standard)	Hydraulic – hydraulic motor with electro-hydraulic valve	Hydraulic – hydraulic motor with electro-hydraulic valve
Chute	Two-part	Two-part
Drift Cutters	Option	Option