

REAR BLADES

RB2272

RB2284

RB2296

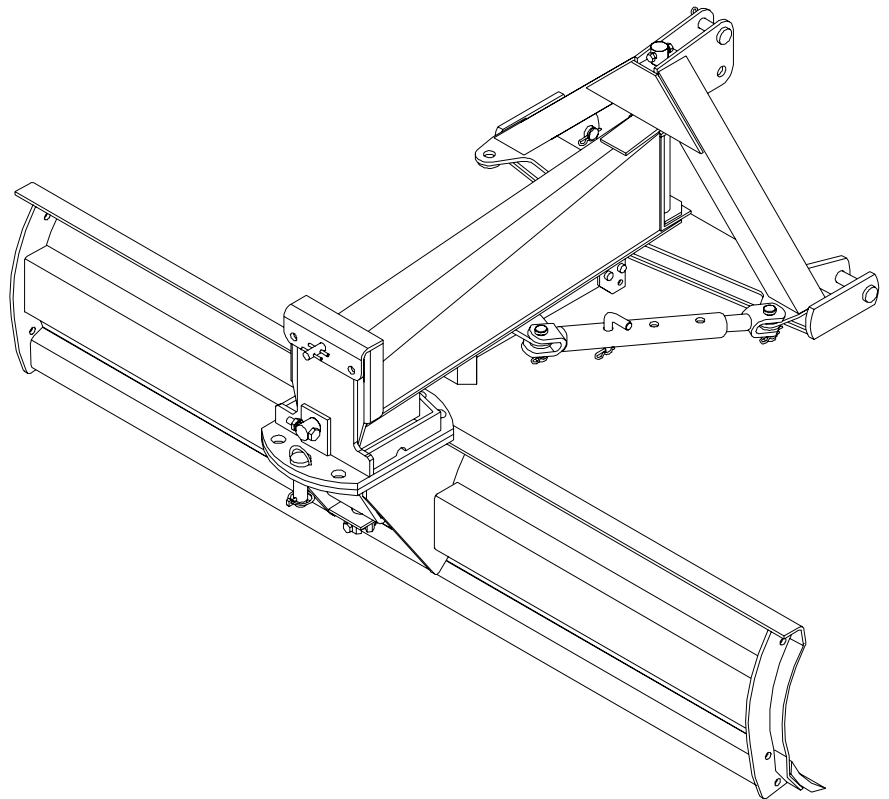

TO THE DEALER:

Assembly and proper installation of this product is the responsibility of the Frontier dealer. Read manual instructions and safety rules. Make sure all items on the Dealer's Pre-delivery and Delivery Check Lists in the Operator's Manual are completed before releasing equipment to the owner.

TO THE OWNER:

Read this manual before operating your Frontier equipment. The information presented will prepare you to do a better and safer job. Keep this manual handy for ready reference. Require all operators to read this manual carefully and become acquainted with all the adjustment and operating procedures before attempting to operate. Replacement manuals can be obtained from your selling dealer.

The equipment you have purchased has been carefully engineered and manufactured to provide dependable and satisfactory use. Like all mechanical products, it will require cleaning and upkeep. Lubricate the unit as specified. Observe all safety information in this manual and safety decals on the equipment.

For service, your authorized Frontier dealer has trained mechanics, genuine Frontier service parts, and the necessary tools and equipment to handle all your needs.

Use only genuine Frontier service parts. Substitute parts will void the warranty and may not meet standards required for safe and satisfactory operation. Record the model number and serial number of your equipment in the spaces provided:

Model: _____ **Date of Purchase:**_____

Serial Number: (see Safety & Instructional Decals section for location)_____

Provide this information to your dealer to obtain correct repair parts.

Throughout this manual, the term **IMPORTANT** is used to indicate that failure to observe can cause damage to equipment. The terms **CAUTION**, **WARNING**, and **DANGER** are used in conjunction with the Safety-alert Symbol, (a triangle with an exclamation mark), to indicate the degree of hazard for items of personal safety.



This Safety-alert Symbol indicates a hazard and means **ATTENTION! BECOME ALERT! YOUR SAFETY IS INVOLVED!**



Indicates an imminently hazardous situation that, if not avoided, will result in death or serious injury.



Indicates a potentially hazardous situation that, if not avoided, could result in death or serious injury, and includes hazards that are exposed when guards are removed.



Indicates a potentially hazardous situation that, if not avoided, may result in minor or moderate injury.

IMPORTANT

Indicates that failure to observe can cause damage to equipment.

NOTE

Indicates helpful information.

TABLE OF CONTENTS

INTRODUCTION	<i>ii</i>
GENERAL INFORMATION	1
SPECIFICATIONS	2
SAFETY RULES	3
SAFETY & INSTRUCTIONAL DECALS	5
OPERATION	7
OWNER SERVICE	13
ASSEMBLY	15
PARTS INDEX	28
BOLT TORQUE CHART	35
BOLT SIZE CHART & ABBREVIATIONS	36

GENERAL INFORMATION

The purpose of this manual is to assist you in operating and maintaining your rear blade. Read it carefully. It furnishes information and instructions that will help you achieve years of dependable performance. These instructions have been compiled from extensive field experience and engineering data. Some information may be general in nature, due to unknown and varying operating conditions. However, through experience and these instructions, you should be able to develop procedures suitable to your particular situation.

The illustrations and data used in this manual were current at the time of printing. However, due to possible inline production changes, your machine may vary slightly in detail. We reserve the right to redesign and change the machines as may be necessary without notification.

Throughout this manual, references are made to right and left direction. These are determined by standing behind the tractor facing the direction of forward travel.

<https://www.ebooklibonline.com>

Hello dear friend!

Thank you very much for reading.

Enter the link into your browser.

The full manual is available for immediate download.

<https://www.ebooklibonline.com>

RB2272 / RB2284 / RB2296 SPECIFICATIONS

Models	RB2272	RB2284	RB2296
Features & Specifications			
Angle, tilt, & offset	Manually adjusted angle, tilt and offset	Manually adjusted angle, tilt and offset	Manually adjusted angle, tilt and offset
Hitch compatibility	Cat. 2 Quick Coupler	Cat. 2 Quick Coupler	Cat. 2 Quick Coupler
Frame	Formed steel channel frame	Formed steel channel frame	Formed steel channel frame
Cutting edge	½" x 6" reversible	½" x 6" reversible	½" x 6" reversible
Angle/Pivot	360 Degrees	360 Degrees	360 Degrees
Angle-Forward	3, up to 45 degrees each side	3, up to 45 degrees each side	3, up to 45 degrees each side
Angle-Reverse	3, up to 45 degrees each side	3, up to 45 degrees each side	3, up to 45 degrees each side
Moldboard thickness	1/4"	1/4"	1/4"
Moldboard length	72"	84"	96"
Moldboard height	19"	19"	19"
Moldboard type	Progressive-formed	Progressive-formed	Progressive-formed
Moldboard upper edge	Full bend	Full bend	Full bend
Offset (or swing)	9" or 18" left or right *	9" or 18" left or right *	9" or 18" left or right *
Tractor max. HP	80HP (2WD) 70HP (4WD)	80HP (2WD) 70HP (4WD)	80HP (2WD) 70HP (4WD)
Tractor hydraulic system pressure	3000 psi Maximum (20.68 MPa)	3000 psi Maximum (20.68 MPa)	3000 psi Maximum (20.68 MPa)
Tilt	3, up to 23 degrees up and down	3, up to 23 degrees up and down	3, up to 23 degrees up and down
Operating weight	738 lbs.	755 lbs.	772 lbs.

* 0" or 19" left or right with optional offset hydraulic kit.

****Tecnomec Agrícola, S.A. de C.V. reserves the right to make any changes deemed necessary to the specifications without prior notice.**



SAFETY RULES

ATTENTION! BECOME ALERT! YOUR SAFETY IS INVOLVED!



Safety is a primary concern in the design and manufacture of our products. Unfortunately, our efforts to provide safe equipment can be wiped out by an operator's single careless act.

In addition to the design and configuration of equipment, hazard control and accident prevention are dependent upon the awareness, concern, judgement, and proper training of personnel involved in the operation, transport, maintenance, and storage of equipment.

It has been said "The best safety device is an informed, careful operator." We ask you to be that kind of operator.

TRAINING

- **Safety instructions are important! Read all attachment and power unit manuals; follow all safety rules and safety decal information. (Replacement manuals are available from your dealer). Failure to follow instructions or safety rules can result in serious injury or death.**
- **If you do not understand any part of this manual and need assistance, see your dealer.**
- **Know your controls and how to stop engine and attachment quickly in an emergency.**
- **Operators must be instructed in and be capable of the safe operation of the equipment, its attachments, and all controls. Do not allow anyone to operate this equipment without proper instructions.**
- **Keep hands and body away from pressurized lines. Use paper or cardboard, not hands or other body parts to check for leaks. Wear safety goggles. Hydraulic fluid under pressure can easily penetrate skin and will cause serious injury or death.**
- **Make sure that all operating and service personnel know that if hydraulic fluid penetrates skin, it must be surgically removed as soon as possible by a doctor familiar with this form of injury or gangrene, serious injury, or death will result. CONTACT A PHYSICIAN IMMEDIATELY IF FLUID ENTERS SKIN OR EYES. DO NOT DELAY.**
- **Never allow children or untrained persons to operate equipment.**

PREPARATION

- **Check that all hardware is properly installed. Always tighten to torque chart specifications unless instructed otherwise in this manual.**
- **Do not connect a low-pressure hydraulic hose into a high-pressure system - it will burst the hose. Do not use a high-pressure hose in place of a low-pressure hose - it is possible to rupture the valve.**
- **Always wear relatively tight and belted clothing to avoid entanglement in moving parts. Wear sturdy, rough-soled work shoes and protective equipment for eyes, hair, hands, hearing, and head.**
- **Make sure attachment is properly secured, adjusted, and in good operating condition.**
- **Power unit must be equipped with ROPS or ROPS cab and seat belt. Keep seat belt securely fastened. Falling off power unit can result in death from being run over or crushed. Keep foldable ROPS systems in "locked up" position at all times.**
- **Make sure all safety decals are installed. Replace if damaged. (See Safety & Instructional Decals section for location).**
- **A minimum 20% of tractor and equipment weight must be on the tractor front wheels when attachments are in transport position. Without this weight, tractor could tip over, causing personal injury or death. The weight may be attained with a loader, front wheel weights, ballast in tires or front tractor weights. Weigh the tractor and equipment. Do not estimate.**
- **Make sure circuit selector lever does not hit tractor cab, etc. throughout operating range of 3-point hitch of tractor. Bend lever, if necessary, to clear cab, but it should still be convenient to operate from the tractor seat.**

OPERATION

- **Do not allow bystanders in the area when operating, attaching, removing, assembling, or servicing equipment.**
- **Do not operate equipment while under the influence of alcohol or drugs.**
- **Operate only in daylight or good artificial light.**
- **Keep hands, feet, hair, and clothing away from equipment while engine is running. Stay clear of all moving parts.**

(Safety Rules continued on next page)



Suggest:

For more complete manuals. Please go to the home page.

<https://www.ebooklibonline.com>

If the above button click is invalid. Please download this document first, and then click the above link to download the complete manual.

Thank you so much for reading



SAFETY RULES



ATTENTION! BECOME ALERT! YOUR SAFETY IS INVOLVED!

(Safety Rules continued from previous page)

- Always comply with all state and local lighting and marking requirements.
- Never allow riders on power unit or attachment.
- Power unit must be equipped with ROPS or ROPS cab and seat belt. Keep seat belt securely fastened. Falling off power unit can result in death from being run over or crushed. Keep foldable ROPS systems in “locked up” position at all times.
- Always sit in power unit seat when operating controls or starting engine. Securely fasten seat belt, place transmission in neutral, engage brake, and ensure all other controls are disengaged before starting power unit engine.
- Look down and to the rear and make sure area is clear before operating in reverse.
- Do not operate on steep slopes.
- Do not stop, start, or change directions suddenly on slopes.
- Use extreme care and reduce ground speed on slopes and rough terrain.
- Watch for hidden hazards on the terrain during operation.
- Stop power unit and equipment immediately upon striking an obstruction. Turn off engine, remove key, inspect, and repair any damage before resuming operation.
- Before changing positions of manual swing, tilt, or angle positions:
 - Park tractor on level ground, apply parking brake, level implement boom, shut off tractor, and remove key.
 - Make manual changes slowly and carefully to prevent hazardous movement of mechanisms.
 - Never stand in positions where you could become entrapped during adjustment changes or if the 3-point hitch suddenly lowers.
- Always secure lock pins with safety pins to prevent lock pins from bumping out of the positioning holes. Failure to do so may result in accidents and/or damage to rear blade.
- Before dismounting power unit or performing any service or maintenance, follow these steps: disengage power to equipment, lower the 3-point hitch and all raised components to the ground, operate valve levers to release any hydraulic pressure, set parking brake, stop engine, remove key, and unfasten seat belt.

- Before working underneath, read manual instructions, securely block up, and check stability. Secure blocking prevents equipment from dropping due to hydraulic leak down, hydraulic system failure, or mechanical component failure.

MAINTENANCE

- Before dismounting power unit or performing any service or maintenance, follow these steps: disengage power to equipment, lower the 3-point hitch and all raised components to the ground, operate valve levers to release any hydraulic pressure, set parking brake, stop engine, remove key, and unfasten seat belt.
 - Before performing any service or maintenance, lower attachment to ground, turn off engine, set parking brake, and remove key.
 - Before working underneath, read manual instructions, securely block up, and check stability. Secure blocking prevents equipment from dropping due to hydraulic leak down, hydraulic system failure, or mechanical component failure.
 - Always wear relatively tight and belted clothing to avoid entanglement in moving parts. Wear sturdy, rough-soled work shoes and protective equipment for eyes, hair, hands, hearing, and head.
 - Do not modify or alter or permit anyone else to modify or alter the equipment or any of its components in any way.
 - Make sure attachment is properly secured, adjusted, and in good operating condition.
 - Never perform service or maintenance with engine running.
 - Keep all persons away from operator control area while performing adjustments, service, or maintenance.
 - Tighten all bolts, nuts and screws to torque chart specifications. Check that all cotter pins are installed securely to ensure equipment is in a safe condition before putting unit into service.
 - Make sure all safety decals are installed. Replace if damaged. (See Safety & Instructional Decals section for location).
 - Do not disconnect hydraulic lines until machine is securely blocked or placed in lowest position and system pressure is released by operating valve levers.
- #### STORAGE
- Secure equipment parking stand(s) in park position before detaching.
 - Keep children and bystanders away from storage area.



SAFETY & INSTRUCTIONAL DECALS

ATTENTION! BECOME ALERT! YOUR SAFETY IS INVOLVED!

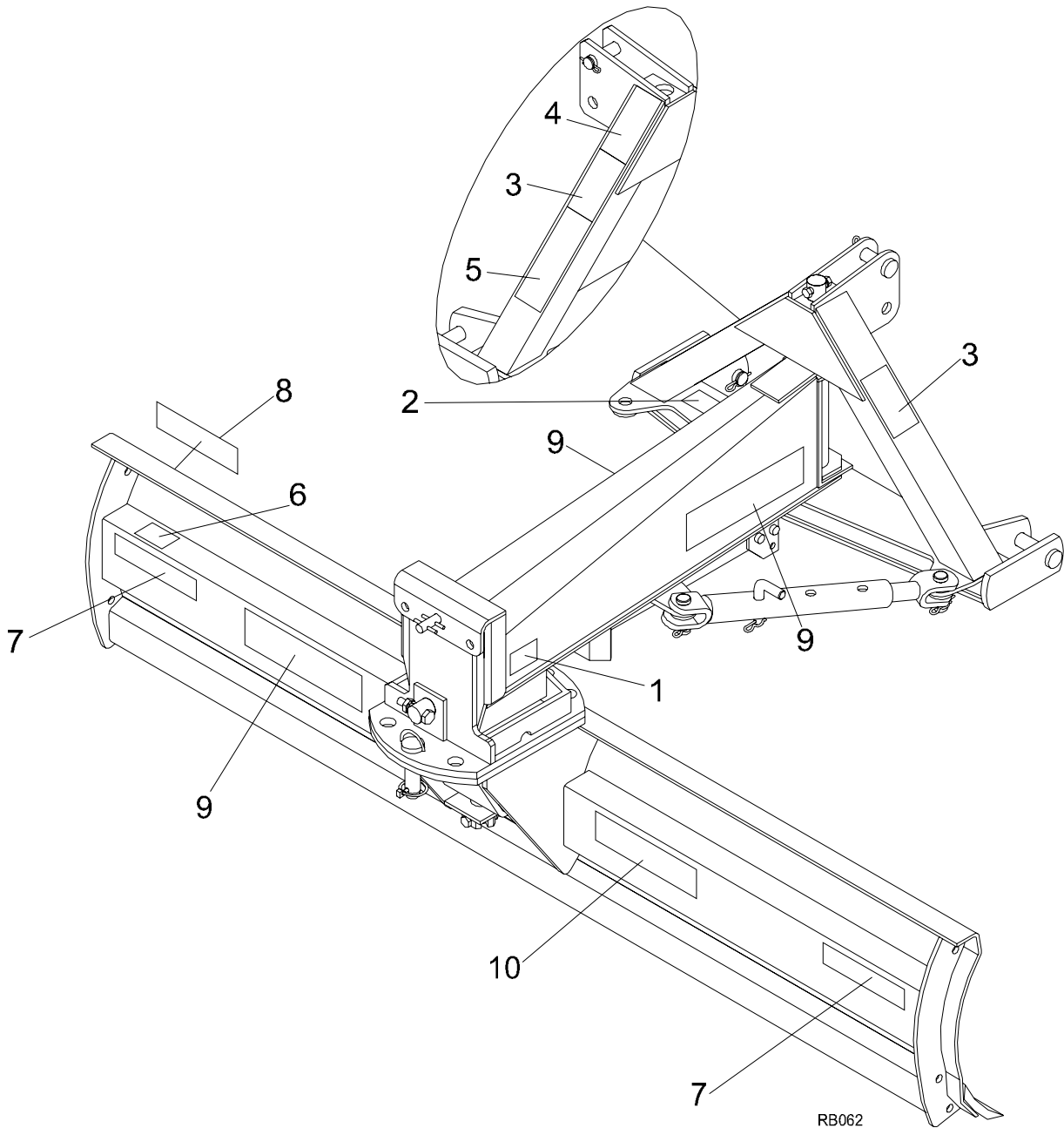

RB062

1.- Serial Number Plate (1)

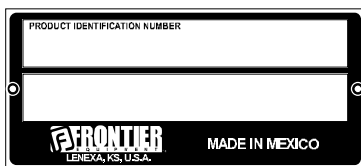

2.- 5TM310707000 (1)* (English)
5TM310708000 (1)** (French)

<p>19924-B</p>	<p>⚠ WARNING</p> <p>HIGH-PRESSURE HYDRAULIC OIL LEAKS CAN PENETRATE SKIN RESULTING IN SERIOUS INJURY, GANGRENE OR DEATH.</p> <ul style="list-style-type: none"> ■ Check for leaks with cardboard; never use hand. ■ Before loosening fittings: lower load, release pressure, and be sure oil is cool. ■ Consult physician immediately if skin penetration occurs.
----------------	--

<https://www.ebooklibonline.com>

Hello dear friend!

Thank you very much for reading.

Enter the link into your browser.

The full manual is available for immediate download.

<https://www.ebooklibonline.com>