

O P E R A T O R ' S M A N U A L

# GROOMING MOWERS

## GM1060S

## GM1072S

**15-Digit Serial Numbers WDGM10XKS233700 & Above, and  
All 13-Digit/17-Digit XF Serial Numbers  
Revision Effective 7/2008**

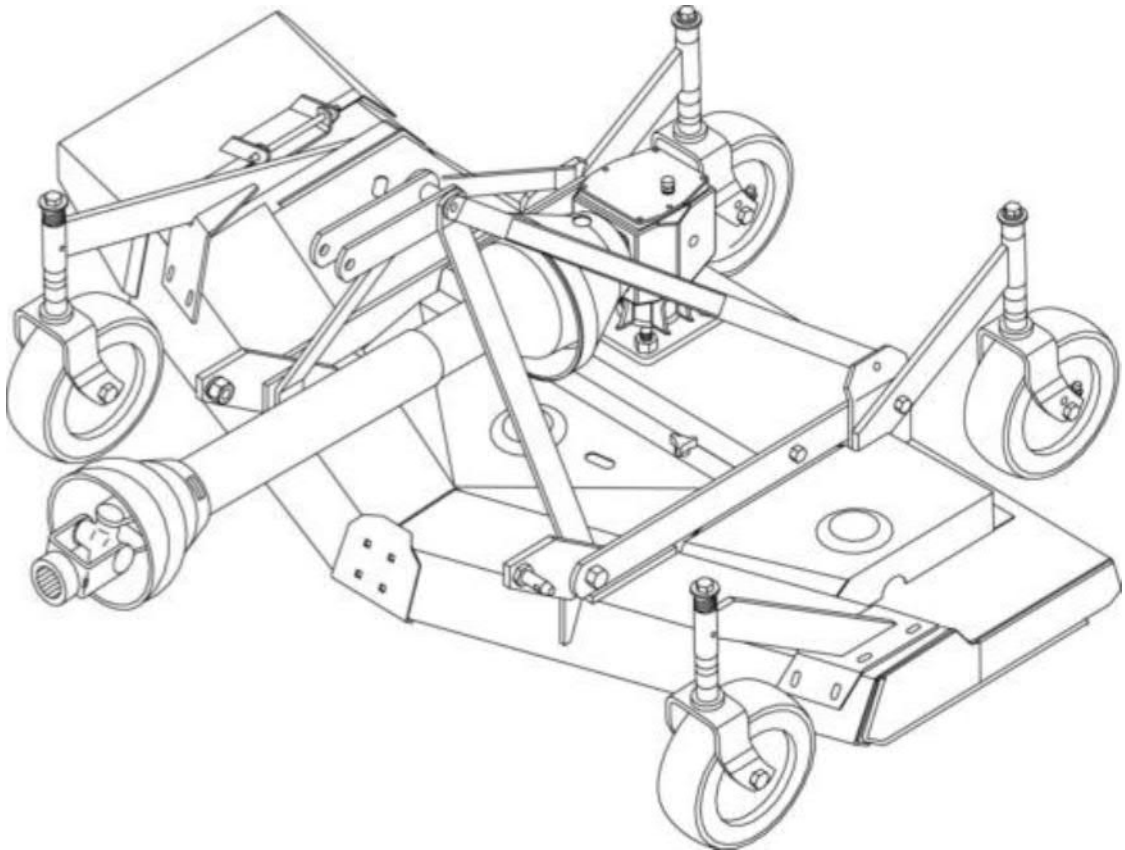

**FRONTIER**  
EQUIPMENT™

# TABLE OF CONTENTS

INTRODUCTION .....	2
SPECIFICATIONS .....	4
GENERAL INFORMATION .....	4
SAFETY RULES .....	5-6
SAFETY DECALS .....	7-8
OPERATION .....	9
OWNER SERVICE .....	13
TROUBLESHOOTING .....	18
DEALER SERVICE .....	20
ASSEMBLY .....	28
DEALER CHECK LISTS .....	32
PARTS INDEX .....	33
BOLT TORQUE CHART .....	46
BOLT SIZE CHART & ABBREVIATIONS .....	47
INDEX .....	48
PRODUCT WARRANTY .....	50
REPLACEMENT PARTS WARRANTY .....	INSIDE BACK COVER

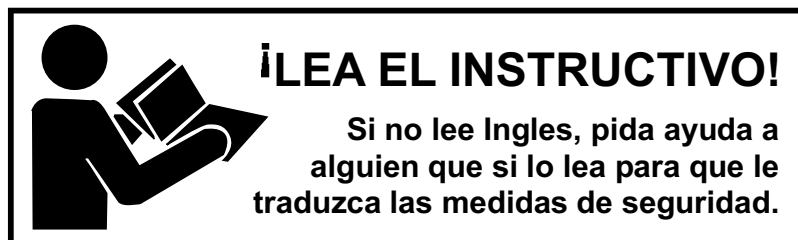

This Operator's Manual should be regarded as part of the machine. Suppliers of both new and second-hand machines must make sure that this manual is provided with the machine.

# SPECIFICATIONS

	<u>GM1060</u>	<u>GM1072</u>
3-Point Hitch	Category 1	Category 1
Cutting Width	60" (1524 mm)	72" (1829 mm)
Cutting Height Range	1.5" - 6" (38 - 152 mm)	1.5" - 6" (38 - 152 mm)
Shipping Weight (Approximate)	500 lbs (226.8 kg)	550 lbs (249.5 kg)
Blade Speed (feet per minute)	15,200	16,600
Blade Speed (RPM)	2,795	2,571
Blade Spindles	3	3
Number of Blades	3	3
Universal Drive Series	Category 3	Category 3
Caster Wheels	3.5" x 10.25" (89 - 260 mm)	3.5" x 10.25" (89 - 260 mm)
Tractor PTO Speed RPM	540	540
Recommended Maximum Tractor Horsepower	35	35
Mower Frame Thickness	8 GA	8 GA

---

## GENERAL INFORMATION

 **WARNING**

■ **Some illustrations in this manual show the equipment with safety shields removed to provide a better view. This equipment should never be operated with any necessary safety shielding removed.**

The purpose of this manual is to assist you in operating and maintaining your mower. Read it carefully. It furnishes information and instructions that will help you achieve years of dependable performance. These instructions have been compiled from extensive field experience and engineering data. Some information

may be general in nature, due to unknown and varying operating conditions. However, through experience and these instructions, you should be able to develop procedures suitable to your particular situation.

The illustrations and data used in this manual were current at the time of printing. However, due to possible inline production changes, your machine may vary slightly in detail. We reserve the right to redesign and change the machines as may be necessary without notification.

Throughout this manual, references are made to right and left directions. These are determined by standing behind the tractor facing the direction of forward travel.

## 4 Introduction

5WPMAN0242 (Rev. 7/21/2008)

**<https://www.ebooklibonline.com>**

Hello dear friend!

Thank you very much for reading.

Enter the link into your browser.

The full manual is available for immediate download.

**<https://www.ebooklibonline.com>**

# SAFETY RULES



**ATTENTION! BECOME ALERT! YOUR SAFETY IS INVOLVED!**



Safety is a primary concern in the design and manufacture of our products. Unfortunately, our efforts to provide safe equipment can be wiped out by an operator's single careless act.

In addition to the design and configuration of equipment, hazard control and accident prevention are dependent upon the awareness, concern, judgement, and proper training of personnel involved in the operation, transport, maintenance and storage of equipment.

It has been said "The best safety device is an informed, careful operator." We ask you to be that kind of operator.

## **TRAINING**

- **Safety instructions are important! Read all attachment and power unit manuals; follow all safety rules and safety decal information. (Replacement manuals and safety decals are available from your dealer.) Failure to follow instructions or safety rules can result in serious injury or death.**
- **If you do not understand any part of this manual and need assistance, see your dealer.**
- **Know your controls and how to stop engine and attachment quickly in an emergency.**
- **Operators must be instructed in and be capable of the safe operation of the equipment, its attachments, and all controls. Do not allow anyone to operate this equipment without proper instructions.**
- **Never allow children or untrained persons to operate equipment.**

## **PREPARATION**

- **Check that all hardware is properly installed. Always tighten to torque chart specifications unless instructed otherwise in this manual.**
- **Always wear relatively tight and belted clothing to avoid getting caught in moving parts. Wear sturdy, rough-soled work shoes and protective equipment for eyes, hair, hands, hearing, and head; and respirator or filter mask where appropriate.**
- **Make sure attachment is properly secured, adjusted, and in good operating condition.**
- **Make sure spring-activated locking pin or collar slides freely and is seated firmly in tractor PTO spline groove.**
- **Power unit must be equipped with ROPS or ROPS cab and seat belt. Keep seat belt securely fastened. Falling off power unit can result in death**

from being run over or crushed. Keep foldable ROPS system in "locked up" position at all times.

- **Remove accumulated debris from this equipment, power unit, and engine to avoid fire hazard.**
- **Make sure all safety decals are installed. Replace if damaged. (See Safety Decals section for location.)**
- **Make sure shields and guards are properly installed and in good condition. Replace if damaged.**
- **A minimum 20% of tractor and equipment weight must be on the tractor front wheels when attachments are in transport position. Without this weight, tractor could tip over, causing personal injury or death. The weight may be attained with a loader, front wheel weights, ballast in tires or front tractor weights. Weigh the tractor and equipment. Do not estimate.**
- **Inspect and clear area of stones, branches, or other hard objects that might be thrown, causing injury or damage.**

## **OPERATION**

- **Do not put mower into service unless discharge chute is installed and in good condition. Replace if damaged.**
- **Keep bystanders away from equipment.**
- **Never direct discharge toward people, animals, or property.**
- **Do not operate or transport equipment while under the influence of alcohol or drugs.**
- **Operate only in daylight or good artificial light.**
- **Keep hands, feet, hair, and clothing away from equipment while engine is running. Stay clear of all moving parts.**
- **Always comply with all state and local lighting and marking requirements.**
- **Never allow riders on power unit or attachment.**
- **Power unit must be equipped with ROPS or ROPS cab and seat belt. Keep seat belt securely fastened. Falling off power unit can result in death from being run over or crushed. Keep foldable ROPS system in "locked up" position at all times.**
- **Always sit in power unit seat when operating controls or starting engine. Securely fasten seat belt, place transmission in neutral, engage brake, and ensure all other controls are disengaged before starting power unit engine.**

*(Safety Rules continued on next page)*

# SAFETY RULES



**ATTENTION! BECOME ALERT! YOUR SAFETY IS INVOLVED!**



*(Safety Rules continued from previous page)*

- Operate tractor PTO at 540 RPM. Do not exceed.
- Look down and to the rear and make sure area is clear before operating in reverse.
- Do not operate or transport on steep slopes.
- Do not stop, start, or change directions suddenly on slopes.
- Use extreme care and reduce ground speed on slopes and rough terrain.
- Watch for hidden hazards on the terrain during operation.
- Stop power unit and equipment immediately upon striking an obstruction. Turn off engine, remove key, inspect, and repair any damage before resuming operation.

## TRANSPORTATION

- Power unit must be equipped with ROPS or ROPS cab and seat belt. Keep seat belt securely fastened. Falling off power unit can result in death from being run over or crushed. Keep foldable ROPS system in “locked up” position at all times.
- Always comply with all state and local lighting and marking requirements.
- Never allow riders on power unit or attachment.
- Do not operate PTO during transport.
- Look down and to the rear and make sure area is clear before operating in reverse.
- Do not operate or transport on steep slopes.
- Do not operate or transport equipment while under the influence of alcohol or drugs.

## MAINTENANCE

- Before performing any service or maintenance, lower equipment to ground or block securely, turn off engine, remove key, and disconnect driveline from tractor PTO.
- Do not modify or alter or permit anyone else to modify or alter the equipment or any of its components in any way.
- Always wear relatively tight and belted clothing to avoid getting caught in moving parts. Wear

sturdy, rough-soled work shoes and protective equipment for eyes, hair, hands, hearing, and head; and respirator or filter mask where appropriate.

- Keep all persons away from operator control area while performing adjustments, service, or maintenance.
- Make certain all movement of equipment components has stopped before approaching for service.
- Frequently check blades. They should be sharp, free of nicks and cracks, and securely fastened.
- Use a new Nylok blade bolt and cup washers when you replace the blade. Do not substitute any bolt for the special blade bolt. It is self-locking, meeting the non-loosening requirements for this application.

■ Do not handle blades with bare hands. Careless or improper handling may result in serious injury.

■ Your dealer can supply genuine replacement blades. Substitute blades may not meet original equipment specifications and may be dangerous.

■ Tighten all bolts, nuts, and screws to torque chart specifications. Check that all cotter pins are installed securely to ensure equipment is in a safe condition before putting unit into service.

■ Make sure all safety decals are installed. Replace if damaged. (See Safety Decals section for location.)

■ Make sure shields and guards are properly installed and in good condition. Replace if damaged.

## STORAGE

- Block equipment securely for storage.
- Keep children and bystanders away from storage area.
- Follow manual instructions for storage.





# SAFETY & INSTRUCTIONAL DECALS

**ATTENTION! BECOME ALERT! YOUR SAFETY IS INVOLVED!**  
**Replace Immediately If Damaged!**

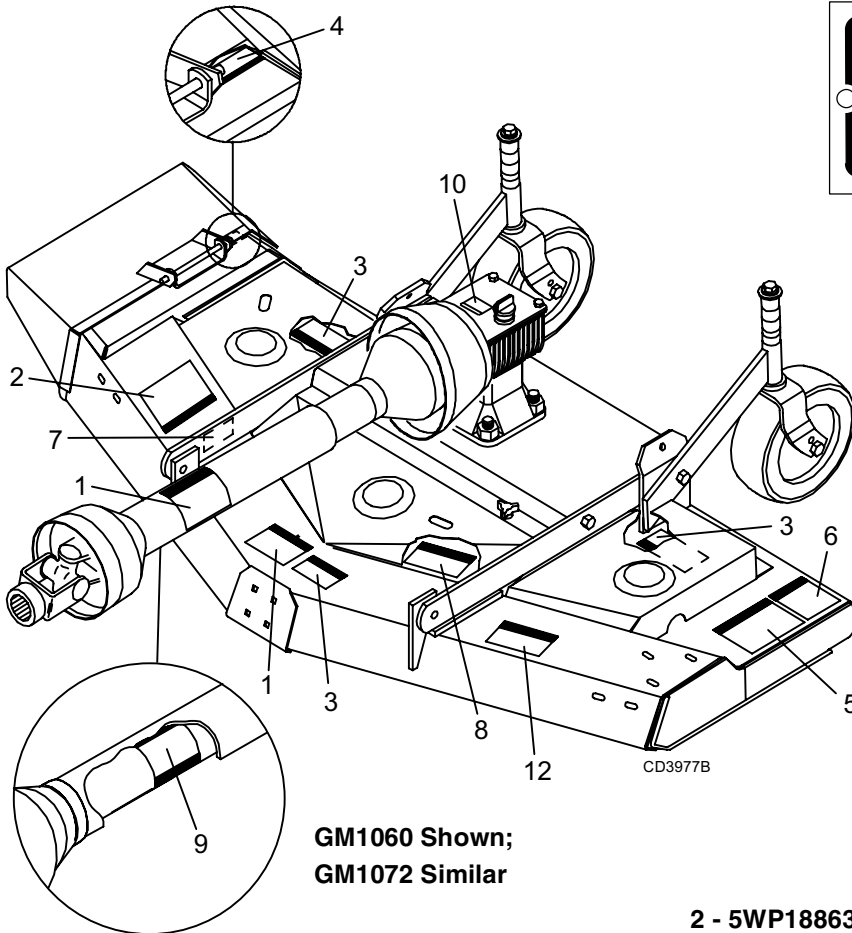

GM1060 Shown;  
GM1072 Similar

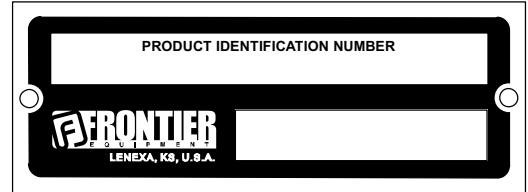

7 - Serial Number Plate

9 - 5WP33347



2 - 5WP18863



1 - 5WP18864



(Safety Decals continued on next page)



**Suggest:**

**For more complete manuals. Please go to the home page.**

**<https://www.ebooklibonline.com>**

**If the above button click is invalid. Please download this document first, and then click the above link to download the complete manual.**

**Thank you so much for reading**



# SAFETY & INSTRUCTIONAL DECALS

**ATTENTION! BECOME ALERT! YOUR SAFETY IS INVOLVED!**



**Replace Immediately If Damaged!**

(Safety Decals continued from previous page)

**⚠ DANGER**

**SHIELD MISSING**

DO NOT OPERATE  
PUT SHIELD ON

18867-B

3 - 5WP18867

4 - 5WP18869

**⚠ DANGER**

**SHIELD MISSING**

DO NOT OPERATE - PUT SHIELD ON

18869-B

5 - 5WP18865

**⚠ WARNING**

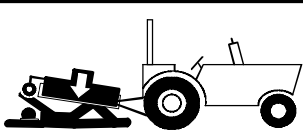
**FALLING OFF CAN RESULT IN BEING RUN OVER.**

- Tractor must be equipped with ROPS (or ROPS CAB) and seat belt. Keep foldable ROPS systems in "locked up" position at all times.
- Buckle Up! Keep seat belt securely fastened.
- Allow no riders.

**RAISED EQUIPMENT CAN DROP AND CRUSH.**

- Before working underneath, follow all instructions and safety rules in operator's manual and securely block up all corners of equipment with jack stands.
- Securely blocking prevents equipment dropping from hydraulic leak-down, hydraulic system failures or mechanical component failures.

**FALLING OFF OR FAILING TO BLOCK SECURELY CAN RESULT IN SERIOUS INJURY OR DEATH.**

18865-C

6 - 5WP18877

**⚠ WARNING**

**TO AVOID SERIOUS INJURY OR DEATH:**

- Read Operator's Manual (available from dealer) and follow all safety precautions.
- Keep all shields in place and in good condition.
- Operate mower from tractor seat only.
- Lower mower, stop engine and remove key before dismounting tractor.
- Allow no children or untrained persons to operate equipment.
- Do not transport towed or semi-mounted units over 20 mph.

**FAILURE TO OPERATE SAFELY CAN RESULT IN INJURY OR DEATH.**

18877-C

8 - 5WP18866

**⚠ WARNING**

**DO NOT EXCEED PTO SPEED OF 540 RPM**

PTO speeds higher than 540 RPM can cause equipment failure and personal injury.

18866-D

12 - 5WP1003751

**⚠ WARNING**





**CRUSHING AND PINCHING HAZARD**

- Be extremely careful handling various parts of the machine. They are heavy and hands, fingers, feet, and other body parts could be crushed or pinched between tractor and implement.
- Operate tractor controls from tractor seat only.
- Do not stand between tractor and implement when tractor is in gear.
- Make sure parking brake is engaged before going between tractor and implement.
- Stand clear of machine while in operation or when it is being raised or lowered.

**FAILURE TO FOLLOW THESE INSTRUCTIONS COULD RESULT IN SERIOUS INJURY OR DEATH.**

1003751-A

10 - 5WP1004114

**⚠ DANGER**

If shaft connection is visible, shield is missing. Replace shield before operating equipment.

1004114

## BE CAREFUL!

Use a clean, damp cloth to clean safety decals.

Avoid spraying too close to decals when using a pressure washer; high-pressure water can enter through very small scratches or under edges of decals causing them to peel or come off.

Replacement safety decals can be ordered free from your dealer.

# OPERATION

The operator is responsible for the safe operation of the mower. The operator must be properly trained. Operators should be familiar with the mower, tractor, and all safety practices before starting operation. Read the safety rules and safety decals on pages 5 to 8.

This mower is designed for lawn and grass mowing. It is not designed for rough conditions or heavy weed mowing. It is equipped with suction type blades for best results in lawn mowing.

Recommended mowing speed for most conditions is from 2 to 5 mph.

## WARNING

- Never allow children or untrained persons to operate equipment.
- Keep bystanders away from equipment.
- Make sure spring-activated locking pin or collar slides freely and is seated firmly in tractor PTO spline groove.
- Operate tractor PTO at 540 RPM. Do not exceed.

## CAUTION

- Stop power unit and implement immediately upon striking an obstruction. Dismount power unit, using proper procedure. Inspect and repair any damage before resuming operation.
- Always wear relatively tight and belted clothing to avoid getting caught in moving parts. Wear sturdy, rough-soled work shoes and protective equipment for eyes, hair, hands, hearing, and head; and respirator or filter mask where appropriate.

## TRACTOR STABILITY

### WARNING

- A minimum 20% of tractor and equipment weight must be on the tractor front wheels when attachments are in transport position. Without this weight, tractor could tip over, causing personal injury or death. The weight may be attained with a loader, front wheel weights, ballast in tires or front tractor weights. Weigh the tractor and equipment. Do not estimate.

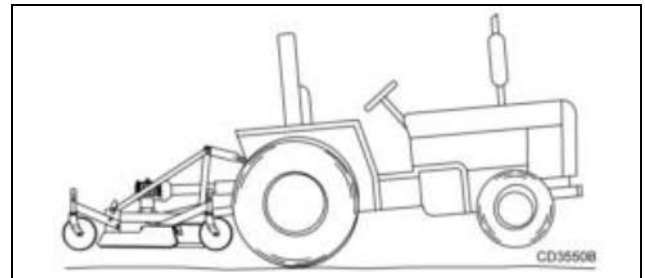

Figure 1. Tractor Stability

## ATTACHING MOWER TO TRACTOR

### WARNING

- Make sure spring-activated locking pin or collar slides freely and is seated firmly in tractor PTO spline groove.

The standard 1-3/8" 6-spline driveline with a QD yoke is used to connect the mower to the tractor.

1. Attach the mower hitch pins to the lower tractor lift arms and secure.
2. Attach tractor top link (1), Figure 2, to mower top link bracket attachment point A. Connect the driveline to the tractor PTO shaft.
3. Attach tether chain to tractor drawbar (Figure 3).
4. Adjust the tractor lower 3-point arm anti-sway devices to prevent mower from swinging side to side during transport.

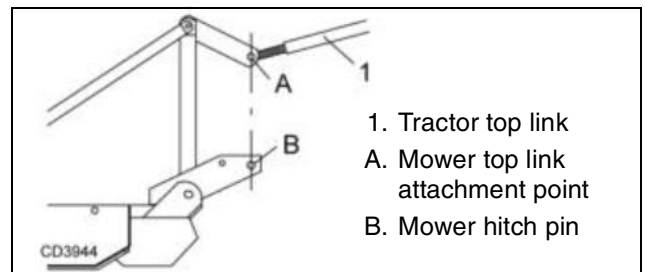

Figure 2. Attachment Points

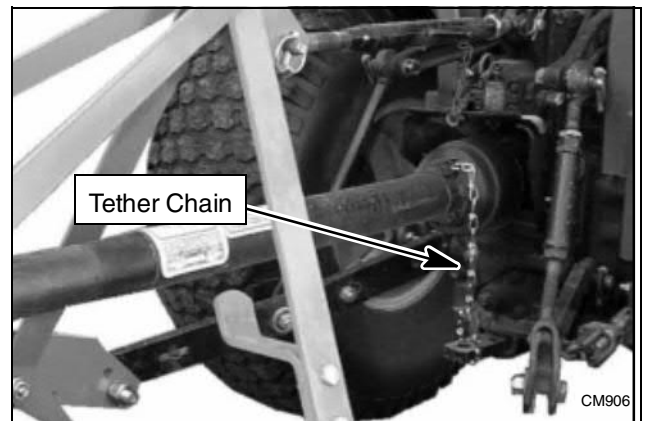

Figure 3. Attaching Mower to Tractor

**<https://www.ebooklibonline.com>**

Hello dear friend!

Thank you very much for reading.

Enter the link into your browser.

The full manual is available for immediate download.

**<https://www.ebooklibonline.com>**