

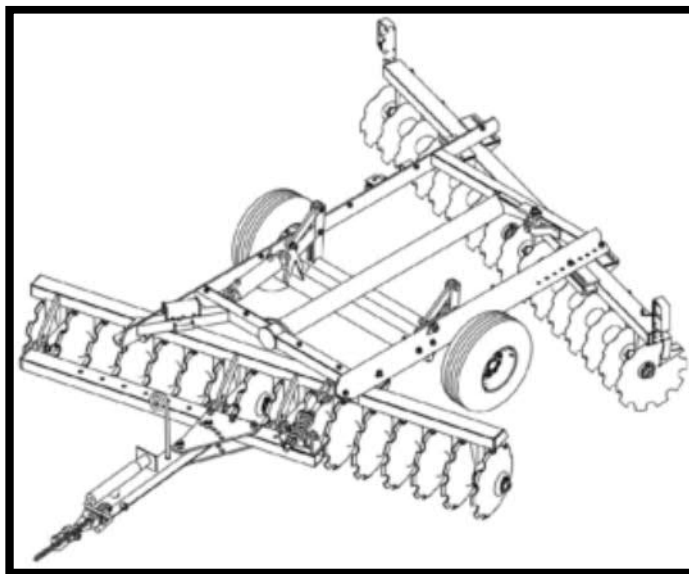

## ASSEMBLY AND OPERATING INSTRUCTIONS



### FRONTIER MODELS DH4108, DH4110, AND DH4114 WHEEL-TYPE OFFSET DISK HARROWS

FORM NO. 5RPMAN293AO

PUBLISHED DATE: 06-08

## Introduction

READ THIS MANUAL carefully to learn how to operate and service your machine correctly. Failure to do so could result in personal injury or equipment damage. This manual and safety signs on your machine may be ordered from your Frontier dealer.

THIS MANUAL SHOULD BE CONSIDERED a permanent part of your machine and should remain with the machine when you sell it.

MEASUREMENTS in this manual are given in customary U.S. units. Use only correct replacement parts and fasteners.

RIGHT-HAND AND LEFT-HAND sides are determined by facing in the direction the implement will travel when going forward.

WRITE DOWN PRODUCT IDENTIFICATION NUMBERS. Accurately record all the numbers to help in tracing the machine should it be stolen. Your Frontier dealer also needs these numbers when you order parts. File the identification numbers in a secure place off the machine.

WARRANTY is provided as a part of Frontier's support program for customers who operate and maintain their equipment as described in this manual. The warranty is explained on the warranty pages that are included in this manual.

This warranty provides you the assurance that Frontier will back its products where defects appear within the warranty period. In some circumstances, Frontier also provides field improvements, often without charge to the customer, even if the product is out of warranty. Should the equipment be abused or modified to change its performance beyond the original factory specifications, the warranty will become void and field improvements may be denied. Setting fuel delivery above specifications or otherwise overpowering machines will result in such action.

## Contents

<b>PRODUCT IDENTIFICATION</b> .....	<b>7</b>
<b>GENERAL INFORMATION</b> .....	<b>8</b>
<b>CHECKLISTS</b> .....	<b>9</b>
PREDELIVERY CHECKLIST .....	9
DELIVERY CHECKLIST .....	10
AFTER-SALE CHECKLIST .....	11
EACH MORNING OF OPERATION CHECKLIST .....	11
BEFORE EACH SEASON CHECKLIST .....	11
<b>SAFETY SIGNS</b> .....	<b>12</b>
<b>SAFETY</b> .....	<b>14</b>
RECOGNIZE SAFETY INFORMATION .....	14
UNDERSTAND SIGNAL WORDS .....	14
FOLLOW SAFETY INSTRUCTIONS.....	14
USE SEAT BELT PROPERLY .....	15
OPERATE SAFELY .....	15
KEEP RIDERS OFF MACHINE .....	16
PREPARE FOR EMERGENCIES.....	16
WEAR PROTECTIVE CLOTHING.....	16
PROTECT AGAINST NOISE.....	16
USE SAFETY LIGHTS AND DEVICES .....	17
USE A SAFETY CHAIN.....	17
TRANSPORT SAFELY .....	18
TOW LOADS SAFELY .....	19
PRACTICE SAFE MAINTENANCE .....	20
REMOVE PAINT BEFORE WELDING OR HEATING .....	21
AVOID HEATING NEAR PRESSURIZED FLUID LINES.....	21
AVOID HIGH-PRESSURE FLUIDS .....	22
AVOID HARMFUL ASBESTOS DUST .....	22
STORE ATTACHMENTS SAFELY.....	23
DISPOSE OF WASTE PROPERLY.....	23
<b>PREPARING THE TRACTOR</b> .....	<b>24</b>
POSITIONING DRAWBAR.....	24

**<https://www.ebooklibonline.com>**

Hello dear friend!

Thank you very much for reading.

Enter the link into your browser.

The full manual is available for immediate download.

**<https://www.ebooklibonline.com>**

## Contents

<b>PREPARING THE DISK .....</b>	<b>25</b>
CHECKING AND LUBRICATING DISK.....	25
ADJUSTING RIGID SCRAPERS.....	25
NOTES .....	26
<b>ATTACHING AND DETACHING .....</b>	<b>27</b>
ATTACHING DISK TO TRACTOR .....	27
ATTACHING SAFETY CHAIN TO TRACTOR.....	27
ATTACHING HYDRAULIC HOSES.....	28
ATTACHING WARNING LIGHT PLUG .....	28
DETACHING DISK FROM TRACTOR .....	29
CHECKING TRANSPORT CONTROL .....	30
CHECKING LEVELING ADJUSTMENT .....	31
NOTES .....	32
<b>TRANSPORTING MACHINE.....</b>	<b>33</b>
CAUTION: SAFETY GUIDELINES .....	33
POSITIONING TRACTOR DRAWBAR FOR TRANSPORT (FOUR WHEEL DRIVE TRACTORS).....	34
POSITIONING JACK FOR TRANSPORT .....	34
ATTACH SAFETY CHAIN TO TRACTOR.....	34
INSTALL TRANSPORT LOCK .....	35
ATTACHING WARNING LIGHT PLUG .....	35
TRANSPORTING THE MACHINE.....	35
<b>OPERATING THE MACHINE.....</b>	<b>36</b>
CAUTION: SAFETY GUIDELINES .....	36
GUIDELINES FOR USE .....	37
TIGHTEN HARDWARE .....	37
OPERATING SPEED .....	37
HYDRAULIC CONTROL .....	38
SCRAPER ADJUSTMENT .....	38
PREPARING TO OPERATE IN FIELD .....	39
SET DEPTH OF PENETRATION CONTROL.....	39
ANGLING FRONT AND REAR GANGS .....	40
REAR GANG SIDE ADJUSTMENT .....	41

## Contents

TORSION BAR ADJUSTMENT .....	42
OFFSET BAR HEIGHT ADJUSTMENT.....	42
LEVELING FRONT TO REAR.....	42
POSITIONING THE DRAWBAR ON OFFSET BAR TO REDUCE TRACTOR SIDE DRAFT .	43
ADJUSTING SIDE DRAFT .....	44
ADJUSTING UNEVEN GANG PENETRATION .....	45
SET DRAWBAR ANGLE .....	46
<b>LUBRICATION .....</b>	<b>47</b>
LUBRICANT STORAGE.....	47
LUBRICATE GANG BEARINGS.....	47
LUBRICATE WHEEL BEARINGS .....	47
LUBRICATE BELL CRANK BEARINGS.....	47
LUBRICATE LEVELING ADJUSTMENT SPRING .....	47
<b>MAINTENANCE.....</b>	<b>48</b>
CAUTION: SAFETY GUIDELINES .....	48
CHECKING WHEEL BOLTS AND BEARINGS .....	49
REPACK WHEEL HUB BEARINGS ANNUALLY .....	49
GANG BEARINGS.....	50
DISK GANGS .....	50
HYDRAULIC HOSES .....	51
FASTENERS .....	51
BLEEDING TRANSPORT CYLINDER .....	52
SERVICING DISK GANGS.....	53
ASSEMBLING DISK SPACERS.....	53
GANG AXLE NUT WRENCHES.....	53
TIGHTEN GANG AXLE NUTS .....	54
ATTACHING DISK GANGS TO STANDARDS.....	55
SERVICE TIRES SAFELY.....	56
CHECKING TIRE PRESSURE .....	56
TIRE PRESSURE CHART .....	57
<b>STORAGE .....</b>	<b>58</b>
BEGINNING OF SEASON MAINTENANCE.....	58
END OF SEASON MAINTENANCE .....	58



**Suggest:**

**For more complete manuals. Please go to the home page.**

**<https://www.ebooklibonline.com>**

**If the above button click is invalid. Please download this document first, and then click the above link to download the complete manual.**

**Thank you so much for reading**

## Contents

<b>ASSEMBLY .....</b>	<b>59</b>
CAUTION: SAFETY GUIDELINES .....	59
CHECK ALL PARTS ON PACKING LIST .....	60
STEP 1. ASSEMBLING GANGS .....	60
STEP 1. ASSEMBLING GANGS .....	61
STEP 2. INSTALLING GANGS ON GANG CARRIERS .....	62
STEP 3. INSTALLING GANG CARRIERS TO FRAME .....	62
STEP 4. INSTALLING TRANSPORT ASSEMBLY .....	62
STEP 5. INSTALLING WHEEL ASSEMBLIES .....	63
STEP 6. INSTALLING OFFSET BAR AND LEVELING SPRING ROD .....	63
STEP 7. INSTALLING DRAWBAR .....	63
STEP 8. ATTACH JACK ASSEMBLY .....	64
STEP 9. ADJUSTING THE SCRAPERS .....	64
STEP 10. INSTALLING HYDRAULIC CONTROL GROUPS .....	64
<b>ATTACHMENT ASSEMBLY .....</b>	<b>65</b>
GENERAL .....	65
INSTALL SAFETY CHAIN .....	65
BEARING WEAR PLATES .....	65
INSTALL WARNING LIGHTS (Model DH4114).....	66
<b>SUGGESTED REPAIR PARTS (DH4108).....</b>	<b>67</b>
<b>SPECIFICATIONS - GENERAL PURPOSE OFFSET DISK MODELS DH4108, DH4110 AND DH4114 .....</b>	<b>70</b>

# Contents

## PRODUCT IDENTIFICATION

### Frontier Model DH4108, DH4110, AND DH4114 Wheel Type Offset Disk Harrow

- A-SAFETY CHAIN
- B-CLEVIS
- C-JACK STAND
- D-OFFSET BAR
- E-FRONT GANG CARRIER
- F-FRAME
- G-HYDRAULIC CYLINDER
- H-TRANSPORT
- I-REAR GANG CARRIER
- J-TORSION BAR
- K-REAR SCRAPER
- L-REAR GANG ASSEMBLY
- M-TIRE & HUB ASSEMBLY
- N-FRONT GANG ASSEMBLY
- O-DISK SPACER
- P-SPRING LEVELER
- Q-DRAWBAR PLATE
- R-HOSE HOLDER
- S-DRAWBAR

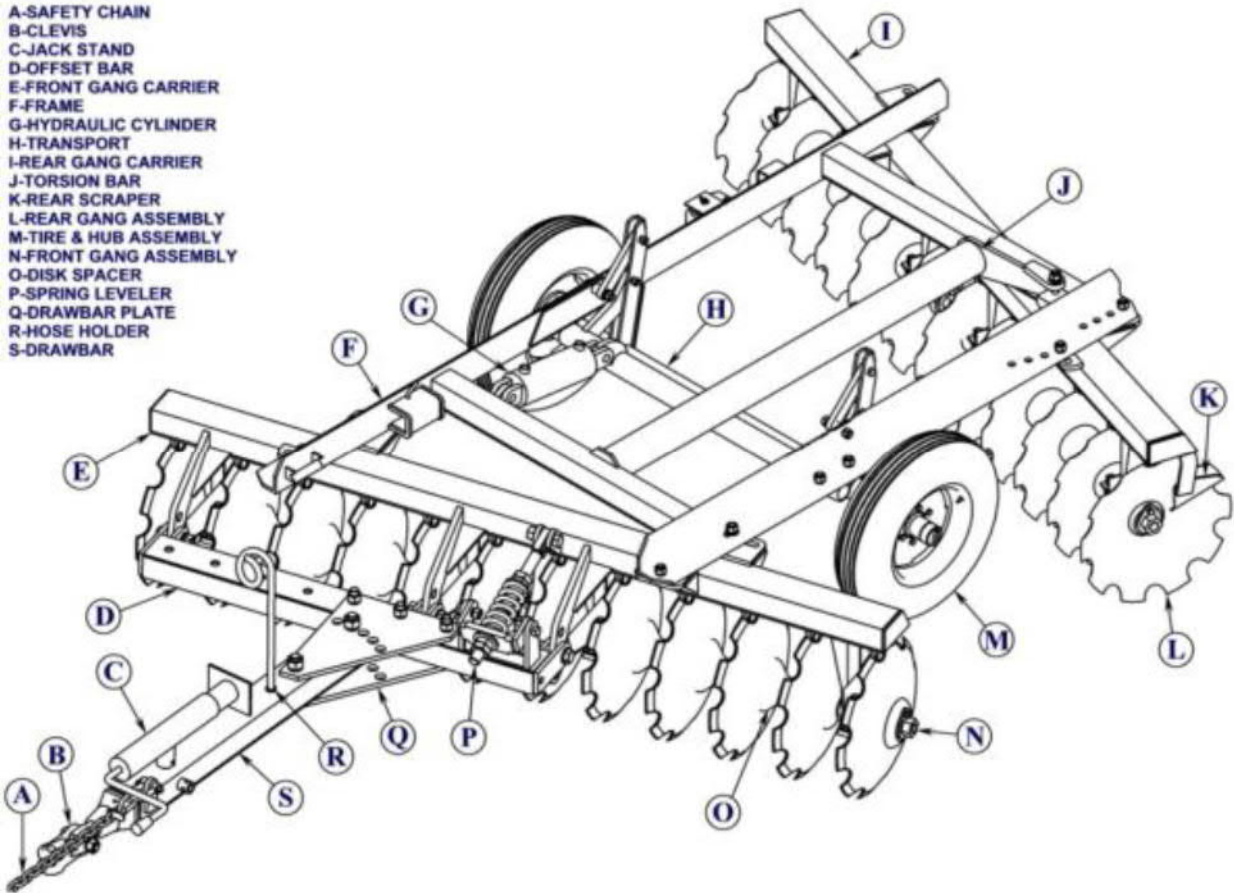

**<https://www.ebooklibonline.com>**

Hello dear friend!

Thank you very much for reading.

Enter the link into your browser.

The full manual is available for immediate download.

**<https://www.ebooklibonline.com>**