

OWNER'S / OPERATOR'S MANUAL

3 PT. HITCH BALE UNROLLER

BU1060

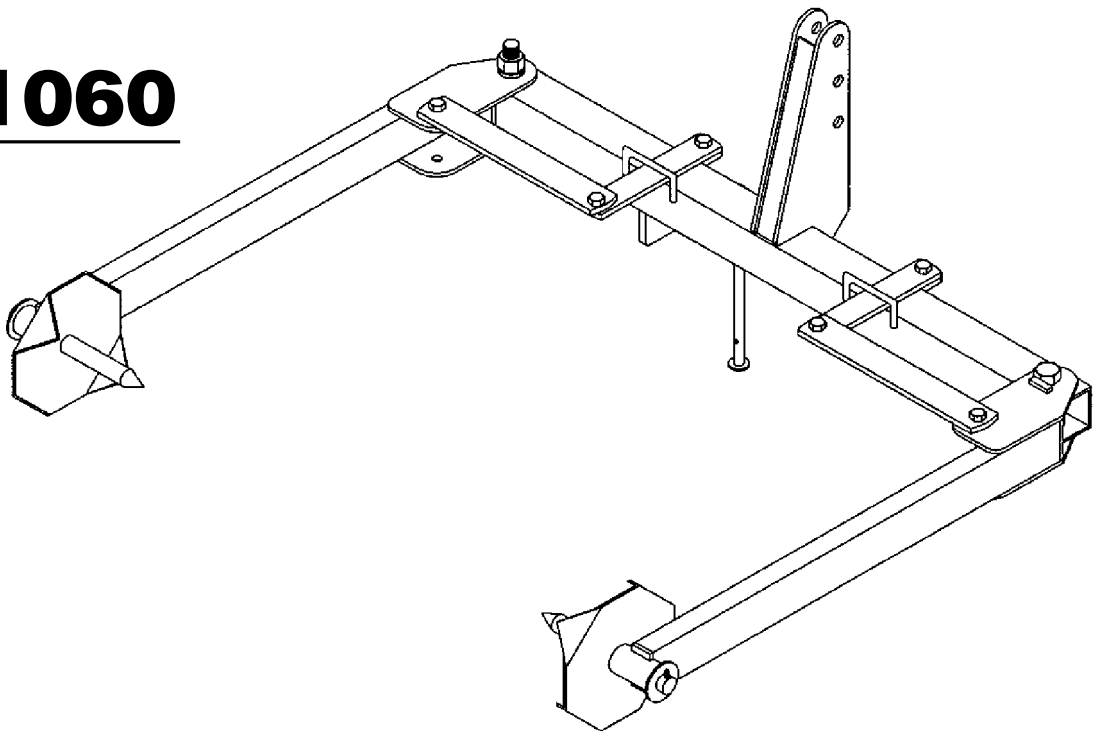

FRONTIER
EQUIPMENT™



Suggest:

For more complete manuals. Please go to the home page.

<https://www.ebooklibonline.com>

If the above button click is invalid. Please download this document first, and then click the above link to download the complete manual.

Thank you so much for reading

TABLE OF CONTENTS

INTRODUCTION.....	ii - 1
SPECIFICATIONS	2
GENERAL INFORMATION	2
SAFETY RULES.....	3 - 4
SAFETY DECALS	5
DEALER ASSEMBLY.....	6
DEALER CHECK LISTS	7
OPERATION.....	8 - 11
OWNER SERVICE.....	12
STORAGE	12
TROUBLE-SHOOTING	13
PARTS LISTS.....	14 - 15
BOLT TORQUE CHART.....	16
BOLT SIZE CHART & ABBREVIATIONS.....	17
REPLACEMENT PARTS WARRANTY	18
PRODUCT WARRANTY.....	19

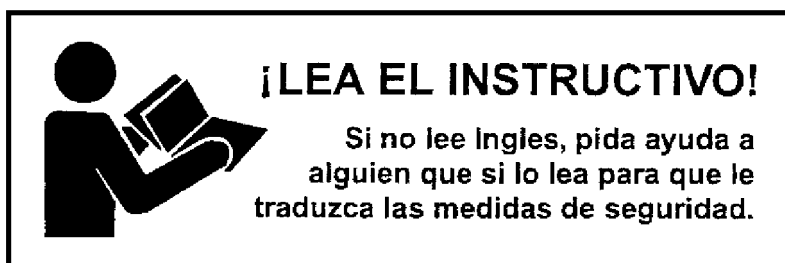

1 *Introduction*

<https://www.ebooklibonline.com>

Hello dear friend!

Thank you very much for reading.

Enter the link into your browser.

The full manual is available for immediate download.

<https://www.ebooklibonline.com>

<https://www.ebooklibonline.com>

Hello dear friend!

Thank you very much for reading.

Enter the link into your browser.

The full manual is available for immediate download.

<https://www.ebooklibonline.com>