

BOX BLADES

BB1354

BB1360

BB1365

BB1372

BB1472

BB1484

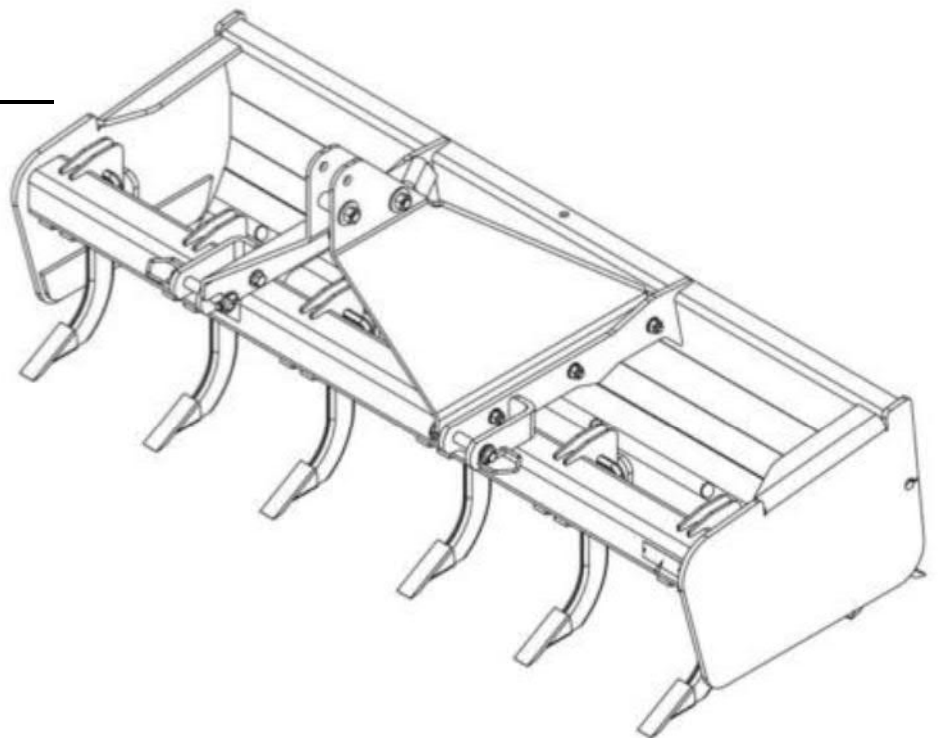



Suggest:

For more complete manuals. Please go to the home page.

<https://www.ebooklibonline.com>

If the above button click is invalid. Please download this document first, and then click the above link to download the complete manual.

Thank you so much for reading

TABLE OF CONTENTS

INTRODUCTION	2
SPECIFICATIONS	4
GENERAL INFORMATION	4
SAFETY RULES	5 - 6
SAFETY DECALS	7 - 8
OPERATION	9 - 11
OWNER SERVICE	12 - 13
ASSEMBLY	14
DEALER CHECK LISTS	15
PARTS LIST	16 - 17
BOLT TORQUE CHART	18
BOLT SIZE CHART & ABBREVIATIONS	19

<https://www.ebooklibonline.com>

Hello dear friend!

Thank you very much for reading.

Enter the link into your browser.

The full manual is available for immediate download.

<https://www.ebooklibonline.com>

<https://www.ebooklibonline.com>

Hello dear friend!

Thank you very much for reading.

Enter the link into your browser.

The full manual is available for immediate download.

<https://www.ebooklibonline.com>