

# BOX BLADES

**BB1048**

**BB1060**

**BB1065**

**BB1072**

**BB1160**

**BB1165**

**BB1172**

**BB1184**

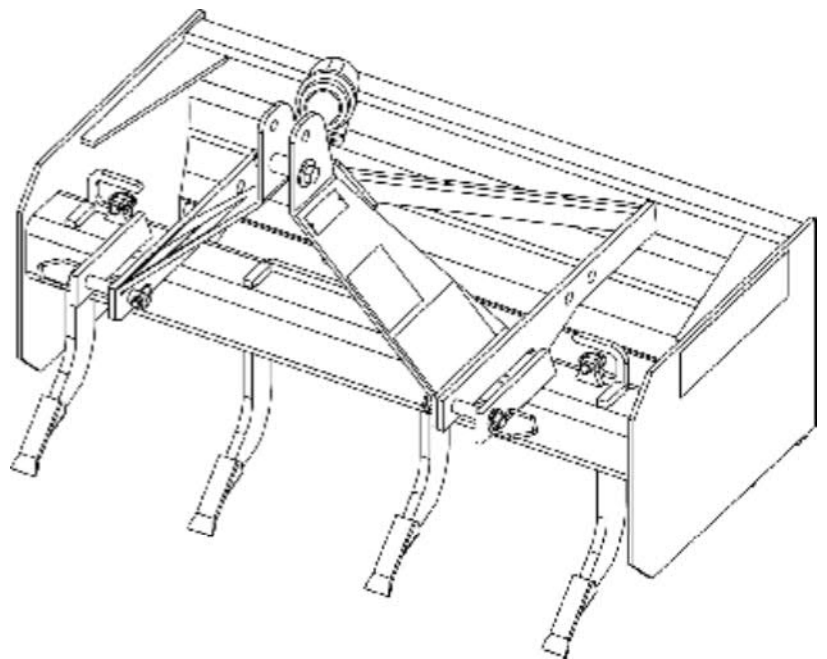

**FRONTIER**  
EQUIPMENT™



**Suggest:**

**For more complete manuals. Please go to the home page.**

**<https://www.ebooklibonline.com>**

**If the above button click is invalid. Please download this document first, and then click the above link to download the complete manual.**

**Thank you so much for reading**

# TABLE OF CONTENTS

INTRODUCTION .....	INSIDE FRONT COVER
SPECIFICATIONS .....	2
GENERAL INFORMATION .....	2
SAFETY RULES .....	3 - 4
SAFETY DECALS .....	5 - 6
DEALER CHECK LISTS .....	7
OPERATION .....	8 - 9
OWNER SERVICE .....	10 - 11
PARTS LIST .....	12
BOLT TORQUE CHART .....	14
BOLT SIZE CHART & ABBREVIATIONS .....	15
PRODUCT WARRANTY .....	16
REPLACEMENT PARTS WARRANTY .....	INSIDE BACK COVER



**This Operator's Manual should be regarded as part of the machine. Suppliers of both new and second-hand machines must make sure that this manual is provided with the machine.**

**<https://www.ebooklibonline.com>**

Hello dear friend!

Thank you very much for reading.

Enter the link into your browser.

The full manual is available for immediate download.

**<https://www.ebooklibonline.com>**

**<https://www.ebooklibonline.com>**

Hello dear friend!

Thank you very much for reading.

Enter the link into your browser.

The full manual is available for immediate download.

**<https://www.ebooklibonline.com>**