

3950 and 3970 Forage Harvesters

(Serial No. 915001-)

John Deere Ottumwa Works
OME87600 Issue H5
**(Mark old manual OME82551 I2 for
machines up to Serial No. 915001)**

LITHO IN U.S.A.
ENGLISH

Introduction

READ THIS MANUAL carefully to learn how to operate and service your machine correctly. Failure to do so could result in personal injury or equipment damage. This manual and safety signs on your machine may also be available in other languages. (See your John Deere dealer to order.)

THIS MANUAL SHOULD BE CONSIDERED a permanent part of your machine and should remain with the machine when you sell it.

MEASUREMENTS in this manual are given in both metric and customary U.S. unit equivalents. Use only correct replacement parts and fasteners. Metric and inch fasteners may require a specific metric or inch wrench.

RIGHT-HAND AND LEFT-HAND sides are determined by facing in the direction the implement will travel when going forward.

WRITE PRODUCT IDENTIFICATION NUMBERS (P.I.N.) in the Specification section. Accurately record all the numbers to help in tracing the machine should

it be stolen. Your dealer also needs these numbers when you order parts. File the identification numbers in a secure place off the machine.

WARRANTY is provided as part of John Deere's support program for customers who operate and maintain their equipment as described in this manual. The warranty is explained on the warranty certificate which you should have received from your dealer.

This warranty provides you the assurance that John Deere will back its products where defects appear within the warranty period. In some circumstances, John Deere also provides field improvements, often without charge to the customer, even if the product is out of warranty. Should the equipment be abused, or modified to change its performance beyond the original factory specifications, the warranty will become void and field improvements may be denied. Setting fuel delivery above specifications or otherwise overpowering machines will result in such action.

THE TIRE MANUFACTURER'S warranty applicable to your machine may not apply outside the U.S.

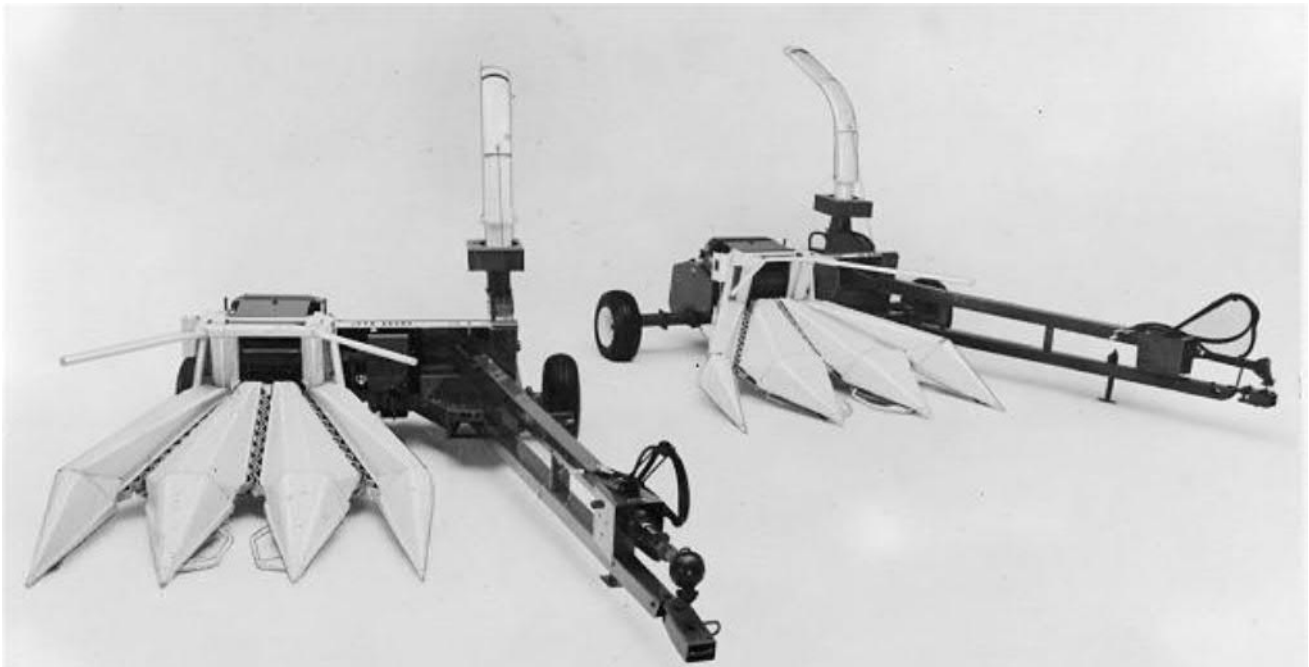

3950 and 3970 Forage Harvesters

E23769
-UN-23AUG89

EX,OM3970,IFCA -19-30AUG95

Safety

RECOGNIZE SAFETY INFORMATION

This is the safety-alert symbol. When you see this symbol on your machine or in this manual, be alert to the potential for personal injury.

Follow recommended precautions and safe operating practices.

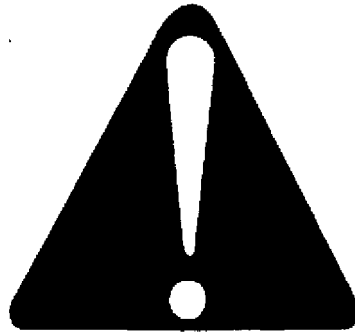

DX,ALERT -19-03MAR93

T81389 -UN-07DEC68

UNDERSTAND SIGNAL WORDS

A signal word—DANGER, WARNING, or CAUTION—is used with the safety-alert symbol. DANGER identifies the most serious hazards.

DANGER or WARNING safety signs are located near specific hazards. General precautions are listed on CAUTION safety signs. CAUTION also calls attention to safety messages in this manual.



DX,SIGNAL -19-03MAR93

TS187 -19-30SEP88

FOLLOW SAFETY INSTRUCTIONS

Carefully read all safety messages in this manual and on your machine safety signs. Keep safety signs in good condition. Replace missing or damaged safety signs. Be sure new equipment components and repair parts include the current safety signs. Replacement safety signs are available from your John Deere dealer.

Learn how to operate the machine and how to use controls properly. Do not let anyone operate without instruction.

Keep your machine in proper working condition. Unauthorized modifications to the machine may impair the function and/or safety and affect machine life.

If you do not understand any part of this manual and need assistance, contact your John Deere dealer.

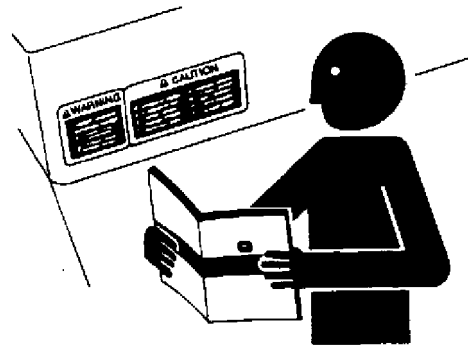

DX,READ -19-03MAR93

TS201 -UN-23AUG88

<https://www.ebooklibonline.com>

Hello dear friend!

Thank you very much for reading.

Enter the link into your browser.

The full manual is available for immediate download.

<https://www.ebooklibonline.com>



OPERATE FORAGE HARVESTER SAFELY

All machinery must be operated by responsible persons who have been properly instructed and delegated to do so.

Do not stand under discharge spout while harvester is operating.

Do not stand between harvesting unit and tongue while positioning tongue.

Harvesting unit may move suddenly or fall while detaching. Release stored energy from pickup float system before detaching harvesting unit.

Do not put hands or feet between tongue and frame opening while positioning tongue.

Always operate machine at rated PTO speed.

To avoid injury or death:

Disengage drives, shut off engine, and make sure electrical power is off before servicing or unplugging the harvesting unit or machine. The feed rolls can feed crop material faster than you can release your grip on the material.

Do not use your hands or feet to feed crop into the forage harvester, with or without a harvesting unit.

Do not stand between harvesting unit and tongue when detaching harvesting unit.

This forage harvester is intended for mobile field operation only. Never use or modify machine to be used in a stationary operation.



-UN-23AUG68

TS263

-UN-12SEP88

E32293

E03.3970C,U -19-29NOV91



KEEP RIDERS OFF MACHINE

Only allow the operator on the machine. Keep riders off.

Riders on machine are subject to injury such as being struck by foreign objects and being thrown off of the machine. Riders also obstruct the operator's view resulting in the machine being operated in an unsafe manner.

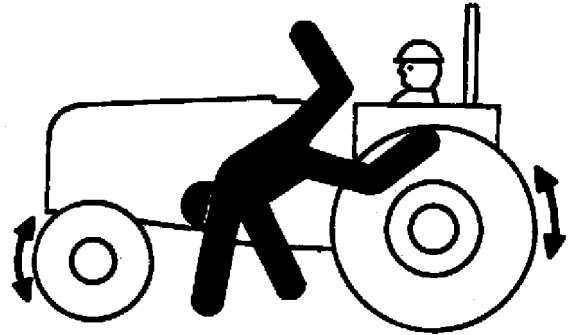

DX,RIDER -19-03MAR93

TS290
-UN-23AUG88

PREPARE FOR EMERGENCIES

Be prepared if a fire starts.

Keep a first aid kit and fire extinguisher handy.

Keep emergency numbers for doctors, ambulance service, hospital, and fire department near your telephone.

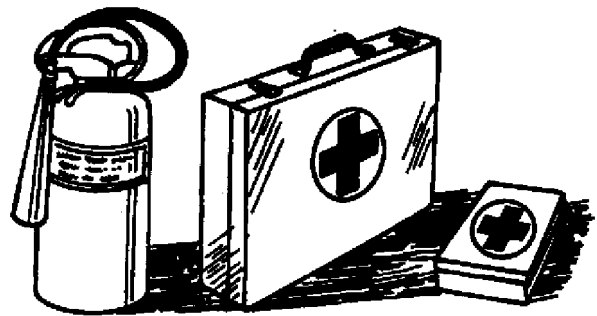

DX,FIRE2 -19-03MAR93

TS291
-UN-23AUG88

WEAR PROTECTIVE CLOTHING

Wear close fitting clothing and safety equipment appropriate to the job.

Prolonged exposure to loud noise can cause impairment or loss of hearing.

Wear a suitable hearing protective device such as earmuffs or earplugs to protect against objectionable or uncomfortable loud noises.

Operating equipment safely requires the full attention of the operator. Do not wear radio or music headphones while operating machine.

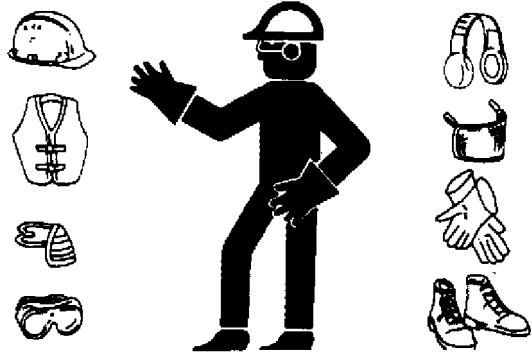

DX,WEAR -19-10SEP90

TS206
-UN-23AUG88



HANDLE CHEMICAL PRODUCTS SAFELY

Direct exposure to hazardous chemicals can cause serious injury. Potentially hazardous chemicals used with John Deere equipment include such items as lubricants, coolants, paints, and adhesives.

A Material Safety Data Sheet (MSDS) provides specific details on chemical products: physical and health hazards, safety procedures, and emergency response techniques.

Check the MSDS before you start any job using a hazardous chemical. That way you will know exactly what the risks are and how to do the job safely. Then follow procedures and recommended equipment.

(See your John Deere dealer for MSDS's on chemical products used with John Deere equipment.)



DX,MSDS,NA -19-03MAR93

TS1132 -UN-26NOV90

STAY CLEAR OF ROTATING DRIVELINES

Entanglement in rotating driveline can cause serious injury or death.

Keep tractor master shield and driveline shields in place at all times. Make sure rotating shields turn freely.

Wear close fitting clothing. Stop the engine and be sure PTO driveline is stopped before making adjustments, connections, or cleaning out PTO driven equipment.



DX,PTO -19-12SEP95

TS1644 -UN-22AUG95



USE SAFETY LIGHTS AND DEVICES

Prevent collisions between other road users, slow moving tractors with attachments or towed equipment, and self-propelled machines on public roads. Frequently check for traffic from the rear, especially in turns, and use hand signals or turn signal lights.

Use headlights, flashing warning lights, and turn signals day and night. Follow local regulations for equipment lighting and marking. Keep lighting and marking visible and in good working order. Replace or repair lighting and marking that has been damaged or lost. An implement safety lighting kit is available from your John Deere dealer.

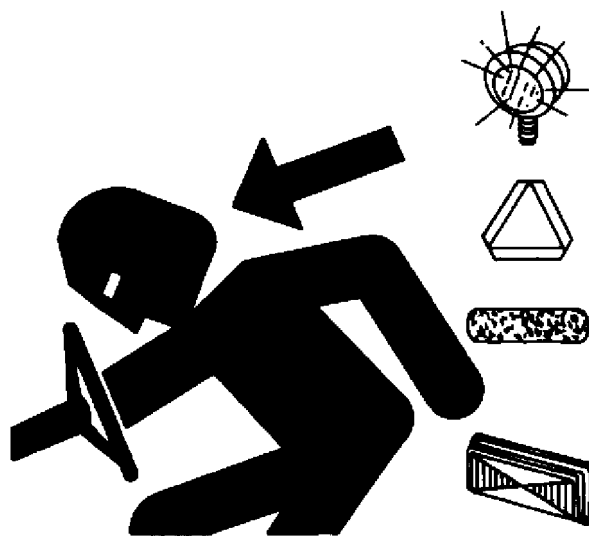

DX,FLASH -19-12SEP95

TSS951 -UN-12APR90

USE A SAFETY CHAIN

A safety chain will help control drawn equipment should it accidentally separate from the drawbar.

Using the appropriate adapter parts, attach the chain to the tractor drawbar support or other specified anchor location. Provide only enough slack in the chain to permit turning.

See your John Deere dealer for a chain with a strength rating equal to or greater than the gross weight of the towed machine. Do not use safety chain for towing.

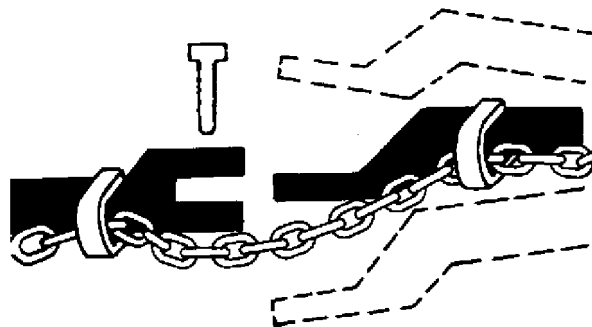

DX,CHAIN -19-03MAR93

TSS217 -UN-23AUG88



TOW LOADS SAFELY

Towed loads with or without brakes that are too heavy for the tractor or are towed too fast can cause loss of control. Use additional caution when towing loads under adverse surface conditions, when turning, and on inclines.

For tractors towing loads more than 1.5 t (3300 lb):

- If towed equipment does not have brakes, do not travel more than 32 km/h (20 mph) and do not tow loads more than 1.5 times the tractor weight. Ensure the load does not exceed 1.5 times the tractor weight by adding ballast to tractor, lightening the load, or getting a heavier towing unit.
- If towed equipment has brakes, do not travel more than 40 km/h (25 mph) and do not tow loads more than 4.5 times the tractor weight.

Consider the total weight of the equipment and its load.

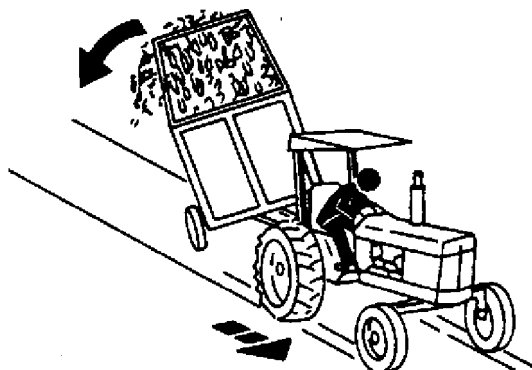

DX,TOW -19-27JUL95

TS216 -UN-23AUG88

PRACTICE SAFE MAINTENANCE

Understand service procedure before doing work. Keep area clean and dry.

Never lubricate, service, or adjust machine while it is moving. Keep hands, feet, and clothing from power-driven parts. Disengage all power and operate controls to relieve pressure. Lower equipment to the ground. Stop the engine. Remove the key. Allow machine to cool.

Securely support any machine elements that must be raised for service work.

Keep all parts in good condition and properly installed. Fix damage immediately. Replace worn or broken parts. Remove any buildup of grease, oil, or debris.

Disconnect battery ground cable (-) before making adjustments on electrical systems or welding on machine.



DX,SERV -19-03MAR93

TS216 -UN-23AUG88



REMOVE PAINT BEFORE WELDING OR HEATING

Avoid potentially toxic fumes and dust.

Hazardous fumes can be generated when paint is heated by welding, soldering, or using a torch.

Do all work outside or in a well ventilated area. Dispose of paint and solvent properly.

Remove paint before welding or heating:

- If you sand or grind paint, avoid breathing the dust. Wear an approved respirator.
- If you use solvent or paint stripper, remove stripper with soap and water before welding. Remove solvent or paint stripper containers and other flammable material from area. Allow fumes to disperse at least 15 minutes before welding or heating.

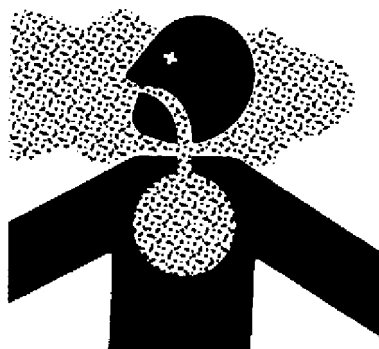

DX,PAINT -19-03MAR93

TS220 -UN-23AUG68

AVOID HEATING NEAR PRESSURIZED FLUID LINES

Flammable spray can be generated by heating near pressurized fluid lines, resulting in severe burns to yourself and bystanders. Do not heat by welding, soldering, or using a torch near pressurized fluid lines or other flammable materials. Pressurized lines can be accidentally cut when heat goes beyond the immediate flame area.



DX,TORCH -19-03MAR93

TS953 -UN-15MAY90



AVOID HIGH-PRESSURE FLUIDS

Escaping fluid under pressure can penetrate the skin causing serious injury.

Avoid the hazard by relieving pressure before disconnecting hydraulic or other lines. Tighten all connections before applying pressure.

Search for leaks with a piece of cardboard. Protect hands and body from high pressure fluids.

If an accident occurs, see a doctor immediately. Any fluid injected into the skin must be surgically removed within a few hours or gangrene may result. Doctors unfamiliar with this type of injury should reference a knowledgeable medical source. Such information is available from Deere & Company Medical Department in Moline, Illinois, U.S.A.

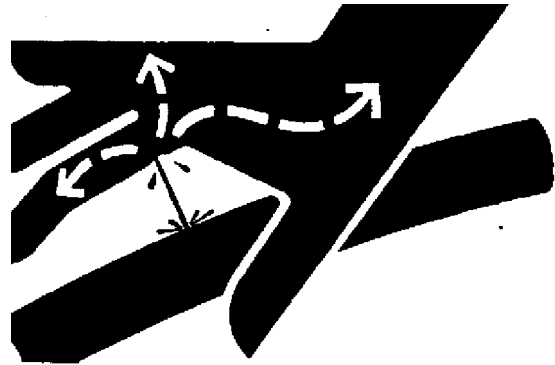

X9811 -UN-23AUG88

DX,FLUID -19-03MAR93

DISPOSE OF WASTE PROPERLY

Improperly disposing of waste can threaten the environment and ecology. Potentially harmful waste used with John Deere equipment include such items as oil, fuel, coolant, brake fluid, filters, and batteries.

Use leakproof containers when draining fluids. Do not use food or beverage containers that may mislead someone into drinking from them.

Do not pour waste onto the ground, down a drain, or into any water source.

Air conditioning refrigerants escaping into the air can damage the Earth's atmosphere. Government regulations may require a certified air conditioning service center to recover and recycle used air conditioning refrigerants.

Inquire on the proper way to recycle or dispose of waste from your local environmental or recycling center, or from your John Deere dealer.

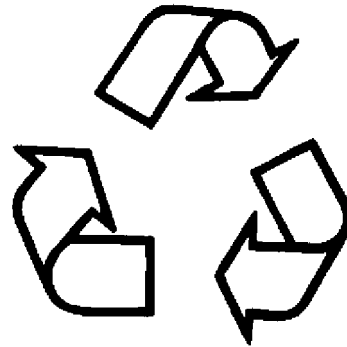

TS1133 -UN-26NOV90

DX,DRAIN -19-03MAR93

Safety Signs



E36272 -JUN-14NOV91

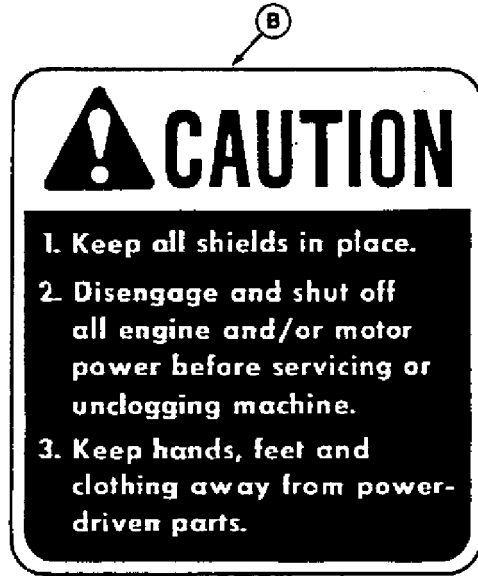

E36271 -19-12NOV91



E36270 -19-12NOV91

EX,3970Z,A -19-30OCT91

Safety Signs

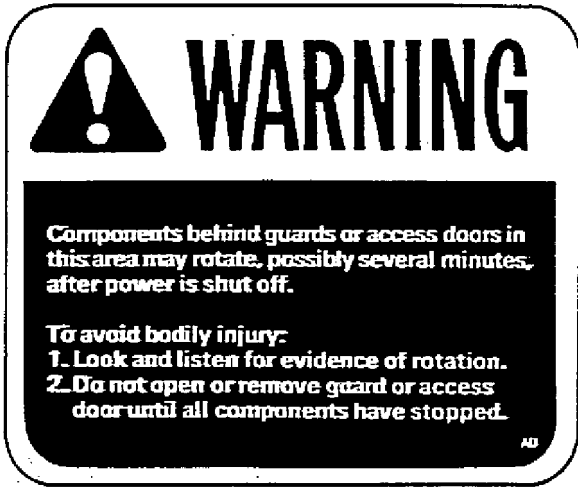

E36273 -19-12NOV91



EX.3970Z,B -19-30OCT91



E36273 -19-12NOV91



EX.3970Z,C -19-30OCT91

Safety Signs

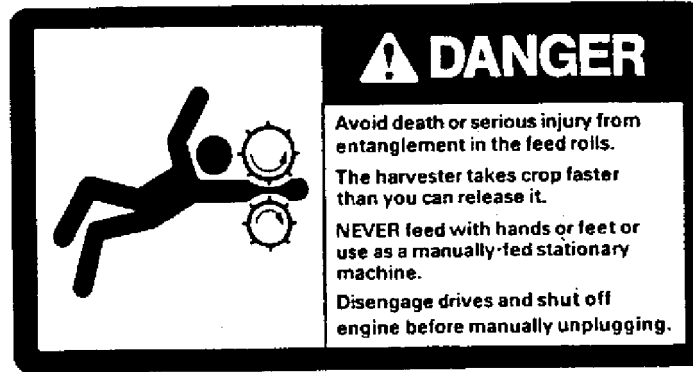

E36269 -19-12NOV91



EX,3970Z,D -19-30OCT91



E36283 -19-12NOV91



EX,3970Z,E -19-30OCT91

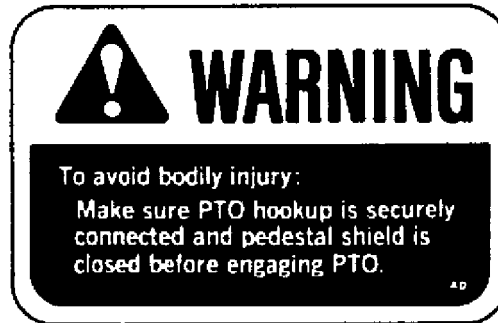

E36282 -19-12NOV91

E36282



E36281 -19-12NOV91

E36281

EX,3970Z,F -19-30OCT91

Safety Signs



E36283 -19-12NOV91

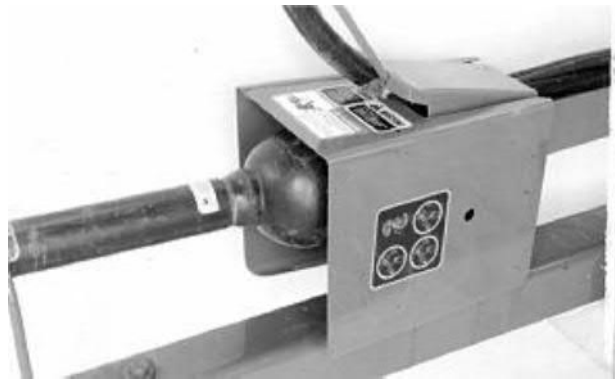

EX,3970Z,H -19-30NOV91

Safety Signs



E36624 -JUN-12NOV91

I M P O R T A N T		CAUTION
SERIOUS DAMAGE CAN OCCUR IF INSTRUCTIONS ARE NOT FOLLOWED		
<p>START-UP INSTRUCTIONS</p> <ol style="list-style-type: none"> 1. Start tractor. 2. Depress red lens of rock-er switch (switch lights and alarm will come on). 3. Shift feedrolls into reverse. 4. Engage PTO. 5. Shift feedrolls into forward. 	<p>METAL DETECTED</p> <p>Alarm and red light come on.</p> <ol style="list-style-type: none"> 1. Back up harvester. 2. Shift feedrolls into reverse. 3. Disengage PTO. 4. Shut off tractor engine. 5. Search for and remove metal. 	<p>TO AVOID SERIOUS PERSONAL INJURY:</p> <p>Never search for De-tected metal until you:</p> <ol style="list-style-type: none"> 1. Disengage PTO. 2. Shut off the engine and ignition switch. 3. Wait for all parts to stop moving.

E36625 -19-12NOV91

EX.3970Z,G -19-05NOV91

Preparing the Tractor

ADJUSTING TRACTOR DRAWBAR

The harvester can be attached to any tractor having a drawbar and PTO that conforms to ASAE-SAE standards. The tractor must have a PTO speed of 1000 rpm to match the powershaft speed of the harvester.

The tractor tire inflation pressures specified in the tractor operator's manual will apply.

1000 rpm PTO Size	A In. (mm)	B In. (mm)	C In. (mm)
1-3/8 in.	16 (406)	6-12 (152-305)	13-20 (330-508)
1-3/4 in.	20 (508)	8-12 (203-305)	13-22 (330-559)

Align drawbar hitch pin hole vertically with center-line of tractor PTO.

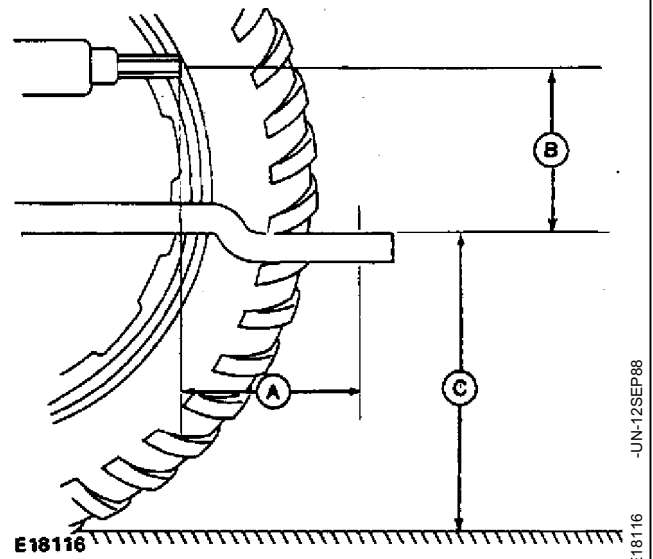

A—End of PTO Shaft to Hitch Pin Hole
B—Center of PTO Shaft to Top of Drawbar
C—Top of Drawbar to Ground

E03.3970V,A -19-20JUL92

CHECKING HITCH STRAP (SHORT TONGUE ONLY)

The hitch strap has been installed at the factory. Make sure bolts (A) are in front set of holes and tightened to 260 lb-ft (352 N-m).

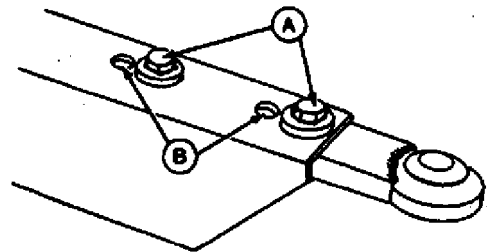

E03.3970V,B -19-29NOV91

TRACTOR ELECTRICAL HOOKUP

The control console is designed for use on 12-volt negative ground electrical systems. It is compatible with a two-terminal tractor outlet.

A two terminal convenience outlet and tractor wiring harness can be installed, if required.

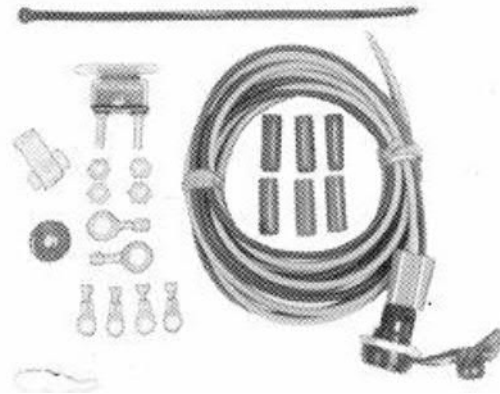

E36531 -UN-14NOV91

EX,3970V,C -19-29NOV91

A three-terminal wiring harness adapter is required to adapt the two terminal power plug to tractors equipped with a three-terminal convenience outlet. (See your John Deere dealer.)



E36532 -UN-14NOV91

EX,3970V,D -19-22OCT92

Preparing the Harvester

HARVESTING UNIT CHECKLIST

To assure the best machine performance, review the following checklist BEFORE attaching harvesting unit to harvester.

NOTE: All harvesting units used on 3950 and 3970 Forage Harvesters must be equipped with a properly adjusted slip clutch to prevent overload damage to harvesting unit. All 40 Series Ear Corn Heads have individual row unit slip clutch protection.

		Row Crops	Pickups	Ear corn Heads	Mower Bar
Wheel Spindles See Selecting Wheel Spindle Position, this section.	Down Middle	X		X	X
Axle Extensions See Selecting Axle Extensions, this section.	Installed Removed	X		X	X
Fan Speed See Changing Fan Speeds, this section.	Fast Slow	X	X	X	X
Rear Feed Roll Clearance See Adjusting Rear Feed Rolls in Operating the Harvester section.	1/16 in. 1 in.	(1.59 mm) (25 mm)	X	X	X
Tongue Stop Bolt See Using Tongue Stop Bolt, this section.	Installed Removed	X*		X*	X
Lower Feed Roll Pan See Install Lower Feed Roll Pan in Service section.	Installed Removed	X**		X	X
Recutter Screen and Supports See Install Recutter Screen and Supports in Service section.	Installed Removed	# X	## X	X	X
***Anti-Carryover Deflector See Install Anti-Carryover Deflector in Assembly section.	Installed Removed			X	
Higher Feed Roll Downstops See Adjusting Front Feed Rolls in Operating the Harvester section.	Installed Removed	X	X	X	X
Lift Cylinder and Lock-Out Plate (3970 only) See Replacing Hydraulic Cylinder in Service section.	Installed Removed			343 Only	
Pickup Float System See Operating Pickup Float System in Operating the Harvester section.	Installed		X		

* 3-Row Row-Crops and 3-Row Corn Heads Only

** Dry Grain Only

*** Use Anti-Carryover Deflector when using recutter screens.

Deflector need not be removed from machine when recutter screens are removed.

Extremely dry material may require screen.

To eliminate irregular lengths of crop it may be necessary to use recutter Screen.

E03.3970I,A -19-03DEC91



Suggest:

For more complete manuals. Please go to the home page.

<https://www.ebooklibonline.com>

If the above button click is invalid. Please download this document first, and then click the above link to download the complete manual.

Thank you so much for reading

ADJUSTING LIFT OR LOWERING RATE OF HARVESTING UNIT

It may be necessary to adjust the lift or lowering rate of the harvesting unit because of weight differences of harvesting units.

IMPORTANT: Excessively fast lift or lowering rates can cause severe damage to the machine frame and hydraulic system and should be avoided.

To adjust lowering rate, loosen jam nut (A) and turn adjusting screw (B) clockwise to slow the drop rate; counterclockwise to make drop rate faster. When desired rate of drop is achieved, tighten jam nut.

To adjust lift rate, loosen jam nut (C) and turn adjusting screw (D) clockwise to slow the lift; counterclockwise to make lift rate faster. When desired rate of lift is met, tighten jam nut securely.

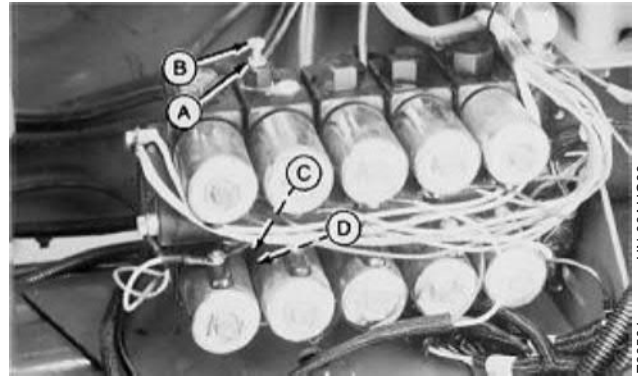

Valve with Additional Function Installed

- A—Jam Nut
- B—Adjusting Screw
- C—Jam Nut
- D—Adjusting Screw

E03.3970I,B -19-31OCT91

ADJUSTING ELECTRIC DOWNSTOP

Move downstop lever (A) forward toward position (1) to stop harvesting unit at a lower position. Move lever (A) toward position (9) to stop harvesting unit at a higher position.

NOTE: When machine is NOT in use, raise the harvesting unit and engage the lift cylinder stop to its locked position (not illustrated) or lower the harvesting unit to the ground.

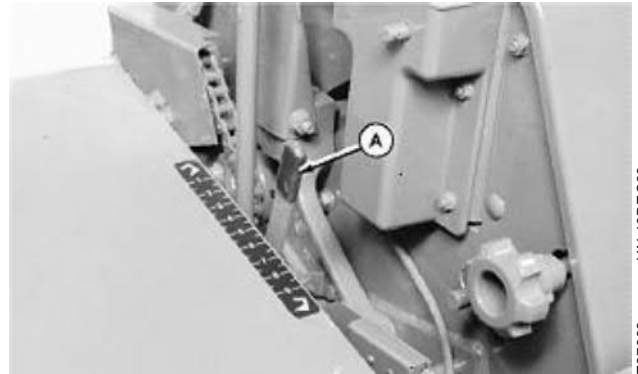

E03.3970I,CA1 -19-30AUG95

CHANGING FAN SPEEDS

The harvester is equipped with a two speed fan drive. The higher speed (1000 rpm illustrated) is used for hard to blow material such as haylage. This speed is obtained with the larger sheave on the cutterhead shaft (A).

The low speed fan (722 rpm) is used for easy to blow materials such as corn silage and is obtained with the larger sheave on the fan shaft (B).

NOTE: Use of the low speed fan may result in as much as one gear faster operation.

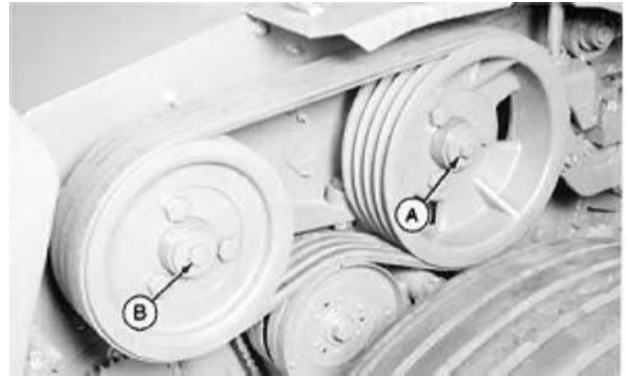

E36288 -UN-14NOV91

E03,3970I,M -19-30OCT91

1. Open auger door (A) and block fan from rotating as shown.

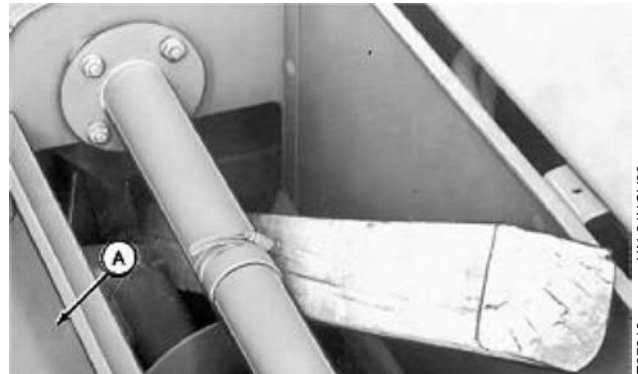

E27618 -UN-21NOV89

E03,3970I,N -19-09MAY86

<https://www.ebooklibonline.com>

Hello dear friend!

Thank you very much for reading.

Enter the link into your browser.

The full manual is available for immediate download.

<https://www.ebooklibonline.com>