

# 3940 AND 3960 FORAGE HARVESTERS



## OPERATORS MANUAL 3940 AND 3960 FORAGE HARVESTERS

OME66992 F2 English

**JOHN DEERE OTTUMWA WORKS**  
**OME66992 F2**

LITHO IN THE U.S.A.  
ENGLISH

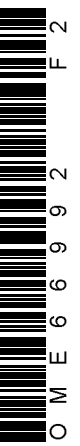

## INTRODUCTION



This safety alert symbol identifies important safety messages in this manual. When you see this symbol, be alert to the possibility of personal injury and carefully read the message that follows.

“Right-hand” and “left-hand” sides are determined by facing in the direction the harvester will travel when in use.

Record your harvester model and serial numbers on page 139.

Your warranty appears on your copy of the purchase order copy which you should have received from your dealer.

Measurements are shown with their respective Metric equivalents throughout this operator's manual. These equivalents are the SI (International System) Units of Measure.

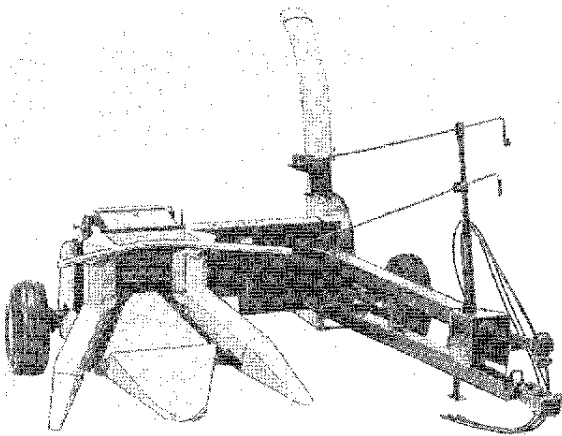

*E15979*

*John Deere 3940 Forage Harvester*

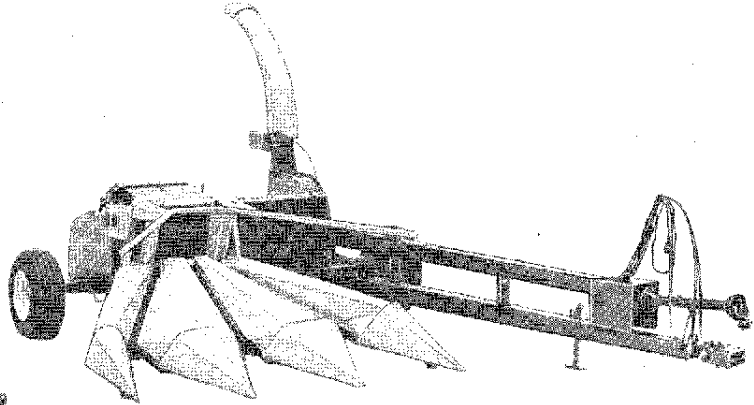

*John Deere 3960 Forage Harvester*

# JOHN DEERE 3940-3960 FORAGE HARVESTERS

## PREDELIVERY CHECK LIST

After the harvester has been completely assembled, inspect it to be sure it is in good running order before delivering it to the customer. The following check list is a reminder of points to inspect. Check off each item as it is found satisfactory or after proper adjustment is made.

- Harvester has been assembled with the pickup, row-crop, mower bar or ear corn unit as per instructions.
- Powerline shield caps are installed with flares at front and rear of tongue.
- Hydraulic hoses properly routed and clamped to avoid rubbing when tongue is pivoted.
- A liberal amount of grease was applied to spout base when assembled.
- All grease fittings have been lubricated and gear cases filled. (See lubrication section, page 50.)
- All moving parts are working freely.
- Stationary and rotating knives are properly adjusted. (Page 25.)
- Harvesting unit drive chain idler aligned and adjusted (Page 17).
- Fan blades properly adjusted.
- Feed roll drive chain idlers adjusted. (Page 84.)
- Sharpening stone is tightened against stone door. (See page 24.)
- Tires properly inflated. (Page 15.)
- Feed rolls do not touch as they rotate.
- PTO speed (540 or 1000 rpm) decals have been properly installed on tongue after checking metal identification tag on bevel gear case, see page 98.
- Proper PTO hookup and equal angle hitch is delivered with machine.
- Hitch bar located in proper set of holes for 540 or 1000 rpm, see page 7. (3960-1000 rpm only.)
- Hydraulic cylinders operate properly (after installation of pickup, row-crop, ear corn unit or mower bar unit).
- Harvester has been run for one-half hour—bearings are not heating. (After pickup, row-crop, ear corn or mower bar unit has been attached.)
- Harvester lift cylinder stop works properly.

- Make sure the harvesting unit drive slip clutch will slip.
- Feed roll flute fillers and hardware bundle are with harvester.
- Discharge spout cap control rope properly installed. (Page 104.)
- Electro hydraulic or manual controls installed and operating properly.
- Fan drive belt adjusted properly.

**IMPORTANT: Fan drive belt is overtensioned approximately 1/2-notch from that specified in "Adjusting Fan Belt Tension" on page 32. This is done at the factory to compensate for stretch and seating of new belt and should be delivered to the customer 1/2-notch overtensioned.**

### Pickup Unit:

- Chain tightener adjustment (page 36).
- Throat fillers installed correctly (page 135).
- Gauge wheel installed properly (page 134).
- Slip clutch installed and adjusted properly (page 33).
- Basic harvester wheels in mid-position (page 14).

### Row Crop Unit:

- Gathering chains adjusted (page 33).
- Slip clutch installed and adjusted properly (page 35).
- Axle extension installed on basic machine (page 139).
- Sickle assemblies adjusted properly (page 93).

### Mower Bar Unit

- V-Belt idler adjusted (page 91).
- Chain tightener adjusted (page 91).
- Slip clutch adjusted properly (page 91).

### Ear Corn Head and Mounting Parts

- Axle extensions installed on basic machine (page 14, 139).
- Recutter screens installed (page 121).
- Anti-carryover shield installed (page 123).
- Lower feed roll pan installed (page 120).
- Upper rear roll adjusted properly (page 29).
- Throat filler parts installed properly (page 128).

(Date Set Up)

(Signature)

**<https://www.ebooklibonline.com>**

Hello dear friend!

Thank you very much for reading.

Enter the link into your browser.

The full manual is available for immediate download.

**<https://www.ebooklibonline.com>**

## DELIVERY CHECK LIST

At time harvester is delivered, the following check list is a reminder of very important information which should be conveyed directly to the customer. Check off each item as it is fully explained to customer.

- Advise customer that the life expectancy of this, like any other machine, is dependent on regular lubrication as described in operator's manual.
- Advise customer of the safety precautions that must be exercised while using this harvester.
- Give the operator's manual to the customer and explain all operating adjustments and lubrication fully.
- Advise customer of two speed fan drive; how and when to use.
- Advise and show the customer the proper procedure for using the sharpening stone and importance of maintaining proper stationary knife to cutterhead knife clearance.
- Point out shear bolt safety device and proper bolt replacements.
- Explain proper ASAE standard dimensions for PTO hookups and drawbar locations for 540 or 1000 rpm. Be sure PTO hookups, equal angle hitch, and hitch bar extensions position all match metal tag on main gear case.
- Explain the operation of the manual or electro hydraulic controls.

\_\_\_\_\_  
(Date Delivered)

## OWNER REGISTER

Name .....

R. R. No. ....

City ..... State..... Zip.....

Serial Nos.: Basic Unit .....

Pickup Unit .....

Row-Crop Unit .....

Mower Bar Unit .....

Ear Corn Units .....

Operator's Manual No. OM-E66992 .....

Date Sold.....

- Explain that when the forage harvester or harvester and wagon are transported on a road or highway at night or during the day, accessory lights and devices should be used for adequate warning to operators of other vehicles. In this regard, tell customers to check local governmental regulations.
- Advise customer to raise axle on basic unit when using a row-crop unit in ridged or hilled row-crops.
- Advise the customer of the optional harvesting units and attachments that are available for special crop and operating conditions.
- Be sure feed roll flute fillers and bag of hardware are delivered to customer and that customer has been advised of circumstances when the fillers should be used. (See pages 16, 119.)

\_\_\_\_\_  
(Signature)

## AFTER-SALE CHECK LIST

It is suggested that the following items be checked sometime during the first season's operation of the forage harvester.

- Go over entire harvester for loose or missing bolts.
- Inspect the cutterhead knives and stationary knife to be sure they are sharp and properly adjusted.
- Check for proper knife clearance and register on row-crop unit.
- All chains are properly tightened on harvester and harvesting units.
- If the feed roll flute filler bundle has been installed determine if excessive shearbolt failures or wrappage of upper front feed rolls has occurred.
- See if proper fan speed is being used for crop being harvested.
- All safety shields are in place.
- Check for broken or damaged parts.
- If possible, run the harvester to see if it is functioning properly.
- Review the entire operator's manual with the customer and stress the importance of proper and regular lubrication and safety precautions.

\_\_\_\_\_  
(Date Checked)

\_\_\_\_\_  
(Signature)



# Contents

---

	Page
Safety . . . . .	2
Preparing the Tractor . . . . .	6
Preparing the Harvester . . . . .	9
Attaching and Detaching . . . . .	16
Transporting . . . . .	18
Operating the Harvester . . . . .	20
Harvesting Units and Attachments . . . . .	42
Lubrication . . . . .	50
Trouble Shooting . . . . .	57
Service . . . . .	69
Storage . . . . .	94
Assembly . . . . .	96
Specifications . . . . .	137
Index . . . . .	140



# Safety

Before servicing, adjusting or unplugging the harvester, always:

1. Disengage all power,
2. Shut off engine,
3. **THEN WAIT** until all moving parts have stopped rotating.

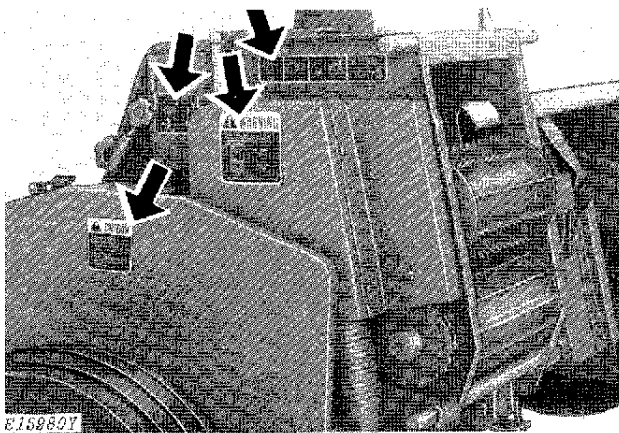

## OPERATE SAFELY

Read this operators manual thoroughly and obey ALL safety and instruction signs.

Become familiar with all controls.

Keep all safety shields in place when operating harvester.

Wear relatively tight and belted clothing to reduce the possibility of being caught on some part of the machine.

Do not allow anyone to ride on the harvester when it is in motion.



Prolonged exposure to loud noise can cause impairment or loss of hearing.

Hearing protective devices (such as ear muffs or plugs) can effectively protect against loud noise.

Never stand under discharge spout while harvester is operating.

If machine is equipped with hydraulic tongue positioner, use pin as a mechanical lock to hold tongue in transport position when transporting machine on road.

Never operate 540 rpm harvester with 1000 rpm tractor.

Stop the engine and be sure the PTO has stopped before:

- Connecting or disconnecting a PTO shaft
- Making any adjustment to PTO drive train or hitch
- Cleaning out PTO driven equipment.

PTO master shield should be in place at all times except when connecting a PTO drive line or for special applications as directed in the operator's manual.

The PTO shaft guard should be in place when the PTO is not being used.

Secure recommended safety chain to harvester as shown.

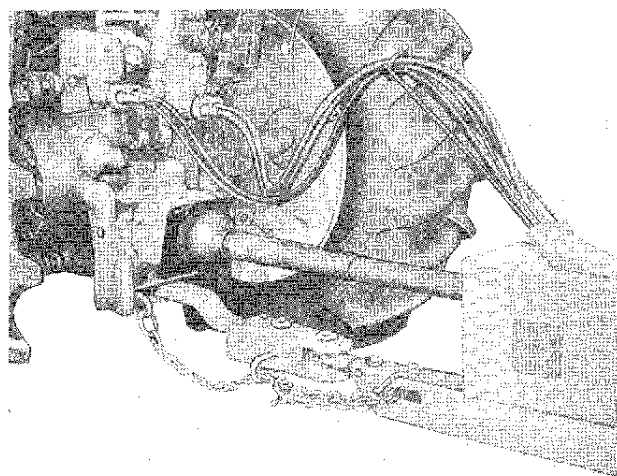

E91227

### Practice Safe Maintenance

Always stand behind machine when adjusting stationary knife.

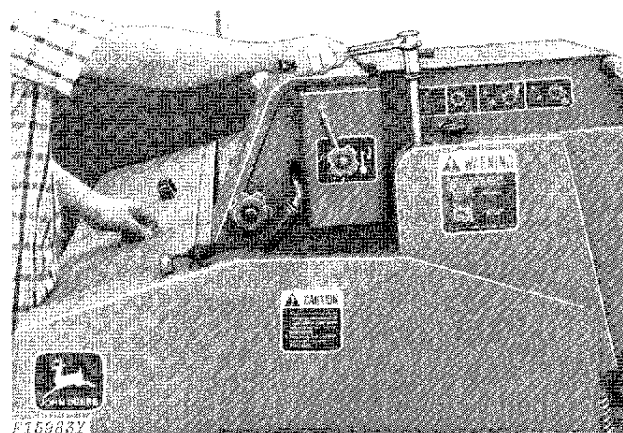

E159832

## 4 Safety

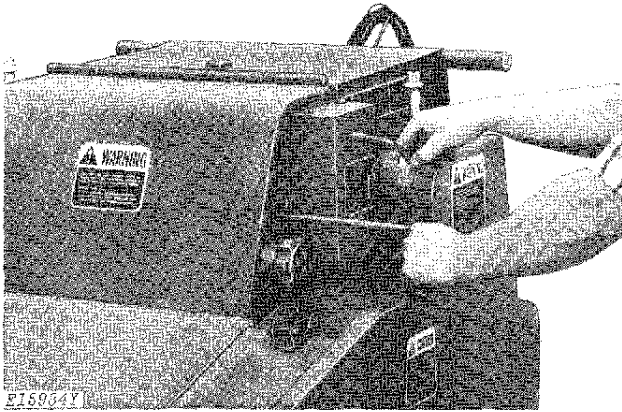

E15964Y

Always shut and latch cutterhead door when sharpening knives.

Use a wood block in the cutterhead to prevent cutterhead from turning when adjusting knives.

The auger, fan and cutterhead may continue to rotate for a few seconds after power is shut off. To avoid bodily injury, do not open or remove any doors or shields until these rotating parts have stopped completely. Keep the doors and shields latched tightly when sharpening knives.

Replace any guards and shields removed for servicing.

When machine is unattended or not in use ALWAYS lower the harvesting unit to the ground or engage lift cylinder stop.

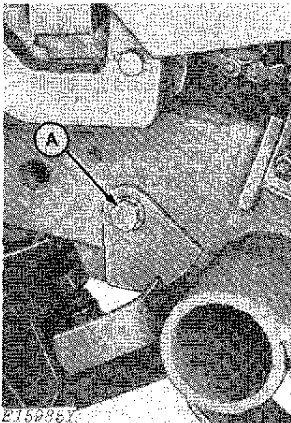

E15985Y

**A—Locked**

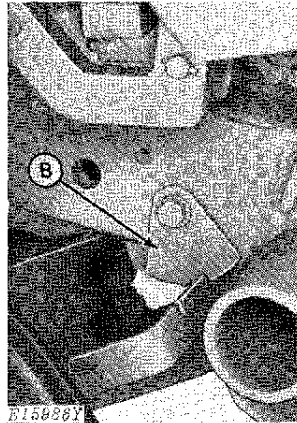

F15986Y

**B—Unlocked**

ALWAYS engage the lift cylinder stop to the locked (A) position when working on or under the harvester with the harvesting unit in the raised position.

Always return stop to the unlocked (B) position before operating. Raise harvesting unit to extreme upper position before moving handle to unlocked (B) position.

Escaping fluid under pressure can have sufficient force to penetrate the skin, causing serious personal injury. Before disconnecting lines, be sure to relieve all pressure. Before applying pressure to the system, be sure all connections are tight and that lines, pipes and hoses are not damaged.

Fluid escaping from a very small hole can be almost invisible. Use a piece of cardboard or wood, rather than hands, to search for suspected leaks.

If injured by escaping fluid, see a doctor at once. Serious infection or reaction can develop if proper medical treatment is not administered immediately.

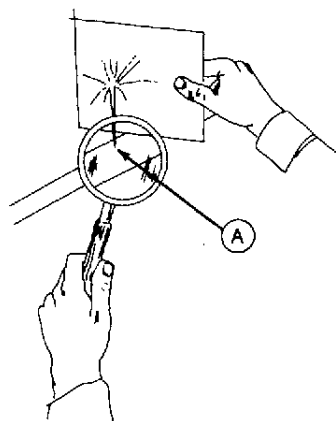

H75987

E19887

A—Pin Hole Leak

To avoid entanglement, do not feed crop material into machine by hand or attempt to manually unplug machine while it is running. The feed rolls can feed crop material in faster than you can release your grip on the material.

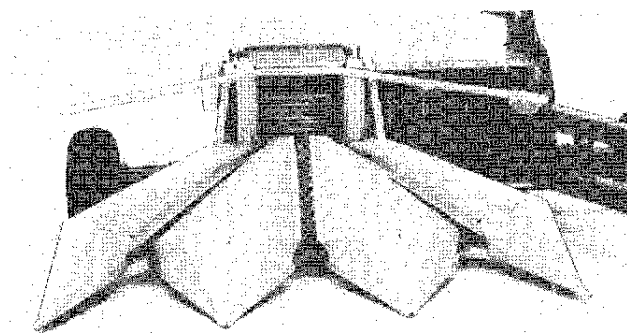

E21214



**Suggest:**

**For more complete manuals. Please go to the home page.**

**<https://www.ebooklibonline.com>**

**If the above button click is invalid. Please download this document first, and then click the above link to download the complete manual.**

**Thank you so much for reading**



# Preparing The Tractor

## ADJUSTING TRACTOR DRAWBAR

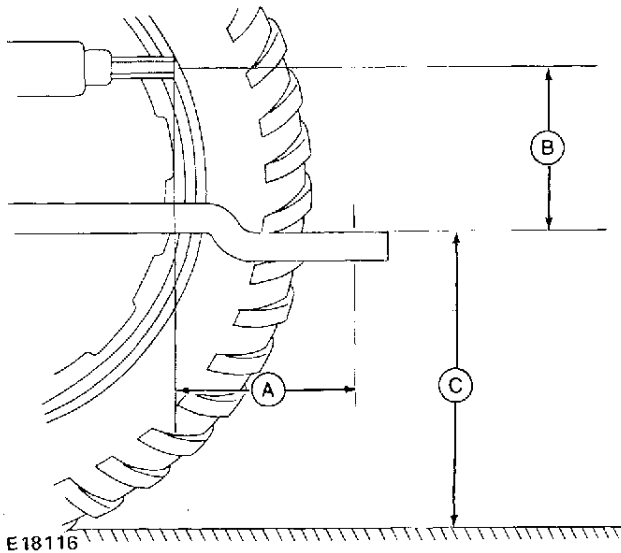

The harvester can be attached to any tractor having a drawbar and power take-off that conforms to ASAE-SAE standards. The tractor must have a power take-off speed (540 or 1000 rpm) to match the powershaft speed of the harvester.

**IMPORTANT: Do not operate harvester at 540 rpm when using a tractor with 80 horsepower (60 kW) or greater. Severe damage to the tractor or harvester may result.**

The tractor tire inflation pressures specified in the tractor operator's manual will apply.

Adjust tractor drawbar so it measures 14 inches (355 mm) (for 540 rpm PTO, 16 inches (406 mm) (1000 rpm, 1-3/8-inch PTO) or 20 inches (508 mm) (1000 rpm, 1-3/4-inch PTO) from end of power take-off shaft to hitch pin hole in drawbar (A), and 6 to 12 inches (152 to 305 mm) from center of the PTO shaft to the top of drawbar (B). The top of the rear end of drawbar should be 13 to 17 inches (330 to 432 mm) from the ground (C). The drawbar hitch pin hole must be aligned vertically with the center-line of the tractor power takeoff.

**A—End of PTO Shaft to Hitch Pin Hole**  
**B—Center of PTO Shaft to Top of Drawbar**  
**C—Top of Drawbar to Ground**

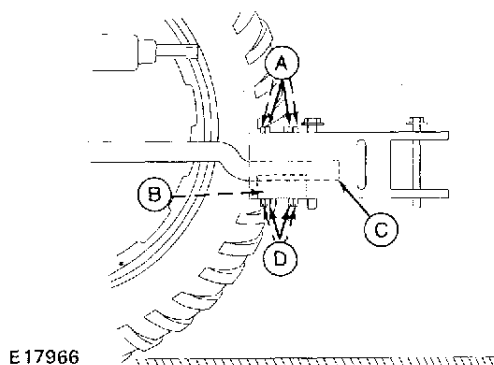

## Attaching Hitch to Drawbar

Turn four 5/8-inch bolts (A) clockwise, evenly to raise drawbar wedge (B) up against drawbar (C) snugly (loose enough to allow removal without readjustment). Then tighten lock nuts (D) securely.

Use 10-inch (254 mm) equal angle hitch with 3940 (540 and 1000 rpm) 1-3/8-inch PTO and 3960 (1000 rpm) 1-3/8-inch PTO. (Maximum drawbar size - 2-1/4 inches (57 mm) thick x 3-1/2 inches (89 mm) wide).

Use 5-1/2-inch (140 mm) equal angle hitch with 3960 (1000 rpm) 1-3/4-inch PTO. Maximum drawbar size - 2-1/4 inches (57 mm) thick x 4 inches (102 mm) wide.

**A—5/8-Inch Bolts**  
**B—Drawbar Wedge**  
**C—Drawbar**  
**D—Lock Nuts**

### Preparing Hitch Strap

Install hitch strap in front (E) set of holes for 1000 rpm machines and rear (F) set of holes for 540 rpm machines. Torque bolts to 260 ft-lbs (35 N-m).

**CAUTION:** Never operate 540 rpm harvester with 1000 rpm tractor.

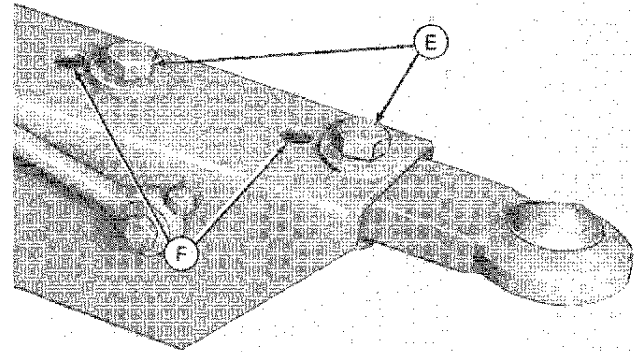

E—1000 rpm  
F—540 rpm

E21223

### PTO Hook Up

#### Attaching PTO Powr-Gard™ Hookup

**CAUTION:** Follow safe PTO hookup procedure outlined below.

1. Shut off tractor engine.
2. Move collar (B) back against stop on yoke.
3. Push button (C) and turn collar (B) until button locks in position.
4. Turn collar (B) or tractor PTO (A) to align splines.
5. Push bell (D) forward firmly until button snaps out.
6. Pull rearward on bell (D) to be sure powershaft is latched. Do NOT pull on collar as this will release latch.
7. Replace any tractor PTO shielding which was removed to attach PTO Powr-Gard Hookup.

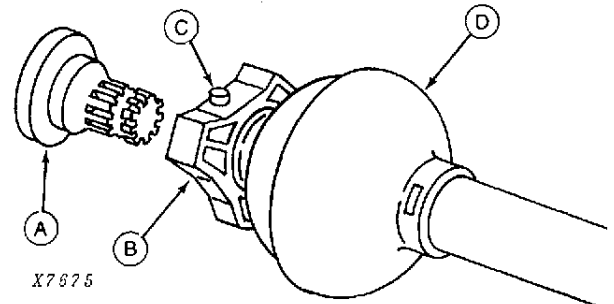

X7675

A—Tractor PTO  
B—Collar  
C—Button  
D—Bell

#### Detaching PTO Powr-Gard Hookup

**CAUTION:** Follow safe PTO detaching procedure outlined below.

1. Shut off tractor engine.
2. Support bell (D) with one hand.
3. Put collar (B) back with other hand. Button (C) need NOT be held down.
4. Replace any tractor PTO shielding which was removed to detach PTO Powr-Gard Hookup.

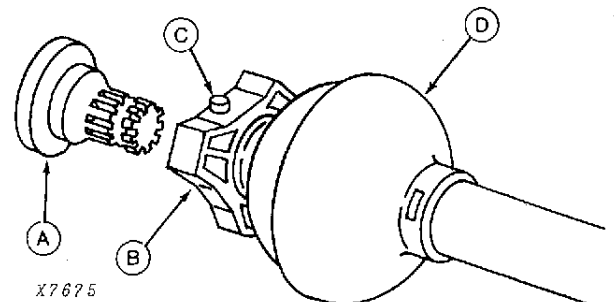

X7675

A—Tractor PTO  
B—Collar  
C—Button  
D—Bell

**<https://www.ebooklibonline.com>**

Hello dear friend!

Thank you very much for reading.

Enter the link into your browser.

The full manual is available for immediate download.

**<https://www.ebooklibonline.com>**