

890 Auger Platform With Hay Conditioner

**John Deere Ottumwa Works
OME93357 K7**

LITHO IN U.S.A.
ENGLISH

Contents

	Page		Page
Safety	05-1	Alternative and Synthetic Lubricants	20-3
Detaching and Attaching the Platform		Periodic Maintenance Label— Conditioner and Conditioner Drive Lines	20-4
Detaching the Platform	10-1	Periodic Maintenance Label—Left-Hand Side of Platform	20-5
Attaching the Platform	10-7	Periodic Maintenance Label— Right-Hand Side of Platform	20-6
Balancing The Platform	10-10	5-Hours	20-7
Operating the Auger Platform		10-Hours	20-8
Prestating Checks	15-1	50-Hours	20-10
Checking Knife Drive Belt Tension	15-2	Troubleshooting	
Breaking In The Auger Platform	15-2	Cutting	25-1
Determining Ground Speed	15-3	Feeding—Reel and Auger	25-8
Knockdown Bar	15-4	Feeding—Conditioner	25-11
Cutterbar Knife Storage	15-5	Windrow Forming	25-13
Cutterbar	15-6	Miscellaneous	25-15
Knife Overlap	15-9	Service	
Knife Hold-Downs	15-9	Practice Safe Service Procedures	30-1
Platform Guard Angle	15-10	Care of Chains	30-1
Gauge Shoes	15-10	Care of V-Belts	30-2
Reel	15-11	Installing O-Ring Connector Link	30-2
Reel Speeds	15-11	Tightening Bearing Locking Collars	30-3
Auger	15-12	Raising Reel Tooth Bar	30-4
Conditioner	15-13	Changing Reel Speed	30-5
Platform Float	15-13	Adjusting Reel Drive Belt	30-7
Windrow Formation	15-14	Adjusting Reel Chain	30-8
Dirt or Mud Buildup	15-14	Adjusting Reel Height	30-10
Cutting Alfalfa	15-15	Adjusting Reel Cam	30-14
Cutting Grass	15-16	Adjusting Conditioner Roll Spacing	30-15
Cutting Tall Crop	15-17	Adjusting Conditioner Roll Pressure	30-17
Adjusting Swath Flap	15-17	Adjusting Conditioner Roll Timing	30-18
Adjusting Platform Guard Angle	15-18	Adjusting Knife Drive Belt (Both Sides)	30-19
Adjusting Cutting Height	15-19	Adjusting Knife Drive Belt Alignment (Both Sides)	30-19
Adjusting Gauge Shoes	15-20	Adjusting Upper and Lower Strippers to Augers	30-20
Adjusting Knockdown Bar	15-21	Adjusting Center Strippers to Lower Auger	30-21
Removing Lower Auger End Clean-Out Panels	15-22	Adjusting Cam Follower to Reel Cam	30-22
Removing Lower Auger Center Deck Sheets ..	15-23	Replacing Reel Drive Belt	30-23
Lubrication and Maintenance			
Observe Lubrication Symbols	20-1		
Perform Lubrication and Maintenance	20-1		
Grease	20-2		
Gear Oil	20-2		

Continued on next page

All information, illustrations and specifications in this manual are based on the latest information available at the time of publication. The right is reserved to make changes at any time without notice.

COPYRIGHT © 1997
DEERE & COMPANY
Moline, Illinois
All rights reserved
A John Deere ILLUSTRATION® Manual

Contents

	Page
Replacing Knife Drive Belt (Both Sides)	30-25
Replacing Reel Cam Followers	30-26
Removing Tooth Bar	30-29
Replacing Reel Tooth Bar Bearings	30-30
Replacing Reel Teeth	30-32
Timing Knives	30-37
Knife Overlap	30-38
Removing Knives	30-39
Installing Knives	30-40
Cutterbar Knife Sections	30-41
Replacing Bolt-On Knife Sections	30-41
Replacing Center Knife Sections	30-42
Adjusting Regular Knife Hold-Downs	30-43
Adjusting Non-Clog Knife Hold-Downs	30-44
Installing Regular Guards	30-46
Installing Non-Clog Guards	30-54
 Attachments	
Cutterbar Knife Sections	35-1
Guage Shoe Wear Plates	35-1
Reel Drive Sprockets	35-1
Tall Crop Dividers	35-2
 Storage	
Beginning of Season	40-1
End of Season	40-2
 Specifications	
Unified Inch Bolt and Cap Screw Torque Values	45-1
Metric Bolt and Cap Screw Torque Values	45-3
Specifications	45-4
 Identification Numbers	
Serial Number Plate	50-1
Record Serial Numbers	50-1
 Crime Prevention Tips	
Help Prevent Crime	55-1
Record Identification Numbers	55-1
Keep Proof of Ownership	55-1
Park Indoors Out of Sight	55-2
When Parking Outdoors	55-2
Reduce Vandalism	55-3
Report Thefts Immediately	55-3
 John Deere Service Keeps You On The Job	
John Deere Is At Your Service When You Need It	IBC-1

<https://www.ebooklibonline.com>

Hello dear friend!

Thank you very much for reading.

Enter the link into your browser.

The full manual is available for immediate download.

<https://www.ebooklibonline.com>

Safety

RECOGNIZE SAFETY INFORMATION

This is the safety-alert symbol. When you see this symbol on your machine or in this manual, be alert to the potential for personal injury.

Follow recommended precautions and safe operating practices.



DX.ALERT -19-03MAR93-1/1

T81389 -JUN-07DEC88

UNDERSTAND SIGNAL WORDS

A signal word—DANGER, WARNING, or CAUTION—is used with the safety-alert symbol. DANGER identifies the most serious hazards.

DANGER or WARNING safety signs are located near specific hazards. General precautions are listed on CAUTION safety signs. CAUTION also calls attention to safety messages in this manual.



▲ WARNING

▲ CAUTION

DX.SIGNAL -19-03MAR93-1/1

TS187 -19-30SEP88

FOLLOW SAFETY INSTRUCTIONS

Carefully read all safety messages in this manual and on your machine safety signs. Keep safety signs in good condition. Replace missing or damaged safety signs. Be sure new equipment components and repair parts include the current safety signs. Replacement safety signs are available from your John Deere dealer.

Learn how to operate the machine and how to use controls properly. Do not let anyone operate without instruction.

Keep your machine in proper working condition. Unauthorized modifications to the machine may impair the function and/or safety and affect machine life.

If you do not understand any part of this manual and need assistance, contact your John Deere dealer.

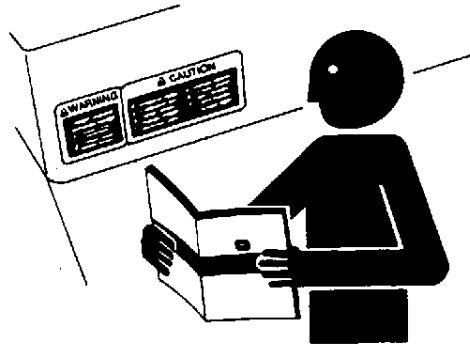

TS201 -UN-23AUG88

DX,READ -19-03MAR93-1/1

BEFORE OPERATING

Become familiar with operator's manual, machine decals, and Safety section of this manual.

Remove foreign objects from machine.

Become familiar with all controls effecting machine functions.

Make sure everyone is clear of the machine. Never allow riders on machine or near machine while it is running.

Be sure shields and guards are in place and in good condition before starting. Some driveline and hookup shields are designed to stop rotating upon contact while the shaft continues to rotate.

Check rotating shields to ensure they are free to turn. Make necessary repairs if these shields will not turn.

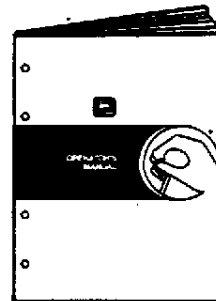

E23482 -UN-08MAY89

OME,890AP,OPER -19-11FEB97-1/1

WEAR PROTECTIVE CLOTHING

Wear close fitting clothing and safety equipment appropriate to the job.

Prolonged exposure to loud noise can cause impairment or loss of hearing.

Wear a suitable hearing protective device such as earmuffs or earplugs to protect against objectionable or uncomfortable loud noises.

Operating equipment safely requires the full attention of the operator. Do not wear radio or music headphones while operating machine.

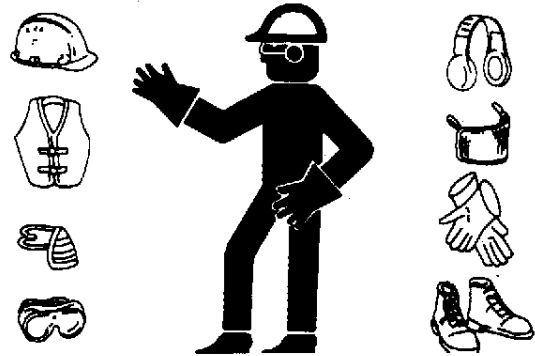

TS206 -JUN-23AUG88

DX.WEAR -19-10SEP90-1/1

HANDLE CHEMICAL PRODUCTS SAFELY

Direct exposure to chemical products can cause severe skin irritation and injury. Hazardous fumes can be generated when handling the chemicals.

Wear close fitting clothing and a face mask when handling chemicals. Dispose of chemical waste and packaging material properly.

A Material Safety Data Sheet provides specific details on chemical products and physical dangers, safety procedures, and emergency response techniques. User awareness and training is required under U.S. workplace and environmental laws. See your John Deere dealer for information on chemical products used with John Deere equipment.

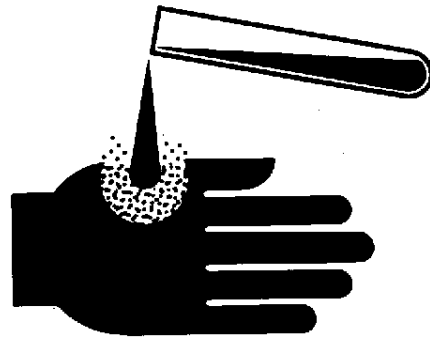

TS272 -JUN-23AUG88

DX.MSDS -19-28SEP90-1/1

STAY CLEAR OF ROTATING DRIVELINES

Entanglement in rotating driveline can cause serious injury or death.

Keep tractor master shield and driveline shields in place at all times. Make sure rotating shields turn freely.

Wear close fitting clothing. Stop the engine and be sure PTO driveline is stopped before making adjustments, connections, or cleaning out PTO driven equipment.



TS1644 -JUN-22AUG95

DX.PTO -19-12SEP95-1/1

USE SAFETY LIGHTS AND DEVICES

Prevent collisions between other road users, slow moving tractors with attachments or towed equipment, and self-propelled machines on public roads. Frequently check for traffic from the rear, especially in turns, and use hand signals or turn signal lights.

Use headlights, flashing warning lights, and turn signals day and night. Follow local regulations for equipment lighting and marking. Keep lighting and marking visible and in good working order. Replace or repair lighting and marking that has been damaged or lost. An implement safety lighting kit is available from your John Deere dealer.

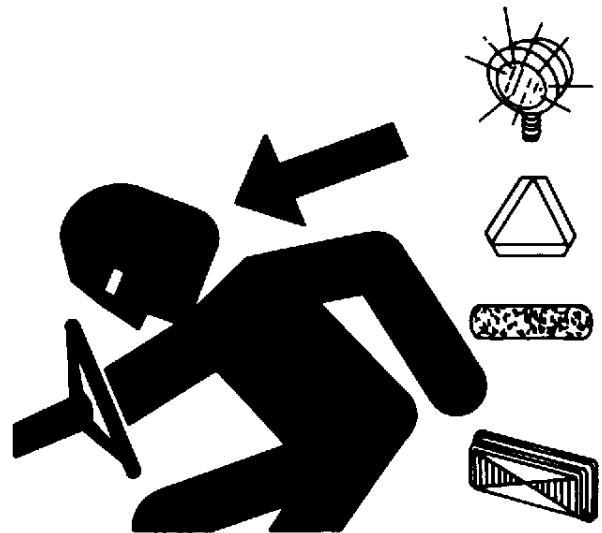

TS951 -JUN-12APR90

DX.FLASH -19-12SEP95-1/1

USE PROPER TOOLS

Use tools appropriate to the work. Makeshift tools and procedures can create safety hazards.

Use power tools only to loosen threaded parts and fasteners.

For loosening and tightening hardware, use the correct size tools. **DO NOT** use U.S. measurement tools on metric fasteners. Avoid bodily injury caused by slipping wrenches.

Use only service parts meeting John Deere specifications.



TS779 -JUN-08NOV89

DX,REPAIR -19-04JUN90-1/1

PRACTICE SAFE MAINTENANCE

Understand service procedure before doing work. Keep area clean and dry.

Never lubricate, service, or adjust machine while it is moving. Keep hands, feet, and clothing from power-driven parts. Disengage all power and operate controls to relieve pressure. Lower equipment to the ground. Stop the engine. Remove the key. Allow machine to cool.

Securely support any machine elements that must be raised for service work.

Keep all parts in good condition and properly installed. Fix damage immediately. Replace worn or broken parts. Remove any buildup of grease, oil, or debris.

Disconnect battery ground cable (-) before making adjustments on electrical systems or welding on machine.



TS218 -JUN-23AUG88

DX,SERV -19-03MAR93-1/1

AVOID HEATING NEAR PRESSURIZED FLUID LINES

Flammable spray can be generated by heating near pressurized fluid lines, resulting in severe burns to yourself and bystanders. Do not heat by welding, soldering, or using a torch near pressurized fluid lines or other flammable materials. Pressurized lines can be accidentally cut when heat goes beyond the immediate flame area.



TS953 -UN-15MAY90

DX,TORCH -19-03MAR93-1/1

AVOID HIGH-PRESSURE FLUIDS

Escaping fluid under pressure can penetrate the skin causing serious injury.

Avoid the hazard by relieving pressure before disconnecting hydraulic or other lines. Tighten all connections before applying pressure.

Search for leaks with a piece of cardboard. Protect hands and body from high pressure fluids.

If an accident occurs, see a doctor immediately. Any fluid injected into the skin must be surgically removed within a few hours or gangrene may result. Doctors unfamiliar with this type of injury should reference a knowledgeable medical source. Such information is available from Deere & Company Medical Department in Moline, Illinois, U.S.A.

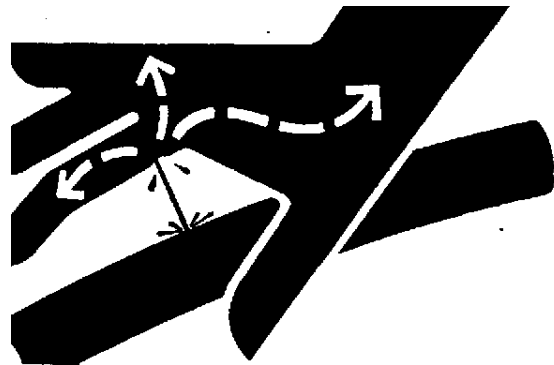

X9811 -UN-23AUG88

DX,FLUID -19-03MAR93-1/1

STORE ATTACHMENTS SAFELY

Stored attachments such as dual wheels, cage wheels, and loaders can fall and cause serious injury or death.

Securely store attachments and implements to prevent falling. Keep playing children and bystanders away from storage area.

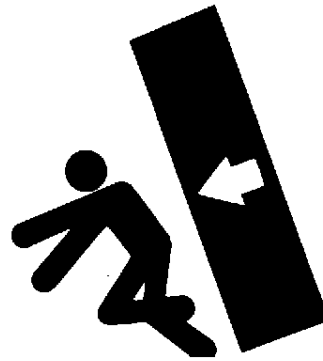

DX.STORE -19-03MAR93-1/1

TS219 -JUN-23AUG88

DISPOSE OF WASTE PROPERLY

Improperly disposing of waste can threaten the environment and ecology. Potentially harmful waste used with John Deere equipment include such items as oil, fuel, coolant, brake fluid, filters, and batteries.

Use leakproof containers when draining fluids. Do not use food or beverage containers that may mislead someone into drinking from them.

Do not pour waste onto the ground, down a drain, or into any water source.

Air conditioning refrigerants escaping into the air can damage the Earth's atmosphere. Government regulations may require a certified air conditioning service center to recover and recycle used air conditioning refrigerants.

Inquire on the proper way to recycle or dispose of waste from your local environmental or recycling center, or from your John Deere dealer.

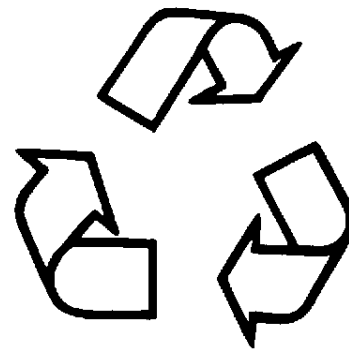

DX.DRAIN -19-03MAR93-1/2

TS1133 -JUN-26NOV90

Safety



E43000 -19-15OCT97

DX.DRAIN -19-03MAR93-2/2

Detaching and Attaching the Platform

DETACHING THE PLATFORM

CAUTION: To prevent bodily injury it is necessary to read the John Deere 4890 Self-Propelled Windrower operator's manual and familiarize yourself with the operation of the John Deere 4890 Self-Propelled Windrower.

IMPORTANT: To prevent machine damage and insure a properly operating platform, it is necessary to read the John Deere 4890 Self-Propelled Windrower operator's manual and familiarize yourself with the operation of the John Deere 4890 Self-Propelled Windrower.

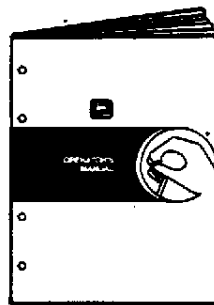

E23482 -JUN-08MAY89

OME,890AP,15,A -19-11FEB97-1/12

CAUTION: To prevent bodily injury, do not work under or around a raised platform without engaging the platform lift lockout lever (A).

1. Start windrower.
2. Raise platform and engage platform lift lockout lever (A). Shut off windrower.

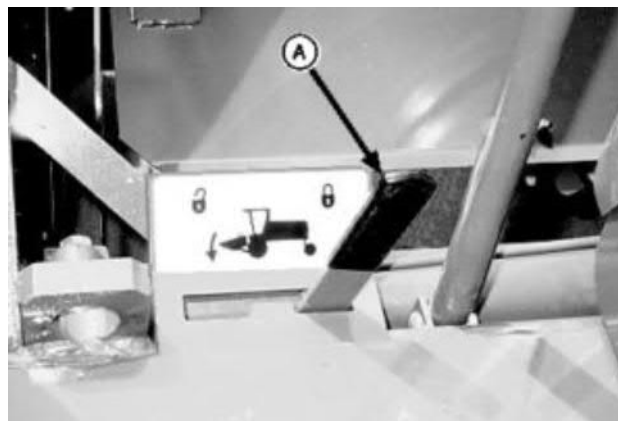

E40698 -JUN-06AUG96

OME,890AP,15,A -19-11FEB97-2/12

3. Raise all gauge shoes (B) to lowest cutting height and remove cotter pins (C) from right-hand and left-hand lift arm retaining pins.
4. Start windrower, disengage platform lift lockout lever, lower platform to the ground and shut off windrower.

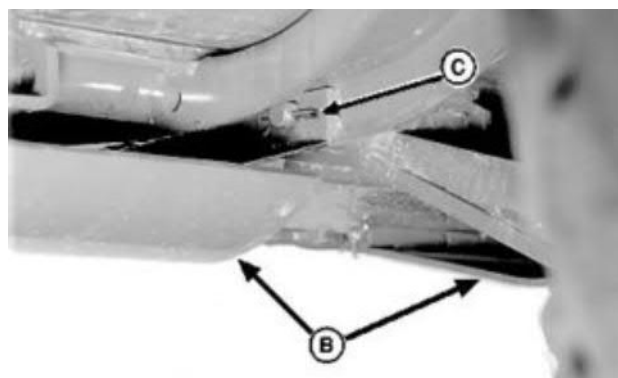

E40699 -JUN-02FEB97

OME,890AP,15,A -19-11FEB97-3/12

Detaching and Attaching the Platform

5. Disconnect electrical harness (A) from windrower.
6. Turn knob (B) on windrower accumulator / float pressure valve counter-clockwise to release pressure in the accumulator.

NOTE: Components removed should be placed in the storage box (C).

7. Components needed may be found in the storage box (C).



E40700 -JUN-06AUG96

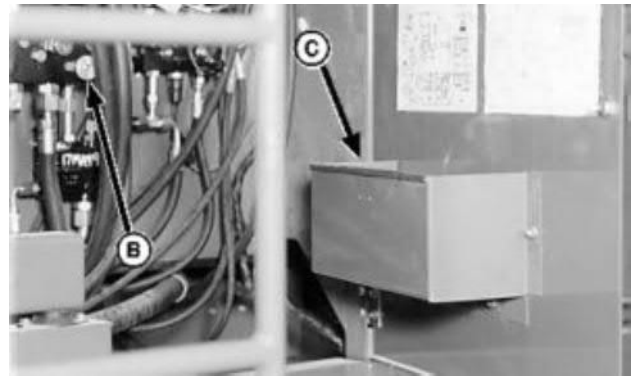

E40701 -JUN-06AUG96

OME,890AP,15,A -19-11FEB97-4/12

NOTE: Do not remove roll opener assembly from the platform or the bracket (C) from the chain.

8. Remove both cap screws (A), spacers (B) and bracket (C) from lower lift arm on both sides.

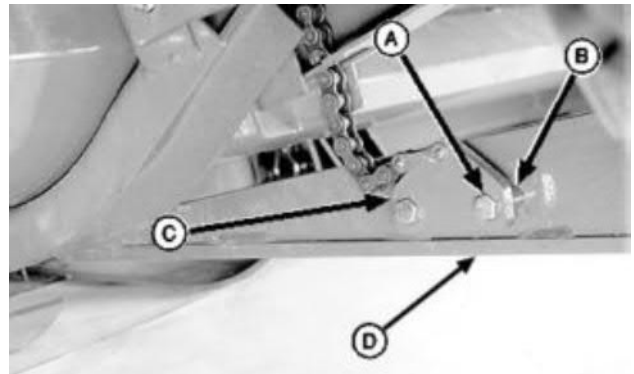

E40702 -JUN-02SEP97

OME,890AP,15,A -19-11FEB97-5/12

Detaching and Attaching the Platform

9. Start windrower and bump platform tilt switch on hydrostatic drive control until the upper link (D) moves without any movement in the platform. Shut off windrower.

10. Remove spring pin (A), pin (B) and guard angle indicator (C). Move upper link assembly (D) upward.

NOTE: Bolt in the hole (E) will hold the upper link assembly up and out of the way.

11. Remove **10x120 mm** bolt from the storage box and position in hole (E).

12. Install spring pin (A), pin (B) and guard angle indicator (C) back on the platform for safe keeping.

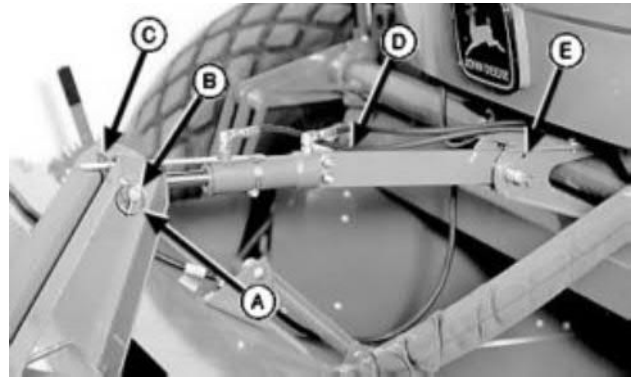

A—Spring Pin
B—Pin
C—Guard Angle Indicator
D—Upper Link
E—Hole

OME,890AP,15,A -19-11FEB97-6/12

Detaching and Attaching the Platform

IMPORTANT: Note the quantity and location of washers, on pivot pins (A), used to position the lift arms in the platform.

NOTE: It may be necessary to gently rock the platform to release any pressure on pivot pins (A) or place jack under each end of knockdown bar.

13. Remove pivot pins (A) and washers from both sides of platform.

IMPORTANT: With engine running, check float pressure. If float pressure does not read zero, repeat STEP 6 in this procedure.

NOTE: When backing the unit, watch the hydraulic hoses connected to the hydraulic motor on the platform.

The hydraulic hoses are the same length so the 16 ft and 18 ft platforms can not move back as far as the 14 ft platform.

14. Start windrower, lower lift arms and backup the windrower, the distances listed below for the different platform lengths, from the platform. Shut off windrower.

- 14 ft platform—762 mm (30 in.)
- 16 ft platform—510 mm (20 in.)
- 18 ft platform—255 mm (10 in.)

15. Install pivot pins (A), washers and cotter pins, removed in step 13, back on platform for safe keeping.

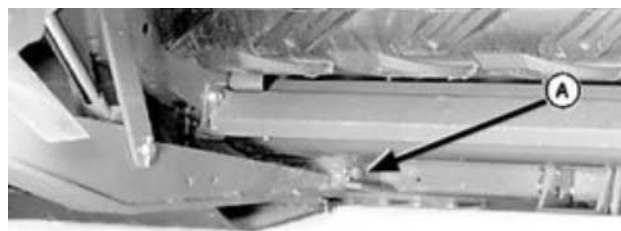

Left-Hand Lift Arm

E40704 -JUN-06AUG96

OME,890AP,15,A -19-11FEB97-7/12

16. Remove two round-head bolts and flange nuts (C).



E42993 -JUN-29JAN97

OME,890AP,15,A -19-11FEB97-8/12

Detaching and Attaching the Platform

17. Lower conditioner drive shield.
18. Remove flange head cap screws (A) and loosen flange head cap screw (B).
19. Pivot shield (C) downward enough for hydraulic motor to clear top of shield.

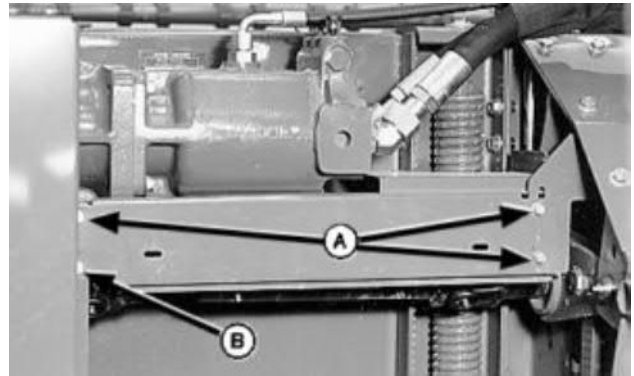

E40705 -JUN-06AUG96

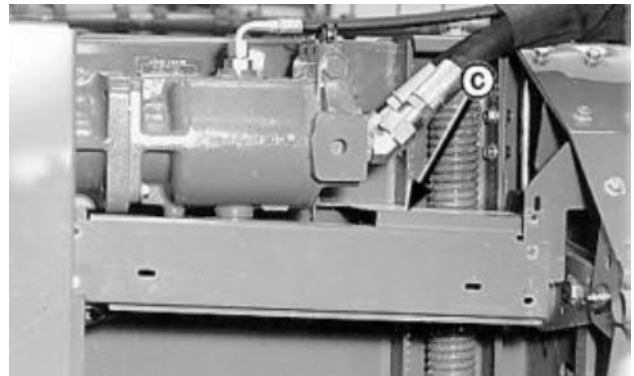

E40706 -JUN-06AUG96

OME,890AP,15,A -19-11FEB97-9/12

20. Remove two upper flange-head bolts (A) and two lower flange-head bolts holding the motor in position.



CAUTION: Use extreme care when removing the hydraulic motor (B). The hydraulic motor weighs 38.5 kg (85 lbs) plus the hydraulic hoses may add additional force to the motor.

21. Move hydraulic motor horizontally away from the gear case, disengaging the splined coupler, allowing it to rest on the ground.
22. Remove splined coupler (C), connecting motor shaft and gearbox shaft, and store in the storage box provided.

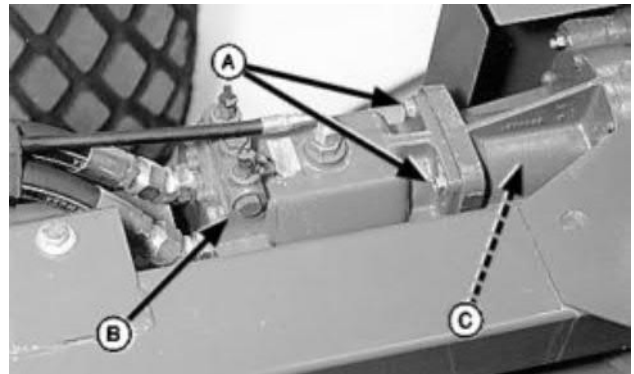

E40707 -JUN-06AUG96

OME,890AP,15,A -19-11FEB97-10/12

Detaching and Attaching the Platform

IMPORTANT: Do not allow the hydraulic motor to drop when moving the windrower.

The windrower is not designed to be transported without the platform attached. To do so may cause rear axle damage and possible loss of steering control.

23. If moving the windrower a short distance on a smooth surface;

Position hydraulic motor (A) on the left front lift arm (B) and hold motor in position with a piece of wire.



E40708 -JUN-06AUG96

OME,890AP,15,A -19-11FEB97-11/12

24. If moving the windrower a long distance on an uneven surface;

Install shipping bracket (A) on the left-hand lift arm (B) with flange head bolts (C) and flange nuts.

Install hydraulic motor in shipping bracket with flange head bolts (D) and flange nuts.

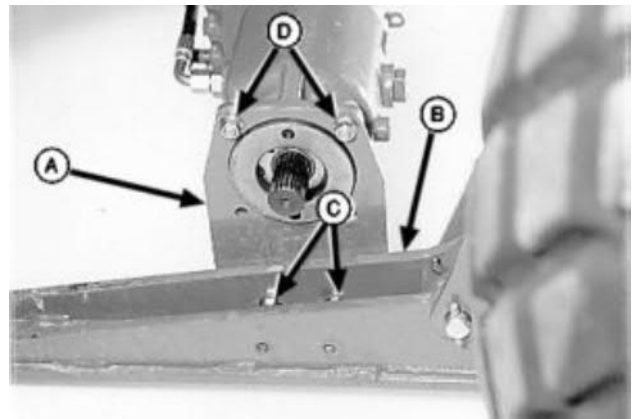

E40708 -JUN-06AUG96

OME,890AP,15,A -19-11FEB97-12/12

ATTACHING THE PLATFORM



CAUTION: To prevent bodily injury it is necessary to read the John Deere 4890 Self-Propelled Windrower operator's manual and familiarize yourself with the operation of the John Deere 4890 Self-Propelled Windrower.

IMPORTANT: To prevent machine damage and insure a properly operating platform, it is necessary to read the John Deere 4890 Self-Propelled Windrower operator's manual and familiarize yourself with the operation of the John Deere 4890 Self-Propelled Windrower.

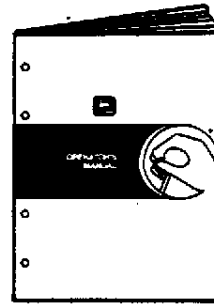

E23482 -JUN-08MAY89

OME,890AP,15,K -19-11FEB97-1/3

CAUTION: When attaching a platform to the windrower, check windrower ballast to insure proper ballast weight is used for the platform. See 'ADDING BALLAST—18' PLATFORM' in the 'Operating the Windrower' section of the 4890 Windrower operator's manual.

IMPORTANT: Float pressure must read ZERO. See Step STEP 6 in 'DETACHING THE PLATFORM' and insure the float pressure knob has been turned counter-clockwise releasing float pressure.

Do not attempt to lift or lower the platform without first setting the float pressure.

To attach the platform to the windrower, reverse Steps 1 through 24 in DETACHING THE PLATFORM in this section with the following special instructions;

NOTE: To completely lower the lift links, it maybe necessary to stand on the lift links when lowering.

1. Move windrower forward to within approx. 762 mm (30 in) of the platform.

IMPORTANT: Prevent lift arms (A) from interfering with the roll separation chains (B).

2. Align lift arms (A) just inside the roll separation chains (B) with the platform sockets (C).
3. Install washers on pivot pins.
4. Apply NEVER-SEEZ® to the end of the splined shaft on the motor and each end of the splined coupler when installing.

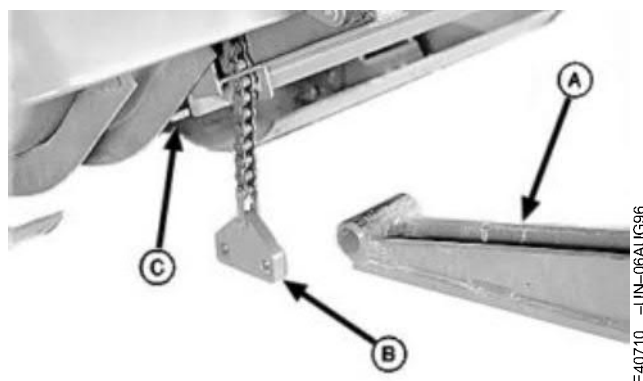

NEVER-SEEZ is a registered trademark of the Emhart Chemical Group.

OME,890AP,15,K -19-11FEB97-2/3



CAUTION: To prevent personal injury or machine damage, close accumulator—platform float valve.

5. After platform installation is complete, close accumulator—platform float valve by turning clockwise.
6. Start engine and push '+' on the platform float pressure switch until the pressure reading is 1200 psi.
7. Check platform balance. See '*BALANCING THE PLATFORM*' in this section of this manual.
8. Start engine and set platform float. See '*ADJUSTING PLATFORM FLOAT*' in the 4890 Windrower operator's manual.

BALANCING THE PLATFORM



Float Pressure Switch

1. Start the windrower, lower platform to the ground and leave engine at idle rpms.
2. Press the '+' on the float pressure switch until the platform starts to raise upward.
3. Note which end of the platform has raised off the ground. If both ends are off the ground, note the end that is the highest off the ground.

NOTE: It may be necessary to remove washers (C) from pins (D) in order to reposition platform on lift arms properly.

4. Raise platform and engage the platform lift lockout lever (A). Shutoff windrower.
5. If necessary, to remove washers (C), remove cotter pins and lift arm retaining pins (D) from both sides of the platform and remove washers.

IMPORTANT: Do not operate platform or platform lift without the lift arm retaining pins (D) properly installed.

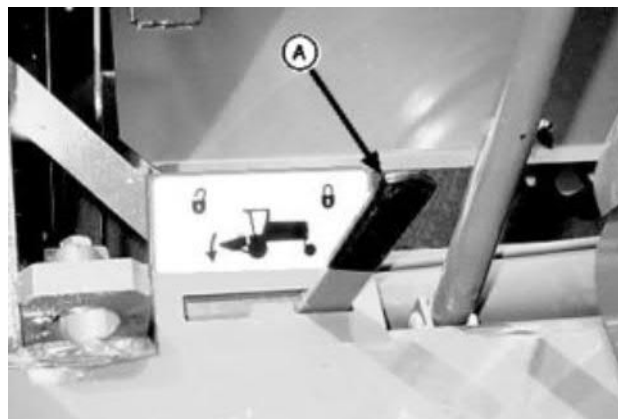

Lockout Lever

6. Install lift arm retaining pins (D) and cotter pins.
7. Start engine, disengage platform lift lockout lever and lower platform to ground.
8. Release float pressure by pressing on the '-' on the float pressure switch until pressure reading is '0' on the cab digital readout.

NOTE: •If left-hand side is higher, steer windrower to the right.

•If right-hand side is higher, steer windrower to the left.

9. Move the windrower a short distance forward while turning in the desired direction.
10. Push the '+' on the platform pressure switch until the pressure reading is 1200 psi. Raise platform and engage the platform lift lockout lever (A). Shut off windrower.

Detaching and Attaching the Platform

11. Remove cotter pins and lift arm retaining pins (D) from both sides of the platform.

IMPORTANT: Do not force washers (C). The washers should be a little loose on the retaining pins

12. Install 1-1/2 x 13/16 x 0.060 washers (C) per side as needed to fill the gap between lift arm (A) and side of lift bracket (B).
13. Install lift arm retaining pins and cotter pins.
14. Start windrower, disengage platform lift lockout and lower platform to the ground. Set platform float, see 'ADJUSTING PLATFORM FLOAT' in the 4890 Windrower operator's manual.

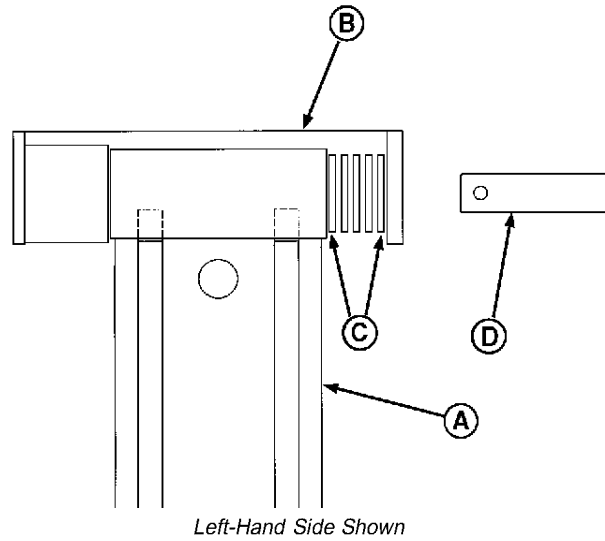

- A—Lift Arm
- B—Lift Bracket
- C—Washers
- D—Pin

E44025 -JUN-13AUG97

EX.03,EX14 -19-13AUG97-2/2

Operating the Auger Platform

PRESTARTING CHECKS

⚠ CAUTION: Never adjust the auger platform with power engaged. Disengage platform drive and shut off windrower.

IMPORTANT: Inspect and service machine before starting work each day with the platform lowered, resting on the ground.

1. Check knife drive arm and pin for looseness.
2. Check oil levels in both knife drives and auger chain drives.
3. Perform required lubrication.
4. Check belts and chains for proper tension and alignment.
5. Inspect cutterbar for broken sections and misaligned guards.
6. Check for loose bolts or missing cotter pins.
7. Check operation of platform lift controls.
8. Check operation of platform warning lights.

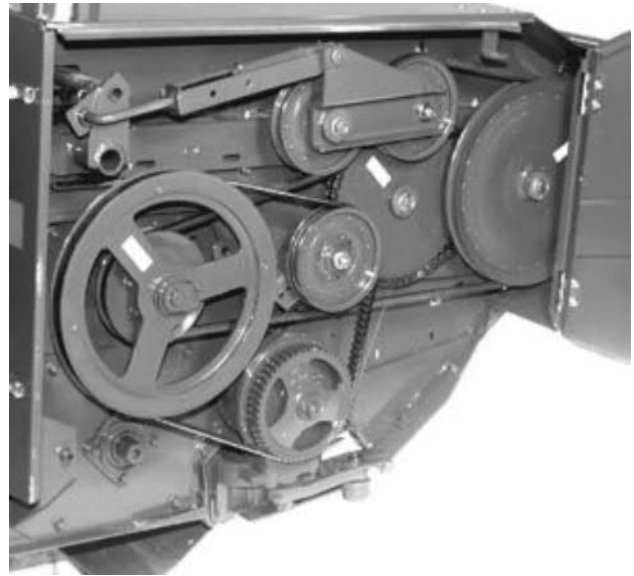

Right-Hand Side

E44072 -UN-23SEP97

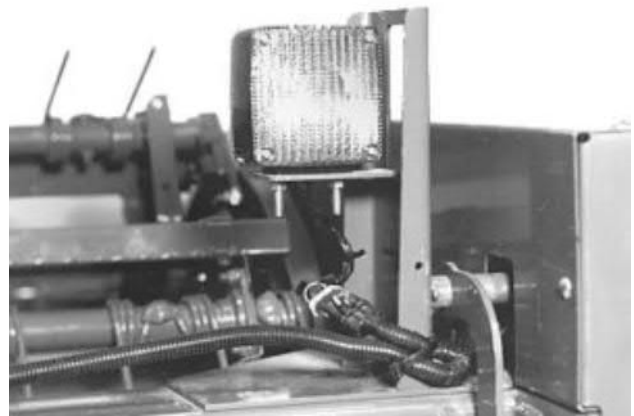

Right-Hand Side

E39916 -UN-18APR96

OME,890AP,20.A -19-06FEB97-1/1

CHECKING KNIFE DRIVE BELT TENSION

Knife drive belt should deflect 6 mm (0.25 in.) when 88 ± 9 N (20 ± 2 lb.) is applied at the center (A) of belt span.

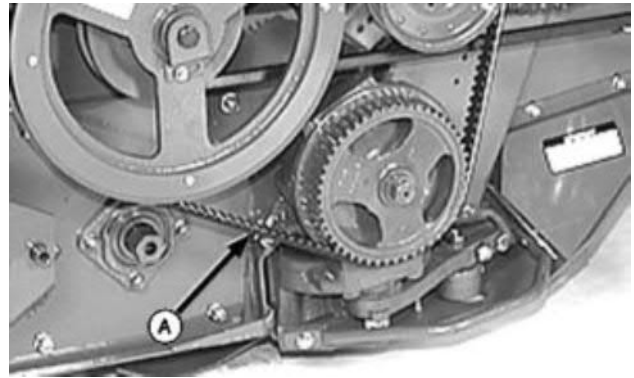

Right-Hand Side

OME,890AP,20,A1 -19-06FEB97-1/1

BREAKING IN THE AUGER PLATFORM



CAUTION: To avoid bodily injury, disengage platform drive and shut off windrower before inspecting platform.

IMPORTANT: After initial break-in, do not operate machine empty for long periods of time to avoid accelerated wear.

1. Run platform empty at slow idle speed for approximately 5 minutes. Disengage platform drive and shut off windrower. Inspect platform for wear or areas needing adjustment.

IMPORTANT: Two major areas of concern are:

1. Stripper to auger adjustment.
 2. Knife sections or hold-downs hot or discolored.
2. Run platform empty at full throttle for approximately 5 minutes. Disengage platform drive and shut off windrower. Inspect platform for wear or areas needing adjustment.

OME,890AP,20,B -19-06FEB97-1/2

Operating the Auger Platform

3. After 8 hours of field operation, check knife drive arm nut (A), knife drive arm bolt (B) and five casting bolts (C) for tightness on both sides of the platform.
4. Tighten knife drive arm nut (A) to 339 N•m (250 lb-ft), Tighten knife drive arm bolt (B) to 271 N•m (200 lb-ft) and tighten five casting bolts (C) to 163 N•m (120 lb-ft).
5. Check knife hold-down clearances. See 'ADJUSTING REGULAR or NON-CLOG HOLD-DOWNS' in Service section of this manual.

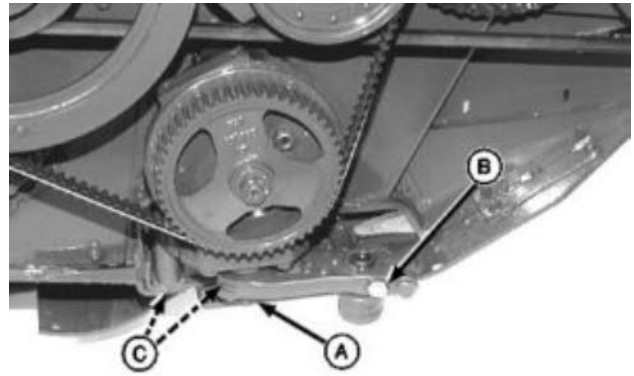

Right-Hand Side

A—Nut
B—Bolt
C—Bolt

E44081 -JUN-23SEP97

OME,890AP,20,B -19-06FEB97-2/2

DETERMINING GROUND SPEED

In most crops the optimum ground speed for cutting is 8—10 kmph (5—6 mph). This will provide good machine productivity, excellent windrow formation and good consistent stubble cutting height. In some conditions the ground speed may be increased to 11 kmph (7 mph). The length of cut stubble will determine if ground speed is too fast.

NOTE: At speeds below 5 kmph (3 mph), smooth windrow formation may be a problem.

Operate platform at recommended engine speed. Running under speed may cause platform to clog when crop is heavy. Where conditions make it necessary to slow ground speed, do not reduce engine speed. Slow ground speed reduces the capacity of the machine and can cause uneven windrows.

Some fields have a predominant "grain" where the material leans or lays in a particular direction. The material will flow through the platform and form a uniform windrow at a fast ground speed when traveling against the grain or against the direction of the lodged crop.

When traveling with the grain, the material may tend to become tangled. The windrow may lose its uniform appearance even at reduced ground speed and stubble may be longer. Uniformity can be improved by selecting travel directions which minimize cutting with the grain.

Depending on crop conditions, a speed of 5 to 11 kmph (3 to 7 mph) will produce a good windrow.

OME,890AP,20,D -19-06FEB97-1/1

KNOCKDOWN BAR

IMPORTANT: No matter how tall or short the crop is, never operate the platform without the knockdown bar installed. The knockdown bar is a structural member of the platform frame.

The knockdown bar will push the crop forward so when it is cut it will feed through the platform and into the conditioner rolls uniformly with the stems first.

The knockdown bar should be adjusted so that it pushes against the crop at approximately a third to one-half of the crop height, holding the crop in position until the reel can pick up the crop and move it across the cutterbar and into the platform. (See 'ADJUSTING THE KNOCKDOWN BAR' in this section of this manual.)

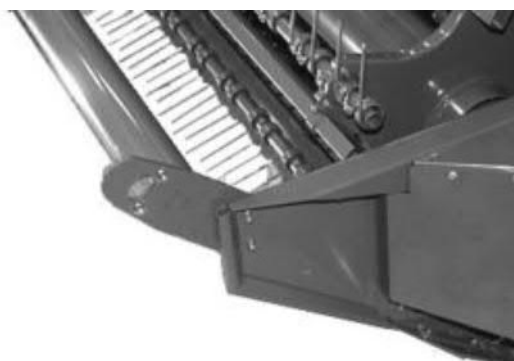

Left-Hand Side

E44065 -JUN-23SEP97



Suggest:

For more complete manuals. Please go to the home page.

<https://www.ebooklibonline.com>

If the above button click is invalid. Please download this document first, and then click the above link to download the complete manual.

Thank you so much for reading

CUTTERBAR KNIFE STORAGE

CAUTION: To reduce risk of personal injury, always wear gloves when handling cutterbar knives (D).

NOTE: Knife storage is provided at both ends of the knockdown bar. Recommend storing the knife for the right-hand side of the cutterbar in the right-hand end of the knockdown bar and the knife for the left-hand side of the cutterbar in the left-hand end of the knockdown bar

1. Remove flange nuts (A), flange-head bolts and knife storage plate (B).

IMPORTANT: Check to be sure the plastic cap is in place in the knife head (C), preventing debris from entering the needle bearings.

2. Position cutterbar knife (D) in the knockdown bar, as shown.
3. Position knife storage plate (B) on knife head (C) as shown. Push cutterbar knife into knockdown bar.
4. With knife storage plate in position, install flange-head bolts and flange nuts (A). Tighten flange nuts.

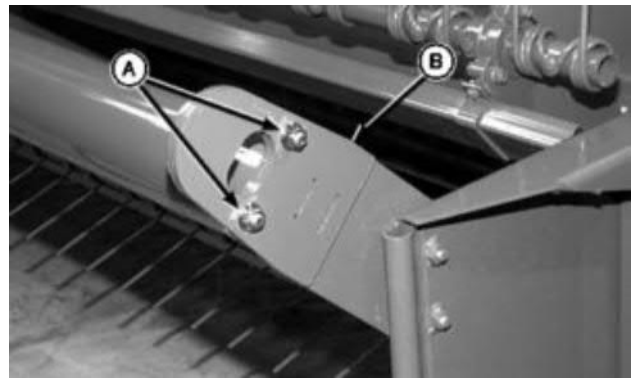

Left-Hand Side

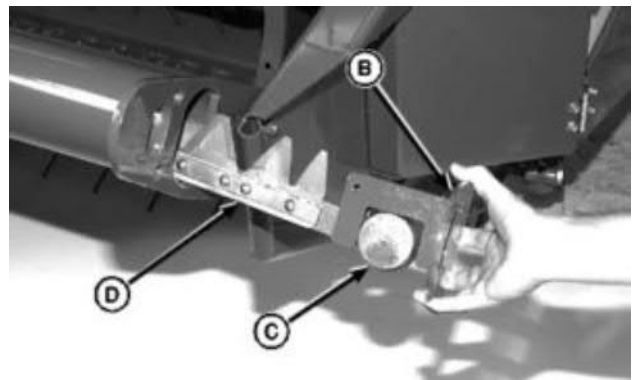

Left-Hand Side

- A—Flange Nuts
- B—Plate
- C—Knife Head
- D—Cutterbar Knife

CUTTERBAR

There cannot be any hesitation of the crop at the cutterbar if a uniform windrow is to be produced. Knife and guard ledger cutting edges sharpness and knife-to-guard fit contribute to a clean cut.

NOTE: Inspect knives and guard ledgers each day before starting.

Dull knives or guard ledgers do not cut all stems cleanly causing an intermixing of cut and uncut stems. This intermix interferes with the flow of the cut stems by the reel, causing rough stubble and an uneven windrow. The poor cutting action also necessitates a slower ground speed.

The cutterbar can be equipped with either regular guards or non-clog guards. Guards without a wear bar must be used at the knife-head at each end of the cutterbar. (See '*INSTALLING REGULAR GUARDS*' or '*INSTALLING NON-CLOG GUARDS*' in the Service section of this manual.)

(CONTINUED)

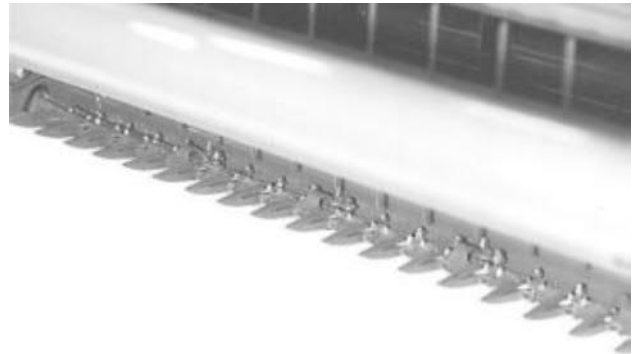

E39866 -JUN-09APR96

<https://www.ebooklibonline.com>

Hello dear friend!

Thank you very much for reading.

Enter the link into your browser.

The full manual is available for immediate download.

<https://www.ebooklibonline.com>