

664 and 666 Row-Crop Headers

(666 From Serial No. 5689)

John Deere Werke Zweibrücken
OMZ92178 Issue E3
(This manual replaces OMCC37426 E2)
European Edition
Printed in Germany
ENGLISCH

Introduction

READ THIS MANUAL carefully to learn how to operate and service your machine correctly. Failure to do so could result in personal injury or equipment damage.

THIS MANUAL SHOULD BE CONSIDERED a permanent part of your machine and should remain with the machine when you sell it.

MEASUREMENTS in this manual are given in both metric and customary U.S. unit equivalents. Use only correct replacement parts and fasteners. Metric and inch fasteners may require a specific metric or inch wrench.

RIGHT-HAND AND LEFT-HAND sides are determined by facing the direction the implement will travel when going forward.

WRITE PRODUCT IDENTIFICATION NUMBERS (P.I.N.) in the Specification or Identification Numbers section. Accurately record all the numbers to help in tracing the machine should it be stolen. Your dealer also needs these numbers when you order parts. File the identification numbers in a secure place off the machine.

BEFORE DELIVERING THIS MACHINE, your dealer performed a predelivery inspection. After operating for the first 100 hours, schedule an after-sale inspection with your dealer to ensure best performance.

THIS ROW-CROP HEADER IS DESIGNED SOLELY for use in customary agricultural or similar operations ("INTENDED USE"). Use in any other way is considered as contrary to the intended use. The manufacturer accepts no liability for damage or injury resulting from this misuse, and these risks must be borne solely by the user. Compliance with and strict adherence to the conditions of operation, service and repair as specified by the manufacturer also constitute essential elements for the intended use.

THIS ROW-CROP HEADER SHOULD BE OPERATED, serviced and repaired only by persons familiar with all its particular characteristics and acquainted with the relevant safety rules (accident prevention). The accident prevention regulations, all other generally recognized regulations on safety and occupational medicine and the road traffic regulations must be observed at all times. Any arbitrary modifications carried out on this row-crop header will relieve the manufacturer of all liability for any resulting damage or injury.

Contents

	Page
Identification View	00-1
Safety	05-1
Safety Decals	10-1
Preparing the Harvester	15-1
Attaching and Detaching	20-1
Transporting	25-1
Operating the Row-Crop Header	30-1
Attachments	35-1
Troubleshooting	40-1
Lubrication and Maintenance	45-1
Service	50-1
Storage	55-1
Specifications	60-1
Serial Number	65-1
Index	

All information, illustrations and specifications in this manual are based on the latest information available at the time of publication. The right is reserved to make changes at any time without notice.

OMZ92178 E3-19-24JUN93

COPYRIGHT© 1993
DEERE & COMPANY
European Office Mannheim
All rights reserved
A John Deere ILLUSTRATION™ Manual

<https://www.ebooklibonline.com>

Hello dear friend!

Thank you very much for reading.

Enter the link into your browser.

The full manual is available for immediate download.

<https://www.ebooklibonline.com>

Contents

Identification View

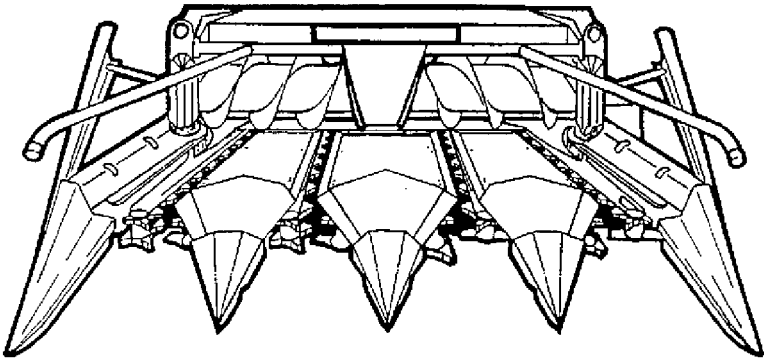

-JUN-31MAR95

CC000250

CC000250

664 Row-Crop Header

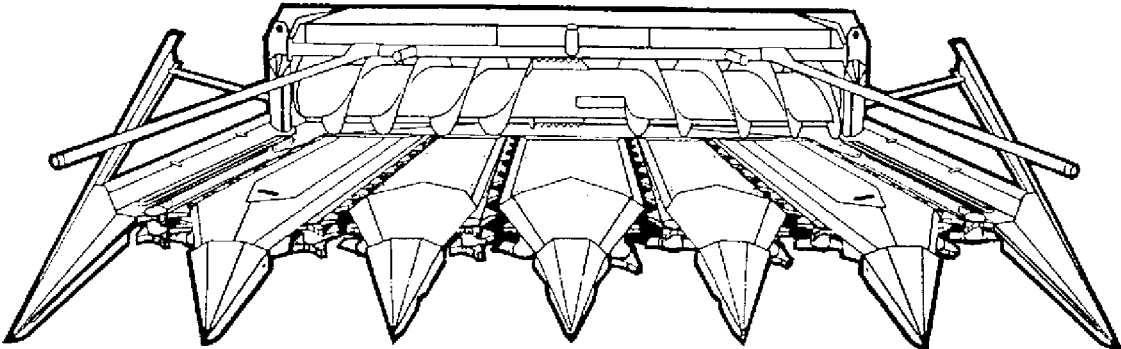

-JUN-31MAR95

CC 000533

CC000533

666 Row-Crop Header

CC,666RC 001051-19-10MAY93

Safety

RECOGNIZE SAFETY INFORMATION

This is the safety-alert symbol. When you see this symbol on your machine or in this manual, be alert to the potential for personal injury.

Follow recommended precautions and safe operating practices.

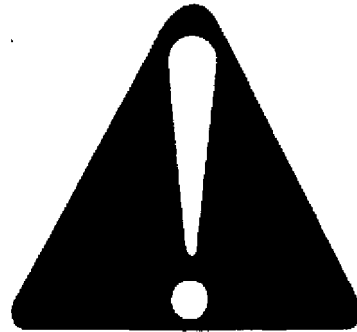

DX,ALERT -19-03MAR93

T81389 -UN-07DEC68

FOLLOW SAFETY INSTRUCTIONS

Carefully read all safety messages in this manual and on your machine safety signs. Keep safety signs in good condition. Replace missing or damaged safety signs. Be sure new equipment components and repair parts include the current safety signs. Replacement safety signs are available from your John Deere dealer.

Learn how to operate the machine and how to use controls properly. Do not let anyone operate without instruction.

Keep your machine in proper working condition. Unauthorized modifications to the machine may impair the function and/or safety and affect machine life.

If you do not understand any part of this manual and need assistance, contact your John Deere dealer.

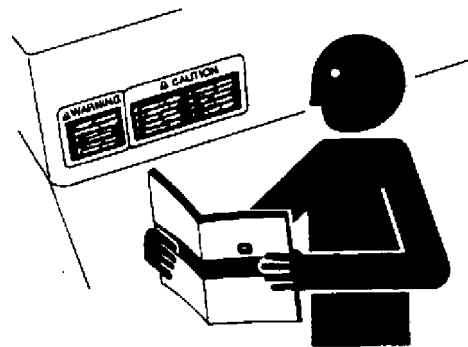

DX,READ -19-03MAR93

T5201 -UN-23AUG88

UNDERSTAND SIGNAL WORDS

A signal word—DANGER, WARNING, or CAUTION—is used with the safety-alert symbol. DANGER identifies the most serious hazards.

DANGER or WARNING safety signs are located near specific hazards. General precautions are listed on CAUTION safety signs. CAUTION also calls attention to safety messages in this manual.



DX,SIGNAL -19-03MAR93

T5187 -19-30SEP88



OBSERVE ROAD TRAFFIC REGULATIONS

Always observe local road traffic regulations when using public roads.



FX,ROAD -19-01MAY91

H28930 -UN-30JUN89

STORE ATTACHMENTS SAFELY

Stored attachments such as dual wheels, cage wheels, and loaders can fall and cause serious injury or death.

Securely store attachments and implements to prevent falling. Keep playing children and bystanders away from storage area.



DX,STORE -19-03MAR93

TS219 -UN-23AUG88

PREPARE FOR EMERGENCIES

Be prepared if a fire starts.

Keep a first aid kit and fire extinguisher handy.

Keep emergency numbers for doctors, ambulance service, hospital, and fire department near your telephone.

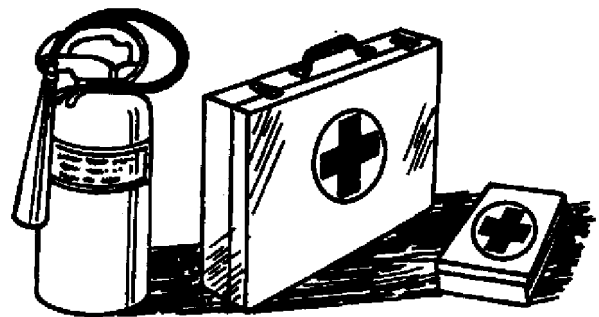

DX,FIRE2 -19-03MAR93

TS291 -UN-23AUG88



WEAR PROTECTIVE CLOTHING

Wear close fitting clothing and safety equipment appropriate to the job.

Prolonged exposure to loud noise can cause impairment or loss of hearing.

Wear a suitable hearing protective device such as earmuffs or earplugs to protect against objectionable or uncomfortable loud noises.

Operating equipment safely requires the full attention of the operator. Do not wear radio or music headphones while operating machine.

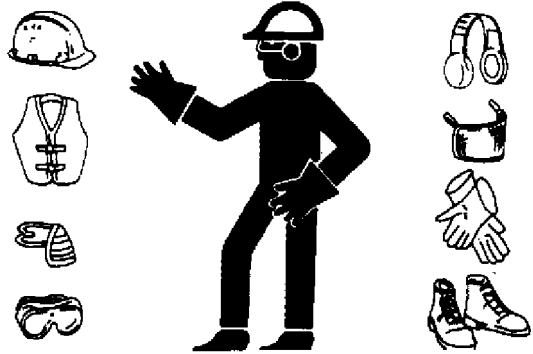

DX,WEAR -19-10SEP90

TS206 -UN-23AUG68

CHECK MACHINE SAFETY

Always check the road and general operating safety of the machine before using.

FX,READY -19-28FEB91

GUARDS AND SHIELDS

Keep guards and shields in place at all times. Ensure that they are serviceable and installed correctly.

Always disengage main clutch, shut off engine and remove key before removing any guards or shields.

Keep hands, feet and clothing away from moving parts.

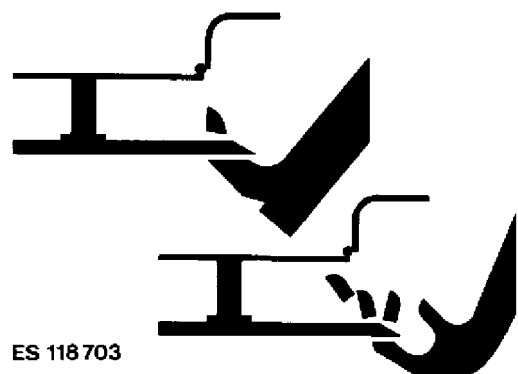

ES 118 703

FX,DEVICE -19-04DEC90

ES118703 -UN-21MAR95



USE SAFETY LIGHTS AND DEVICES

Slow moving tractors, self-propelled equipment and towed implements or attachments can create a hazard when driven on public roads. They are difficult to see, especially at night. Avoid personal injury or death resulting from collision with a vehicle.

Whenever driving on public roads, use flashing warning lights and turn signal according to local regulation. To increase visibility, use the lights and devices provided with your machine. For some equipment, install extra flashing warning lights.

Keep safety items in good condition. Replace missing or damaged items. An implement safety lighting kit is available from your John Deere dealer.

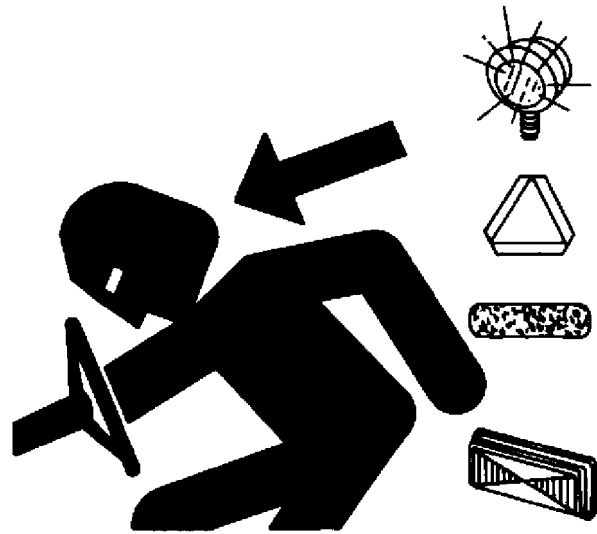

DX,FLASH -19-15MAR93

TS951 -UN-12APR90

KEEP HANDS AWAY FROM KNIVES

Never attempt to clear obstructions in front of or on harvesting unit unless main clutch is disengaged, engine shut off and key removed.

Everyone must be clear of the forage harvester before starting the engine.



FX,KNIFE -19-21DEC90

TS254 -UN-23AUG88



PRACTICE SAFE MAINTENANCE

Understand service procedure before doing work. Keep area clean and dry.

Never lubricate, service, or adjust machine while it is moving. Keep hands, feet, and clothing from power-driven parts. Disengage all power and operate controls to relieve pressure. Lower equipment to the ground. Stop the engine. Remove the key. Allow machine to cool.

Securely support any machine elements that must be raised for service work.

Keep all parts in good condition and properly installed. Fix damage immediately. Replace worn or broken parts. Remove any buildup of grease, oil, or debris.

Disconnect battery ground cable (-) before making adjustments on electrical systems or welding on machine.



DX,SERV -19-03MAR93

-UN-23AUG88

TS218

SERVICE MACHINES SAFELY

Tie long hair behind your head. Do not wear a necktie, scarf, loose clothing, or necklace when you work near machine tools or moving parts. If these items were to get caught, severe injury could result.

Remove rings and other jewelry to prevent electrical shorts and entanglement in moving parts.

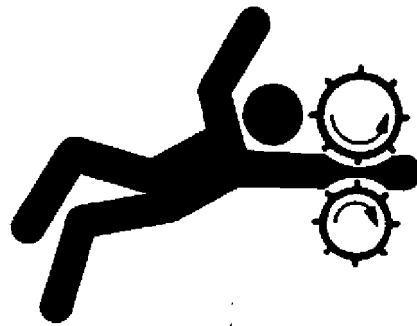

DX,LOOSE -19-04JUN90

-UN-23AUG88

TS228



SUPPORT MACHINE PROPERLY

Always lower the attachment or implement to the ground before you work on the machine. If you must work on a lifted machine or attachment, securely support the machine or attachment.

Do not support the machine on cinder blocks, hollow tiles, or props that may crumble under continuous load. Do not work under a machine that is supported solely by a jack. Follow recommended procedures in this manual.

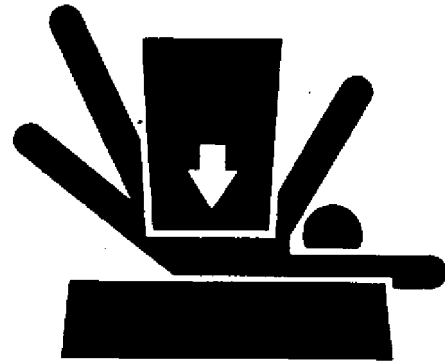

DX,LOWER -19-04JUN90

-UN-23AUG68
TS229

TRANSPORT WITH HARVESTING UNIT INSTALLED

Before driving forage harvester on public roads, harvesting unit must be raised and secured in this position. It must not, however, obstruct operator's view of the road. Remove crop dividers (if equipped) and install protective cover.

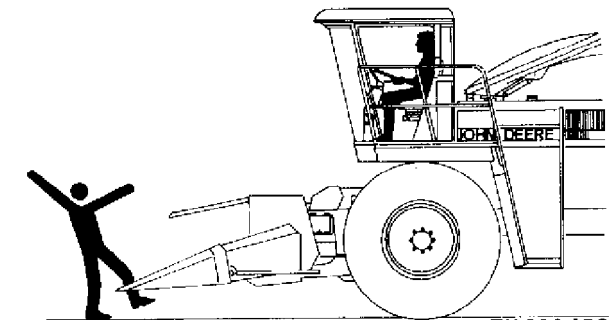

ZX 000452

ZX,HEADER -19-04DEC90

-UN-03APR95
ZX000452

BALLASTING FOR SAFE GROUND CONTACT

Operating, steering and braking performance of forage harvester can be considerably affected by attachments which alter the center of gravity of the machine. To maintain safe ground contact, ballast the harvester at the rear end as necessary. Observe the maximum permissible axle loads and total weights.

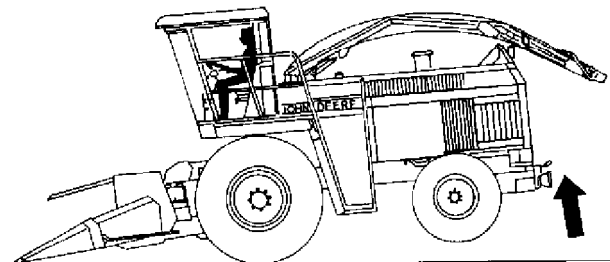

ZX 000453

ZX,WEIGHT -19-02OCT91

-UN-03APR95
ZX000453



REMOVE PAINT BEFORE WELDING OR HEATING

Avoid potentially toxic fumes and dust.

Hazardous fumes can be generated when paint is heated by welding, soldering, or using a torch.

Do all work outside or in a well ventilated area. Dispose of paint and solvent properly.

Remove paint before welding or heating:

- If you sand or grind paint, avoid breathing the dust. Wear an approved respirator.
- If you use solvent or paint stripper, remove stripper with soap and water before welding. Remove solvent or paint stripper containers and other flammable material from area. Allow fumes to disperse at least 15 minutes before welding or heating.

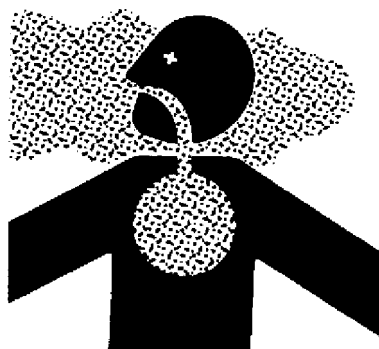

DX,PAINT -19-03MAR93

TS220 -UN-23AUG68

DISPOSE OF WASTE PROPERLY

Improperly disposing of waste can threaten the environment and ecology. Potentially harmful waste used with John Deere equipment include such items as oil, fuel, coolant, brake fluid, filters, and batteries.

Use leakproof containers when draining fluids. Do not use food or beverage containers that may mislead someone into drinking from them.

Do not pour waste onto the ground, down a drain, or into any water source.

Air conditioning refrigerants escaping into the air can damage the Earth's atmosphere. Government regulations may require a certified air conditioning service center to recover and recycle used air conditioning refrigerants.

Inquire on the proper way to recycle or dispose of waste from your local environmental or recycling center, or from your John Deere dealer.

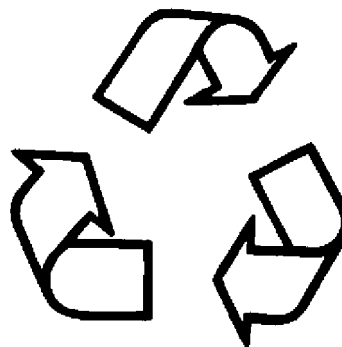

DX,DRAIN -19-03MAR93

TS1133 -UN-26NOV90

Safety Decals

PICTORIAL SAFETY SIGNS

At several important places of this machine safety signs are affixed intended to signify potential danger. The hazard is identified by a pictorial in a warning triangle. An adjacent pictorial provides information how to avoid personal injury. These safety signs, their placement on the machine and a brief explanatory text are shown below.



FX,WBZ -19-19NOV91

TS231 -19-07OCT88

ROW CROP HEADER

DANGER—stay clear of row-crop header. Disengage row-crop header drive, shut off engine and remove key before service or unclogging row-crop header.

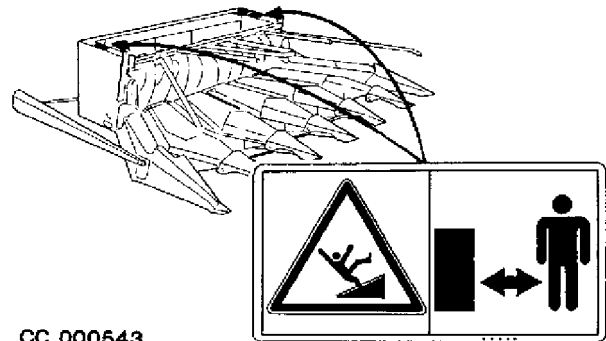

CC 000543

CC.666RC 001091-19-03JUN93

CC000543 -UN-01APR98

DANGER—stay clear of universal drive shaft.

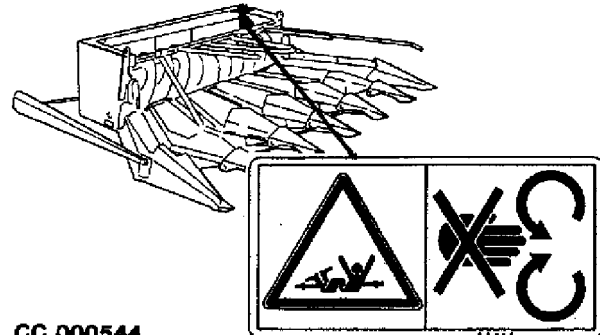

CC 000544

CC.666RC 001092-19-03JUN93

CC000544 -UN-01APR98



Suggest:

For more complete manuals. Please go to the home page.

<https://www.ebooklibonline.com>

If the above button click is invalid. Please download this document first, and then click the above link to download the complete manual.

Thank you so much for reading

Preparing the Harvester

BEFORE ATTACHING THE ROW-CROP HEADER ON SERIES 6000 HARVESTER

The 6610, 6710, 6810 and 6910 harvesters are ready to accept the row-crop header.

Carefully follow all information given in Harvester Operator's Manual for the ballasting, choice of row-crop drive speed, float adjustment and installing attaching frame on harvester.

IMPORTANT: Before attaching row-crop header on harvester, be sure that extensions (A) are removed from the two arms (B). These two extensions (A) are needed for the 645 Windrow Pickup only. If extensions are not removed, it will not be possible to install row-crop header on harvester.

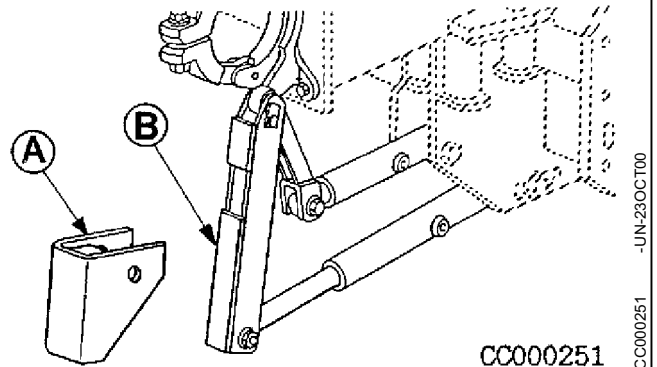

CC000251 -JUN-23-OCT100

CC.666RC 001052-19-10MAY93

BEFORE ATTACHING THE 664 ROW-CROP HEADER ON SERIES 5000 HARVESTER EQUIPPED WITH STANDARD FLOAT SPRINGS

When installing the 664 row-crop header for the first time or removing the harvesting unit prior to attaching another unit, proceed as follows:

IMPORTANT: If another harvesting unit is attached, raise the cutterhead assembly until a pin or bolt can be placed in lockout hole (B) to relieve pressure on springs (A). The springs must be locked out whenever springs or harvesting unit are removed from harvester.

After springs (A) are locked out, remove the harvesting unit and block up cutterhead assembly.

Remove standard float spring assemblies (A) from the harvester by pulling out pins (C).

Install pivot pins (D) in arms and secure with tubular spring pins.

Slide heavy-duty float springs (E) through pivot pins (D).

Attach spring adapter to harvester using drilled pins (F) and spring locking pins.

- A—Spring
- B—Lockout hole
- C—Pin
- D—Pivot pin
- E—Spring
- F—Drilled pin
- G—Balancing spring

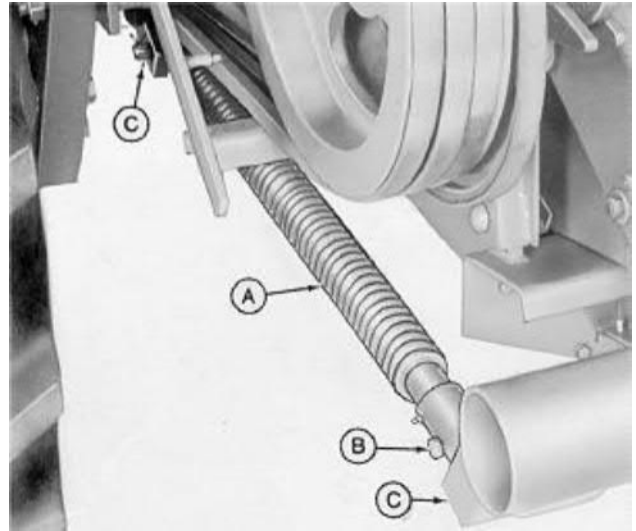

E13861 -JUN-22SEP88

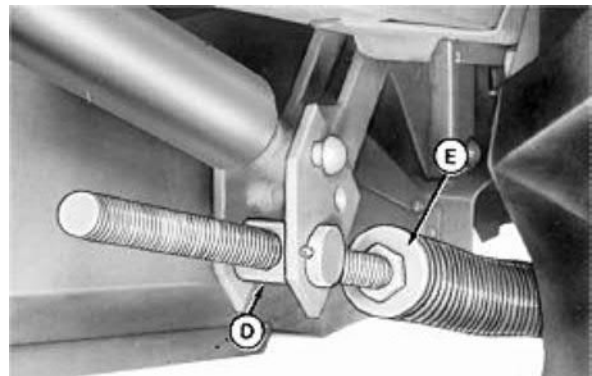

E19148 -JUN-15JUN89

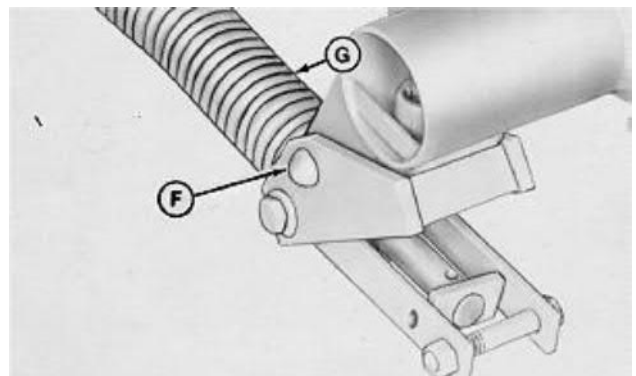

E19149 -JUN-15JUN89

CC.665WRC000987-19-26APR93

<https://www.ebooklibonline.com>

Hello dear friend!

Thank you very much for reading.

Enter the link into your browser.

The full manual is available for immediate download.

<https://www.ebooklibonline.com>