

300 Auger Platform 31, 36, 61 and 66 Hay Conditioners



JOHN DEERE

OPERATORS MANUAL

300 Auger Platform 31, 36, 61 and 66
Hay Conditioners

OME75019 Issue I8 English

John Deere Ottumwa Works
OME75019 Issue I8
(This manual replaces OME75019 Issue I5)

LITHO IN U.S.A.
ENGLISH



Contents

	Page		Page
Safety	05-1	Care of Chains	35-3
Transporting	10-1	Care of V-Belts	35-4
Operating the Auger Platform		Auger and Reel Speeds	35-5
Before Operating Checks	15-1	Changing Auger Speed	35-5
Breaking in the Auger Platform	15-1	Adjusting Auger Drive Chain Tension	35-6
Determining Starting and Ground		Changing Reel Speed	35-6
Speed	15-2	Adjusting Reel Drive Chain Tension	35-7
Knife Overlap	15-2	Adjusting Auger to Deck Clearance	35-7
Producing Uniform Windrows	15-3	Adjusting Auger to Stripper Clearance	35-8
Cutterbar	15-3	Adjusting Auger Slip Clutch	35-8
Knife Hold-Downs	15-4	Slipping Auger Slip Clutch	35-10
Platform Guard Angle and Gauge Shoes	15-4	Additional Auger Flaps	35-11
Reel	15-5	Adjusting Reel Clutch	35-11
Auger	15-6	Adjusting Reel Vertically	35-12
Conditioner	15-6	Adjusting Reel Front-To-Rear	35-12
Platform Float	15-7	Adjusting Cam	35-13
Ground Speed	15-7	Adjusting Cam Followers	35-14
Cutting Alfalfa	15-8	Replacing Reel Teeth in Right-Hand	
Cutting Grass	15-9	and Center Section	35-15
Cutting Tall Crop	15-10	Replacing Reel Teeth in Left-Hand	
Dirt or Mud Buildup	15-11	Section	35-16
Adjusting Platform Float	15-11	Adjusting Conditioner Drive Belt	
Adjusting Platform Guard Angles	15-12	(31 and 61)	35-19
Adjusting Conditioner Roll Pressure	15-12	Adjusting Roll Timing (31 and 61)	35-19
Adjusting Roll Spacing	15-13	Adjusting Conditioner Drive Belt	
Attachments		(36 and 66)	35-20
Double Gauge Shoes	20-1	Adjusting Upper Roll Drive Chain	
Tall Stubble Gauge Shoes	20-1	(36 and 66)	35-20
Gauge Wheels (3430 Windrower)	20-1	Adjusting Lower Roll Drive Chain	35-20
Additional Reel Bats	20-1	Adjusting Roll Timing (36 and 66)	35-21
Cutterbar Knife Sections	20-2	Adjusting Knife Drive Belt (Both	
Non-Clog Cutting Parts	20-2	Sides)	35-21
Tall Crop Dividers	20-2	Removing Knives	35-22
Tall Crop Kit	20-2	Installing Standard Guards on Right-Hand	
Slow-Down Sprocket	20-3	Cutterbar	35-23
Deck Sheets	20-3	Installing Standard Guards on Left-Hand	
Auger Shield	20-3	Cutterbar	35-24
Ruber Auger Flaps	20-3	Installing Non-Clog Guards on Right-Hand	
Lubrication and Maintenance	25-1	Cutterbar	35-25
Troubleshooting	30-1	Installing Non-Clog Guards on Left-Hand	
Service		Cutterbar	35-26
Practice Safe Service Procedures	35-1	Installing Center Guard on Standard	
Inch Series Torque Chart	35-1	Cutterbar	35-27
Tightening Bearing Locking Collars	35-2	Installing Center Guard on Non-Clog	
Installing O-Ring Connector Link	35-2	Cutterbar	35-27
		Adjusting Cutterbar	35-27
		Adjust Regular Knife Hold-Downs	35-28
		Adjust Non-Clog Knife Hold-Downs	35-28
		Cutterbar Knife Sections	35-29
		Sharpening Knife Sections	35-29
		Installing Knives	35-30

Contents

	Page
Adjusting Windrow Width	35-30
Adjusting Forming Shield Height	35-31
Removing Rock Door	35-31
Adjusting Gauge Shoes	35-31
Adjusting Gauge Wheels on 14 and 16 Ft Platforms	35-31
Replacing Auger Drive Chain	35-32
Storage	40-1
Crime Prevention Tips	45-1
Assembly	50-1
Specifications	55-1
Index	60-1

<https://www.ebooklibonline.com>

Hello dear friend!

Thank you very much for reading.

Enter the link into your browser.

The full manual is available for immediate download.

<https://www.ebooklibonline.com>

Safety

RECOGNIZE SAFETY INFORMATION

This is the safety-alert symbol. When you see this symbol on your machine or in this manual, be alert to the potential for personal injury.

Follow recommended precautions and safe operating practices.

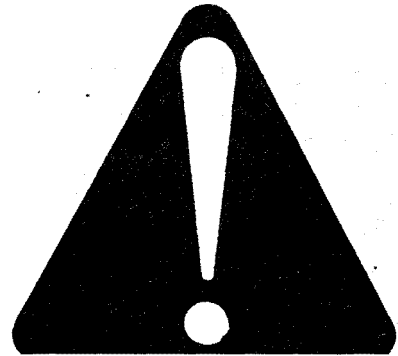

AB6;T81389 053;ALERT 160687

UNDERSTAND SIGNAL WORDS

A signal word—DANGER, WARNING, or CAUTION—is used with the safety-alert symbol. DANGER identifies the most serious hazards.

Safety signs with signal word DANGER or WARNING are typically near specific hazards.

General precautions are listed on CAUTION safety signs. CAUTION also calls attention to safety messages in this manual.



AB6;TS187 053;SIGNAL 071085

FOLLOW SAFETY INSTRUCTIONS

Carefully read all safety messages in this manual and on your machine safety signs. Keep safety signs in good condition. Replace missing or damaged safety signs.

Learn how to operate the machine and how to use controls properly. Do not let anyone operate without instruction.

Keep your machine in proper working condition. Unauthorized modifications to the machine may impair the function and/or safety and affect machine life.



AB6;TS201 053;READ 230487



BEFORE OPERATING

Become familiar with operator's manual, machine decals, and Safety section of this manual.

Remove foreign objects from machine.

Become familiar with all controls effecting machine functions.

Make sure everyone is clear of the machine. Never allow riders on machine or near machine while it is running.

Be sure shields and guards are in place and in good condition before starting. Some powerline and hookup shields are designed to stop rotating upon contact while the shaft continues to rotate.

Check rotating shields to ensure they are free to turn. Make necessary repairs if these shields will not turn.

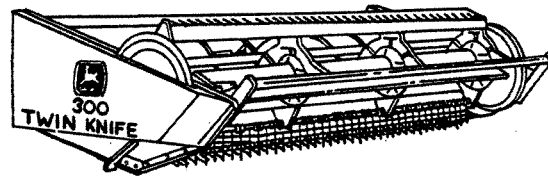
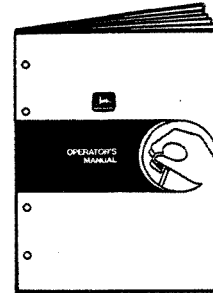

AA7;E23482 E25221 E05;;300AC D 051084

WEAR PROTECTIVE CLOTHING

Wear close fitting clothing and safety equipment appropriate to the job.

Prolonged exposure to loud noise can cause impairment or loss of hearing.

Wear a suitable hearing protective device such as earmuffs or earplugs to protect against objectionable or uncomfortable loud noises.

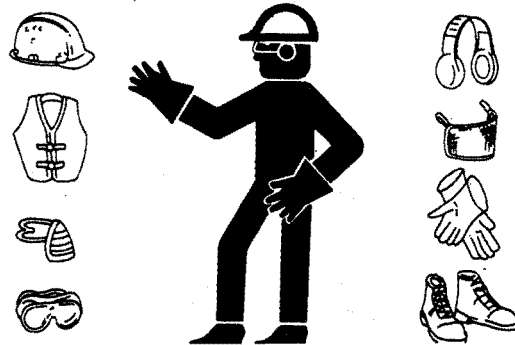

AB6;TS206 053;WEAR 230487

USE SAFETY LIGHTS AND DEVICES

When transporting your machine on a road or highway at night or during the day, use necessary safety lights. Check local governmental regulations. A safety lighting kit is available from your John Deere dealer.

Keep safety items in good condition. Replace missing or damaged items.

A—Lights

C—Reflector Tape

B—Slow Moving Vehicle Emblem

D—Reflectors

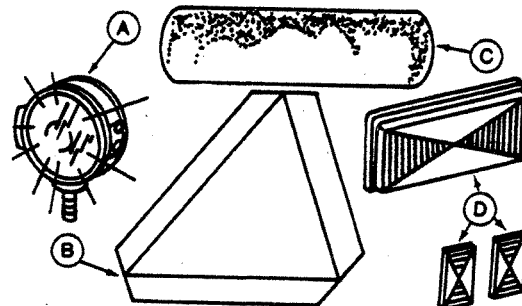

AB6;N36564 053;WARN 070188



Suggest:

For more complete manuals. Please go to the home page.

<https://www.ebooklibonline.com>

If the above button click is invalid. Please download this document first, and then click the above link to download the complete manual.

Thank you so much for reading



PRACTICE SAFE MAINTENANCE

Understand service procedure before doing work. Keep area clean and dry.

Never lubricate or service machine while it is moving. Keep hands, feet, and clothing from power-driven parts. Disengage all power and operate controls to relieve pressure. Lower equipment to the ground. Stop the engine. Remove the key. Allow machine to cool.

Securely support any machine elements that must be raised for service work.

Keep all parts in good condition and properly installed. Fix damage immediately. Replace worn or broken parts. Remove any buildup of grease, oil, or debris.



AB6;TS218 E05;;300AC -H 120888

AVOID HIGH-PRESSURE FLUIDS

Escaping fluid under pressure can penetrate the skin causing serious injury. Relieve pressure before unhooking hydraulic or other lines. Tighten all connections before applying pressure. Keep hands and body away from pinholes and nozzles which eject fluids under high pressure. Use a piece of cardboard to search for leaks.

If ANY fluid is injected into the skin, it must be surgically removed within a few hours by a doctor familiar with this type injury or gangrene may result.

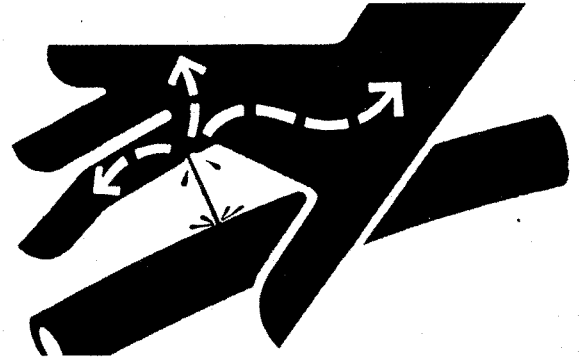

AB6;X9811 053;FLUID 180987

STORE ATTACHMENTS SAFELY

Stored attachments such as dual wheels, cage wheels, and loaders can fall and cause serious injury or death.

Securely store attachments and implements to prevent falling. Keep playing children and bystanders away from storage area.



AB6;TS219 053;STORE 120487

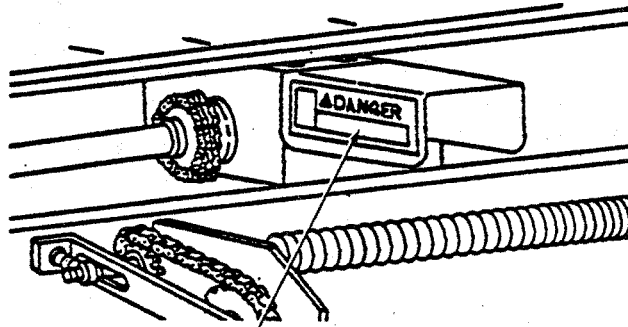

	⚠ DANGER
	Entanglement in rotating driveline can cause serious injury or death. Keep all shields in place. Avoid contact with rotating parts.

085:E32318 E05:300AC -1 120888

<https://www.ebooklibonline.com>

Hello dear friend!

Thank you very much for reading.

Enter the link into your browser.

The full manual is available for immediate download.

<https://www.ebooklibonline.com>