

Operator's Manual

ZAXIS

130-6N

160LC-6N·180LC-6N

210-6N·210LC-6N

250LC-6N

300LC-6N

350LC-6N·380LC-6N

Hydraulic Excavator

Serial No.

ZX130-6N	140001 and up
ZX160LC-6N	240001 and up
ZX180LC-6N	540001 and up
ZX210-6N, 210LC-6N	340001 and up
ZX250LC-6N	440001 and up
ZX300LC-6N	840001 and up
ZX350LC-6N	940001 and up
ZX380LC-6N	640001 and up

INDEX

MACHINE NUMBERS

SAFETY

SAFETY SIGNS

NAME OF COMPONENTS

GETTING ON/OFF THE MACHINE

OPERATOR'S STATION

BREAK-IN

OPERATING THE ENGINE

DRIVING THE MACHINE

OPERATING THE MACHINE

TRANSPORTING

MAINTENANCE

MAINTENANCE UNDER SPECIAL ENVIRONMENTAL CONDITIONS

STORAGE

TROUBLESHOOTING

SPECIFICATIONS

OPTIONAL ATTACHMENTS AND DEVICES

INDEX

CONTENTS

MACHINE NUMBERS	1	Avoid Applying Heat to Lines Containing Flammable Fluids.....	S-34
SAFETY	S-1	Precautions for Handling Accumulator and Gas Damper	S-34
Recognize Safety Information	S-1	Remove Paint Before Welding or Heating	S-35
Understand Signal Words.....	S-1	Beware of Asbestos and Silica Dust and Other Contamination	S-35
Follow Safety Instructions.....	S-2	Prevent Battery Explosions	S-36
Prepare for Emergencies.....	S-3	Service Air Conditioning System Safely	S-36
Wear Protective Clothing.....	S-3	Handle Chemical Products Safely.....	S-37
Protect Against Noise	S-4	Dispose of Waste Properly.....	S-37
Inspect Machine	S-4	Never Ride Attachment.....	S-38
General Precautions for the Cab.....	S-5	Notes on Aftertreatment Device	S-38
Use Handholds and Steps	S-6	Precautions for Communication Terminal.....	S-38
Adjust the Operator's Seat.....	S-6	Precautions for Communication Terminal Equipment ...	S-39
Ensure Safety Before Rising from or Leaving Operator's Seat	S-7	Notes on Protection of Operator's Station when the Machine Rolls Over.....	S-41
Fasten Your Seat Belt.....	S-7	SAFETY SIGNS	S-42
Move and Operate Machine Safely.....	S-8	NAME OF COMPONENTS	1-1
Operate Only from Operator's Seat	S-8	Name of Components	1-1
Jump Starting	S-9	GETTING ON AND OFF THE MACHINE	1-2
Keep Riders off Machine	S-9	OPERATOR'S STATION.....	1-3
Precautions for Operations	S-10	About Aftertreatment Device.....	1-3
Investigate Job Site Beforehand	S-11	Cab Features.....	1-6
Install OPG Guard	S-12	Multi Function Monitor	1-7
Restriction of Attachment Installation	S-12	Default Setting.....	1-8
Provide Signals for Jobs Involving Multiple Machines....	S-13	Basic Screen.....	1-9
Confirm Direction of Machine to Be Driven.....	S-13	How to Use Screens.....	1-10
Drive Machine Safely.....	S-14	Displaying Basic Screen	1-10
Avoid Injury from Rollaway Accidents.....	S-16	Hour Meter	1-13
Avoid Injury from Back-Over and Swing Accidents	S-17	Clock.....	1-13
Keep People Clear from Working Area	S-18	Fuel Gauge	1-13
Never Position the Bucket Over Anyone.....	S-18	DEF/AdBlue® Gauge.....	1-14
Avoid Undercutting.....	S-19	DEF/AdBlue® Level Alarm	1-14
Avoid Tipping.....	S-19	Coolant Temperature Gauge	1-15
Never Undercut a High Bank.....	S-20	Operating Status Icon Display.....	1-15
Dig with Caution.....	S-20	Security Functions (Optional)	1-16
Operate with Caution	S-20	Input Password	1-16
Avoid Power Lines.....	S-21	Extending Password Duration Time	1-17
Precautions for Lightning.....	S-21	Alarm Occurrence Screen.....	1-18
Object Handling	S-22	Remedy	1-20
Protect Against Flying Debris	S-22	Urea SCR System Remedy	1-23
Park Machine Safely.....	S-23	Aftertreatment Device.....	1-25
Handle Fluids Safely—Avoid Fires.....	S-23	Aftertreatment Device Condition Display	1-25
Transport Safely	S-24	Aftertreatment Device Manual Regeneration Request	1-26
Practice Safe Maintenance.....	S-25	Manual Regeneration Procedure	1-27
Warn Others of Service Work	S-26	Main Menu.....	1-28
Support Machine Properly.....	S-26	Engine Output Restriction Suspend.....	1-29
Stay Clear of Moving Parts	S-27	Urea SCR System Troubleshooting.....	1-31
Prevent Parts from Flying	S-27	Air Conditioner.....	1-33
Avoid Injury from Attachment Falling Accident	S-28	Circulation Air Mode	1-33
Prevent Burns.....	S-28	Air Conditioner ON/OFF	1-33
Replace Rubber Hoses Periodically.....	S-29	Radio	1-34
Avoid High-Pressure Fluids	S-29		
Prevent Fires.....	S-30		
Evacuating in Case of Fire.....	S-32		
Beware of Exhaust Fumes.....	S-32		
Precautions for Welding and Grinding	S-33		
Avoid Heating Near Pressurized Fluid Lines	S-34		

<https://www.ebooklibonline.com>

Hello dear friend!

Thank you very much for reading.

Enter the link into your browser.

The full manual is available for immediate download.

<https://www.ebooklibonline.com>

CONTENTS

Work Mode	1-35	Overhead Window Wiper and Washer Switch (Optional)	1-101
Attachment Selection	1-35	Numeric Keypad	1-101
Mail (Optional)	1-36	Switch Panel (for Optional Equipments)	1-102
Setting Menu	1-38	Travel Alarm Deactivation Switch (Optional)	1-103
Date and Time	1-39	Swing Alarm Deactivation Switch (Optional)	1-103
Time Adjustment	1-39	Rear Light Switch (Optional)	1-103
Date Adjustment	1-41	Electrical Control Main Switch (Optional)	1-103
Display Mode Setting	1-43	ON/OFF Operation Switch (Optional)	1-103
Attachment Adjustment	1-45	Key Switch	1-104
Flow Rate Adjustment	1-45	Power Boost Switch	1-104
Priority (arm roll-out)	1-47	Horn Switch	1-104
Priority (arm roll-in) (Except ZX350LC-6N, 380LC-6N)	1-49	Electrical Control Main Switch (Optional)	1-105
Attachment Name Input	1-51	ON/OFF Operation Switch (Optional)	1-106
Auto Shut-Down	1-53	AUX Function Lever 3	1-106
Auto Shut-Down: ON/OFF	1-53	Cigar Lighter	1-107
Auto Shut-Down: Setting Time	1-54	Using Cigar Lighter	1-107
Aftertreatment Device Regeneration Inhibited	1-55	Using Cigar Lighter Port as External Power Source	1-107
Setting Procedure	1-55	Cab Light Switch	1-108
Password Change (Optional)	1-57	Installing Fire Extinguisher (Optional)	1-108
Sub Meter	1-61	Pilot Control Shut-Off Lever	1-109
Rear View Camera Monitor	1-63	Engine Stop Switch	1-109
Rear View Camera ON/OFF	1-63	Fuse Box	1-110
Brightness Adjustment	1-65	Auto Air Conditioner	1-111
Language Settings	1-67	Features:	1-111
Lists of Display Language	1-69	Name of Components	1-112
Unit Selection	1-70	Controller Part Name and Function	1-113
Display Item Selection (Rear View Camera OFF)	1-72	Cab Heater Operation	1-115
Main Menu Sequence Change	1-74	Cooling Operation	1-116
Information Menu	1-76	Defroster Operation	1-117
Operation	1-77	Cool Head/Warm Feet Operation	1-117
Fuel Consumption	1-77	Tips for Optimal Air Conditioner Usage	1-118
Breaker Operation	1-79	For Rapid Cooling	1-118
Attachment Operation	1-81	When Windows Become Misty	1-118
Travel Operation	1-83	Off-Season Air Conditioner Maintenance	1-118
Actual operation	1-85	AM/FM Radio Operation	1-119
Maintenance	1-87	Controls on the Radio	1-119
Time Remaining and Maintenance Interval	1-89	Tuning Procedure	1-119
Troubleshooting	1-91	Station Presetting Procedure	1-120
Monitoring	1-93	Station Auto-Presetting Procedure	1-121
Switch Panel	1-95	TONE Control	1-122
Return to Previous Screen Switch (Monitor)	1-96	Audio Input (Optional)	1-123
Return to Basic Screen Switch (Monitor)	1-96	Cab Door Release Lever	1-124
Selector Knob (Monitor)	1-96	Opening/Closing and Removing Cab Inside Window	1-125
Temperature Control Switch/Mode Switch (Air Conditioner)	1-96	Opening Upper Front Window	1-126
AUTO/OFF Switch/Fan Switch (Air Conditioner)	1-96	Removing and Storing Lower Front Window	1-127
AM/FM Selector/Tuning Switch (Radio)	1-97	Opening Side Window	1-128
Power Switch/Volume Control Knob (Radio)	1-97	Opening/Closing Overhead Window	1-129
Engine Control Dial	1-97	Opening/Closing Overhead Window (Clear Hatch: If Equipped)	1-130
Auto-Idle Switch	1-98	Emergency Exit	1-131
Travel Mode Switch	1-98	Adjusting Operator's Seat	1-132
Power Mode Switch	1-99	Seat Height and Angle Adjustment	1-132
Work Light Switch	1-99	Console and Seat Fore-aft Adjustment	1-132
Wiper/Washer Switch	1-100		

CONTENTS

Seat Fore-Aft Adjustment	1-132	OPERATING THE MACHINE.....	5-1
Backrest Adjustment	1-132	Control Lever (ISO Pattern)	5-1
Armrest Adjustment	1-133	Pilot Control Shut-Off Lever	5-2
Adjusting Operator's Seat	1-134	Warming-Up Operation	5-3
Seat Height and Angle Adjustment	1-134	Engine Speed Control.....	5-4
Console and Seat Fore-aft Adjustment.....	1-134	Auto-Idle.....	5-5
Seat Fore-Aft Adjustment	1-134	Auto-Idle ON/OFF	5-6
Suspension Adjustment	1-134	Auto Shut-Down.....	5-7
Backrest Adjustment	1-135	Aftertreatment Device Manual Regeneration	5-10
Armrest Adjustment	1-135	Work Mode	5-12
Adjusting Operator's Seat (Optional).....	1-136	Power Boost Switch.....	5-15
Seat Height and Angle Adjustment	1-136	Power Mode	5-16
Console and Seat Fore-aft Adjustment.....	1-136	Operating Backhoe.....	5-17
Seat Fore-Aft Adjustment	1-136	Shovel.....	5-18
Suspension Adjustment	1-136	Grading Operation.....	5-19
Backrest Adjustment	1-137	Do Not Strike the Ground with Bucket Teeth.....	5-20
Armrest Adjustment	1-137	Avoid Hammer Work.....	5-20
Adjusting Operator's Seat (Optional).....	1-138	Avoid Abusive Operation	5-21
Adjusting Seat Height.....	1-138	Never Move an Object Sideways with the Bucket.....	5-21
Console and Seat Fore-aft Adjustment.....	1-138	Do Not Use Wide Track Shoes on Rough Ground.....	5-22
Seat Fore-Aft Adjustment	1-138	Shackle Hole Usage	5-23
Suspension Adjustment	1-139	Pilot Accumulator Functions.....	5-24
Fore-Aft Position Adjustment of Seat Surface.....	1-139	How to Lower Boom in Case of Emergency and When Engine Stops.....	5-25
Angle Adjustment of Seat Surface.....	1-139	Precautions for After Operations.....	5-26
Backrest Adjustment	1-139	TRANSPORTING	6-1
Armrest Adjustment	1-139	Transporting by Road	6-1
Console Height Adjustment.....	1-140	Loading/Unloading on a Trailer	6-2
Adjusting Procedures.....	1-140	Fastening Machine for Transporting	6-5
Installation and Adjustment of Mirrors	1-141	Unloading	6-5
Seat Belt.....	1-142	Lifting Machine	6-7
Battery Disconnect Switch.....	1-143	MAINTENANCE.....	7-1
Switch Operation	1-143	Correct Maintenance and Inspection Procedures.....	7-1
BREAK-IN	2-1	Layout.....	7-3
Observe Engine Operation Closely.....	2-1	Check the Hour Meter Regularly.....	7-4
Every 8 Hours or Daily.....	2-1	Maintenance Guide Table	7-5
After the First 50 Hours	2-1	Preparations for Inspection and Maintenance	7-7
After the First 100 Hours.....	2-1	Hood and Access Covers.....	7-8
OPERATING THE ENGINE	3-1	ZX130-6N, 160LC-6N, 180LC-6N	7-8
Inspect Machine Daily Before Starting	3-1	Hood and Access Covers.....	7-9
Before Starting Engine	3-2	Maintenance Guide	7-11
Starting the Engine.....	3-3	Periodic Replacement of Parts.....	7-16
Check Instruments After Starting.....	3-7	Kind of Oils.....	7-17
Using Booster Batteries.....	3-8	Recommended Engine Oil.....	7-17
Stopping the Engine	3-10	A. Greasing.....	7-20
Engine Auto-Stop in Extremely Low Temperature.....	3-11	Front Joint Pins	7-20
DRIVING THE MACHINE	4-1	Swing Bearing	7-22
Travel Levers and Pedals.....	4-1	Swing Internal Gear.....	7-23
Travel Mode Switch	4-3	B. Engine.....	7-24
Travel Alarm (Optional)	4-3	Check Engine Oil Level.....	7-24
Operating on Soft Ground	4-4	Change Engine Oil	7-26
Raise One Track Using Boom and Arm	4-4	Replace Engine Oil Filter.....	7-26
Towing Machine a Short Distance.....	4-5	Check and Clean Around the Engine.....	7-28
Operating in Water or Mud	4-6	Replace Oil Separator Element	7-29
Parking the Machine on Slopes.....	4-7	C. Transmission.....	7-30
Parking the Machine	4-7		

CONTENTS

Pump Transmission (Except ZX130-6N)	7-30	EGR Cooler Cleaning	7-102
Swing Reduction Gear	7-31	Check Turbo Charger	7-102
Travel Reduction Gear	7-32	Check and Clean Injector	7-103
D. Hydraulic System	7-34	Check Gas Damper	7-103
Inspection and Maintenance of		Tightening and Retightening Torque of	
Hydraulic Equipment	7-34	Nuts and Bolts	7-103
Check Hydraulic Oil Level	7-38	J. Aftertreatment Device	7-125
Change Hydraulic Oil	7-39	Check and Clean Aftertreatment Device	7-125
Bleed Air from the Hydraulic System	7-41	K. Urea SCR System	7-126
Suction Filter Cleaning	7-42	Check DEF/AdBlue®	7-128
Replace Full-Flow Filter	7-43	Refill DEF/AdBlue®	7-128
Replace Pilot Oil Filter	7-44	Extendable Filler Neck	7-130
Replace Air Breather Element	7-45	Clean Filler Port Strainer	7-131
Check Hoses and Lines	7-46	Change DEF/AdBlue®	7-132
E. Fuel System	7-50	Replace DEF/AdBlue® Supply Module Main Filter	7-133
Recommended Fuel	7-50	MAINTENANCE UNDER SPECIAL ENVIRONMENTAL	
Drain Fuel Tank Sump	7-52	CONDITIONS	9-1
Drain Fuel Pre-Filter	7-53	Maintenance Under Special Environmental	
Replace Fuel Main Filter Element	7-56	Conditions	9-1
Replace Fuel Pre-Filter Element	7-58	STORAGE	10-1
Replace Fuel Solenoid Pump Filter Element	7-58	Storing the Machine	10-1
Check Fuel Hoses	7-60	TROUBLESHOOTING	11-1
F. Air Cleaner	7-61	Troubleshooting	11-1
Clean and Replace Air Cleaner Element (Outer)	7-61	SPECIFICATIONS	12-1
Replace Air Cleaner Element (Inner)	7-63	Specifications	12-1
G. Cooling System	7-64	ZX130-6N	12-1
Check Coolant Level	7-65	Working Ranges (Grouser shoe)	12-2
Check and Adjust Fan Belt Tension	7-67	ZX130-6N	12-2
Change Coolant	7-69	Shoe Types and Applications	12-3
Clean Radiator/Oil Cooler/Inter Cooler Core	7-71	ZX130-6N	12-3
Clean Oil Cooler, Radiator and Inter Cooler		Bucket Types and Applications	12-4
Front Screen	7-73	ZX130-6N	12-4
Clean Air Conditioner Condenser	7-73	Specifications	12-5
Clean Fuel Oil Cooler	7-73	ZX160LC-6N	12-5
H. Electrical System	7-74	Working Ranges (Grouser shoe)	12-6
Battery	7-75	ZX160LC-6N	12-6
Replace Battery	7-78	Shoe Types and Applications	12-7
Replacing Fuses	7-80	ZX160LC-6N	12-7
Fuse Box	7-81	Bucket Types and Applications	12-8
I. Miscellaneous	7-83	ZX160LC-6N	12-8
Check and Replace Bucket Teeth	7-83	Specifications	12-9
Change Bucket	7-89	ZX180LC-6N	12-9
Convert Bucket Connection Into Face Shovel	7-90	Working Ranges (Grouser shoe)	12-10
Adjust Bucket Linkage	7-91	ZX180LC-6N	12-10
Remove Travel Levers	7-92	Shoe Types and Applications	12-11
Check and Replace Seat Belt	7-92	ZX180LC-6N	12-11
Check Windshield Washer Fluid Level	7-93	Bucket Types and Applications	12-12
Check Track Sag	7-94	ZX180LC-6N	12-12
Clean and Replace Air Conditioner Filter	7-97	Specifications	12-13
Check Air Conditioner	7-99	ZX210-6N, 210LC-6N	12-13
Clean Cab Floor	7-101	Working Ranges (Grouser Shoe)	12-14
Retighten Cylinder Head Bolt	7-102	ZX210-6N, 210LC-6N	12-14
Inspect and Adjust Valve Clearance	7-102	Shoe Types and Applications	12-15
Measure Engine Compression Pressure	7-102	ZX210LC-6N	12-15
Check Starter and Alternator	7-102		
Check and Replace EGR Device	7-102		

CONTENTS

ZX210LC-6N	12-15	Hydraulic Breaker, Hydraulic Crusher and	
Bucket Types and Applications	12-16	Quick Coupler.....	13-16
ZX210-6N, 210LC-6N.....	12-16	Piping for Breaker and Crusher	13-17
Specifications.....	12-17	Operational Procedures for Stop Valves and	
ZX250LC-6N	12-17	Selector Valve.....	13-17
Working Ranges.....	12-18	Secondary Relief Pressure Adjustment	13-18
ZX250LC-6N	12-18	Precautions for Breaker Operation.....	13-19
Shoe Types and Applications	12-19	Change Hydraulic Oil and Replace Full-Flow	
ZX250LC-6N	12-19	Filter Element	13-23
Bucket Types and Applications	12-20	Precautions for Crusher Operation	13-24
ZX250LC-6N	12-20	Attachment.....	13-27
Specifications.....	12-21	Allowable Weight Limits of Installed Attachment	13-27
ZX300LC-6N	12-21	Attachments.....	13-29
Working Ranges.....	12-22	Attachment Connection Parts	13-31
ZX300LC-6N	12-22	Precautions for Arm Roll-In/Bucket Roll-In	
Shoe Types and Applications	12-23	Combined Operation	13-32
ZX300LC-6N	12-23	INDEX.....	14-1
Bucket Types and Applications	12-24		
ZX300LC-6N	12-24		
Specifications.....	12-25		
ZX350LC-6N	12-25		
Working Ranges (Grouser Shoe)	12-26		
ZX350LC-6N	12-26		
Shoe Types and Applications	12-27		
ZX350LC-6N	12-27		
Bucket Types and Applications	12-28		
ZX350LC-6N	12-28		
Specifications.....	12-29		
ZX380LC-6N	12-29		
Working Ranges (Grouser Shoe)	12-30		
ZX380LC-6N	12-30		
Shoe Types and Applications	12-31		
ZX380LC-6N	12-31		
Bucket Types and Applications	12-32		
ZX380LC-6N	12-32		
OPTIONAL ATTACHMENTS AND DEVICES.....	13-1		
PAD CRAWLER SHOE	13-1		
Using Pad Crawler Shoe	13-1		
Traveling and Other Cautions.....	13-2		
Transporting.....	13-3		
Precautions for Transporting Machines with			
Pad Crawler Shoes	13-3		
LONG ARM OPERATION.....	13-6		
BLADE	13-7		
Blade Lever	13-7		
Avoid Hitting Blade with Front-End Attachment.....	13-8		
Blade Maintenance	13-9		
Specifications.....	13-10		
ZX130-6N with Blade.....	13-10		
Working Ranges.....	13-11		
ZX130-6N with Blade.....	13-11		
Shoe Types and Applications	13-12		
ZX130-6N with Blade.....	13-12		
Bucket Teeth (Transverse-Type-Pin-Used Type)	13-13		
Attachment Pedal (Hydraulic Breaker) (Optional).....	13-14		
Attachment Pedal (Hydraulic Crusher) (Optional).....	13-15		

MACHINE NUMBERS

The manufacturing Nos. explained in this group is the individual number (serial No.) given to each machine and main components. These numbers are requested when inquiring any information on the machine and/or components. Fill these serial Nos. in the blank spaces in this group to immediately make them available upon request.

Machine

TYPE : _____
 PRODUCT IDENTIFICATION NUMBER : _____

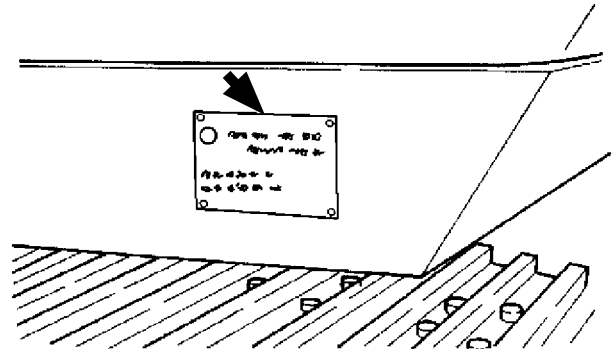

M157-00-001

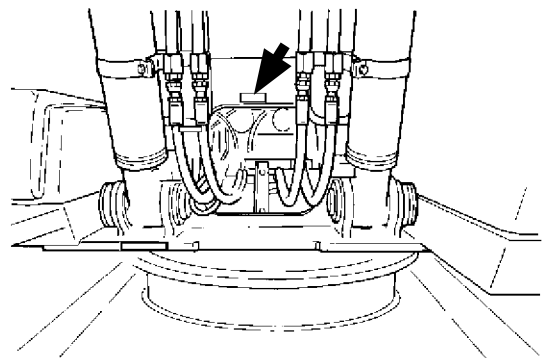

M157-12-008

Product Identification Number



NOTE:

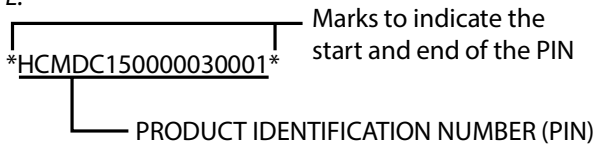

Marks to indicate the start and end of the PIN

PRODUCT IDENTIFICATION NUMBER (PIN)

Engine

TYPE : _____

MFG. NO. : _____

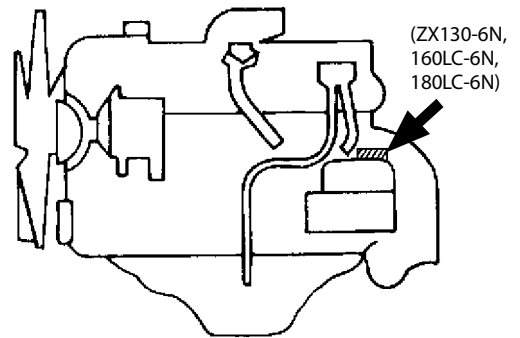

M178-00-002

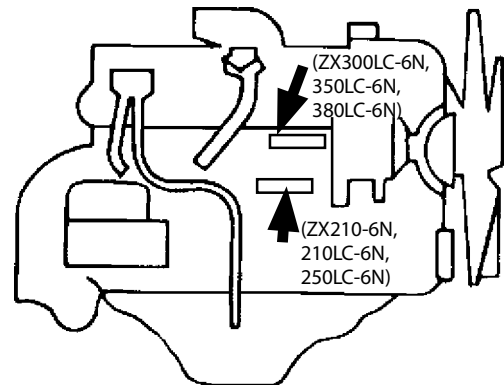

MDAA-00-001

MACHINE NUMBERS

SCR (Selective Catalytic Reduction) Catalyst

TYPE : _____

MFG. NO. : _____

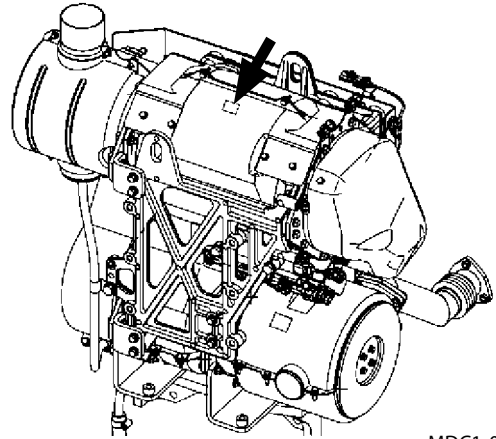

ZX130-6N, 160LC-6N, 180LC-6N

MDC1-00-002

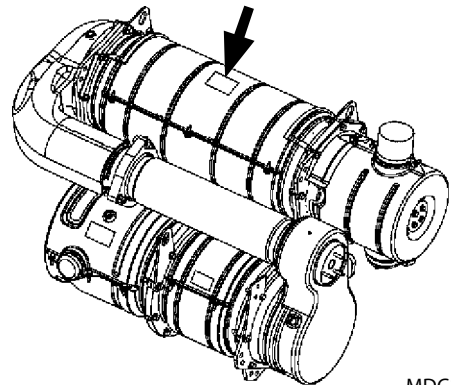

ZX210-6N, 210LC-6N, 250LC-6N

MDC1-00-001

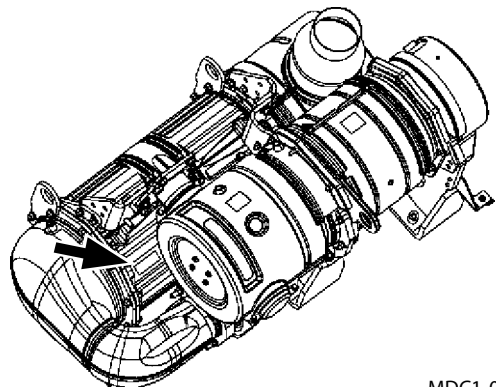

ZX300LC-6N, 350LC-6N, 380LC-6N

MDC1-01-510

MACHINE NUMBERS

DOC (Diesel Oxidation Catalyst)

TYPE : _____

MFG. NO. : _____

TYPE : _____

MFG. NO. : _____

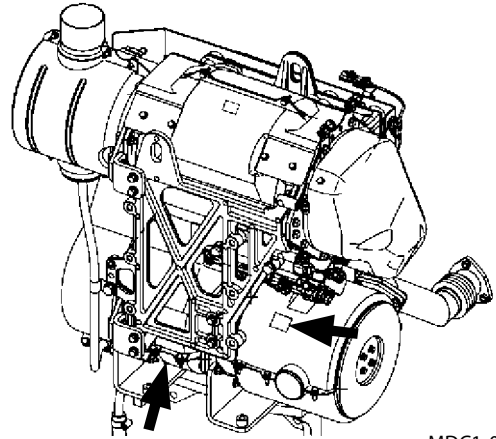

ZX130-6N, 160LC-6N, 180LC-6N

MDC1-00-002

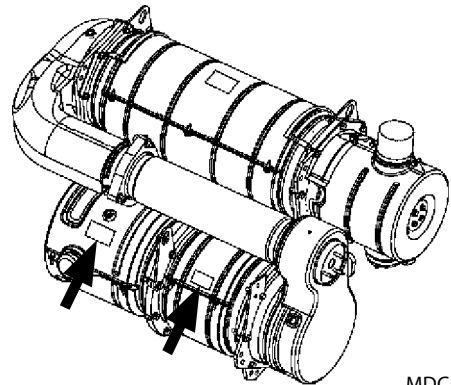

ZX210-6N, 210LC-6N, 250LC-6N

MDC1-00-001

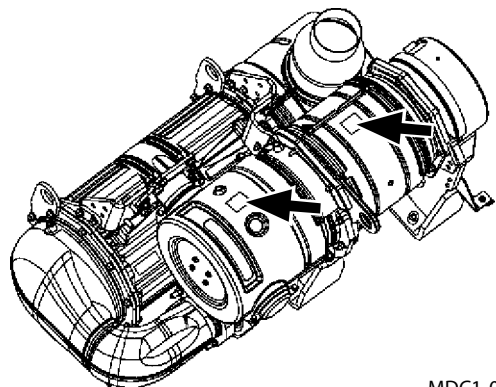

ZX300LC-6N, 350LC-6N, 380LC-6N

MDC1-01-510

MACHINE NUMBERS

Travel Motor

TYPE : _____

MFG. NO. : _____

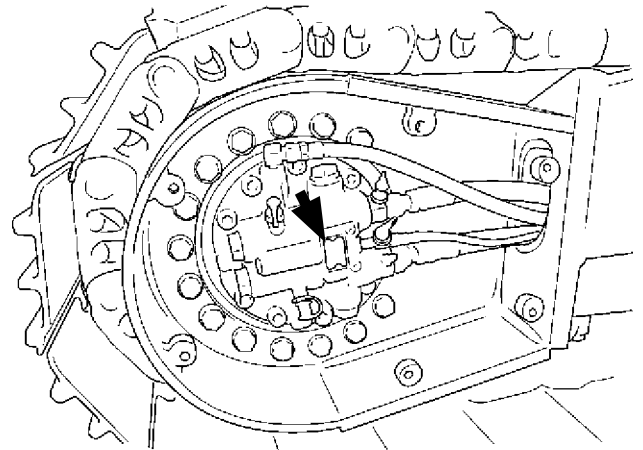

M178-07-047

Swing Motor

TYPE : _____

MFG. NO. : _____

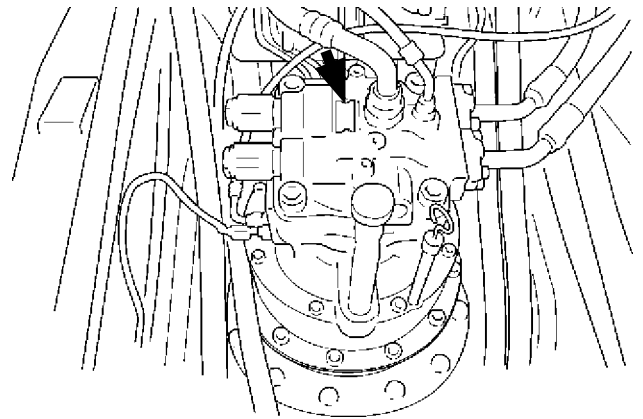

M178-07-086

MACHINE NUMBERS

Hydraulic Pump

TYPE : _____

MFG. NO. : _____

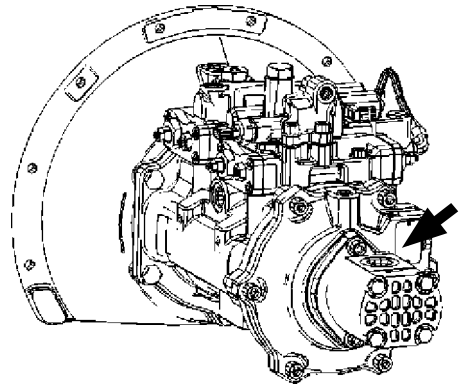

ZX130-6N

MDAA-07-072

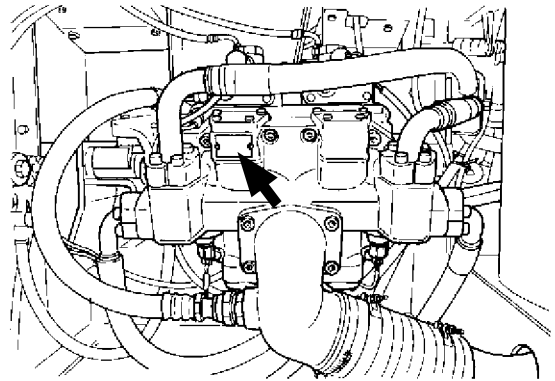

ZX160LC-6N, 180LC-6N

M157-00-004

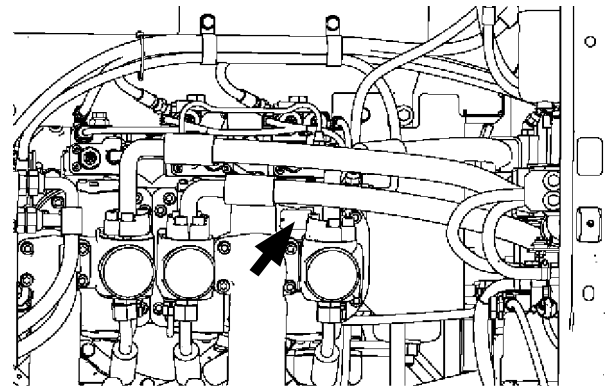

ZX210-6N, 210LC-6N, 250LC-6N, 300LC-6N,
350LC-6N, 380LC-6N

MDAA-00-003

SAFETY

Recognize Safety Information

- These are the **SAFETY ALERT SYMBOLS**.
 - When you see these symbols on your machine or in this manual, be alert to the potential for personal injury.
 - Follow recommended precautions and safe operating practices.

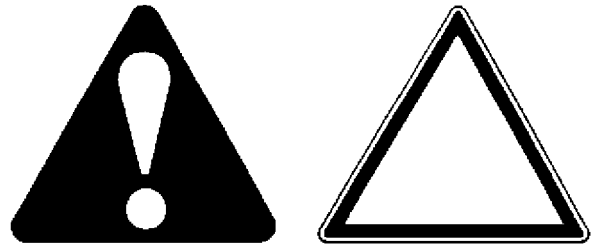

3

Understand Signal Words

- On machine safety signs, signal words designating the degree or level of hazard - DANGER, WARNING, or CAUTION - are used with the safety alert symbol.
 - **DANGER** indicates an imminently hazardous situation which, if not avoided, will result in death or serious injury.
 - **WARNING** indicates a potentially hazardous situation which, if not avoided, could result in death or serious injury.
 - **CAUTION** indicates a potentially hazardous situation which, if not avoided, may result in minor or moderate injury.
 - **DANGER or WARNING safety signs** are located near specific hazards. General precautions are listed on **CAUTION safety signs**.
 - Some safety signs are occasionally used on this machine that do not use any of the designated signal words mentioned above after the safety alert symbol.



IMPORTANT



- To avoid confusing machine protection with personal safety messages, a signal word IMPORTANT indicates a situation which, if not avoided, could result in damage to the machine.
-  **NOTE:** Indicates an additional explanation for a piece of information.

SA-1223

SAFETY

Follow Safety Instructions

- Carefully read and follow all safety signs on the machine and all safety messages in this manual.
- Safety signs should be installed, maintained and replaced when necessary.
 - If a safety sign or this manual is damaged or missing, order a replacement from your authorized dealer in the same way you order other replacement parts (be sure to state machine model and serial number when ordering).
- Learn how to operate the machine and its controls correctly and safely.
- Allow only trained, qualified, authorized personnel to operate the machine.
- Keep your machine in proper working condition.
 - Unauthorized modifications of the machine may impair its function and/or safety and affect machine life.
 - Do not modify any machine parts without authorization. Failure to do so may deteriorate the safety, function, and/or service life of the part. In addition, personal accident, machine trouble, and/or damage to material caused by unauthorized modifications will void Hitachi Warranty Policy.
 - Never attempt to modify or disassemble the inlet/exhaust parts and the aftertreatment device. Avoid shocks to the element of the aftertreatment device, such as striking or dropping objects onto the element. Failure to do so may affect the exhaust gas purifying device, possibly damaging it or lowering its performance.
 - Do not use attachments and/or optional parts or equipment not authorized by Hitachi. Failure to do so may deteriorate the safety, function, and/or service life of the machine. In addition, personal accident, machine trouble, and/or damage to material caused by using unauthorized attachments and/or optional parts or equipment will void Hitachi Warranty Policy.
- The safety messages in this SAFETY chapter are intended to illustrate basic safety procedures of machines. However it is impossible for these safety messages to cover every hazardous situation you may encounter. If you have any questions, you should first consult your supervisor and/or your authorized dealer before operating or performing maintenance work on the machine.

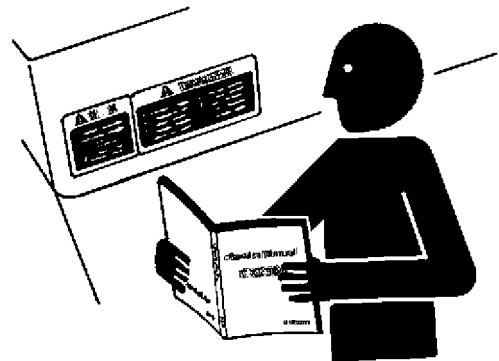

SA-003

SAFETY

Prepare for Emergencies

- Be prepared for a fire or an accident.
 - Keep a first aid kit and fire extinguisher on hand.
 - Thoroughly read and understand the label attached on the fire extinguisher to use it properly.
 - To ensure that a fire extinguisher can be always used when necessary, check and service the fire extinguisher at the recommended intervals as specified in the fire extinguisher manual.
 - Establish emergency procedure guidelines to cope with fires and accidents.
 - Keep emergency numbers for doctors, ambulance service, hospital, and fire department posted near your telephone.

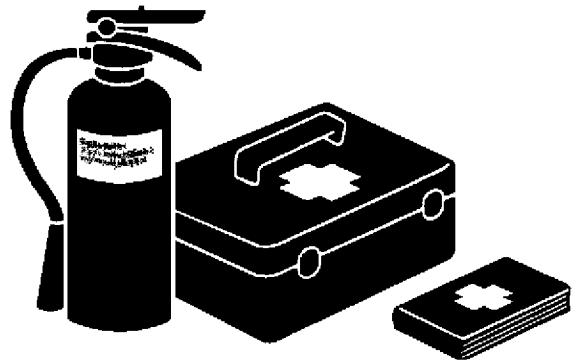

SA-437

Wear Protective Clothing

- Wear close fitting clothing and safety equipment appropriate to the job.

You may need:

- A hard hat
- Safety shoes
- Safety glasses, goggles, or face shield
- Heavy gloves
- Hearing protection
- Reflective clothing
- Wet weather gear
- Respirator or filter mask

Be sure to wear the correct equipment and clothing for the job. Do not take any chances.

- Avoid wearing loose clothing, jewelry, or other items that can catch on control levers or other parts of the machine.
- Operating equipment safely requires the full attention of the operator. Do not wear radio or music headphones while operating the machine.

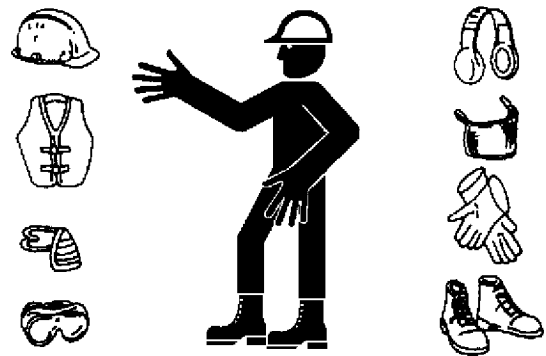

SA-438

SAFETY

Protect Against Noise

- Prolonged exposure to loud noise can cause impairment or loss of hearing.
- Wear a suitable hearing protective device such as earmuffs or earplugs to protect against objectionable or uncomfortably loud noises.



SA-434

Inspect Machine

- Inspect your machine carefully each day or shift by walking around it before you start it to avoid personal injury.
- In the walk-around inspection be sure to cover all points described in the "Inspect Machine Daily Before Starting" section in the operator's manual.



SA-435

SAFETY

General Precautions for the Cab

- Before entering the cab, thoroughly remove all dirt and/or oil such as mud, grease, soil or stones from the soles of your work boots. If any controls such as a pedal is operated while with dirt and/or oil on the soles of the operator's work boots, the operator's foot may slip off the pedal, possibly resulting in a personal accident.
- Do not mess up around the operator's seat with parts, tools, soil, stones, obstacles that may fold up or turn over, cans or lunch box. The levers or pedals become inoperable if obstacle jams in operation stroke of the travel levers/pedals, pilot control shut-off lever or control levers, which may result in serious injury or death.
- Avoid storing transparent bottles in the cab. Do not attach any transparent type window decorations on the windowpanes as they may focus sunlight, possibly starting a fire.
- Refrain from listening to the radio, or using music headphones or mobile telephones in the cab while operating the machine.
- Keep all flammable materials and/or explosives away from the machine.
- After using the ashtray, always cover it to extinguish the match and/or tobacco.
- Do not leave cigarette lighters in the cab. When the temperature in the cab increases, the lighter may explode.
- Correctly lay the floor mat specific to the machine. If another floor mat is used, it may be displaced and contact with the travel pedals during operation, resulting in serious injury or death.

SAFETY

Use Handholds and Steps

- Falling is one of the major causes of personal injury.
 - When you get on and off the machine, always face the machine and maintain a three-point contact with the steps and handrails.
 - Do not use any controls as hand-holds.
 - Never jump on or off the machine. Never mount or dismount a moving machine.
 - Be careful of slippery conditions on platforms, steps, and handrails when leaving the machine.
 - Never get on and off the machine with tools in your hands.

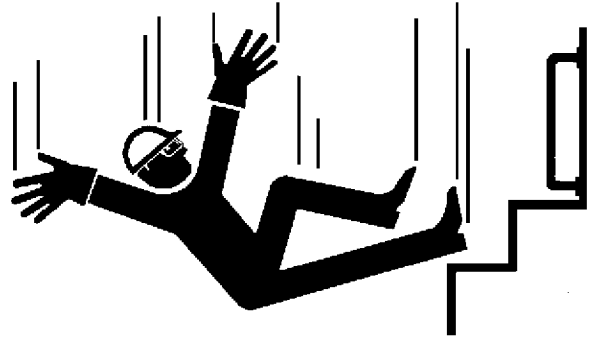

SA-439

Adjust the Operator's Seat

- A seat which is poorly adjusted for the individual operator, or the work to be undertaken, may quickly fatigue the operator leading to misoperation.
 - The seat should be adjusted whenever the operator of the machine changes.
 - The operator should be able to fully depress the pedals and to correctly operate the control levers with his back against the seat back.
 - If not, move the seat forward or backward, and check again.
 - Adjust the rear view mirror position so that the best rear visibility is obtained from the operator's seat. If the mirror is broken, immediately replace it with a new one.



SA-378



Suggest:

For more complete manuals. Please go to the home page.

<https://www.ebooklibonline.com>

If the above button click is invalid. Please download this document first, and then click the above link to download the complete manual.

Thank you so much for reading

SAFETY

Ensure Safety Before Rising from or Leaving Operator's Seat

- Before rising from the operator's seat to open/close either side window or to adjust the seat position, be sure to first lower the front attachment to the ground and then move the pilot control shut-off lever to the LOCK position. Failure to do so may allow the machine to unexpectedly move when a body part unintentionally comes in contact with a control lever and/or pedal, possibly resulting in serious personal injury or death.
- Before leaving the machine, be sure to first lower the front attachment to the ground and then move the pilot control shut-off lever to the LOCK position. Turn the key switch OFF to stop the engine.
- Before leaving the machine, close all windows, doors, and access covers and lock them.

Fasten Your Seat Belt

- If the machine should overturn, the operator may become injured and/or thrown from the cab. Additionally the operator may be crushed by the overturning machine, resulting in serious injury or death.
 - Prior to operating the machine, thoroughly examine webbing, buckle and attaching hardware. If any item is damaged or worn, replace the seat belt or component before operating the machine.
 - Be sure to remain seated with the seat belt securely fastened at all times when the machine is in operation to minimize the chance of injury from an accident.
 - We recommend that the seat belt is replaced every three years regardless of its apparent condition.

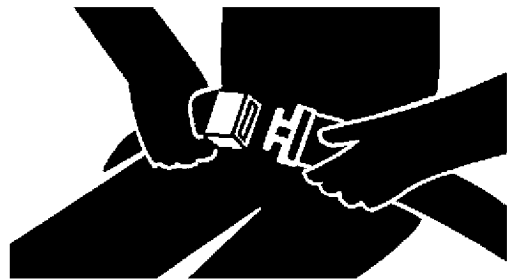

SA-237

SAFETY

Move and Operate Machine Safely

- Bystanders can be run over.
 - Take extra care not to run over bystanders. Confirm the location of bystanders before moving, swinging, or operating the machine.
 - Always keep the travel alarm and horn in working condition (if equipped). It warns people when the machine starts to move.
 - Use a signal person when moving, swinging, or operating the machine in congested areas. Coordinate hand signals before starting the machine.
 - Use appropriate illumination. Check that all lights are operable before operating the machine. If any faulty illumination is present, immediately repair it.
 - Ensure the cab door, windows, doors and covers are securely locked.
 - Check the mirrors and the monitor in the cab for problems.
If there is, replace the problem part (s) or clean the mirror, camera lens and the monitor display.
Refer to Rear View Monitor section for information on cleaning the camera lens and the monitor display.

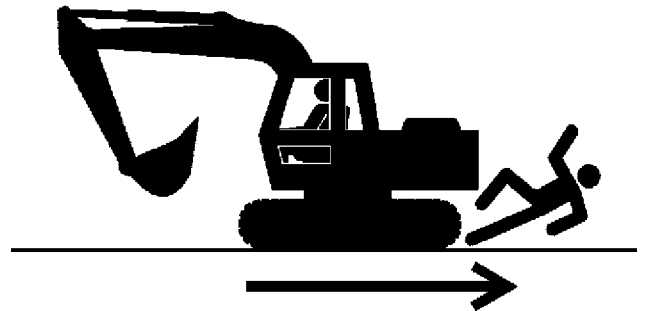

Operate Only from Operator's Seat

- Inappropriate engine starting procedures may cause the machine to runaway, possibly resulting in serious injury or death.
 - Start the engine only when seated in the operator's seat.
 - Never start the engine while standing on the track or ground.
 - Do not start engine by shorting across starter terminals.
 - Before starting the engine, confirm that all control levers are in neutral.
 - Before starting the engine, confirm the safety around the machine and sound the horn to alert bystanders.



SA-444

<https://www.ebooklibonline.com>

Hello dear friend!

Thank you very much for reading.

Enter the link into your browser.

The full manual is available for immediate download.

<https://www.ebooklibonline.com>