

Operator's Manual

ZAXIS

35U-5N

50U-5N

60USB-5N

Hydraulic Excavator

Serial No.
ZX35U-5N 270001 and up
ZX50U-5N 280001 and up
ZX60USB-5N 285001 and up

INDEX

MACHINE NUMBERS

SAFETY

SAFETY SIGNS

COMPONENTS NAME

GETTING ON/OFF THE MACHINE

OPERATOR'S STATION

BREAK-IN

OPERATING THE ENGINE

DRIVING THE MACHINE

OPERATING THE MACHINE

TRANSPORTING

MAINTENANCE

MAINTENANCE UNDER SPECIAL ENVIRONMENTAL CONDITIONS

STORAGE

TROUBLESHOOTING

SPECIFICATION

OPTIONAL ATTACHMENT

INDEX

CONTENTS

MACHINE NUMBERS	1	Avoid Applying Heat to Lines Containing Flammable Fluids	S-32
SAFETY	S-1	Precautions for Handling Accumulator and Gas Damper.....	S-32
Recognize Safety Information	S-1	Remove Paint Before Welding or Heating	S-33
Understand Signal Words.....	S-1	Beware of Asbestos and Silicon Dust and Other Contamination	S-33
Follow Safety Instructions.....	S-2	Prevent Battery Explosions	S-34
Prepare For Emergencies.....	S-3	Precautions for Handling Refrigerant	S-34
Wear Protective Clothing.....	S-3	Handle Chemical Products Safely.....	S-35
Protect Against Noise	S-4	Dispose of Waste Properly.....	S-35
Inspect Machine	S-4	Never Ride Attachment.....	S-36
General Precautions for Cab.....	S-5	Notes for Muffler Filter (ZX50U-5N, 60USB-5N)	S-36
Use Handrails and Steps	S-6	Precautions for Communication Terminal.....	S-36
Adjust the Operator's Seat	S-6	SAFETY SIGNS	S-37
Ensure Safety Before Rising From or Leaving Operator's Seat	S-7	COMPONENTS NAME	1-1
Fasten Your Seat Belt.....	S-7	Components Name	1-1
Move and Operate Machine Safely.....	S-8	GETTING ON/OFF THE MACHINE	1-2
Operate Only From Operator's Seat.....	S-8	Getting ON/OFF the Machine.....	1-2
Jump Starting.....	S-8	OPERATOR'S STATION	1-3
Keep Riders Off Machine	S-9	Muffler Filter (ZX50U-5N, 60USB-5N)	1-3
Precautions for Operations.....	S-9	Layout.....	1-6
Investigate Job Site Beforehand	S-10	Key Switch	1-8
Equipment of OPG.....	S-11	Switch Panel	1-8
Provide Signals for Jobs Involving Multiple Machines....	S-11	Monitor	1-9
Confirm Direction of Machine to be Driven	S-11	Feature	1-9
Drive Machine Safely.....	S-12	Screen Configuration.....	1-9
Avoid Injury From Rollaway Accidents.....	S-14	Basic Screen.....	1-10
Avoid Injury From Back-over and Swing Accidents	S-15	Indicators.....	1-11
Keep Person Clear From Working Area.....	S-16	Overheat Indicator (1)	1-11
Never Position Bucket Over Anyone	S-16	Engine Oil Pressure Indicator (2)	1-11
Avoid Undercutting.....	S-16	Alternator Indicator (3)	1-11
Avoid Tipping.....	S-17	Fuel Level Indicator (4).....	1-11
Never Undercut a High Bank.....	S-17	How to Use Screens.....	1-12
Dig With Caution	S-18	Displaying Basic Screen	1-12
Operate With Caution	S-18	Hour Meter	1-15
Avoid Power Lines.....	S-18	Clock.....	1-15
Precautions For Lightning.....	S-19	Fuel Gauge	1-15
Object Handling	S-19	Coolant Temperature Gauge	1-15
Protect Against Flying Debris	S-20	Operating Status Icon Display.....	1-15
Park Machine Safely.....	S-20	Alarm Occurrence Screen.....	1-16
Handle Fluids Safely -- Avoid Fires.....	S-21	Error Display Screen.....	1-16
Safety Transporting	S-22	Warning Display Screen.....	1-16
Practice Safe Maintenance.....	S-23	Alarm List Display	1-17
Warn Others of Service Work	S-24	Contents of Alarms	1-18
Support Machine Properly.....	S-25	Error Code.....	1-18
Stay Clear of Moving Parts	S-25	Warning Codes	1-18
Prevent Parts From Flying	S-26	DTC Code List	1-20
Store Attachments Safely	S-26	Muffler Filter (ZX50U-5N, 60USB-5N)	1-25
Prevent Burns.....	S-27	Muffler Filter Condition Display.....	1-25
Replace Rubber Hoses Periodically.....	S-28	Muffler Filter Manual Regeneration Request.....	1-26
Avoid High-Pressure Fluids.....	S-28	Main Menu (MENU)	1-28
Prevent Fires.....	S-29	Auto Shut-Down.....	1-29
Evacuating in Case of Fire.....	S-31		
Beware of Exhaust Fumes.....	S-31		
Precautions for Welding and Grinding	S-32		
Avoid Heating Near Pressurized Fluid Lines	S-32		

<https://www.ebooklibonline.com>

Hello dear friend!

Thank you very much for reading.

Enter the link into your browser.

The full manual is available for immediate download.

<https://www.ebooklibonline.com>

CONTENTS

Muffler Filter Regeneration Inhibited (ZX50U-5N, 60USB-5N)	1-31	Using Booster Battery	3-7
Setting Procedure	1-31	Stopping the Engine	3-9
Clock.....	1-34	DRIVING THE MACHINE	4-1
Clock Adjustment	1-34	Travel Levers and Pedals (Optional).....	4-1
Display Mode Setting	1-36	Travel Mode Switch	4-3
Trip.....	1-37	Traveling	4-4
Functions of Trip Meter	1-37	Traveling on Soft Ground	4-5
Displaying Trip Meter (1)	1-38	Raise One Track Using Boom and Arm	4-6
Displaying Trip Meter (2)	1-40	Towing Machine	4-7
Change Trip Meter Set Time	1-41	Operating in Water or Mud.....	4-8
Brightness Adjustment.....	1-43	Precautions for Traveling on Slopes.....	4-9
Heater Operation (ZX35U-5N, 50U-5N).....	1-46	Parking the Machine on Slopes.....	4-10
Name and Function of Each Part of Control Panel.....	1-46	Parking the Machine	4-10
Heating Operation	1-47	OPERATING THE MACHINE	5-1
Defroster Operation.....	1-47	Control Lever (ISO Pattern)	5-1
Tips for Optimal Heater Usage.....	1-48	AUX Function Lever	5-2
When Windows Become Clouded	1-48	Boom-Swing Pedal.....	5-3
Air Conditioner Operation (Optional)	1-49	Blade Lever	5-4
Name and Function of Each Part of Control Panel.....	1-49	Precautions for Blade Operation.....	5-5
Heating Operation	1-50	Pilot Control Shut-Off Lever	5-6
Cooling Operation.....	1-50	Warming Up Operation.....	5-8
Defroster Operation.....	1-50	Engine Speed Control.....	5-9
Tips for Optimal Air Conditioner Usage	1-51	Auto-Idle.....	5-10
For Rapid Cooling	1-51	Auto Shut-Down.....	5-12
When Windows Become Clouded	1-51	Muffler Filter Manual Regeneration.....	5-15
Off-Season Air Conditioner Maintenance.....	1-51	Power Mode	5-17
Radio (Cab equipped machine) (Optional)	1-52	Operating Backhoe.....	5-18
AM/FM Radio Operation (Cab equipped machine)	1-53	Grading Operation.....	5-19
Part Name and Function	1-53	Avoid Abusive Operation	5-20
Radio Operation	1-53	Avoid Excavation Using Upperstructure and/or Boom	
Tuning Procedure	1-54	Swing Power	5-20
Station Presetting Procedure.....	1-54	Avoid Driving Bucket Teeth into Ground.....	5-21
Deletion of Preset Memory	1-54	Avoid Striking With Bucket	5-21
Sound Control	1-55	Boom Cylinder may Hit Blade.....	5-22
Digital Clock Setting Procedure.....	1-55	Avoid Hitting Blade With Bucket.....	5-23
Door Lock Release Lever (Cab equipped machine)	1-56	Avoid Colliding Blade Against Rocks.....	5-23
Opening Upper Front Window (cab equipped machine)	1-57	Avoid Colliding Boom Cylinder With Track.....	5-23
Front Window	1-57	Precautions for Installing Wide Bucket or Special Type	
Removing and Storing Lower Front Window	1-57	Bucket	5-23
Adjusting the Seat.....	1-58	Use Correct Track Shoe.....	5-24
Seat Fore-aft Adjustment.....	1-58	Using Rubber Crawler.....	5-25
Tool Box	1-58	Avoid other than Specified Machine Operations	5-27
Seat Back Box.....	1-58	Shackle Bracket Usage.....	5-28
Emergency Exit (cab equipped machine)	1-59	Emergency Boom Lowering Procedure	5-29
Seat Belt.....	1-60	Precautions for After Operations.....	5-31
Room Lamp (cab equipped machine)	1-60	TRANSPORTING	6-1
BREAK-IN	2-1	Transporting by Road	6-1
Breaking in New Machine	2-1	Loading/Unloading on a Truck.....	6-2
OPERATING THE ENGINE	3-1	Fastening Machine for Transporting	6-5
Inspect Machine Daily Before Starting	3-1	Unloading	6-6
Before Starting Engine	3-2	Lifting Machine	6-7
Starting the Engine.....	3-3	MAINTENANCE	7-1
Check Instruments After Starting Engine.....	3-6	Correct Maintenance and Inspection Procedures.....	7-1
		Check the Hour Meter Regularly.....	7-2

CONTENTS

Layout.....	7-3	Replacing Fuses.....	7-76
Maintenance Guide Table.....	7-4	I. Miscellaneous.....	7-77
Preparations for Inspection and Maintenance.....	7-6	Check and Replace Bucket Teeth.....	7-77
Access Covers.....	7-7	Change Bucket.....	7-79
Maintenance Guide.....	7-10	Adjust Track Sag (Rubber Crawler) and Check for Damage.....	7-80
Periodic Replacement of Parts.....	7-14	Check Rubber Track for Damage.....	7-80
Kind of Oils.....	7-15	Replace Rubber Crawler.....	7-82
A. Greasing.....	7-19	Removing Rubber Crawler.....	7-82
Front Joint Pins.....	7-19	Installing Rubber Crawler.....	7-83
Bucket.....	7-19	Check Track Sag (Steel Crawler) (Optional).....	7-84
Swing Post and Others.....	7-19	Converting the Track.....	7-86
Blade Pins.....	7-21	Check and Replace Seat Belt.....	7-87
Swing Bearing.....	7-22	Check Air Conditioner (Cab Equipped Machine).....	7-88
Swing Internal Gear.....	7-23	Clean and Replace Heater / Air Conditioner Filter.....	7-90
Control Lever Universal Joint.....	7-23	Clean Circulating Air Filter.....	7-90
B. Engine.....	7-24	Replace Circulating Air Filter.....	7-90
Engine Oil Level.....	7-24	Clean Fresh Air Filter.....	7-92
Change Engine Oil.....	7-25	Replace Fresh Air Filter.....	7-92
Replace Engine Oil Filter.....	7-25	Clean Fresh Air Filter.....	7-93
C. Transmission.....	7-28	Replace Fresh Air Filter.....	7-93
Travel Reduction Gear.....	7-28	Clean Cab Floor.....	7-94
D. Hydraulic System.....	7-31	Check, Clean and Function Check of Injection Nozzle (ZX35U-5N).....	7-95
Inspection and Maintenance of Hydraulic Equipment.....	7-31	Inspect and Adjust Valve Clearance.....	7-95
Check Hydraulic Oil Level.....	7-35	Check and Adjust Injection Timing (ZX35U-5N).....	7-95
Drain Hydraulic Oil Tank Sump.....	7-36	Measure Engine Compression Pressure.....	7-95
Change Hydraulic Oil.....	7-37	Check Starter and Alternator.....	7-95
Suction Filter Cleaning.....	7-37	Check Crankcase Breather.....	7-95
Replacement of Full-Flow Filter.....	7-41	Check Radiator Cap.....	7-96
Replace Pilot Oil Filter Element.....	7-43	Clean EGR Cooler (ZX50U-5N/60USB-5N).....	7-96
Check Hoses and Lines.....	7-45	Function Check Intake Throttle Valve (ZX50U-5N/ 60USB-5N).....	7-96
E. Fuel System.....	7-52	Check, Clean and Function Check EGR Valve (ZX50U-5N/60USB-5N).....	7-96
Recommended Fuel.....	7-52	Tightening and Retighten Torque of Bolts and Nuts.....	7-97
Check Fuel Level.....	7-53	J. Muffler Filter (ZX50U-5N, 60USB-5N).....	7-103
Drain Fuel Tank Sump.....	7-54	Check and Clean Filter Element of Muffler Filter.....	7-103
Check Water Separator (ZX35U-5N).....	7-55	Check and Clean Muffler Filter.....	7-103
Bleed Air from Fuel System (ZX35U-5N).....	7-55	MAINTENANCE UNDER SPECIAL ENVIRONMENTAL CONDITIONS.....	9-1
Replace Fuel Main Filter Element.....	7-58	Maintenance Under Special Environmental Conditions.....	9-1
Replace Fuel Pre-Filter Element (ZX50U-5N, 60USB-5N).....	7-59	STORAGE.....	10-1
Check Fuel Hoses.....	7-60	Storing the Machine.....	10-1
F. Air Cleaner.....	7-61	TROUBLESHOOTING.....	11-1
Clean Air Cleaner Outer Element.....	7-61	Troubleshooting.....	11-1
Replace Air Cleaner Outer and Inner Elements.....	7-61	SPECIFICATIONS.....	12-1
Replace Air Cleaner Inner Element (Optional).....	7-61	Std. Specification.....	12-1
G. Cooling System.....	7-63	Working Ranges.....	12-2
Check Coolant Level.....	7-64	Shoe Types and Applications.....	12-3
Check and Adjust Fan Belt Tension.....	7-65	Bucket Types and Applications.....	12-4
Change Coolant.....	7-68	Std. Specification.....	12-5
Clean Radiator/Oil Cooler Core.....	7-70	Working Ranges.....	12-6
Clean Air Conditioner Condenser.....	7-71		
Clean Air Conditioner Condenser Front Screen.....	7-71		
Clean Fuel Cooler (ZX50U-5N, 60USB-5N).....	7-71		
H. Electrical System.....	7-72		
Batteries.....	7-72		
Check Electrolyte Specific Gravity.....	7-75		

CONTENTS

Shoe Types and Applications	12-7
Bucket Types and Applications	12-8
Std. Specification	12-9
Working Ranges.....	12-10
Shoe Types and Applications	12-11
Bucket Types and Applications	12-12
OPTIONAL ATTACHMENT	13-1
Hydraulic Breaker, Hydraulic Crusher and Quick Coupler	13-1
Piping for Breaker and Crusher (Optional)	13-2
Precautions for Breaker Operation.....	13-3
Control Lever (SAE-backhoe Pattern).....	13-7
Additional Counterweight	13-8
Fuel Feed Device (Optional) (ZX50U-5N, 60USB-5N).....	13-9
Cab Tilting Mechanism	13-10
Maintenance.....	13-15
Check Tilt Mechanism Fulcrum Bolts and Working Screw Lock Nut	13-15
Greasing	13-16
INDEX	14-1

MACHINE NUMBERS

The manufacturing Nos. explained in this group is the individual number (serial No.) given to each machine and hydraulic components. These numbers are requested when inquiring any information on the machine and/or components. Fill these serial Nos. in the blank spaces in this group to immediately make them available upon request.

Machine

MODEL / TYPE: _____

PRODUCT IDENTIFICATION NUMBER:

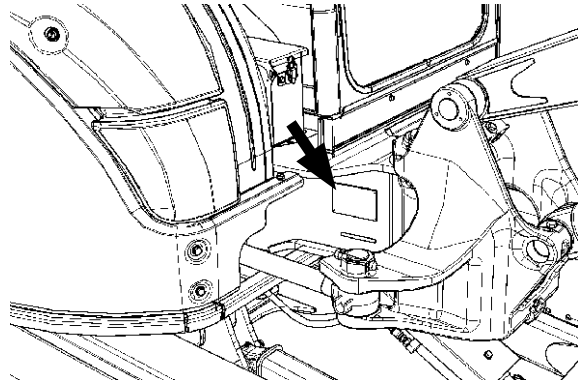

MADB-00-002

Product Identification Number

PRODUCT IDENTIFICATION NUMBER:

 NOTE:

HCMADG00X00270001 Marks to indicate the start and end of the PIN

PRODUCT IDENTIFICATION NUMBER (PIN)

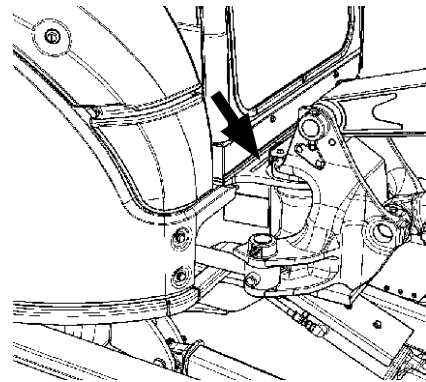

ZX35U-5N

MADB-00-003

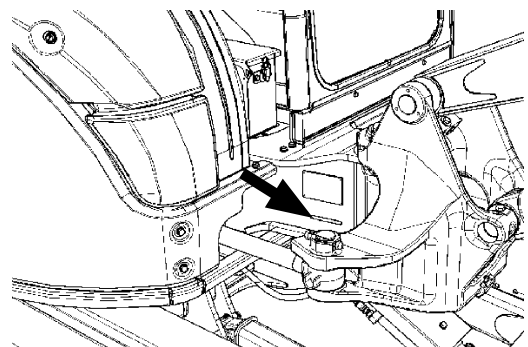

ZX50U-5N, 60USB-5N

MADB-00-002

MACHINE NUMBERS

Engine

TYPE: _____

MFG. NO.: _____

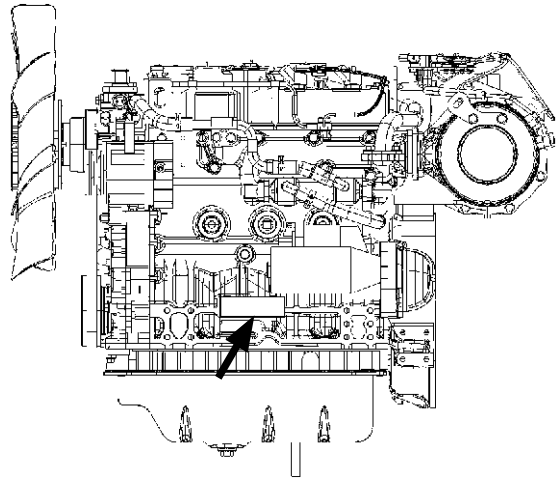

MADG-00-022

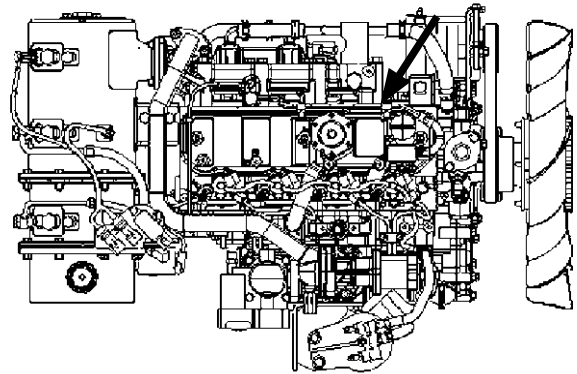

MADG-00-001

MACHINE NUMBERS

Muffler Filter

TYPE: _____

MFG. NO.: _____

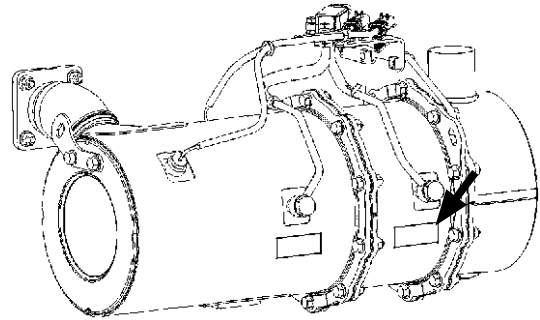

MADG-00-017

DOC (Diesel Oxidation Catalyst)

TYPE: _____

MFG. NO.: _____

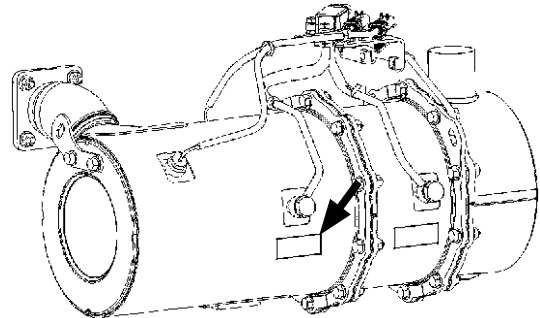

MADG-00-017

Travel Motor

TYPE: _____

MFG. NO.: _____

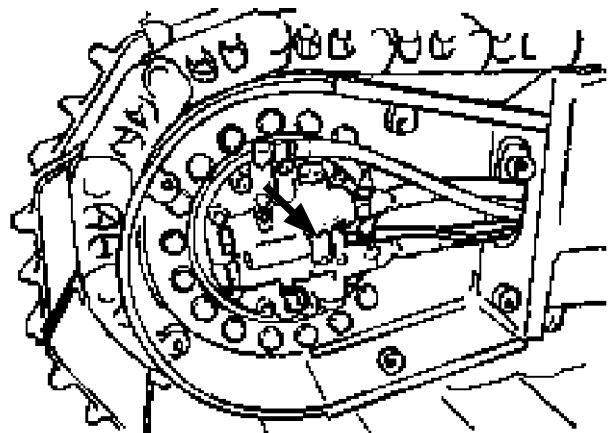

M1M0-00-004

MACHINE NUMBERS

Swing Motor

TYPE: _____

MFG. NO.: _____

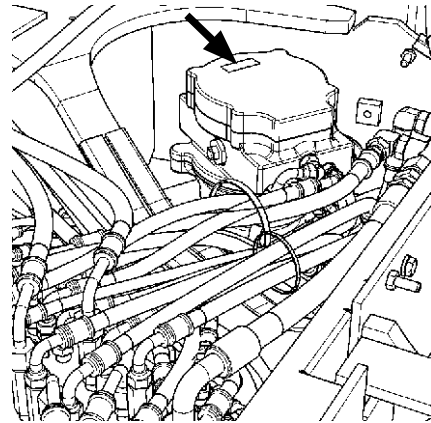

ZX35U-5N, 50U-5N

MADB-00-005

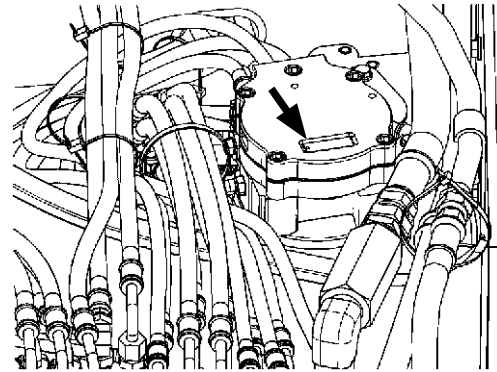

ZX60USB-5N

MADC-00-001

MACHINE NUMBERS

Hydraulic Pump

TYPE: _____

MFG. NO.: _____

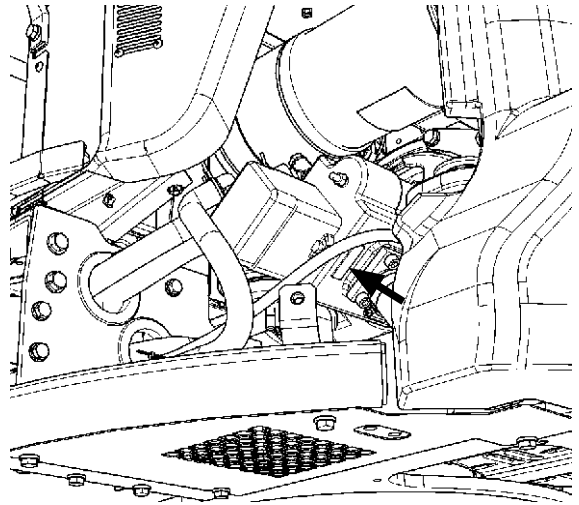

ZX35U-5N

MADB-00-006

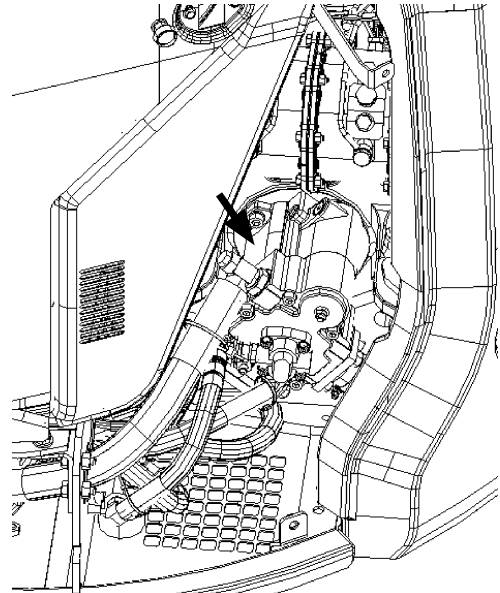

ZX50U-5N

MADB-00-021

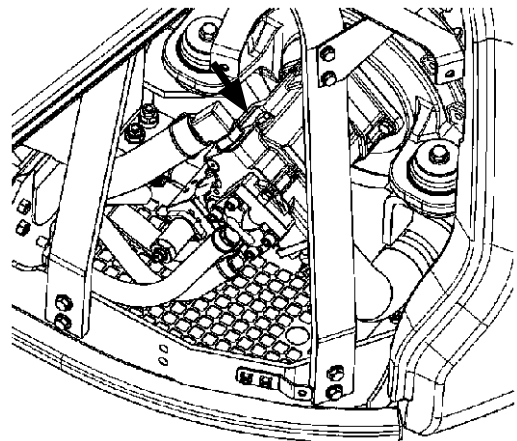

ZX60USB-5N

MADC-00-002

SAFETY

Recognize Safety Information

- These are the **SAFETY ALERT SYMBOLS**.
 - When you see these symbols on your machine or in this manual, be alert to the potential for personal injury.
 - Follow recommended precautions and safe operating practices.

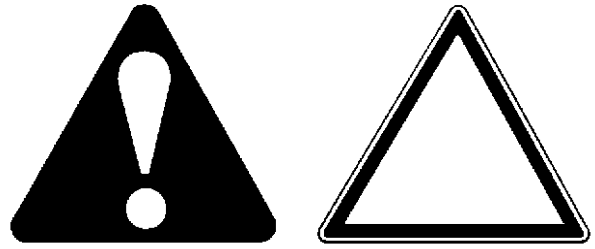

SA-688

Understand Signal Words

- On machine safety signs, signal words designating the degree or level of hazard - **DANGER**, **WARNING**, or **CAUTION** - are used with the safety alert symbol.
 - **DANGER** indicates an imminently hazardous situation which, if not avoided, will result in death or serious injury.
 - **WARNING** indicates a potentially hazardous situation which, if not avoided, could result in death or serious injury.
 - **CAUTION** indicates a potentially hazardous situation which, if not avoided, may result in minor or moderate injury.
 - **DANGER** or **WARNING** safety signs are located near specific hazards. General precautions are listed on **CAUTION** safety signs.
 - Some safety signs do not use any of the designated signal words above after the safety alert symbol are occasionally used on this machine.
- To avoid confusing machine protection with personal safety messages, a signal word **IMPORTANT** indicates a situation which, if not avoided, could result in damage to the machine.
-  **NOTE** indicates an additional explanation for an element of information.



SA-1223

SAFETY

Follow Safety Instructions

- Carefully read and follow all safety signs on the machine as well as all safety messages in this manual.
- Safety signs must be installed, maintained and replaced if damaged.
 - If a safety sign or this manual is damaged or missing, order a replacement from your authorized dealer in the same way you order other replacement parts (be sure to state machine model and serial number when ordering).
- Allow only properly trained, qualified, authorized personnel to operate the machine.
- Learn how to correctly operate and service the machine.
- Keep your machine in proper working condition.
 - Unauthorized modifications of the machine may impair its function and/or safety and affect machine life.
 - Do not modify any machine parts without authorization. Failure to do so may deteriorate the part safety, function, and/or service life. In addition, personal accident, machine trouble, and/or damage to material caused by unauthorized modifications will void Hitachi Warranty Policy.
 - Never modify the air inlet and exhaust parts and/or disassemble the muffler filter on the machines equipped with the muffler filter. Avoid giving shocks on the muffler filter by striking elements with other objects or dropping the elements. Failure to do so may affect the exhaust gas purifying device, possibly damaging it or lowering its performance.
 - Do not use attachments and/or optional parts or equipment not authorized by Hitachi. Failure to do so may deteriorate the safety, function, and/or service life of the machine. In addition, personal accident, machine trouble, and/or damage to material caused by using unauthorized attachments and/or optional parts or equipment will void Hitachi Warranty Policy.
- The safety messages in this SAFETY chapter are intended to illustrate basic safety procedures of machines. However it is impossible for these safety messages to cover every possible hazardous situation you may encounter. If you have any questions concerning safety, you should first consult your supervisor and/or your authorized dealer before operating or performing maintenance work on the machine.

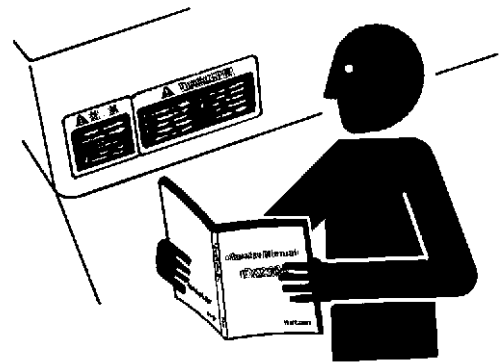

SA-003

SAFETY

Prepare For Emergencies

- Be prepared if a fire starts or if an accident occurs.
 - Keep a first aid kit and fire extinguisher on hand.
 - Thoroughly read and understand the label attached on the fire extinguisher and use it properly.
 - To ensure that a fire extinguisher can be always used when necessary, check and service the fire extinguisher at the recommended intervals as specified in the fire-extinguisher manual.
 - Establish emergency procedure guidelines to cope with any fire or accidents which may occur.
 - Keep emergency numbers for doctors, ambulance service, hospitals, and fire department posted near your telephone.

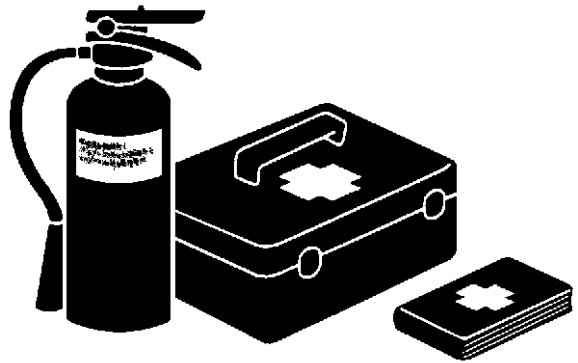

SA-437

Wear Protective Clothing

- Wear close fitting clothing and safety equipment appropriate to the job.

You may need:

- A hard hat
- Safety belt
- Safety shoes
- Safety glasses, goggles, or face shield
- Heavy gloves
- Hearing protection
- Reflective clothing
- Wet weather gear
- Respirator or filter mask

Be sure to wear the correct equipment and clothing for the job. Do not take any chances.

- Avoid wearing loose clothing, jewelry, or other items that can catch on control levers or other parts of the machine.
- Operating equipment safely requires the full attention of the operator. Do not wear radio or music headphones while operating the machine.

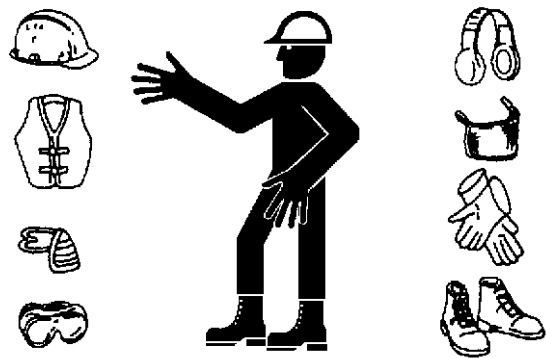

SA-438

SAFETY

Protect Against Noise

- Prolonged exposure to loud noise can cause impairment or loss of hearing.
- Wear a suitable hearing protective device such as earmuffs or earplugs to protect against objectionable or uncomfortably loud noises.



SA-434

Inspect Machine

- If any abnormality is found, be sure to repair it immediately before operating the machine.
- In the walk-around inspection, be sure to cover all points described in the “Daily Inspection” section in the operator’s manual.



SA-435

SAFETY

General Precautions for Cab

- Always keep inside the cab clean by observing instructions below, to prevent any personal accidents from occurring.
 - Before entering the cab, thoroughly remove all dirt and/or oil such as mud, grease, soil or stones that may mess up the cab from the soles of your work boots. If any controls such as a pedal is operated while with dirt and/or oil on the soles of the operator's work boots, the operator's foot may slip off the pedal, possibly resulting in a personal accident.
 - Do not mess up around the operator's seat with parts, tools, soil, stones, obstacles that may fold up or turn over, cans or lunch box. The levers or pedals become inoperable if obstacle jams in operation stroke of the travel levers/pedals, pilot control shut-off lever or control levers, which may result in serious injury or death.
 - Avoid storing transparent bottles in the cab. Do not attach any transparent type window decorations on the windowpanes as they may focus sunlight, possibly starting a fire.
 - Refrain from listening to the radio, or using music headphones or mobile telephones in the cab while operating the machine.
 - Keep all flammable objects and/or explosives away from the machine.
 - After using the ashtray, always cover it to extinguish the match and/or tobacco.
 - Do not leave cigarette lighters in the cab. If the temperature in the cab increases, the lighter may explode.
 - Use proper floor mat dedicated to the machine. If another floor mat is used, it may be displaced and contact with the travel pedals during operation, resulting in serious injury or death.

SAFETY

Use Handrails and Steps

- Falling is one of the major causes of personal injury.
 - When you get on and off the machine, always use the crawler instead of the step for safety. Be sure you have adequate footing on the crawler when getting on or off the machine.
 - When you get on and off the machine, always face the machine.
 - Maintain a three-point contact with the steps and handrails.
 - Do not use any controls as handholds.
 - Never jump on or off the machine. Never mount or dismount a moving machine.
 - In case adhered slippery material such as oil, grease, or mud is present on steps, handrails, or platforms, thoroughly remove such material.
 - Never get on and off the machine with tools in your hands.

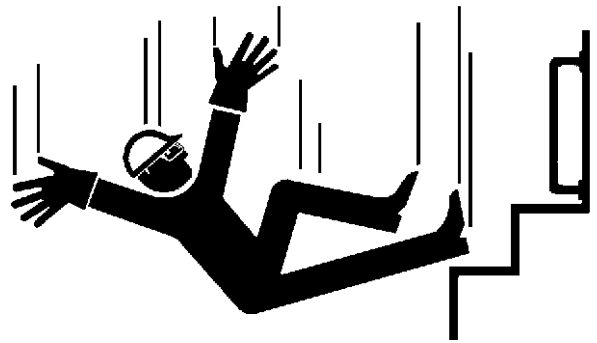

SA-439

Adjust the Operator's Seat

- A poorly adjusted seat for either the operator or the work at hand may quickly fatigue the operator leading to mis-operation of the machine.
 - The seat should be adjusted whenever the operator for the machine changes.
 - The operator should be able to fully depress the pedals and to correctly operate the control levers with his back firmly against the seat back.
 - If not, readjust the seat forward or backward, and check again.



SA-378

SAFETY

Ensure Safety Before Rising From or Leaving Operator's Seat

- Before rising from the operator's seat to open/close cab front window or to adjust the seat position, be sure to first lower the front attachment to the ground and then move the pilot control shut-off lever to the LOCK position. Failure to do so may allow the machine to unexpectedly move when a body part unintentionally comes in contact with a control lever, possibly resulting in serious personal injury or death.
- Before leaving the machine, be sure to first lower the front attachment to the ground and then move the pilot control shut-off lever to the LOCK position. Turn the key switch OFF to stop the engine.
- Before leaving the machine, close all windows, doors, and access covers and lock them up.

Fasten Your Seat Belt

- If the machine should overturn, the operator may become injured and/or thrown from the cab. Additionally the operator may be crushed by the overturning machine, resulting in serious injury or death.
 - Be sure to remain seated with the seat belt securely fastened whenever operating the machine.
 - Prior to operating the machine, thoroughly examine webbing, buckle and attaching hardware. If any item is damaged or worn, replace the seat belt or component before operating the machine. Replace the seat belt at least once every 3 years regardless of appearance.

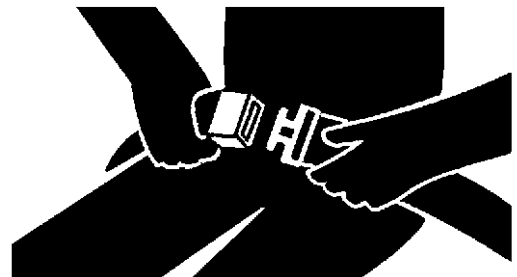

SA-237

SAFETY

Move and Operate Machine Safely

- Always be aware that there is a potential danger around the machine while operating the machine.
- Take extra care not to run over bystanders. Confirm the location of bystanders before moving, swinging, or operating the machine.
- Always keep the travel alarm and horn in working condition (if equipped).
- Before starting to move or operate the machine, sound the travel alarm and horn to alert bystanders.
- Use a signal person when moving, swinging, or operating the machine in congested areas. Locate the signal person so that the operator can always witness the signal person.
- Coordinate the meanings of all safety signs, hand signals and marks before starting the machine. Appoint a person who is responsible to make a signal and/or guidance.
- Never allow any persons or obstacles to enter the machine operation areas.
- Use appropriate illumination.

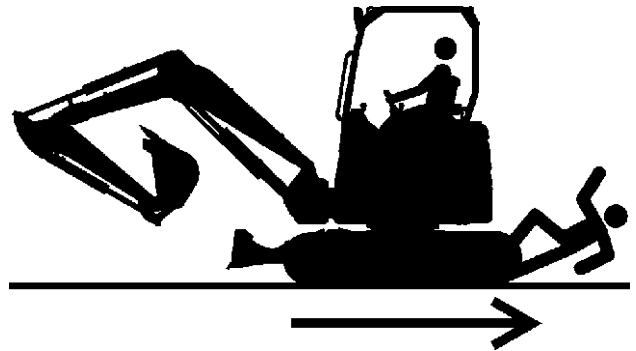

SA-1291

Operate Only From Operator's Seat

- Inappropriate engine starting procedures may cause the machine to runaway, possibly resulting in serious injury or death.
- Start the engine only when seated in the operator's seat.
- NEVER start the engine while standing on the tracks or on ground.
- Do not start engine by shorting across starter terminals. A hazardous situation may be created and/or possible damage to the machine may result.
- Before starting the engine, confirm that all control levers are in neutral.



SA-444

Jump Starting

- Failure to follow correct jump starting procedures could result in a battery explosion or a runaway machine.
- If the engine must be jump started, be sure to follow the instructions shown in the "OPERATING ENGINE" chapter.
- The operator must be seated in the operator's seat so that the machine will be under control when the engine starts. Jump starting is a two-person operation.
- Never use a frozen battery.

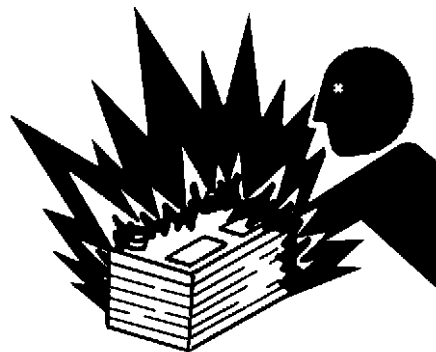

SA-032

SAFETY

Keep Riders Off Machine

- Riders on machine are subject to injury such as being struck by foreign objects and being thrown off the machine.
- Riders also obstruct the operator's view, resulting in the machine being operated in an unsafe manner.
- Only the operator is allowed on the machine. Keep riders off.

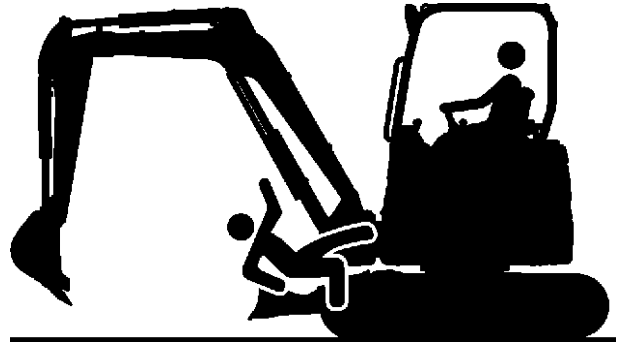

SA-1292

Precautions for Operations

- Investigate the work site before starting operations.
 - Be sure to wear close fitting clothing and required safety items, such as a hard hat, when operating the machine.
 - Keep all bystanders and unnecessary objects out of and away from the machine working areas. Always beware of the surroundings while operating the machine. Take care not to allow the rear part of the upperstructure to come in contact with objects when swinging the machine in a small area.
- When loading a dump truck, bring the bucket from the rear side of the dump truck to avoid moving the bucket over the dump truck cab or over any co-workers.

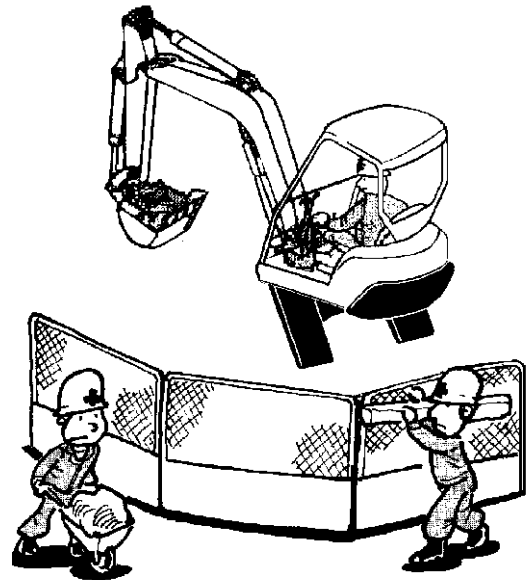

M586-12-012



Suggest:

For more complete manuals. Please go to the home page.

<https://www.ebooklibonline.com>

If the above button click is invalid. Please download this document first, and then click the above link to download the complete manual.

Thank you so much for reading

SAFETY

Investigate Job Site Beforehand

- When working at the edge of an excavation or on a road shoulder, the machine could tip over due to collapse of the ground, possibly resulting in serious injury or death.
 - Investigate the configuration and ground conditions of the job site beforehand to prevent the machine from falling and to prevent the ground, stockpiles, or banks from collapsing.
 - Make a work plan. Use machines appropriate to the work and job site.
 - Reinforce ground, edges, and road shoulders as necessary. Keep the machine well back from the edges of excavations and road shoulders.
 - When working on an incline or on a road shoulder, employ a signal person as required.
 - Never allow bystanders to enter the working area such as swing radius or traveling range.
 - When the footing is weak, reinforce the ground before starting work.
 - When working on frozen ground, be extremely alert. As ambient temperatures rise, footing may become loose and slippery.
 - When operating the machine near open flame, sparks, and/or dead grass, a fire may easily break out. Use special care not to cause a fire.
- Make sure the work site ground has sufficient strength to firmly support the machine. When working close to an excavation or on road shoulders, operate the machine with the tracks positioned perpendicular to the cliff face with travel motors at the rear and with the blade at the front, so that the machine can more easily evacuate if the cliff face collapses.
- If working at the bottom of a cliff or on a high bank is required, be sure to investigate the area first and confirm that no danger of the cliff or bank collapsing exists. If any possibility of cliff or bank collapsing exists, do not work in that area.
- Soft ground may collapse when operating the machine on it, possibly causing the machine to tip over. When working on a soft ground is required, be sure to reinforce the ground first using large pieces of steel plates strong enough and firm to easily support the machine.
- Note that there is always a possibility of machine tipping over when working on rough terrain or on slopes. Prevent machine tipping over from occurring. Operate the machine slowly to ensure safe operation.

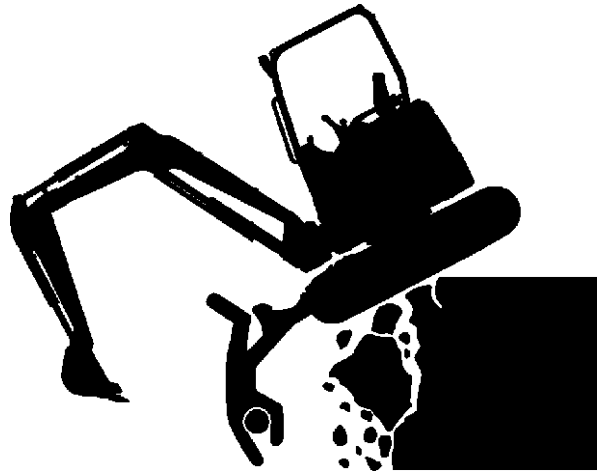

SA-1293

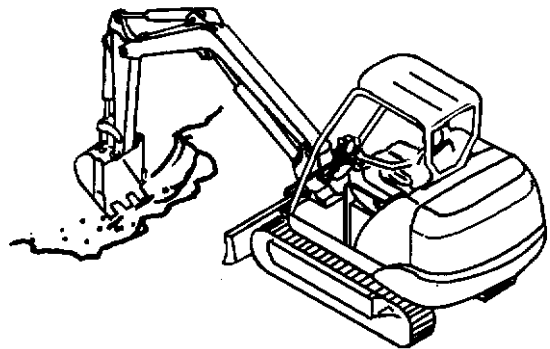

M586-05-021

SAFETY

Equipment of OPG

- In case the machine is operated in areas where the possibility of falling stones or debris exists, equip genuine Hitachi OPG guard. Contact your nearest Hitachi dealer for installation method of the OPG guard. Depending on the specifications applied to your machine, modification of the machine to meet ROPS standards will be possible.
- To maintain unimpaired operator protection and manufacturer's protective structure.
 - Damaged ROPS, OPG guard must be replaced, not repaired or revised.
 - Any alternation to the ROPS or OPG guard must be approved by the manufacturer.

ROPS : Roll Over Protective Structure

OPG : Operator Protective Guard

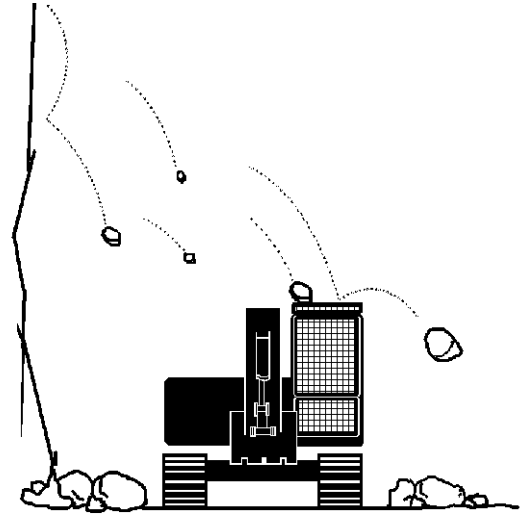

SA-490

Provide Signals for Jobs Involving Multiple Machines

- In case more than one machine is operated in the same job site, accidental collision between machines may cause serious injury or death.
- For jobs involving multiple machines, provide signals commonly known by all personnel involved. Also, appoint a signal person to coordinate the job site. Make sure that all personnel obey the signal person's directions.



SA-481

Confirm Direction of Machine to be Driven

- Incorrect travel pedal/lever operation may result in serious injury or death.
 - Before driving the machine, confirm the position of the undercarriage in relation to the operator's position.
 - If the travel motors are located towards the front of the cab, the machine will move in the reverse direction when travel pedals/levers are operated.

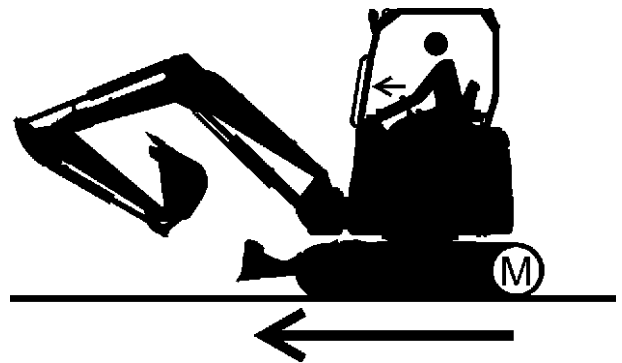

SA-1294

<https://www.ebooklibonline.com>

Hello dear friend!

Thank you very much for reading.

Enter the link into your browser.

The full manual is available for immediate download.

<https://www.ebooklibonline.com>