

Operator's Manual

ZAXIS

30U-2

35U-2

40U-2

50U-2

Hydraulic Excavator

Serial No.
ZAXIS30U-2 010001 and up
ZAXIS35U-2 010001 and up
ZAXIS40U-2 010001 and up
ZAXIS50U-2 010001 and up

HITACHI

INDEX

MACHINE NUMBERS

SAFETY

SAFETY SIGNS

COMPONENTS NAME

OPERATOR'S STATION

BREAK-IN

OPERATING ENGINE

DRIVING THE MACHINE

OPERATION

TRANSPORTING

MAINTENANCE

CONSUMABLE PARTS LIST

MAINTENANCE UNDER SPECIAL ENVIRONMENTAL CONDITIONS

STORAGE

TROUBLESHOOTING

SPECIFICATIONS

REFERENCE

INDEX

CONTENTS

MACHINE NUMBERS

SAFETY

Recognize Safety Information	S-1
Understand Signal Words	S-1
Follow Safety Instructions	S-2
Prepare for Emergencies	S-2
Wear Protective Clothing	S-3
Protect Against Noise	S-3
Inspect Machine Daily	S-3
Tidy Up Inside Cab	S-4
Use Handholds and Steps	S-4
Adjust the Operator's Seat	S-5
Fasten Your Seat Belt	S-5
Move and Operate Machine Safely	S-6
Operate Only from Operator's Seat	S-7
Jump Starting	S-7
Keep Riders Off Machine	S-7
Investigate Job Site Beforehand	S-8
Provide Signals for Jobs Involving Multiple Numbers of Machines	S-9
Confirm Direction of Machine to be Driven	S-9
Drive Machine Safely	S-10
Avoid Injury from Rollaway Accidents	S-11
Avoid Injury from Back-Over and Swing Accidents	S-12
Keep Person Clear from Working Area	S-13
Never Position Bucket Over Anyone	S-13
Avoid Undercutting	S-13
Avoid Tipping	S-14
Never Undercut a High Bank	S-14
Dig with Caution	S-15
Operate with Caution	S-15
Avoid Power Lines	S-15
Do Not Use for Craning Operations	S-16
Protect Against Flying Debris	S-16
Park Machine Safely	S-17
Handle Fluids Safely – Avoid Fires	S-17
Safety Transporting	S-18
Practice Safe Maintenance	S-19
Warn Others of Service Work	S-20
Support Machine Properly	S-20
Stay Clear of Moving Parts	S-20
Prevent Parts from Flying	S-21
Store Attachments Safely	S-21
Prevent Burns	S-22
Replace Rubber Hoses Periodically	S-23
Avoid High-Pressure Fluids	S-23
Prevent Fires	S-24
Evacuating in Case of Fire	S-26
Beware of Exhaust Fumes	S-26
Precautions for Welding and Grinding	S-27
Avoid Heating Near Pressurized Fluid Lines	S-27

Avoid Applying Heat to Lines Containing Flammable Fluids	S-27
Remove Paint before Welding or Heating	S-28
Prevent Battery Explosions	S-28
Precautions for Handling Refrigerant	S-29
Handle Chemical Products Safely	S-29
Dispose of Waste Properly	S-30

SAFETY SIGNS	S-31
---------------------------	------

COMPONENTS NAME	1-1
------------------------------	-----

OPERATOR'S STATION

Pedals and Levers	1-2
Monitor Panel and Switch Panel	1-3
Key Switch	1-4
Switch Panel	1-4
Monitor Panel	1-5
Coolant Temperature Gauge	1-5
Fuel Gauge	1-5
System Failure Indicator	1-6
Engine Oil Pressure Indicator	1-6
Overheat Indicator	1-6
Fuel Level Indicator	1-6
Alternator Indicator	1-7
Preheat Indicator	1-7
Fast Travel Mode Indicator	1-7
Liquid Crystal display (LCD), Display Selection Switch, and Set Switch	1-8
How to Operate Trip Meter	1-10
Air Conditioner Operation	1-13
Tips for Air Conditioner Usage	1-15
Radio (Cab Equipped Machines)	1-16
AM/FM Radio Operation	1-17
Cab Door Release lever (Only on cab-equipped machines)	1-19
Opening/Closing Cab Front Window (Only on cab-equipped machines)	1-20
Adjusting Operator's Seat	1-21
Tool and Operator's manual Boxes	1-21
Opening/Closing Cab Rear Window (Cab-equipped machines)	1-22
Emergency Exit (Cab-equipped machines)	1-23
Seat Belt (Optional)	1-24
Cab Light (Cab-equipped machines)	1-24

BREAK-IN

Breaking in New Machine	2-1
-------------------------------	-----

OPERATING ENGINE

Engine Prestart Engine	3-1
Starting Engine	3-2
Starting in Cold Weather	3-3
Check Machine After Starting Engine	3-4
Using Booster Batteries	3-5
Stopping the Engine	3-6

<https://www.ebooklibonline.com>

Hello dear friend!

Thank you very much for reading.

Enter the link into your browser.

The full manual is available for immediate download.

<https://www.ebooklibonline.com>

CONTENTS

DRIVING THE MACHINE

Travel Levers and Pedals	4-1
Travel Mode Switch	4-3
Precautions for Traveling.....	4-4
Traveling on Soft Ground.....	4-5
Raise One Track Using Boom and Arm	4-5
Towing Machine.....	4-6
Driving In Water or on Soft Ground	4-7
Precautions for Traveling on Slopes.....	4-8
Parking and Stopping on Slope	4-9
Parking on Slopes.....	4-9

OPERATION

Control Lever (ISO Excavator Pattern).....	5-1
Control Lever (H-Pattern: HITACHI Excavator Pattern).....	5-2
Control Lever (SAE-Backhoe Pattern) --- If Equipped (2 Way Multi Valve)	5-3
Boom-Swing Pedal	5-4
Auxiliary Pedal (Optional)	5-5
Blade Lever.....	5-6
Precautions for Blade Operation	5-7
Pilot Control Shut-Off Lever.....	5-8
Warming Up Operation.....	5-9
Warming Up in Cold Weather.....	5-9
Auto-Idle Control.....	5-10
Precautions for Operations	5-11
Operate Machine Safely	5-11
Operating Backhoe	5-12
Grading Operation	5-13
Avoid Driving Bucket Teeth Into Ground	5-13
Avoid Abusive Operation	5-13
Avoid Striking with Bucket	5-14
Avoid Excavation Using Upperstructure and/or Boom Swing Power.....	5-14
Use Correct Track Shoe	5-14
Avoid Other than Specified Machine Operations	5-15
Precautions for Using Bucket Hook.....	5-16
Boom Cylinder May Hit Blade.....	5-16
Avoid Hitting Blade with Bucket.....	5-17
Avoid Colliding Blade Against Rocks.....	5-17
Avoid Colliding Boom Cylinder with Track.....	5-17
Precautions for Installing Wide Bucket or Special Type Bucket.....	5-17
Using Rubber Crawler	5-18
Hydraulic Breaker (Optional)	5-20
Crusher Operation	5-23
Precautions for After Operating the Machine	5-24
Auxiliary Flow Rate Control (Optional)	5-25

TRANSPORTING

Transporting by Road	6-1
Trailer Loading/Unloading	6-1
Loading	6-2

Securing the Machine to the Frailer for Transportation.....	6-3
Unloading	6-4
Lifting Machine with Crane	6-5

MAINTENANCE

Procedures.....	7-1
Prepare Machine for Inspection/Maintenance	7-2
Opening/Closing Engine Access Covers	7-3
Opening/Closing Tank Covers	7-4
Daily Inspection.....	7-5
Periodic Replacement of Parts.....	7-6
Maintenance Guide	7-7
The Brand Names of Recommended Oils and Lubricants	7-10
A. Greasing.....	7-11
Front Joint Pins	7-11
Bucket and Link Pins.....	7-13
Blade Pins	7-13
Precautions for Front Attachment and Blade Removal	7-13
Swing Bearing	7-14
Swing Internal Gear	7-15
Control Lever Universal Joint.....	7-15
B. Engine	7-16
Engine Oil Level	7-16
Change Engine Oil.....	7-17
Replace Engine Oil Filter	7-17
C. Transmission.....	7-19
Travel Reduction Gear	7-19
D. Hydraulic System	7-21
Inspection and Maintenance of Hydraulic Equipment	7-21
Check Hydraulic Oil Level.....	7-22
Drain Hydraulic Oil Tank Sump.....	7-23
Change Hydraulic Oil	7-24
Clean Suction Filter.....	7-27
Replace Full Flow Filter	7-28
Replace Pilot Filter	7-29
Check Hoses and Lines	7-31
E. Fuel System	7-36
Check Water Separator	7-37
Drain Fuel Tank Sump	7-37
Replace Fuel Filter	7-38
Check Fuel Hoses.....	7-39
F. Air Cleaner	7-40
Clean the Air Cleaner Element	7-40
Replace the Air Cleaner Element.....	7-40
G. Cooling System	7-41
Check Coolant Level.....	7-42
Check and Adjust Fan Belt Tension.....	7-43
Change Coolant	7-44
Clean Radiator	7-45
H. Electrical System.....	7-46
Batteries	7-46
Replacing Fuses	7-49

CONTENTS

I. Miscellaneous	7-50
Check Bucket Teeth	7-50
Replace Bucket.....	7-52
Adjusting Track Sag (Rubber Crawler) and Check for Damage.....	7-53
Replace Rubber Track.....	7-55
Check Track Sag (Steel Crawler)	7-57
Check and Replace Seat Belt.....	7-60
Check Bucket Hook (Optional)	7-60
Check Air conditioner (Machine with Cab).....	7-61
Clean and Replace Air Conditioner Re-circulation Filter	7-62
Clean Re-circulation Filter	7-62
Replace Re-circulation Filter.....	7-62
Check Injection Nozzle	7-64
Check and Adjust Valve clearance	7-64
Check Injection Timing	7-64
Measure Engine Compression pressure	7-64
Check Starter and Alternator	7-65
Check Radiator Cap	7-65
Check Tightening Torque of Bolts and Nuts	7-66
Preparation for Inspection and Maintenance	7-69
Tilt Mechanism Operation	7-70

CONSUMABLE PARTS LIST

MAINTENANCE UNDER SPECIAL ENVIRONMENTAL CONDITIONS.....

STORAGE

Storing the Machine	10-1
Removing the Machine From Storage	10-2

TROUBLESHOOTING

SPECIFICATIONS

Specifications	12-1
Working Ranges	12-5
Shoe Types and Applications.....	12-9
Bucket Types and Applications.....	12-13

REFERENCE

Electronic (Immobilize) Key	13-1
Additional Counterweight	13-2

INDEX.....

14-1

MACHINE NUMBERS

The manufacturing Nos. explained in this group is the individual number (serial No.) given to each machine and hydraulic components. These numbers are requested when inquiring any information on the machine and/or components. Fill these serial Nos. in the blank spaces in this group to immediately make them available upon request.

MACHINE

MODEL/TYPE: _____

PRODUCT
IDENTIFICATION
NUMBER: _____

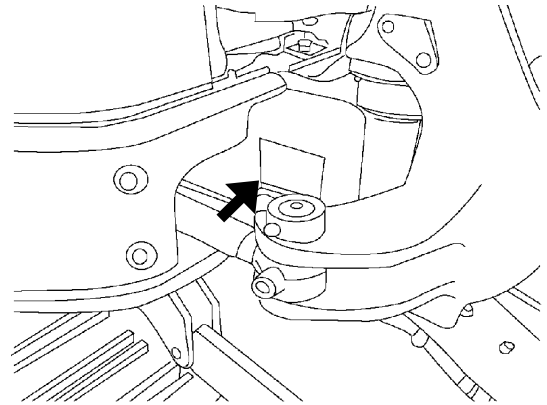

M1M7-00-001

PRODUCT IDENTIFICATION NUMBER

PRODUCT
IDENTIFICATION
NUMBER: _____

 NOTE:

HCM1M700X00010001 Marks to indicate the start and end of the PIN

PRODUCT IDENTIFICATION
NUMBER (PIN)

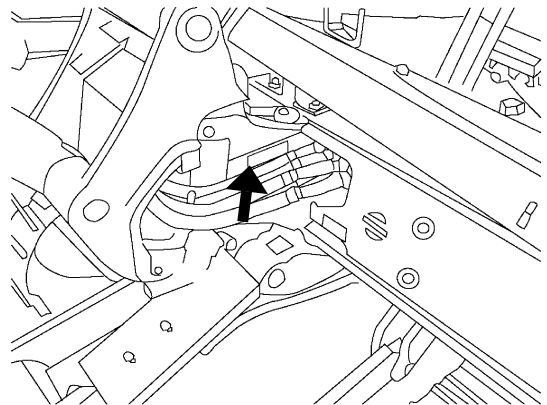

M1M7-00-002

MACHINE NUMBERS

MEMO

A series of horizontal dotted lines for writing.

SAFETY

RECOGNIZE SAFETY INFORMATION

- These are the **SAFETY ALERT SYMBOLS**.
 - When you see these symbols on your machine or in this manual, be alert to the potential for personal injury.
 - Follow recommended precautions and safe operating practices.



SA-688

UNDERSTAND SIGNAL WORDS

- On machine safety signs, signal words designating the degree or level of hazard - **DANGER**, **WARNING**, or **CAUTION** - are used with the safety alert symbol.
 - **DANGER** indicates an imminently hazardous situation which, if not avoided, will result in death or serious injury.
 - **WARNING** indicates a potentially hazardous situation which, if not avoided, could result in death or serious injury.
 - **CAUTION** indicates a potentially hazardous situation which, if not avoided, may result in minor or moderate injury.
 - **DANGER** or **WARNING** safety signs are located near specific hazards. General precautions are listed on **CAUTION** safety signs.
 - Some safety signs don't use any of the designated signal words above after the safety alert symbol are occasionally used on this machine.
- **CAUTION** also calls attention to safety messages in this manual.
- To avoid confusing machine protection with personal safety messages, a signal word **IMPORTANT** indicates a situation which, if not avoided, could result in damage to the machine.
-  **NOTE** indicates an additional explanation for an element of information.



IMPORTANT



SA-1223

SAFETY

FOLLOW SAFETY INSTRUCTIONS

- Carefully read and follow all safety signs on the machine as well as all safety messages in this manual.
- Safety signs must be installed, maintained and replaced if damaged.
 - If a safety sign or this manual is damaged or missing, order a replacement from your nearest Hitachi dealer in the same way you order other replacement parts (be sure to state machine model and serial number when ordering).
- Allow only properly trained, qualified, authorized personnel to operate the machine.
- Learn how to correctly operate and service the machine.
- Keep your machine in proper working condition.
- Always operate the machine within the specification.
 - Unauthorized modifications of the machine may impair the functions and/or safety and affect machine life and the warranty will become void.
- The safety messages in this SAFETY chapter are intended to illustrate basic safety procedures of machines. However it is impossible for these safety messages to cover every possible hazardous situation you may encounter. If you have any questions concerning safety, you should first consult your supervisor and/or your nearest Hitachi dealer before operating or performing maintenance work on the machine.

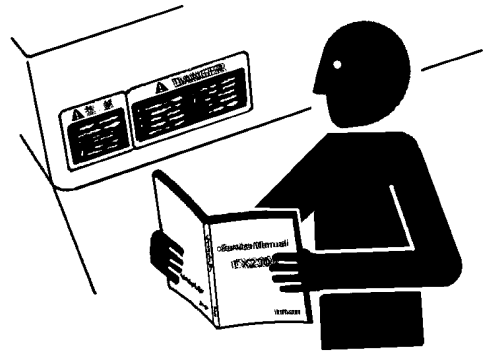

SA-003

PREPARE FOR EMERGENCIES

- Be prepared if a fire starts or if an accident occurs.
 - Keep a first aid kit and fire extinguisher on hand.
 - Thoroughly read and understand the label attached on the fire extinguisher and use it properly.
 - To ensure that a fire-extinguisher can be always used when necessary, check and service the fire-extinguisher at the recommended intervals as specified in the fire-extinguisher manual.
 - Establish emergency procedure guidelines to cope with any fire or accidents which may occur.
 - Keep emergency numbers for doctors, ambulance service, hospitals, and fire department posted near your telephone.



SA-437

SAFETY

WEAR PROTECTIVE CLOTHING

- Wear close fitting clothing and safety equipment appropriate to the job.

You may need:

- A hard hat
- Safety belt
- Safety shoes
- Safety glasses, goggles, or face shield
- Heavy gloves
- Hearing protection
- Reflective clothing
- Wet weather gear
- Respirator or filter mask.

Be sure to wear the correct equipment and clothing for the job. Do not take any chances.

- Avoid wearing loose clothing, jewelry, or other items that can catch on control levers or other parts of the machine.
- Operating equipment safely requires the full attention of the operator.
- Do not wear radio or music headphones while operating the machine.

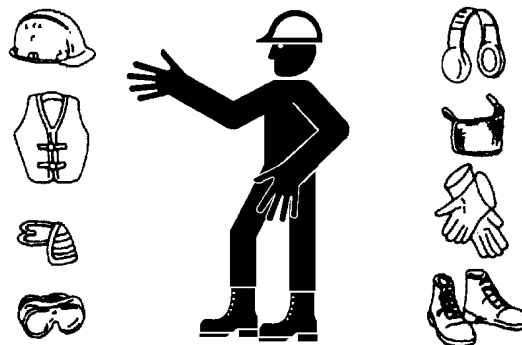

SA-438

PROTECT AGAINST NOISE

- Prolonged exposure to loud noise can cause impairment or loss of hearing.
- Wear a suitable hearing protective device such as earmuffs or earplugs to protect against objectionable or uncomfortably loud noises.



SA-434

INSPECT MACHINE DAILY

- If any abnormality is found, be sure to repair it immediately before operating the machine.
- In the walk-around inspection, be sure to cover all points described in the “PRE-START INSPECTION” chapter in the operator’s manual.



SA-435

SAFETY

TIDY UP INSIDE CAB

- Always keep inside the cab clean by observing instructions below, to prevent any personal accidents from occurring.
- Remove mud and/or oily material from the shoe soles before entering the cab. If pedals are operated without removing mud or oily matter, the foot may slip off the pedal, possibly creating a hazardous situation.
- Do not leave parts and/or tools around the operator's seat.
- Do not keep a transparent water bottle in the cab. The transparent water bottle may concentrate the sun light like a lens, possibly causing a fire.
- Do not wear radio or music headphones and do not use a cell phone while traveling or operating the machine.
- Never allow hazardous materials such as combustible and/or explosive material in the cab.
- Do not leave a lighter in the cab. If the temperature in the cab increases, the lighter may explode.

USE HANDHOLDS AND STEPS

- Falling is one of the major causes of personal injury.
 - When you get on and off the machine, always face the machine.
 - Maintain a three-point contact with the steps and handrails.
 - Do not use any controls as handholds.
 - Never jump on or off the machine. Never mount or dismount a moving machine.
 - In case adhered slippery material such as oil, grease, or mud is present on steps, handrails, or platforms, thoroughly remove such material.

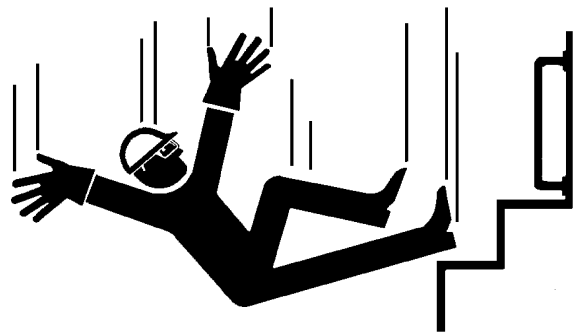

SA-439

SAFETY

ADJUST THE OPERATOR'S SEAT

- A poorly adjusted seat for either the operator or for the work at hand may quickly fatigue the operator leading to mis-operation of the machine.
- The seat should be adjusted whenever the operator for the machine changes.
- The operator should be able to fully depress the pedals and to correctly operate the control levers with his back firmly against the seat back.
- If not, readjust the seat forward or backward, and check again.



SA-378

FASTEN YOUR SEAT BELT

- If the machine should overturn, the operator may become injured and/or thrown from the cab. Additionally the operator may be crushed by the overturning machine, resulting in serious injury or death.
- Be sure to remain seated with the seat belt securely fastened whenever operating the machine.
- Prior to operating the machine, thoroughly examine webbing, buckle and attaching hardware. If any item is damaged or worn, replace the seat belt or component before operating the machine. Replace the seat belt at least once every 3 years regardless of appearance

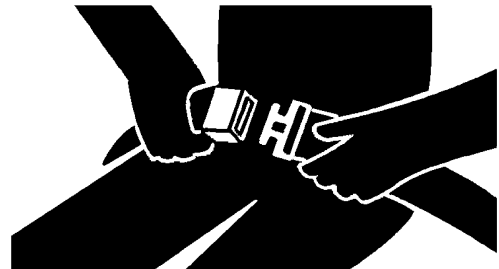

SA-237

SAFETY

MOVE AND OPERATE MACHINE SAFELY

- Always be aware that there is a potential danger around the machine while operating the machine.
- Take extra care not to run over bystanders. Confirm the location of bystanders before moving, swinging, or operating the machine.
- Always keep the travel alarm and horn in working condition (if equipped).
- Before starting to move or operate the machine, sound the travel alarm and horn to alert bystanders.
- Use a signal person when moving, swinging, or operating the machine in congested areas. Locate the signal person so that the operator can always witness the signal person.
- Coordinate the meanings of all safety signs, hand signals and marks before starting the machine. Appoint a person who is responsible to make a signal and/or guidance.
- Never allow any persons or obstacles to enter the machine operation areas.
- Use appropriate illuminations.

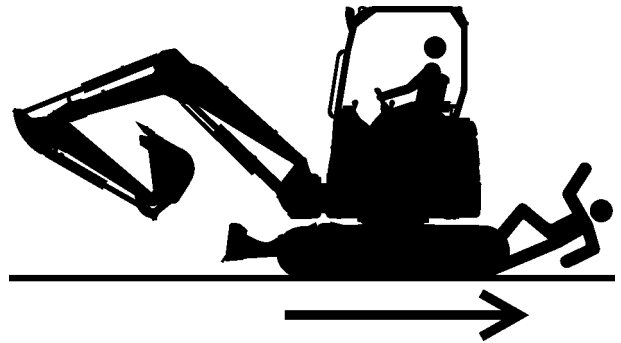

SA-1291

SAFETY

OPERATE ONLY FROM OPERATOR'S SEAT

- Inappropriate engine starting procedures may cause the machine to runaway, possibly resulting in serious injury or death.
- Start the engine only when seated in the operator's seat.
- NEVER start the engine while standing on the tracks or on ground.
- Do not start engine by shorting across starter terminals. A hazardous situation may be created and/or possible damage to the machine may result.
- Before starting the engine, confirm that all control levers are in neutral.



SA-444

JUMP STARTING

- Failure to follow correct jump starting procedures could result in a battery explosion or a runaway machine.
- If the engine must be jump started, be sure to follow the instructions shown in the "OPERATING THE ENGINE" chapter.
- The operator must be seated in the operator's seat so that the machine will be under control when the engine starts. Jump starting is a two-person operation.
- Never use a frozen battery.
- Failure to follow correct jump starting procedures could result in a battery explosion or a runaway machine.

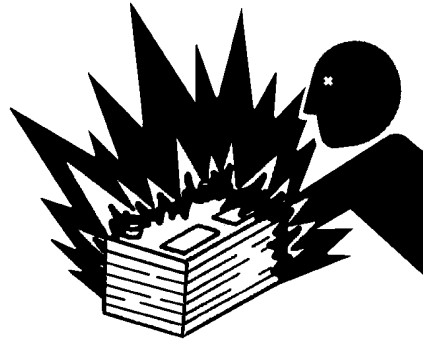

SA-032

KEEP RIDERS OFF MACHINE

- Riders on machine are subject to injury such as being struck by foreign objects and being thrown off the machine.
- Riders also obstruct the operator's view, resulting in the machine being operated in an unsafe manner.
- Only allow the operator is allowed on the machine. Keep riders off.



SA-1292

SAFETY

INVESTIGATE JOB SITE BEFOREHAND

- When working at the edge of an excavation or on a road shoulder, the machine could tip over due to collapse of the ground, possibly resulting in serious injury or death.
- Investigate the configuration and ground conditions of the job site beforehand to prevent the machine from falling and to prevent the ground, stockpiles, or banks from collapsing.
- Make a work plan. Use machines appropriate to the work and job site.
- Reinforce ground, edges, and road shoulders as necessary. Keep the machine well back from the edges of excavations and road shoulders.
- When working on an incline or on a road shoulder, employ a signal person as required.
- Never allow bystanders to enter the working area such as swing radius or traveling range.
- Confirm that your machine is equipped a FOPS cab before working in areas where the possibility of falling stones or debris exist.
- When the footing is weak, reinforce the ground before starting work.
- When working on frozen ground, be extremely alert. As ambient temperatures rise, footing may become loose and slippery.
- When operating the machine near open flame, sparks, and/or dead grass, a fire may easily break out. Use special care not to cause a fire.

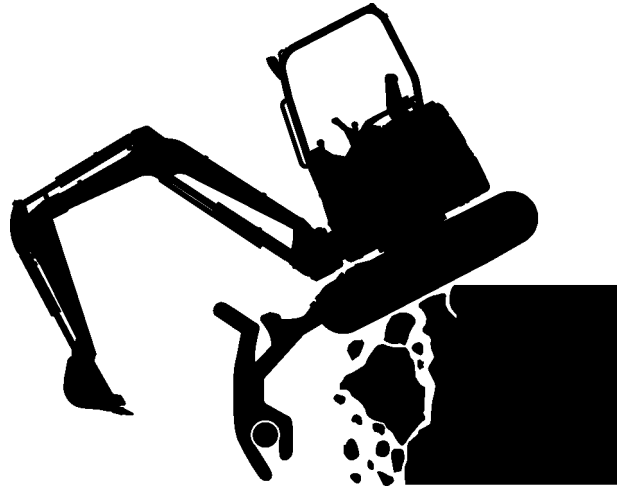

SA-1293

SAFETY

PROVIDE SIGNALS FOR JOBS INVOLVING MULTIPLE NUMBERS OF MACHINES

- In case more than one machine is operated in the same job site, accidental collision between machines may cause serious injury or death.
- For jobs involving multiple numbers of machines, provide signals commonly known by all personnel involved. Also, appoint a signal person to coordinate the job site. Make sure that all personnel obey the signal person's directions.



SA-481

CONFIRM DIRECTION OF MACHINE TO BE DRIVEN

- Incorrect travel pedal/lever operation may result in serious injury death.
 - Before driving the machine, confirm the position of the undercarriage in relation to the operator's position.
 - If the travel motors are located towards the front of the cab, the machine will move in the reverse direction when travel pedals/levers are operated.

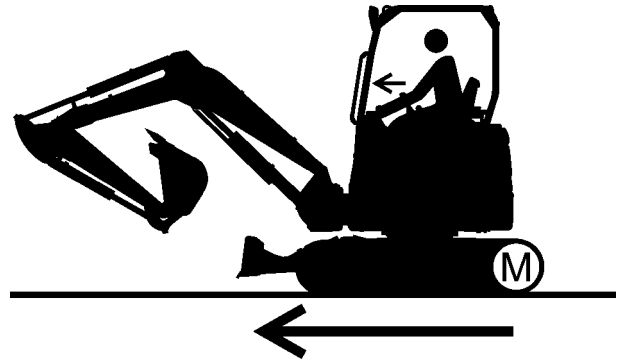

SA-1294

SAFETY

DRIVE MACHINE SAFELY

- Driving the machine in the incorrect direction may result in serious injury or death and/or severe damage to property.
- Before moving the machine, confirm which way to move travel pedals/levers for the corresponding direction you wish to travel.
 - Avoid passing over any obstructions. Failure to do so may cause soil, rock fragments and/or metal pieces to be scattered around the machine. Keep bystanders away from the machine.
- Traveling on a grade may cause the machine to slip or to overturn, possibly resulting in serious injury or death.
 - When traveling up or down a grade, keep the bucket in the direction of travel, approximately 200 to 300 mm (8 to 12 in) (A) above the ground so that lowering the bucket onto the ground can quickly stop the machine.
 - If machine starts to skid or becomes unstable, lower the bucket immediately.
- Traveling across the face of slope or steering on a slope may cause the machine to skid or to turnover. If the direction must be changed on a slope, first move the machine to level ground, then, change the traveling direction to ensure safe operation.

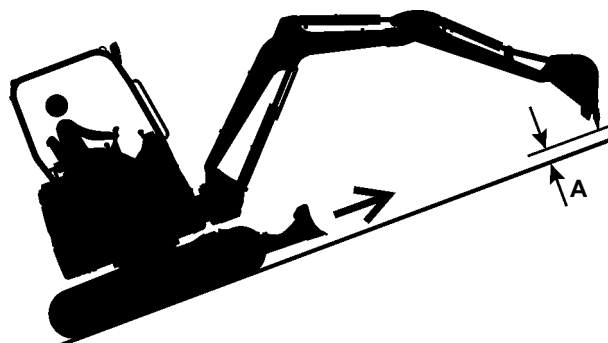

SA-1295

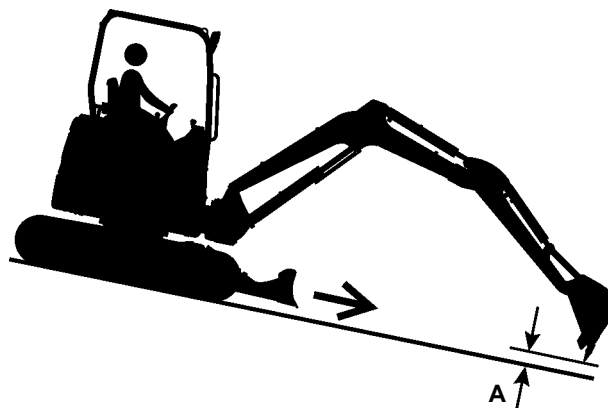

SA-1296

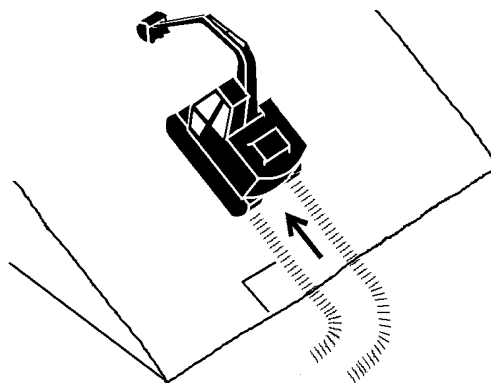

SA-441

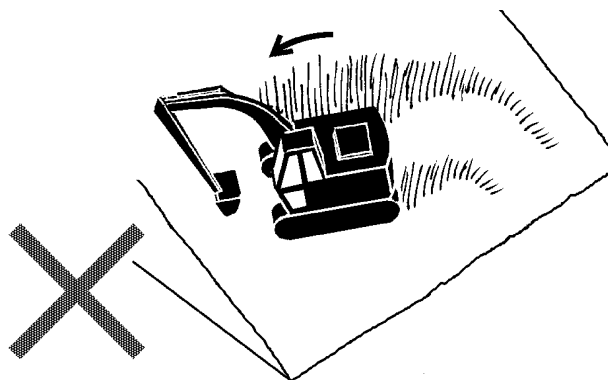

SA-442

SAFETY

AVOID INJURY FROM ROLLAWAY ACCIDENTS

- Death or serious injury may result if you attempt to mount or try to bodily stop a moving machine.
- Park the machine in compliance with the safe parking procedures described on page S-15 to prevent the machine from running away.
 - Block both tracks and lower the bucket to the ground, thrust the bucket teeth into the ground if you must park on a grade.
 - Park a reasonable distance from other machines.

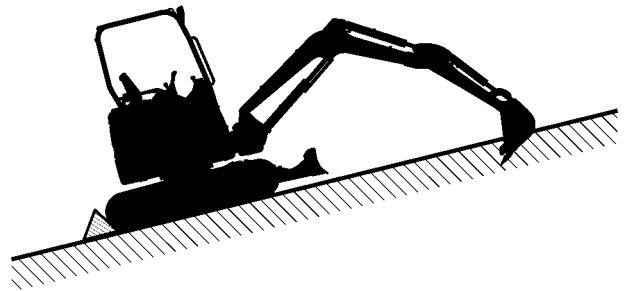

SA-1297



Suggest:

For more complete manuals. Please go to the home page.

<https://www.ebooklibonline.com>

If the above button click is invalid. Please download this document first, and then click the above link to download the complete manual.

Thank you so much for reading

SAFETY

AVOID INJURY FROM BACK-OVER AND SWING ACCIDENTS

- If any person is present near the machine when backing or swinging the upperstructure, the machine may hit or run over that person, resulting in serious injury or death.

To avoid back-over and swing accidents:

- Always look around **BEFORE YOU BACK UP AND SWING THE MACHINE**. BE SURE THAT ALL BYSTANDERS ARE CLEAR.
- Keep the travel alarm in working condition (if equipped). ALWAYS BE ALERT FOR BYSTANDERS MOVING INTO THE WORK AREA. USE THE HORN OR OTHER SIGNAL TO WARN BYSTANDERS BEFORE MOVING MACHINE.
- USE A SIGNAL PERSON WHEN BACKING UP IF YOUR VIEW IS OBSTRUCTED. ALWAYS KEEP THE SIGNAL PERSON IN VIEW. Use hand signals, which conform to your local regulations, when work conditions require a signal person.
- No machine motions shall be made unless signals are clearly understood by both signalman and operator.
- Learn the meanings of all flags, signs, and markings used on the job and confirm who has the responsibility for signaling.
- Keep windows, mirrors, and lights clean and in good condition.
- Dust, heavy rain, fog, etc., can reduce visibility. As visibility decreases, reduce speed and use proper lighting.
- Read and understand all operating instructions in the operator's manual.

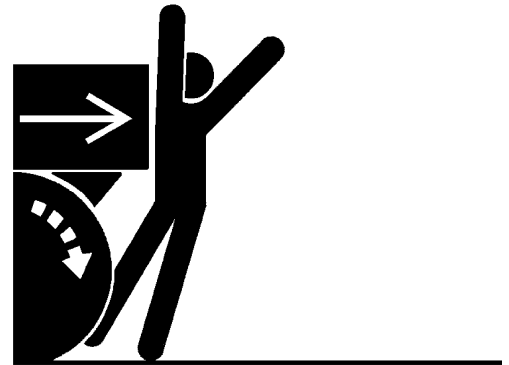

SA-383

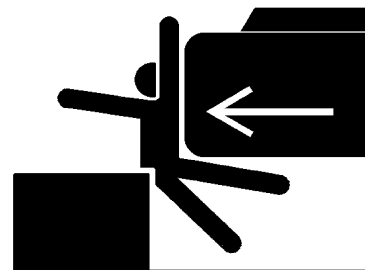

SA-384

021-E01A-0494-8

SAFETY

KEEP PERSONNEL CLEAR FROM WORKING AREA

- If a person is present near the operating machine, the person may come in contact with the swinging front attachment or counterweight and/or may be crushed against an other object, resulting in serious injury or death.
- Before operating the machine, set up barriers to the sides and rear area of the bucket swing radius to prevent anyone from entering the work area.
- Make sure that no personnel other than the signal person or no obstacles are present in the working area before operating the machine.

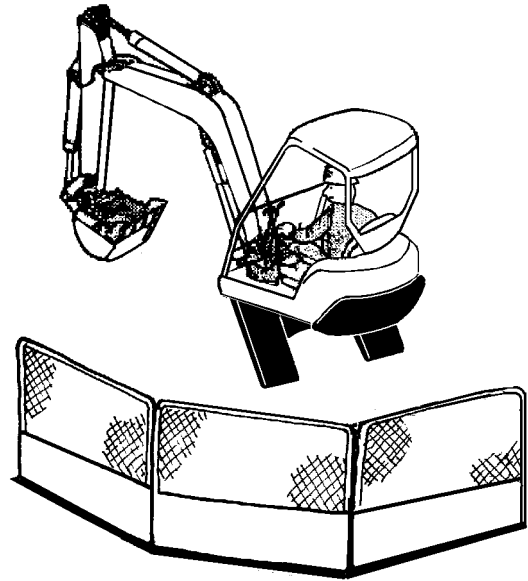

SA-667

NEVER POSITION BUCKET OVER ANYONE

- Never lift, move, or swing bucket above anyone or a truck cab. Serious injury or machine damage may result due to bucket load spill or due to collision with the bucket.
- Never allow the bucket to pass over anyone to avoid personal injury or death.



SA-668

AVOID UNDERCUTTING

- In order to retreat from the edge of an excavation if the footing should collapse, always position the undercarriage perpendicular to the edge of the excavation with the travel motors at the rear.
- If the footing starts to collapse and if retreat is not possible, do not panic raise the front attachment with a panic. Lowering the front attachment may be safer in most cases.

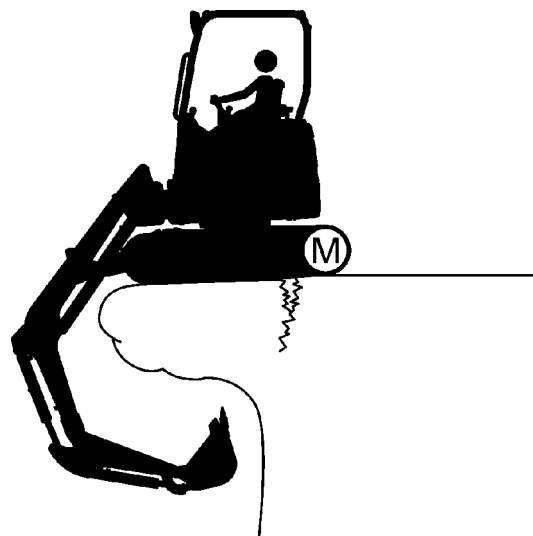

SA-1300

<https://www.ebooklibonline.com>

Hello dear friend!

Thank you very much for reading.

Enter the link into your browser.

The full manual is available for immediate download.

<https://www.ebooklibonline.com>