

編 番
PART NO.
P139-1-4

PARTS CATALOG

パーツカタログ

EX160WD

Wheeled Excavator

適用号機 1001~
Serial No.

HITACHI

メモ欄
MEMORANDUM

下表を部品注文，機械管理等にご利用下さい。

Please utilize under-table for parts-order and maintenance of your machine, etc.

機 体 製 番 MACHINE Mfg. NO.	
エ ン ジ ン 形 式 ENGINE TYPE	
エ ン ジ ン 製 番 ENGINE Mfg. NO.	

FOREWORD

- ⊙ This parts catalog shows the components of EX160WD Wheeled Hydraulic Excavator.
The numerical parts No. index is provided at the end of this parts catalog.
In the parts index, a part No. with "*" mark shows a newly added part on the parts catalog.
- ⊙ In this parts catalog, SDX and DX are mentioned on the top of some pages. Subject to territory and / or machine, supplied machines are different. When ordering parts, please confirm whether the machine is SDX or DX.
- ⊙ This parts catalog contains the most recent information available at the time of printing, and the contents of the list are based on information in effect at that time and are subject to change without notice.
- ⊙ The references in the parts catalog of "LEFT", "RIGHT", "FRONT" and "REAR" are identified as follows.
The driver's seat is positioned "LEFT" side, and the opposite side is "RIGHT".
The front attachment is at the "FRONT". The counterweight is attached at the "REAR".
For the undercarriage, the rear axle is at the "REAR", and the opposite is "FRONT".
- ⊙ For the engine parts, please refer to the parts catalog of ISUZU diesel engine 6BB1 issued separately.

1. HOW TO ORDER PARTS

When ordering parts, Please specify the following items as shown in the following example.

(EXAMPLE)		
(1) Model of Machine	(EX160WD)	} Shown on NAME-PLATE provided on MAIN FRAME on the lower right side of CAB
(2) Machine Serial No.	(139-1001)	
(3) Part No.	(A810165)	} Ordering Parts
(4) Part Name	(O-RING)	
(5) Q'ty	(2)	Ordering Q'ty
(6) Purchaser's Name and Address		

<https://www.ebooklibonline.com>

Hello dear friend!

Thank you very much for reading.

Enter the link into your browser.

The full manual is available for immediate download.

<https://www.ebooklibonline.com>

2. HOW TO USE THIS PARTS CATALOG

- ITEM Item No. Shows the reference No. on the machine illustration.

- PART NO. Part No. consists of a letter of the alphabet and numerals, or numerals only.

- PART NAME Components of an assembly part are shown with "." marks and are shown on the line, or lines, below the assembly part. Also, if the component with "." mark consists of further components part, these further components are shown by the marks ".." .

- Q'TY Q'ty shows the quantity used for one machine, however quantity of components shows the quantity for one assembly part.

- SERVICE CODE Abbreviations in the column of service code have their own meaning as shown below.
 - W: The part with this abbreviation shows that the part requires some work on it before installing in the machine.
 - H: as the part with this abbreviation shows a precision part, please ask the authority for its repairing.
 - D: The part with this abbreviation is a component of an assembly and is not available independently. The assembly part containing this part should be orderd.
 - K: This means that the part is contained in the service parts kit.
 - R: The part with this abbreviation shows that the quantity of the part is changed depending upon the machine, such as an adjusting shim etcetera.
 - S: This part is specially provided as a service part, which was not provided in the machine before from shipping the factory.
 - Z: The part with this abbreviation related to the ENGINE.
 - OP: Optional parts
 - OS: Over-sized parts
 - US: Under-sized parts

(NOTE: Part with abbreviation "OS" or "US" is described on the line below the Standard-sized part.)

 - #: The part with this mark is newly added on that page of the equipment.

- SERIAL No. Applicable machine serial No. for the part is shown in this column.
Further, above this column, the applicable serial No. is shown for all parts described on that page.
Take this serial No. if the part is not mentioned its own applicable serial No..
Take the serial No. which includes both of for the part and for all parts desclibed on the page if the part is mensioned its own applicable serial No..
If the abbreviation "D" is described as headed letter instead of the serial No. it means the producted date of the machine in which the parts are used.
(EXSAMPLE: D88/04~.....producted on April 1988 and after)

If the abbreviation "H" is described as headed letter, it means the serial No. of equipment such as PUMP, MOTOR, CONTROL VALVE and etcetera.

If the abbreviation "F" is described as headed letter, it means the Front No. of front attachment such as BUCKET, BOOM, ARM and etcetera.

-ICA

ICA shows the interchangeability between the original and the improved parts. Abbreviations used in this column are as follows.

- I: Part No. in the column of "Replaceable part" can be used instead of this part but not vice versa.
- P: This must not be used for the machine. The part No. in the column "Replaceable part" should be used instead.
- T: Parts Nos. those in the column of "Replaceable part" can be used as an assembly instead of this part.
- Y: This part and the part in the column of "Replaceable part" are interchangeable with each other.

-REPLACEABLE PART

Interchangeable parts Nos. and their required quantity are shown in this column.

NOTE: If interchangeable improved parts are provided for the parts which you may order, the improved parts classified as "I", "P", "T" or "Y" may be supplied.

名称	Name	適用号機	頁
		SERIAL NO.	PAGE
上部旋回体	SUPERSTRUCTURE		
フレーム	FRAME		001
エンジン	ENGINE		003
ラジエータ	RADIATOR		005
リザーブタンク	RESERVE TANK		007
エアクリーナ	AIR CLEANER		009
マフラー	MUFFLER		011
燃料タンク	FUEL TANK		013
ポンプ装置	PUMP DEVICE		015
旋回装置	SWING DEVICE		017
走行装置	TRAVEL DEVICE		019
オイルタンク	OIL TANK		021
オイルクーラ配管(1)	OIL COOLER PIPINGS (1)		023
オイルクーラ配管(2)	OIL COOLER PIPINGS (2)		025
オイルクーラ配管(3)	OIL COOLER PIPINGS (3)		027
本体配管(1)	MAIN PIPINGS (1)		029
本体配管(2)	MAIN PIPINGS (2)		031
本体配管(3)	MAIN PIPINGS (3)		033
エンジンコントロールレバー(1)	ENGINE CONTROL LEVER (1)		035
エンジンコントロールレバー(2)<SDX>	ENGINE CONTROL LEVER (2) <SDX>	1001~D89/01	037
エンジンコントロールレバー(2)<SDX>	ENGINE CONTROL LEVER (2) <SDX>	D89/02~	039
エンジンコントロールレバー(2)<DX>	ENGINE CONTROL LEVER (2) <DX>		041
操作レバー	CONTROL LEVER		043
走行, アウトリガレバー	TRAVEL & OUTRIGGER LEVER		045
パイロット配管(1-1)<SDX>	PILOT PIPINGS (1-1) <SDX>		047
パイロット配管(1-1)<DX>	PILOT PIPINGS (1-1) <DX>		049
パイロット配管(1-2)	PILOT PIPINGS (1-2)		051
パイロット配管(2)<SDX>	PILOT PIPINGS (2) <SDX>		053
パイロット配管(2)<DX>	PILOT PIPINGS (2) <DX>		055
パイロット配管(3-1)	PILOT PIPINGS (3-1)		057
パイロット配管(3-2)	PILOT PIPINGS (3-2)		059
パイロット配管(3-3)	PILOT PIPINGS (3-3)		061
パイロット配管(4-1)	PILOT PIPINGS (4-1)		063

名 称	Name	適用号機 SERIAL NO.	頁 PAGE
パイロット配管(4-2)	PILOT PIPINGS (4-2)		065
ステアリング	STEERING		067
ステアリング配管(旋回体)	STEERING PIPINGS (SUPERSTRUCTURE)	1001~1017	069
ステアリング配管(旋回体)	STEERING PIPINGS (SUPERSTRUCTURE)	1018~	071
エア配管(1)	AIR PIPINGS (1)		073
エア配管(2)	AIR PIPINGS (2)		075
コントロールボックス(右)	CONTROL BOX (R)		077
コントロールボックス(左)	CONTROL BOX (L)		079
ゲージパネル	GAUGE PANEL		081
電気部品(1)<SDX>	ELECTRIC PARTS (1) <SDX>		083
電気部品(1)<DX>	ELECTRIC PARTS (1) <DX>		085
電気部品(2)<SDX>	ELECTRIC PARTS (2) <SDX>		087
電気部品(2)<DX>	ELECTRIC PARTS (2) <DX>		089
電気部品(3)	ELECTRIC PARTS (3)		091
電気部品(4)	ELECTRIC PARTS (4)		093
電気部品(5)	ELECTRIC PARTS (5)		095
電気部品(6)<SDX>	ELECTRIC PARTS (6) <SDX>		097
電気部品(6)<DX>	ELECTRIC PARTS (6) <DX>		099
ウィンドウォッシャー	WINDOW WASHER		101
キャブグループ	CAB GROUP		103
・キャブ(1)	・CAB (1)		105
・キャブ(2)	・CAB (2)		107
・キャブ(3)	・CAB (3)		109
・キャブ(4)	・CAB (4)		111
・キャブ(5)	・CAB (5)		113
・キャブ(6)	・CAB (6)		115
シート	SEAT		117
カバー(1)	COVER (1)		119
カバー(2)	COVER (2)		121
カバー(3)	COVER (3)		123
カバー(4)	COVER (4)		125
・ドアロック(1)	・DOOR LOCK (1)		127
・ドアロック(2)	・DOOR LOCK (2)		129
アンダーカバー	UNDER COVER		131
カーヒータ	CAR HEATER		133
カーヒータ配管	CAR HEATER PIPINGS		135

名 称	Name	適用号機 SERIAL NO.	頁 PAGE
下部走行体		CARRIER	
シャーシ(2-O/R)	CHASSIS (2-O/R)		137
シャーシ(ブレード)	CHASSIS (BLADE)		139
パワートレイン	POWER TRAIN		141
ステアリング配管(走行体)	STEERING PIPINGS (CARRIER)		143
ブレーキ配管	BRAKE PIPINGS		145
コントロール配管	CONTROL PIPINGS		147
センタージョイント	CENTER JOINT		149
アウトリガ	OUTRIGGER		151
2-O/R配管(左右連動)	2-O/R PIPINGS (LEFT/RIGHT CONNECTION)		153
ブレード	BLADE		155
ブレード配管	BLADE PIPINGS		157
フロント		FRONT	
ブーム	BOOM		159
スタンダードアーム 2.6M	STD. ARM 2.6M		161
バケット 0.6	BUCKET 0.6		163
フロント配管	FRONT PIPINGS		165
給脂配管	LUBRICATE PIPINGS		167
工具及び予備品		TOOLS AND SPARE PARTS	
工具	TOOLS		169
予備品	SPARE PARTS		171
オプションパーツ		OPTIONAL PARTS	
燃料給油ポンプ	FUEL FEED PUMP		173
2-O/R配管(左右独立)	2-O/R PIPINGS (LEFT/RIGHT INDEPENDENT)		175
シャーシ(4-O/R シャーシ)	CHASSIS (4-O/R CHASSIS)		177
シャーシ(2-O/R, ブレード シャーシ)	CHASSIS (2-O/R & BLADE CHASSIS)		179
4-O/R配管(前後独立)	4-O/R PIPINGS (FRONT/REAR INDEPENDENT)		181
2-O/R, ブレード配管	2-O/R & BLADE PIPINGS		183
フェンダ	FENDER		185
ショートアーム 2.0M	SHORT ARM 2.0M		187
ロングアーム 3.1M	LONG ARM 3.1M		189
バケット 0.45	BUCKET 0.45		191
バケット 0.55	BUCKET 0.55		193

名 称	Name	適用号機 SERIAL NO.	頁 PAGE
バケット 0.7	BUCKET 0.7		195
バケット 0.8	BUCKET 0.8		197
梯形バケット 0.4	V-TYPE BUCKET 0.4		199
一本爪リッパ	ONE-POINT RIPPER		201
リッパバケット 0.5	RIPPER BUCKET 0.5		203
法面バケット	SLOPE-FINISHING BLADE		205
ホースラプチャバルブ配管(ブーム)	HOSE RUPTURE VALVE PIPINGS (BOOM)		207
ホースラプチャバルブ配管(アーム)	HOSE RUPTURE VALVE PIPINGS (ARM)		209
予備ペダル	SPARE PEDAL		211
予備ペダル用パイロット配管(1)	PILOT PIPINGS (1) FOR SPARE PEDAL		213
予備ペダル用パイロット配管(2)	PILOT PIPINGS (2) FOR SPARE PEDAL		215
NPKブレーカ用フロント配管	FRONT PIPINGS FOR NPK BREAKER		217
NPKブレーカ & クラッシャ用フロント配管	FRONT PIPINGS FOR NPK BREAKER & CRASHER		219
オカダ/古河ブレーカ用フロント配管	FRONT PIPINGS FOR OKADA / FURUKAWA BREAKER		221
オカダ/古河ブレーカ & クラッシャ用フロント配管	FRONT PIPINGS FOR OKADA / FURUKAWA BREAKER & CRASHER		223
合流配管	CONFLUENT PIPINGS		225
ネームプレート	NAME-PLATE		
ネームプレート(日本語)	NAME-PLATE (JAPANESE)		227
ネームプレート(英語)	NAME-PLATE (ENGLISH)		229
索 引	PARTS INDEX		231

上部旋回体
SUPERSTRUCTURE

フレーム Frame

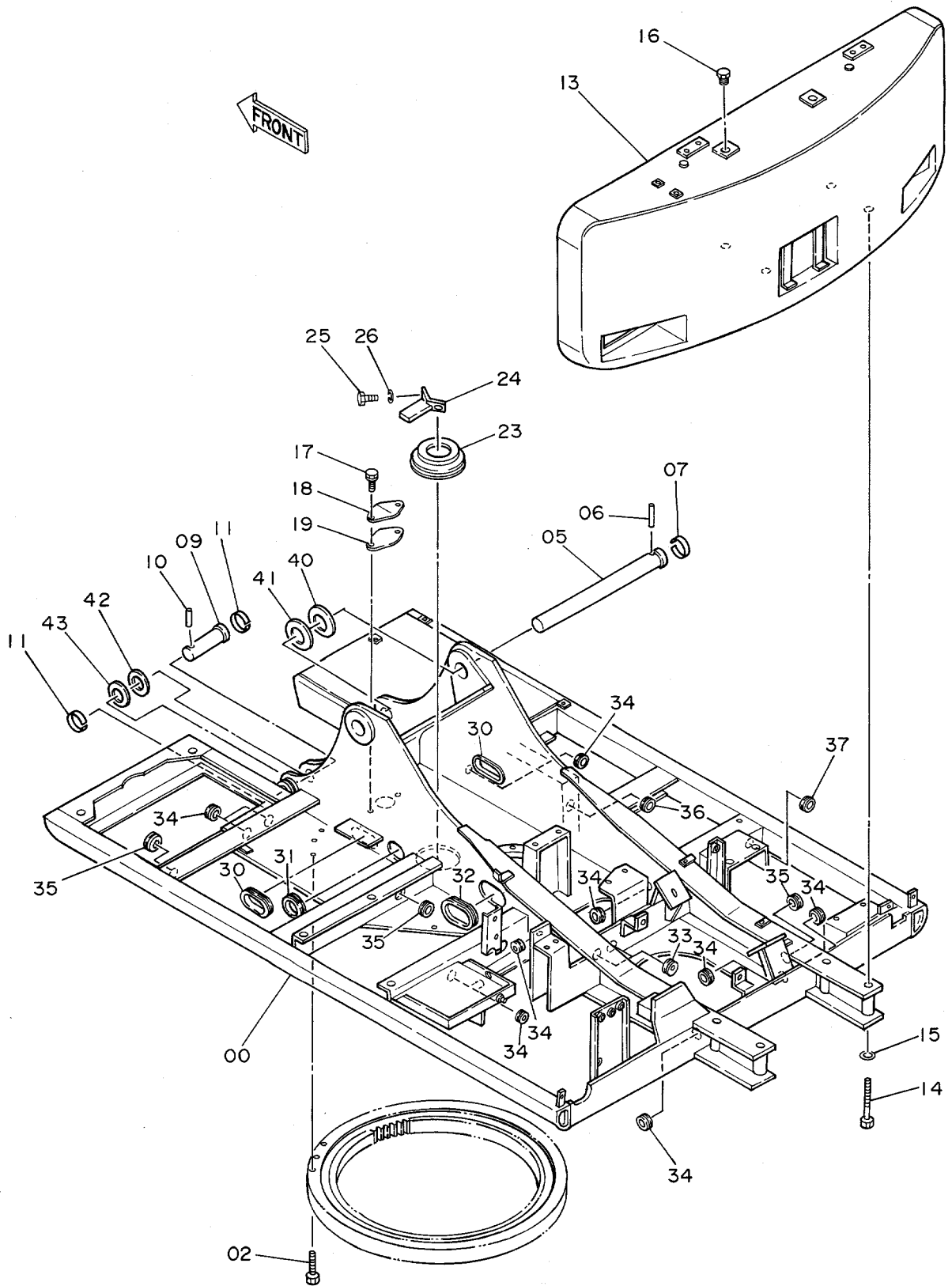

フレーム
FRAME

1001~

符号 ITEM	部品番号 PART NO.	部品名 PART NAME	or PART NAME CODE	数量 Q'TY	サービス コード S.C	適用号機 SERIAL NO.	互換性 ICA	代替部品 REPLACEABLE PART	
								部品番号 PART NO.	数量 Q'TY
00	5002151	フレーム:メイン	FRAME:MAIN	1					
02	J931895	ボルト	BOLT	30					
05	3037278	ピン	PIN	1					
06	4098713	ピン	PIN	1					
07	4098712	リング	RING	1					
09	4197535	ピン	PIN	2					
10	4098717	ピン	PIN	2					
11	4098716	リング	RING	2					
13	5002149	ウェイト:カウンタ	WEIGHT;COUNTER	1					
14	J932720	ボルト	BOLT	4					
15	4126485	ワッシャ	WASHER	4					
16	4139583	キャップ	CAP	2					
17	J021025	ボルト:セムス	BOLT;SEMS	2					
18	4013896	カバー	COVER	1					
19	4157713	パッキング	PACKING	1					
23	4208611	カバー:ラバー	COVER;RUBBER	1					
24	9728761	ストッパー	STOPPER	1					
25	J931645	ボルト	BOLT	2					
26	A590916	ワッシャ:スプリング	WASHER;SPRING	2					
30	4208984	ブッシング:ラバー	BUSHING;RUBBER	2					
31	4190960	ブッシング:ラバー	BUSHING;RUBBER	1					
32	4191978	ブッシング:ラバー	BUSHING;RUBBER	1					
33	4200176	ブッシング:ラバー	BUSHING;RUBBER	3					
34	4201995	ブッシング:ラバー	BUSHING;RUBBER	10					
35	4201749	ブッシング:ラバー	BUSHING;RUBBER	4					
36	4209294	ブッシング:ラバー	BUSHING;RUBBER	1					
37	4201995	ブッシング:ラバー	BUSHING;RUBBER	1		~ 1107			
37	4509404	ブッシング:ラバー	BUSHING;RUBBER	1		1108~			
40	4114816	シム 2.3	SHIM 2.3	1	R	~ 1065	Y	4109670	1
40	4109670	シム 2.3	SHIM 2.3	1	R	1066~			
41	4114817	シム 1.0	SHIM 1.0	1	R	~ 1065	Y	4109671	1
41	4109671	シム 1.2	SHIM 1.2	1	R	1066~			
42	4097354	シム 1.2	SHIM 1.2	2	R				
43	4097355	シム 2.3	SHIM 2.3	2	R				

エンジン Engine

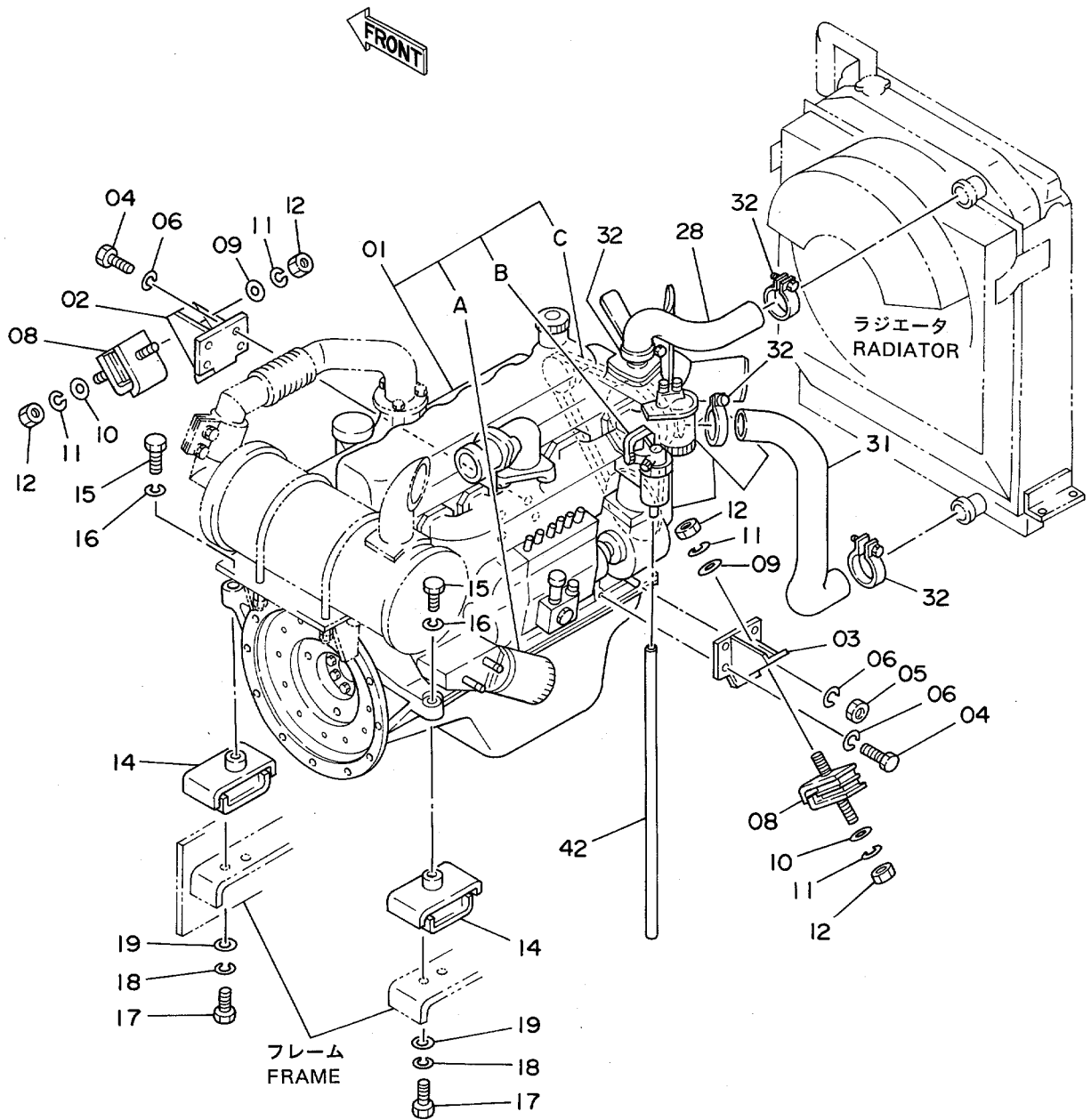

エンジン
ENGINE

1001~

符号 ITEM	部品番号 PART NO.	部品名 PART NAME	or PART NAME CODE	数量 Q'TY	サービス コード S.C	適用号機 SERIAL NO.	互換性 ICA	代替部品 REPLACEABLE PART	
								部品番号 PART NO.	数量 Q'TY
01	4189704	エンジン	ENGINE	1	Z				
01A	4206079	・フィルタ;オイル	・FILTER;OIL	1	Z				
01B	4206080	・フィルタ;フューエル	・FILTER;FUEL	1	Z				
01C	4218253	・ベルト;ファン (1=2本)	・BELT;FAN (1=2 PIECES)	1	Z				
02	8021976	ブラケット	BRACKET	1					
03	8021977	ブラケット	BRACKET	1					
04	M111025	ボルト	BOLT	7					
05	M511008	ナット	NUT	1					
06	A590910	ワッシャ;スプリング	WASHER;SPRING	8					
08	4123994	ラバー	RUBBER	2					
09	A590114	ワッシャ;プレーン	WASHER;PLANE	2					
10	4114404	ワッシャ	WASHER	2					
11	A590914	ワッシャ;スプリング	WASHER;SPRING	4					
12	J950014	ナット	NUT	4					
14	4123995	ラバー	RUBBER	2					
15	J931865	ボルト	BOLT	2					
16	A590918	ワッシャ;スプリング	WASHER;SPRING	2					
17	J901635	ボルト	BOLT	4					
18	A590916	ワッシャ;スプリング	WASHER;SPRING	4					
19	4114405	ワッシャ	WASHER	4					
28	3033624	ホース;ウォーター	HOSE;WATER	1					
31	2027522	ホース;ウォーター	HOSE;WATER	1					
32	4504198	クランプ;ホース	CLAMP;HOSE	4					
42	4171509	ホース;ビニール	HOSE;VINYL	1					

ラジエータ Radiator

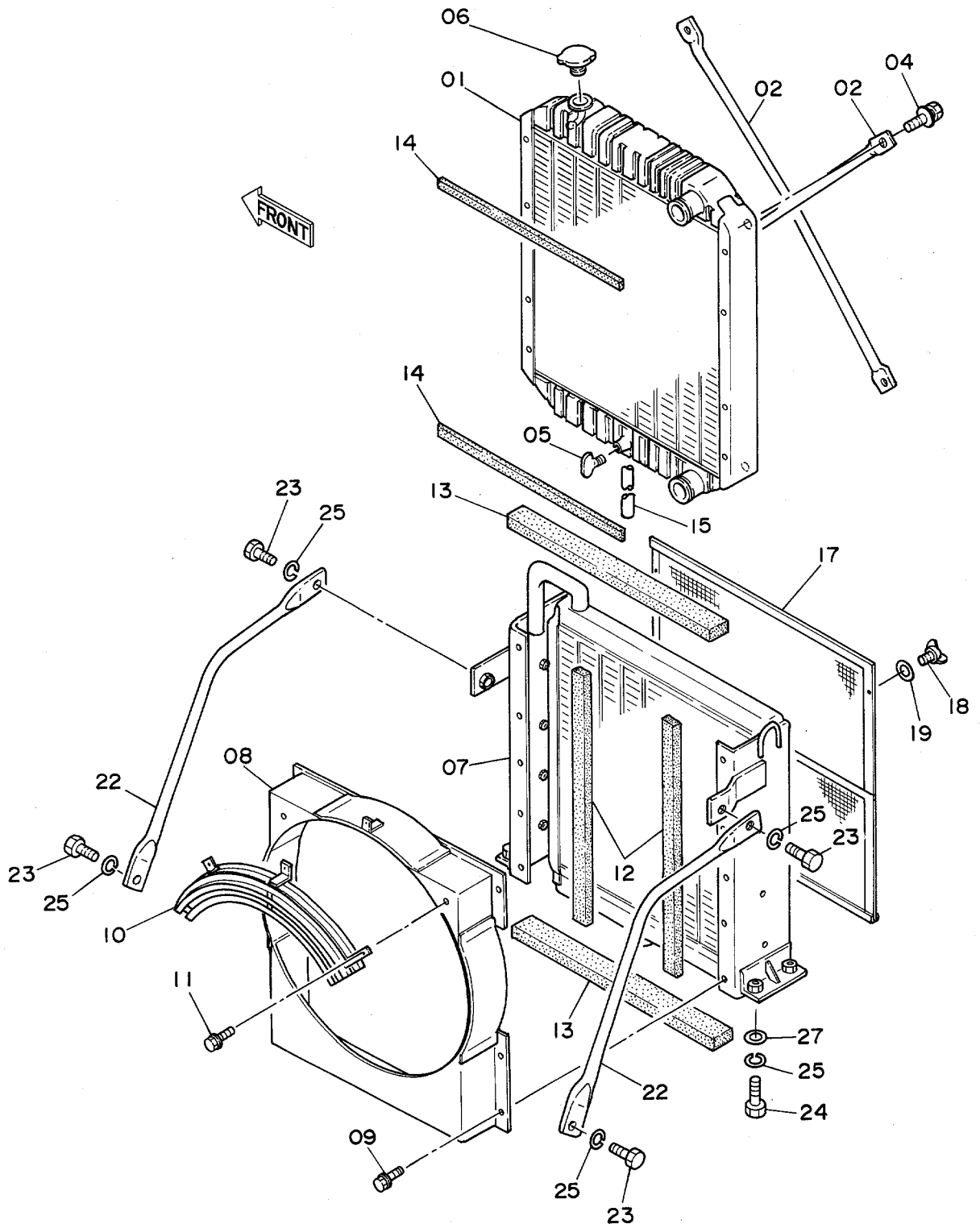

ラジエータ
RADIATOR

1001~

符号 ITEM	部品番号 PART NO.	部品名 PART NAME	or PART NAME CODE	数量 Q'TY	サービス コード S.C	適用号機 SERIAL NO.	互換性 ICA	代替部品 REPLACEABLE PART	
								部品番号 PART NO.	数量 Q'TY
01~19	4214333	ラジエータ アッセン	RADIATOR ASS'Y	1					
01	4239567	・コア;ラジエータ	・CORE;RADIATOR	1					
02	4206676	・ロッド	・ROD	2					
04	4206679	・ボルト	・BOLT	4					
05	4148705	・プラグ;ドレン	・PLUG;DRAIN	1					
06	4228160	・キャップ	・CAP	1					
07	4239568	・クーラ;オイル	・COOLER;OIL	1					
08	4239561	・ガイド;ファン	・GUIDE;FAN	1					
09	4218644	・ボルト	・BOLT	10					
10	4218258	・ガード;ファン	・GUARD;FAN	1					
11	4206128	・ボルト	・BOLT	3					
12	4206672	・パッキン	・PACKING	2					
13	4200220	・パッキン	・PACKING	2					
14	4200221	・パッキン	・PACKING	2					
15	4148706	・ホース	・HOSE	1					
17	4196945	・ネット	・NET	1					
18	4206930	・ボルト;ウイング	・BOLT;WING	4					
19	4206931	・ワッシャ	・WASHER	4					
22	3033623	ステー	STAY	2					
23	J901635	ボルト	BOLT	4					
24	J901640	ボルト	BOLT	4					
25	A590916	ワッシャ;スプリング	WASHER;SPRING	8					
27	4114405	ワッシャ	WASHER	4					

リザーブタンク Reserve Tank

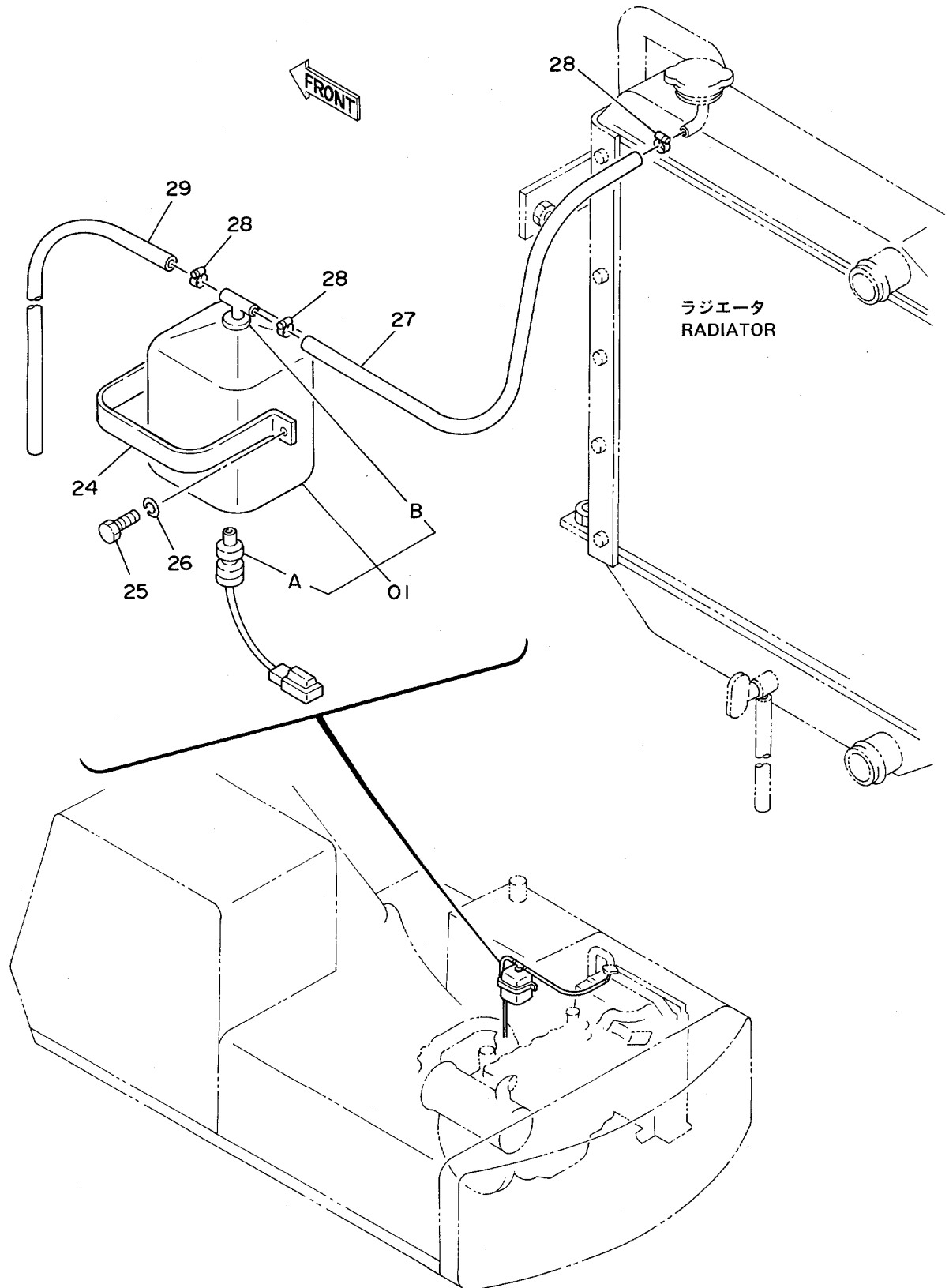

エアクリーナ Air Cleaner

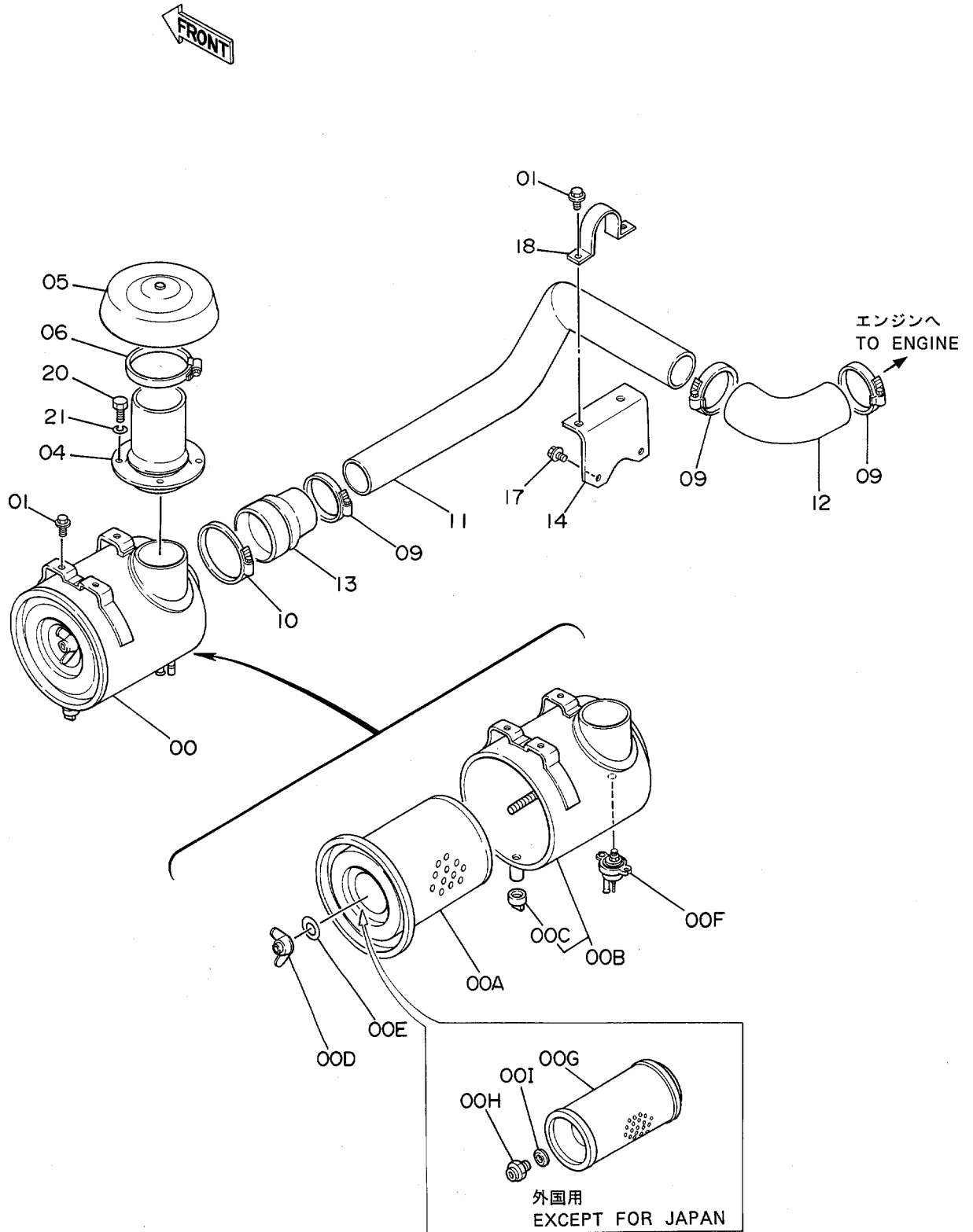

エアクリナ
AIR CLEANER

1001~

符号 ITEM	部品番号 PART NO.	部 品 名 PART NAME	or PART NAME CODE	数量 Q'TY	サービス コード S.C	適用号機 SERIAL NO.	互 換 性 ICA	代 替 部 品 REPLACEABLE PART	
								部品番号 PART NO.	数量 Q'TY
00A~F ,	4178600	クリナ;エア (日本国内用)	CLEANER;AIR (FOR JAPAN)	1					
00A~I ,	4209599	クリナ;エア (日本国外用)	CLEANER;AIR (EXCEPT FOR JAPAN)	1					
00A	4206098	・エレメント	・ELEMENT	1					
00B	4206551	・ボディ	・BODY	1					
00C	4206552	・バルブ	・VALVE	1					
00D	4206553	・ナット;ウイング	・NUT;WING	1					
00E	4206554	・パッキン	・PACKING	1					
00F	4148963	・インジケータ	・INDICATOR	1					
00G ,	4209588	・エレメント (日本国外用)	・ELEMENT (EXCEPT FOR JAPAN)	1					
00H ,	4178406	・ナット (日本国外用)	・NUT (EXCEPT FOR JAPAN)	1					
00I ,	4178404	・パッキン (日本国外用)	・PACKING (EXCEPT FOR JAPAN)	1					
01	J011020	ボルト;セムス	BOLT;SEMS	5					
04	8034717	パイプ	PIPE	1					
05	4188642	キャップ	CAP	1					
06	4507397	クランプ;ホース	CLAMP;HOSE	1					
09	4507512	クランプ;ホース	CLAMP;HOSE	3					
10	4507397	クランプ;ホース	CLAMP;HOSE	1					
11	8040405	パイプ;インレット	PIPE;INLET	1					
12	984204	ホース;ラバー	HOSE;RUBBER	1					
13	4215192	ホース;エア	HOSE;AIR	1					
14	3027134	ブラケット	BRACKET	1					
17	J010820	ボルト;セムス	BOLT;SEMS	2					
18	4000909	クランプ;パイプ	CLAMP;PIPE	1					
20	J901220	ボルト	BOLT	4					
21	A590912	ワッシャー;スプリング	WASHER;SPRING	4					

マフラー Muffler

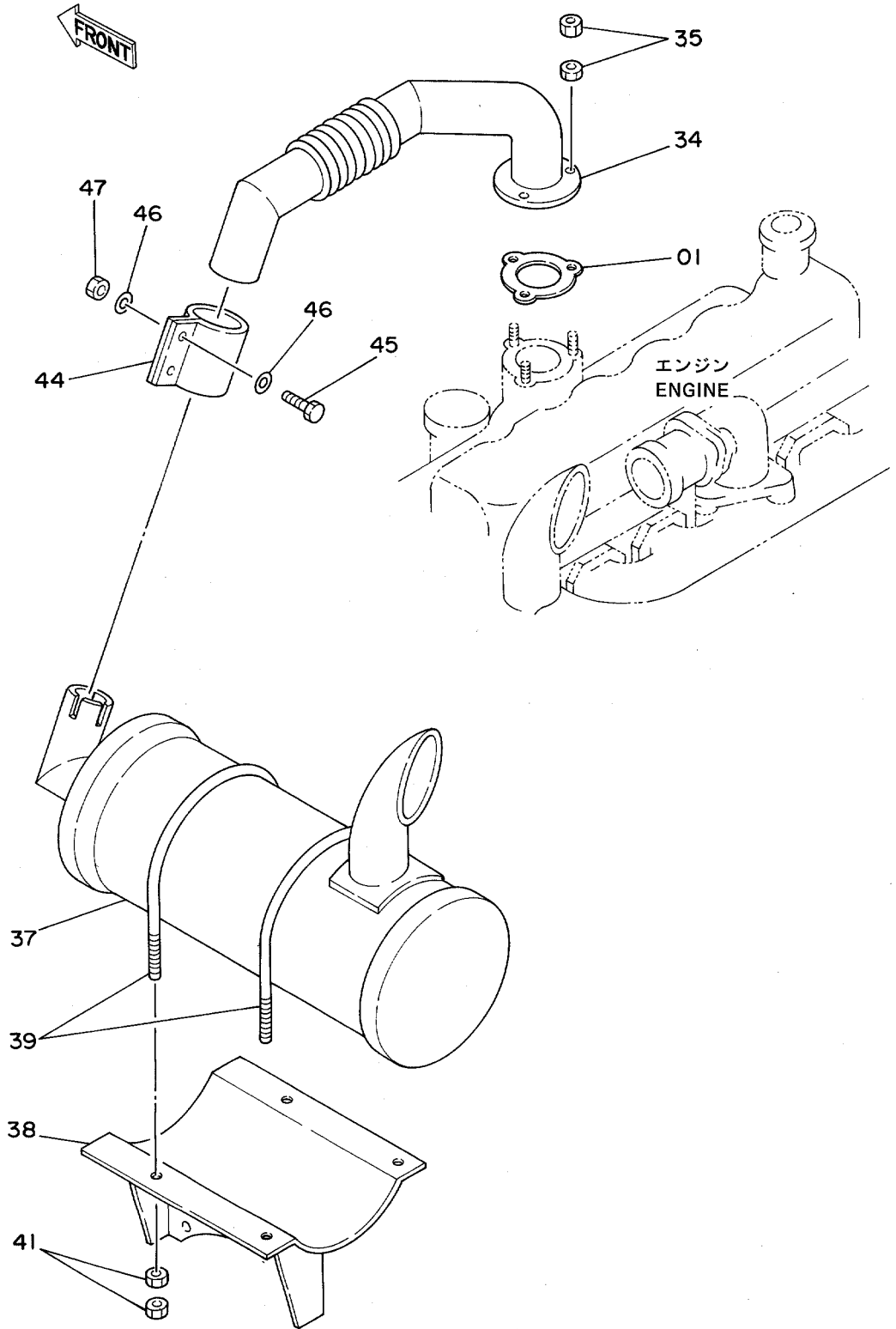



Suggest:

For more complete manuals. Please go to the home page.

<https://www.ebooklibonline.com>

If the above button click is invalid. Please download this document first, and then click the above link to download the complete manual.

Thank you so much for reading

<https://www.ebooklibonline.com>

Hello dear friend!

Thank you very much for reading.

Enter the link into your browser.

The full manual is available for immediate download.

<https://www.ebooklibonline.com>