

# Operator's Manual

# **EH350ACII**

## **Rigid Dump Truck**

# INDEX

MACHINE NUMBERS

SAFETY

SAFETY SIGNS

COMPONENTS NAME

GETTING ON/OFF MACHINE

EMERGENCY EXIT

OPERATOR'S STATION

BREAK-IN

OPERATING ENGINE

DRIVING MACHINE

OPERATING MACHINE

MAINTENANCE

MAINTENANCE UNDER SPECIAL ENVIRONMENTAL CONDITIONS

STORAGE

TROUBLESHOOTING

SPECIFICATIONS

INDEX

# CONTENTS

## MACHINE NUMBERS

### SAFETY

Recognize Safety Information .....	S-1
Understand Signal Words.....	S-1
Follow Safety Instructions.....	S-2
Prepare for Emergencies.....	S-2
Wear Protective Clothing.....	S-3
Protect Against Noise .....	S-3
Inspect Machine .....	S-3
General Precautions for Cab.....	S-4
Use Handholds and Steps .....	S-4
Operator's Visibility .....	S-5
Adjust Operator's Seat.....	S-6
Fasten Your Seat Belt.....	S-6
Move and Operate Machine Safely.....	S-7
Handle Starting Aids Safely .....	S-7
Operate Only from Operator's Seat .....	S-8
Jump Starting .....	S-8
Keep Riders Off Machine .....	S-8
Avoid Injury Caused by High Tension Electric Shock .....	S-9
Investigate Job Site Beforehand .....	S-9
Provide Signals for Jobs Involving Multiple Machines.....	S-9
Drive Machine Safely.....	S-10
Wheel Maintenance.....	S-11
Drive on Snow Safely .....	S-12
Avoid Injury from Rollaway Accidents.....	S-12
Avoid Injury from Back-Over Accidents .....	S-13
Keep Person Clear from Working Area.....	S-13
Avoid Tipping.....	S-14
Protect Against Falling Stones and Debris .....	S-15
Operate with Caution .....	S-15
Avoid Power Lines.....	S-15
Precautions for Lightning.....	S-16
Avoid Overloading .....	S-16
Protect Against Flying Debris .....	S-17
Park Machine Safely.....	S-17
Prevent Unintended Machine Movement.....	S-18
Handle Fluids Safely – Avoid Fires .....	S-18
Practice Safe Maintenance.....	S-19
Warn Others of Service Work .....	S-20
Support Machine Properly.....	S-20
Stay Clear of Moving Parts .....	S-20
Prevent Parts from Flying .....	S-21
Prevent Burns.....	S-21
Replace Rubber Hoses Periodically.....	S-22
Avoid High-Pressure Fluids .....	S-22
Prevent Fires.....	S-23
Evacuating in Case of Fire.....	S-24
Beware of Exhaust Fumes.....	S-24
Precautions for Welding and Grinding .....	S-25
Avoid Heating Near Pressurized Fluid Lines .....	S-25
Avoid Applying Heat to Lines Containing Flammable Fluids .....	S-25
Remove Paint Before Welding or Heating .....	S-26
Beware of Asbestos Dust .....	S-26
Prevent Battery Explosions .....	S-27
Service Air Conditioning System Safely .....	S-27
Handle Chemical Products Safely.....	S-28
Dispose of Waste Properly.....	S-28
<b>SAFETY SIGNS.....</b>	<b>S-29</b>
<b>COMPONENTS NAME .....</b>	<b>1-1</b>
<b>GETTING ON/OFF MACHINE.....</b>	<b>1-2</b>
<b>EMERGENCY EXIT</b>	
Emergency Exit .....	1-3
Evacuating in Case of Fire.....	1-4
<b>OPERATOR'S STATION</b>	
Cab Features.....	1-6
Monitor Display.....	1-7
How to Use Screens .....	1-7
How to Use Key Pad.....	1-9
Basic Screen.....	1-10
Engine Related Warning Indicators.....	1-13
Driving Related Warning Indicators.....	1-16
Hydraulic Related Warning Indicators .....	1-20
Light Indicators .....	1-23
Miscellaneous Indicator.....	1-24
Alarm Occurrence Screen.....	1-26
Clock Setting.....	1-27
Head Lights/Front Combination Lights/Horns.....	1-29
Side Lights.....	1-30
Rear Lights .....	1-31
Maintenance Lights.....	1-32
Steering Wheel.....	1-33
Horn Switch.....	1-33
Turn Signal/High Beam Lever Switch.....	1-33
Hazard Warning Lamp Switch.....	1-34
Tilt/Telescope Steering Wheel .....	1-34
Accelerator Pedal.....	1-34
Service Brake Pedal.....	1-35
Retarder Brake Pedal.....	1-36
Parking Brake .....	1-36
Center Console.....	1-37
Hoist Lever .....	1-39
Console Panel .....	1-41
Dome Light Switch .....	1-47
Sun Visor .....	1-47
Air Conditioner.....	1-48
Designations and Functions of the Control Panel.....	1-49
Cooling.....	1-50
Heating.....	1-51
Dehumidifying and Heating.....	1-51
Defrosting .....	1-51
Blower Operation Without Cooling or Heating .....	1-52
Ventilation of the Cab .....	1-52
AM/FM Radio Operation .....	1-53
Digital Clock Setting Procedure .....	1-54
Camera Monitor .....	1-55
Adjusting Operator's Seat .....	1-56
Adjusting Trainer's Seat.....	1-59

**<https://www.ebooklibonline.com>**

Hello dear friend!

Thank you very much for reading.

Enter the link into your browser.

The full manual is available for immediate download.

**<https://www.ebooklibonline.com>**

# CONTENTS

Seat Belt.....	1-60	B. Engine.....	7-21
Cab Door Lock.....	1-61	Check Engine Oil Level.....	7-22
Opening/Closing Cab Left Door.....	1-61	Change Engine Oil.....	7-23
Electrical Equipment Box (Behind Cab).....	1-62	Replace Engine Oil Filters.....	7-23
Deck upper Relay Box.....	1-65	C. Travel Reduction Gear.....	7-25
<b>BREAK-IN</b>		Check Gear Oil Level.....	7-26
Observe Machine Closely.....	2-1	Change Gear Oil.....	7-27
Every 10 Hours or Each Shift.....	2-1	Replace Gear Oil Filter.....	7-27
After the First 50 Hours.....	2-1	Clean and Replace Breather.....	7-28
<b>OPERATING ENGINE</b>		Clean Oil Cooler.....	7-28
Inspect Machine Daily Before Starting.....	3-1	D. Hydraulic System.....	7-29
Before Starting Engine.....	3-2	Inspection and Maintenance of	
System Check.....	3-3	Hydraulic Equipment.....	7-30
Starting Engine in Normal Temperature.....	3-4	Check Hydraulic Oil Level.....	7-32
Starting in Cold Weather.....	3-5	Drain Hydraulic Oil Tank Sump.....	7-33
Check Instruments After Starting.....	3-6	Replace Full-Flow Filter Element.....	7-34
Using Booster Batteries.....	3-7	Replace Line Filter Element.....	7-36
Stopping Engine.....	3-9	Change Hydraulic Oil.....	7-38
<b>DRIVING MACHINE</b>		Suction Filter Cleaning.....	7-38
Drive Machine Carefully.....	4-1	Check Hoses and Lines.....	7-41
Starting.....	4-2	Service Recommendations for Hydraulic Fittings.....	7-44
Propel Change.....	4-3	E. Fuel System.....	7-47
Acceleration.....	4-3	Drain Fuel Tank Sump.....	7-49
Cruise Control.....	4-4	Drain Fuel Filter.....	7-49
Deceleration.....	4-6	Replace Fuel Filter Element.....	7-50
Retarder Brake.....	4-6	Replace Fuel Filter.....	7-51
Auto Retarder.....	4-7	Check Fuel Hoses.....	7-52
Steering.....	4-9	Clean Fuel Tank Breather.....	7-53
Stopping Machine.....	4-10	F. Air Cleaner.....	7-54
Parking Machine.....	4-11	Clean Air Cleaner Outer Element.....	7-54
Towing.....	4-12	Replace Air Cleaner Outer and Inner Elements.....	7-54
<b>OPERATING MACHINE</b>		Clean Air Cleaner Dust Cups.....	7-56
Loading.....	5-1	G. Cooling System.....	7-57
Load Weighing System.....	5-2	Check Coolant Level.....	7-58
Hauling.....	5-3	Check DCA4 Concentration in Coolant.....	7-59
Dumping.....	5-4	Replace Coolant Filter.....	7-67
Speed Limitation Function While Dump Body is		Change Coolant.....	7-68
Raised.....	5-7	Clean Radiator, After Cooler Interior.....	7-68
Deactivation of Speed Limitation Function in an		Clean Radiator, After Cooler Core.....	7-69
Emergency.....	5-7	Check Fan Belt for Wear.....	7-69
<b>MAINTENANCE</b>		H. Air Conditioner.....	7-70
Correct Maintenance and Inspection Procedures.....	7-1	Clean and Replace Recirculation Air Filter.....	7-70
Check Hour Meter Regularly.....	7-2	Clean and Replace Ventilation Air Filter.....	7-71
Use Correct Fuels and Lubricants.....	7-2	Check Refrigerant Quantity.....	7-72
Prepare Machine for Maintenance.....	7-3	Check Compressor Belt Tension.....	7-73
Installing Body Prop Pins.....	7-5	Clean Condenser Core.....	7-74
Removal and Storage of Dump Body Prop pins.....	7-6	Check Tightening Torque.....	7-75
Inspection/Maintenance Lights.....	7-7	Seasonal Maintenance.....	7-76
Main Part/Component Location Diagram.....	7-9	I. Electrical System.....	7-77
Periodic Replacement of Parts.....	7-10	Batteries.....	7-77
Hydraulic System.....	7-11	Replacing Fuses.....	7-82
Maintenance Guide.....	7-13	Check Fusible Link.....	7-86
A. Greasing.....	7-18	Check Electrical Cables and Wire Harnesses.....	7-87
		Check Emergency Engine Stop Switch.....	7-89
		Check Lights.....	7-90
		Check Horn and Backup Alarm Buzzer.....	7-90

# CONTENTS

---

Check Suspension Pressure Sensor.....	7-91	<b>SPECIFICATIONS</b>	
J. Brakes & Steering System.....	7-93	Specifications.....	12-1
Check Brake Operation.....	7-93	Hitachi Loading Policy.....	12-2
Check Service Brake.....	7-93	<b>INDEX</b> .....	14-1
Check Parking Brake.....	7-94		
Check Accumulator.....	7-95		
Check Front/Rear Brake Lining.....	7-97		
Check Front/Rear Brake Disk.....	7-97		
K. Suspension, Wheels & Tires.....	7-98		
Check Suspension.....	7-99		
Check Wheels.....	7-100		
Check Front Axle.....	7-101		
Check Front Wheel Lubricant.....	7-101		
Change Front Wheel Lubricant.....	7-101		
Check Tire Inflation Pressure.....	7-102		
Check Tire Condition.....	7-103		
Check Wheel Alignment.....	7-103		
L. Miscellaneous.....	7-104		
Check, Clean and Replace Alternator			
Carbon Brush.....	7-104		
Check and Change Coolant in the Control			
Cabinet.....	7-107		
Clean and Replace Pressurized Control Cabinet			
Filter.....	7-108		
Clean Rear Axle Inside.....	7-109		
Check and Replace Seat Belt.....	7-109		
Check Windshield Washer Tank.....	7-109		
Check Play Amount in Steering Wheel Stroke.....	7-110		
Auto-Lubrication System.....	7-111		
Check Tightening Torque of Bolts and Nuts.....	7-113		
<b>MAINTENANCE UNDER SPECIAL</b>			
<b>ENVIRONMENTAL CONDITIONS</b> .....	9-1		
<b>STORAGE</b>			
Storing Machine.....	10-1		
Removing Machine From Storage.....	10-2		
<b>TROUBLESHOOTING</b>			
Cummins Fault Code Lamps and Diagnostic			
Switches.....	11-1		
Engine.....	11-2		
Electrical System.....	11-5		
Hydraulic System.....	11-8		
Hydraulic Hoist System.....	11-10		
Hydraulic Steering System.....	11-10		
Steering Pump.....	11-11		
Steering Control Valve.....	11-12		
Front Axle.....	11-13		
Rear Axle.....	11-14		
Hoist Pump Driveline.....	11-14		
Rear Axle Planetary.....	11-15		
Parking Brake.....	11-15		
Alternator.....	11-16		
Wheel Motor.....	11-16		
Blower Motor.....	11-17		

---



## MACHINE NUMBERS

The manufacturing Nos. explained in this group is the individual number (serial No.) given to each machine and hydraulic components. These numbers are requested when inquiring any information on the machine and/or components. Fill these serial Nos. in the blank spaces in this group to immediately make them available upon request.

### Machine

MODEL/TYPE: \_\_\_\_\_

PRODUCT  
IDENTIFICATION  
NUMBER: \_\_\_\_\_

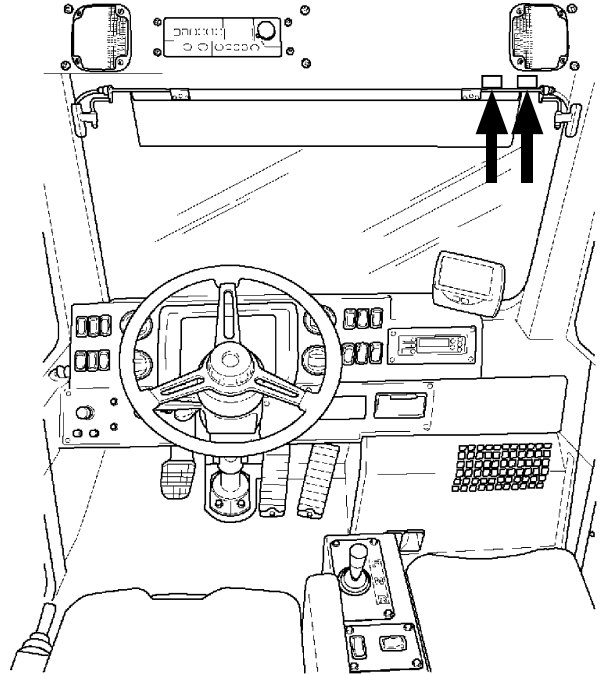
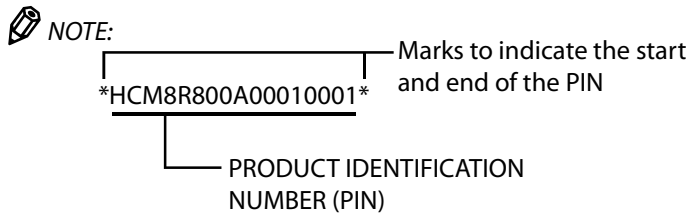

M8R8-01-105

### Rollover Protective Structure Cab Name Plate

MODEL/TYPE: \_\_\_\_\_

ROPS  
MODEL  
NUMBER: \_\_\_\_\_

MAX  
MACHINE  
MASS, M-kg: \_\_\_\_\_

# MACHINE NUMBERS

---

## Engine

TYPE: \_\_\_\_\_

MFG. NO.: \_\_\_\_\_

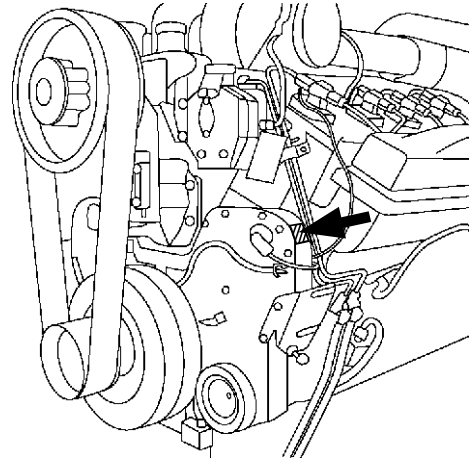

M8R8-00-025

## Wheel Motor

TYPE: \_\_\_\_\_

MFG. NO. (LEFT): \_\_\_\_\_

MFG. NO. (RIGHT): \_\_\_\_\_

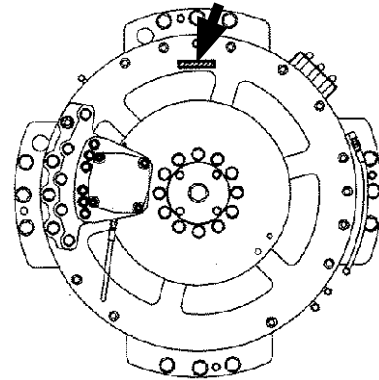

M8R8-00-028

## Alternator

TYPE: \_\_\_\_\_

MFG. NO.: \_\_\_\_\_

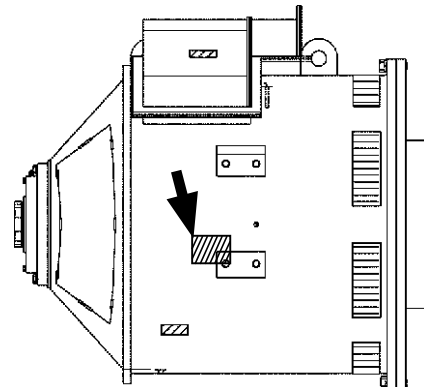

M8R8-00-027

---

# MACHINE NUMBERS

---

## Control Cabinet

TYPE: \_\_\_\_\_

MFG. NO.: \_\_\_\_\_

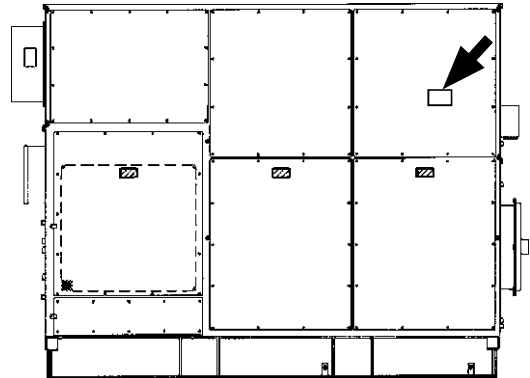

M8R8-00-007

## Hydraulic Pump

TYPE: \_\_\_\_\_

MFG. NO.: \_\_\_\_\_

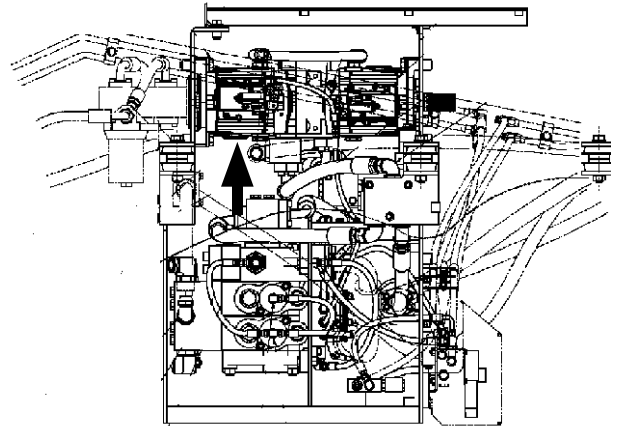

M8R8-00-029

## Control Valve

TYPE: \_\_\_\_\_

MFG. NO.: \_\_\_\_\_

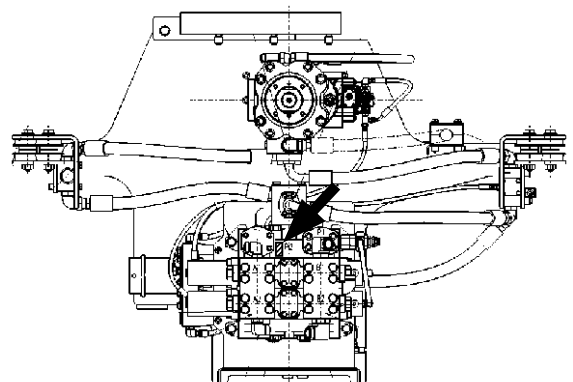

M8R8-00-030

---

# MACHINE NUMBERS

---

## Travel Reduction Gear

TYPE: \_\_\_\_\_

MFG. NO. (LEFT): \_\_\_\_\_

MFG. NO. (RIGHT): \_\_\_\_\_

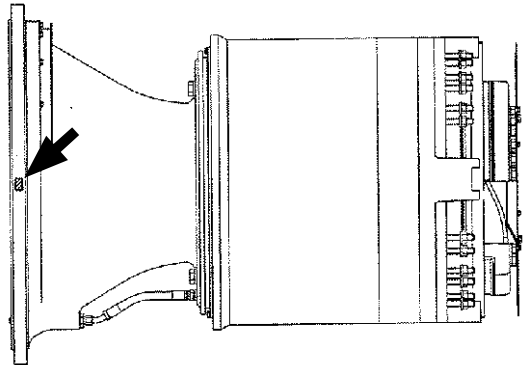

M8R8-00-031

---

## SAFETY

---

### Recognize Safety Information

- These are the **SAFETY ALERT SYMBOLS**.
  - When you see these symbols on your machine or in this manual, be alert to the potential for personal injury.
  - Follow recommended precautions and safe operating practices.



SA-688

### Understand Signal Words

- On machine safety signs, signal words designating the degree or level of hazard - **DANGER**, **WARNING**, or **CAUTION** - are used with the safety alert symbol.
  - **DANGER** indicates an imminently hazardous situation which, if not avoided, will result in death or serious injury.
  - **WARNING** indicates a potentially hazardous situation which, if not avoided, could result in death or serious injury.
  - **CAUTION** indicates a potentially hazardous situation which, if not avoided, may result in minor or moderate injury.
  - **DANGER or WARNING safety signs** are located near specific hazards. General precautions are listed on **CAUTION safety signs**.
  - Some safety signs do not use any of the designated signal words above after the safety alert symbol are occasionally used on this machine.
- To avoid confusing machine protection with personal safety messages, a signal word **IMPORTANT** indicates a situation which, if not avoided, could result in damage to the machine.
-  **NOTE** indicates an additional explanation for an element of information.



**IMPORTANT**



SA-1223

## SAFETY

---

### Follow Safety Instructions

- Carefully read and follow all safety signs on the machine and all safety messages in this manual.
- Safety signs should be installed, maintained and replaced when necessary.
  - If a safety sign or this manual is damaged or missing, order a replacement from your authorized dealer in the same way you order other replacement parts (be sure to state machine model and serial number when ordering).
- Learn how to operate the machine and its controls correctly and safely.
- Allow only trained, qualified, authorized personnel to operate the machine.
- Keep your machine in proper working condition.
  - Unauthorized modifications of the machine may impair its function and/or safety and affect machine life.
- The safety messages in this SAFETY chapter are intended to illustrate basic safety procedures of machines. However it is impossible for these safety messages to cover every hazardous situation you may encounter. If you have any questions, you should first consult your supervisor and/or your authorized dealer before operating or performing maintenance work on the machine.

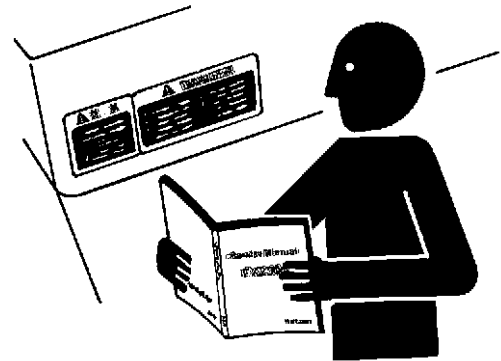

SA-003

---

### Prepare for Emergencies

- Be prepared if a fire starts or if an accident occurs.
  - Keep a first aid kit and fire extinguisher on hand.
  - Thoroughly read and understand the label attached on the fire extinguisher to use it properly.
  - To ensure that a fire-extinguisher can be always used when necessary, check and service the fire-extinguisher at the recommended intervals as specified in the fire-extinguisher manual.
  - Establish emergency procedure guidelines to cope with fires and accidents.
  - Keep emergency numbers for doctors, ambulance service, hospital, and fire department posted near your telephone.

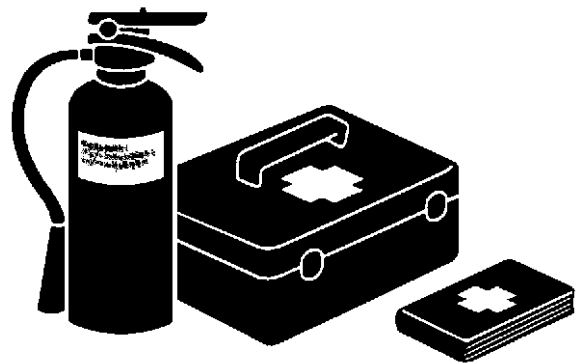

SA-437

## SAFETY

---

### Wear Protective Clothing

- Wear close fitting clothing and safety equipment appropriate to the job.

You may need:

- A hard hat
- Safety shoes
- Safety glasses, goggles, or face shield
- Heavy gloves
- Hearing protection
- Reflective clothing
- Wet weather gear
- Respirator or filter mask.

Be sure to wear the correct equipment and clothing for the job. Do not take any chances.

- Avoid wearing loose clothing, jewelry, or other items that can catch on control levers or other parts of the machine.
- Operating equipment safely requires the full attention of the operator. Do not wear radio or music headphones while operating the machine.

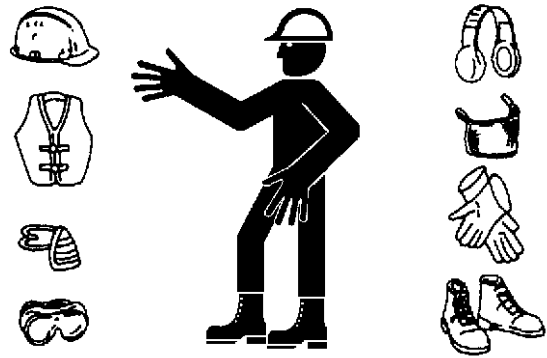

SA-438

---

### Protect Against Noise

- Prolonged exposure to loud noise can cause impairment or loss of hearing.
- Wear a suitable hearing protective device such as earmuffs or earplugs to protect against objectionable or uncomfortably loud noises.



SA-434

---

### Inspect Machine

- Inspect your machine carefully each day or shift by walking around it before you start it to avoid personal injury.
- In the walk-around inspection, be sure to cover all points described in the "INSPECT MACHINE DAILY BEFORE STARTING" chapter in the operator's manual.



SA-435

## SAFETY

---

### General Precautions for Cab

- Before entering the cab, thoroughly remove all dirt and/or oil from the soles of your work boots. If any controls such as a pedal is operated while with dirt and/or oil on the soles of the operator's work boots the operator's foot may slip off the pedal, possibly resulting in a personal accident.
- Do not leave parts and/or tools lying around the operator's seat. Store them in their specified locations.
- Avoid storing transparent bottles in the cab. Do not attach any transparent type window decorations on the windowpanes as they may focus sunlight, possibly starting a fire.
- Refrain from listening to the radio, or using music headphones or mobile telephones in the cab while operating the machine.
- Keep all flammable objects and/or explosives away from the machine.
- After using the ashtray, always cover it to extinguish the match and/or tobacco.
- Do not leave cigarette lighters in the cab. When the temperature in the cab increases, the lighter may explode.

---

### Use Handholds and Steps

- Falling is one of the major causes of personal injury.
  - When you get on and off the machine, always face the machine and maintain a three-point contact with the steps and handrails.
  - Do not use any controls as handholds.
  - Never jump on or off the machine. Never mount or dismount a moving machine.
  - Be careful of slippery conditions on platforms, steps, and handrails when leaving the machine.
  - Do not step or climb on surfaces, which are not intended for walking. Step only on the areas provided with the slip resistant surfaces.



SA-439

# SAFETY

## Operator's Visibility

- This machine is equipped with mirrors and cameras to see around the machine. Adjust the view mirrors and cameras position so that the best visibility is obtained from the operator's seat. If the mirrors and cameras are dirty, immediately clean them. Also see carefully around the machine while moving your viewpoint as need arises.
- The view mirrors and cameras position should be adjusted whenever changing the operator for the machine. Always take extra attention for surrounded area during operating.
- When the machine is modified or fitted with equipment that influences visibility, it is necessary to check again the operator's visibility according to the ISO 5006. Contact your authorized dealer before modifying the machine.
- This machine has the blind area created because of parts of the base machine and/or its equipment from the operator's seat by direct.
- Operate the machine safely with sufficient recognition this machine has blind area from the operator's seat by direct.
- The operator's visibility according to the ISO 5006 of this machine with standard mirrors and cameras is as follows.

### Operator's visibility on a rectangular 1 m boundary close around the machine

Operator can see the entire circumference of the height 1.5 m located at 1 m distance from the outside rectangular boundary of the machine as illustrated.

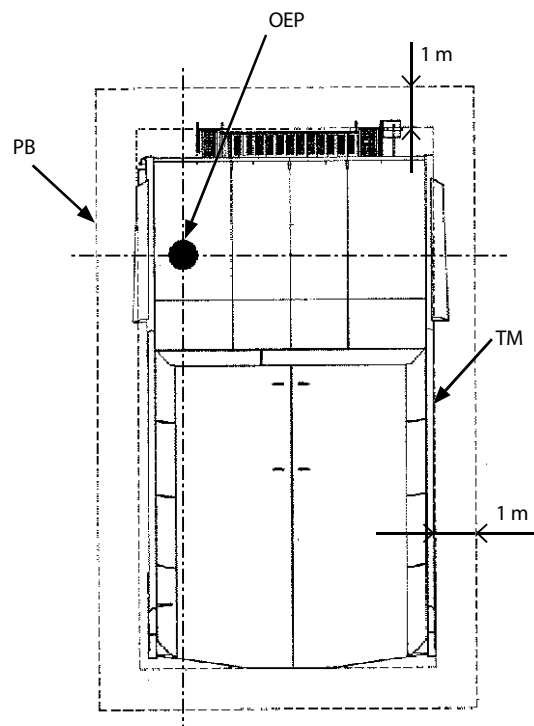

SS-3231

### Operator's visibility on a 12 m visibility test circle

Operator can see the entire circumference located the circle with 12 m radius located on the ground reference plane with its center vertically below the operator's eye point as illustrated.

- TM: test machine
- RB: rectangular 1 m boundary
- VTC: visibility test circle with 12 m radius
- OEP: operator's eye point

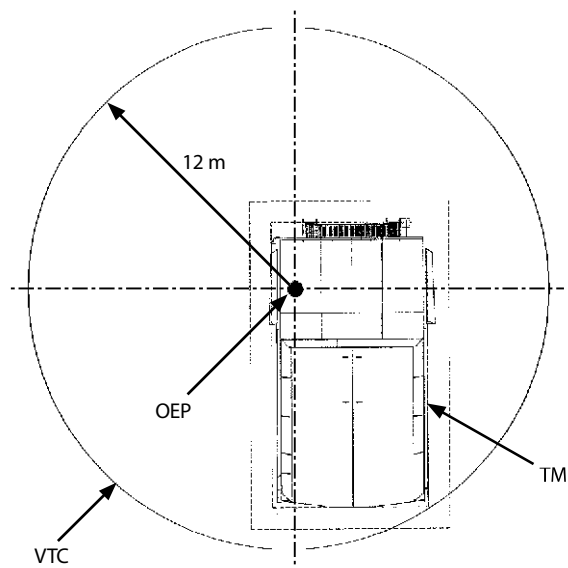

SS-3232

## SAFETY

---

### Adjust Operator's Seat

- A poorly adjusted seat for either the operator or the work at hand may quickly fatigue the operator leading to misoperations.
  - The seat should be adjusted whenever changing the operator for the machine.
  - The operator should be able to fully depress the pedals and to correctly operate the steering wheel with his back against the seat back.
  - If not, move the seat forward or backward, and check again.
  - Adjust the mirror position so that the best rear visibility is obtained from the operator's seat. If the mirror is broken, immediately replace it with a new one.



SA-462

---

### Fasten Your Seat Belt

- If the machine should overturn, the operator may become injured and/or thrown from the cab. Additionally the operator may be crushed by the overturning machine, resulting in serious injury or death.
  - Prior to operating the machine, thoroughly examine webbing, buckle and attaching hardware. If any item is damaged or worn, replace the seat belt or component before operating the machine.
  - Be sure to remain seated with the seat belt securely fastened at all times when the machine is in operation to minimize the chance of injury from an accident.
  - We recommend that the seat belt is replaced every three years regardless of its apparent condition.

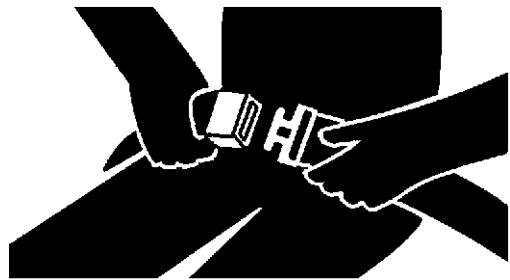

SA-237

## SAFETY

---

### Move and Operate Machine Safely

- Bystanders can be run over.
  - Take extra care not to run over bystanders. Confirm the location of bystanders before moving, or operating the machine.
  - Always keep the travel alarm and horn in working condition (if equipped). It warns people when the machine starts to move.
  - Use a signal person when moving, or operating the machine in congested areas. Coordinate hand signals before starting the machine.
  - Use appropriate illumination. Check that all lights are operable before operating the machine. If any faulty illumination is present, immediately repair it.
  - Always keep the cab door closed while operating the machine.

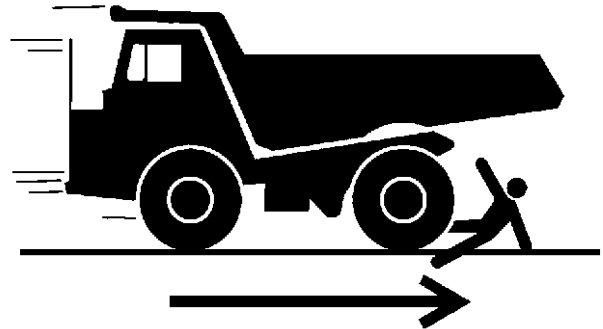

SA-1598

---

### Handle Starting Aids Safely

Starting fluid:

- Starting fluid is highly flammable.
  - Keep all sparks and flame away when using it.
  - Keep starting fluid well away from batteries and cables.
  - Remove container from machine if engine does not need starting fluid.
  - To prevent accidental discharge when storing a pressurized container, keep the cap on the container, and store it in a cool, well-protected location.
  - Do not incinerate or puncture a starting fluid container.



SA-293

## SAFETY

---

### Operate Only from Operator's Seat

- Inappropriate engine starting procedures may cause the machine to runaway, possibly resulting in serious injury or death.
  - Start the engine only when seated in the operator's seat.
  - NEVER start the engine while standing on the platform.
  - Do not start engine by shorting across starter terminals.
  - Check that the parking brake switch is turned ON.
  - Before starting the engine, confirm that shift lever is in the NEUTRAL position.
  - Before starting the engine, confirm the safety around the machine and sound the horn to alert bystanders.



SA-1599

---

### Jump Starting

- Battery gas can explode, resulting in serious injury.
  - If the engine must be jump started, be sure to follow the instructions shown in the "OPERATING ENGINE" chapter.
  - The operator must be in the operator's seat so that the machine will be under control when the engine starts. Jump starting is a two-person operation.
  - Never use a frozen battery.
  - Failure to follow correct jump starting procedures could result in a battery explosion or a runaway machine.

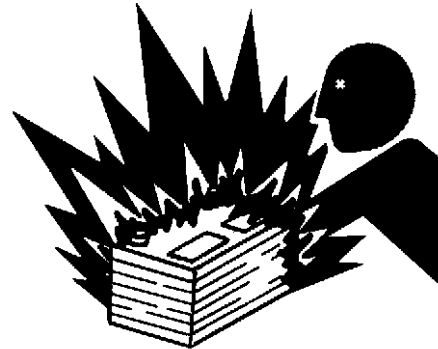

SA-032

---

### Keep Riders Off Machine

- Riders on machine are subject to injury such as being struck by foreign objects and being thrown off the machine.
  - Only allow the operator on the machine. Keep riders off.
  - Riders also obstruct the operator's view, resulting in the machine being operated in an unsafe manner.
  - If there are riders, do not allow riders other than on the trainer's seat. Riders should also have their seat belt fastened.

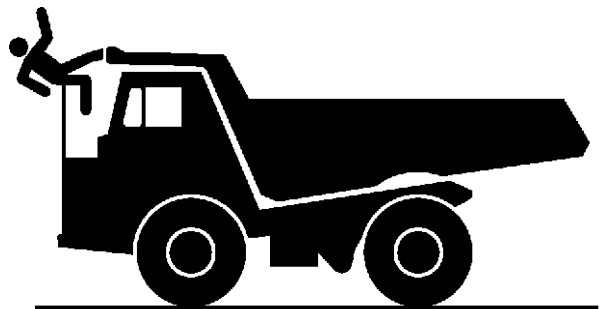

SA-1600

## SAFETY

---

### Avoid Injury Caused by High Tension Electric Shock

- Never attempt to open any electrical component covers displaying a decal with the words "HIGH VOLTAGE." You may receive an electric shock, possibly resulting in personal injury or death.
- Never attempt to touch or grab any high tension electrical components or the power cable with wet hands. You may receive an electric shock, possibly resulting in personal injury or death.



SA-112

---

### Investigate Job Site Beforehand

- When working on a road shoulder, the machine could tip over, possibly resulting in serious injury or death.
- Investigate the configuration and ground conditions of the job site beforehand to prevent the machine from falling and to prevent the ground, stockpiles, or banks from collapsing.
- Make a work plan. Use machines appropriate to the work and job site.
- Reinforce ground, edges, and road shoulders as necessary. Keep the machine well back from the edges of excavations and road shoulders.
- When working on an incline or on a road shoulder, employ a signal person as required.
- When the footing is weak, reinforce the ground before starting work.
- When working on frozen ground, be extremely alert. As ambient temperatures rise, footing becomes loose and slippery.
- Beware the possibility of fire when operating the machine near flammable objects such as dry grass.
- Driver should try to travel the road once to understand potential danger.



SA-1601

---

### Provide Signals for Jobs Involving Multiple Machines

- For jobs involving multiple machines, provide signals commonly known by all personnel involved. Also, appoint a signal person to coordinate the job site. Make sure that all personnel obey the signal person's directions.



SA-481

## SAFETY

### Drive Machine Safely

- Before driving the machine, always confirm that the shift lever direction corresponds to the direction you wish to drive.
  - Be sure to detour around any obstructions.
  - Avoid traveling over obstructions. Soil, fragments of rocks, and/or metal pieces may scatter around the machine. Do not allow personnel to stay around the machine while traveling.
  - If the engine stops while driving, the steering function becomes inoperative. Immediately stop the machine by applying the service brake to prevent personal accident.
  - Do not inertia run with the shift lever in Neutral position. Because engine speed is in the slow idling state, the cooling capability of the travel reduction gear reduces. The brake unit may be seriously damaged if the machine continues to drive with the shift lever in Neutral position.
  
- Driving on a slope may cause the machine to slip or overturn, possibly resulting in serious injury or death.
  - Driving across the face of a slope or steering on a slope may cause the machine to skid or overturn. If the direction must be changed, move the machine to level ground, then, change the direction to ensure safe operation.
  
- The “Retarder Decal” is provided in the cab as a general guideline for proper downgrade operation of the loaded machine. Warning, understand downhill speed operation thoroughly before operation. Machine road speed is reduced during downhill operation. When retarder brake operation with overloaded machine on the steep downgrade continues for more than 2 minutes continuously, grid box resistance will be electrical overload. Pay attention that retarder brake torque reduces.
  - Overloaded machine reduces the retarder brake performance. Observe strictly the Hitachi loading policy while driving.
  - Before descending on a slope, decelerate the machine sufficiently using retarder brake.
  - When descending on a slope, drive the machine slowly using retarder brake.
  
- Driving on a rough road may cause the machine to slip or overturn, possibly resulting in serious injury or death.
  - When driving on a rough road or soft ground, reduce speed sufficiently.
  - Driving on a wet road may cause the machine to slip, possibly resulting in serious injury or death. Avoid applying the retarder brake for quick stops.

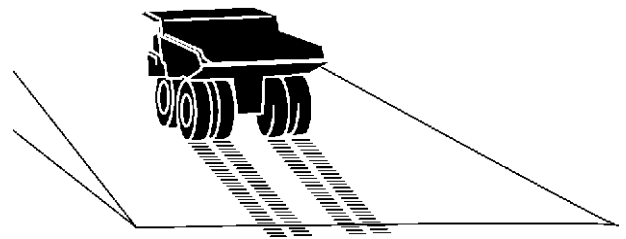

SA-1602

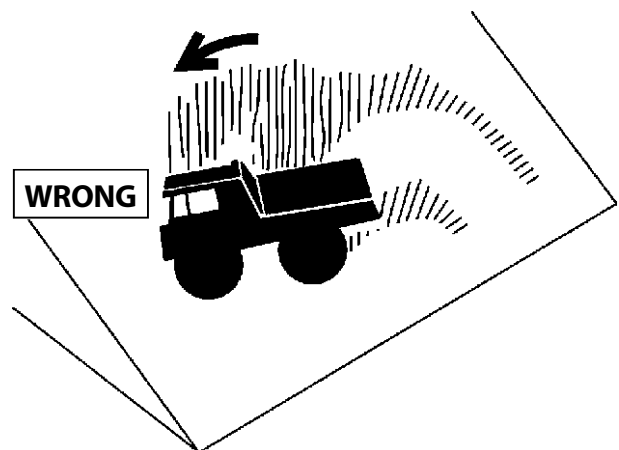

SA-1603

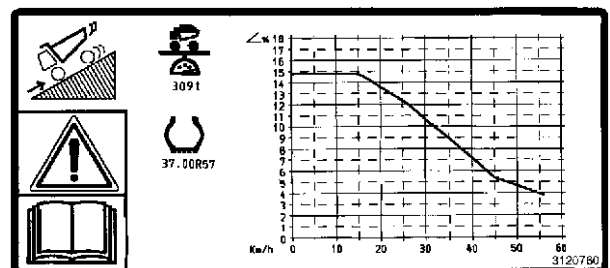

SS3120760

## SAFETY

### Wheel Maintenance

- Mishandling of a tire and rim parts can cause serious injury or death.
- Inspect tires and wheels daily. Do not operate with low pressure, cuts, bubbles, damaged rims, or missing lug bolts and nuts.
- When inflating tires, use a clip-on chuck and extension hose long enough to allow you to stand to one side and not in front of or over the tire assembly. Use a safety cage if available.
- Do not attempt to inflate or mount a tire unless you have the proper equipment and experience to perform the job. Have it done by your authorized dealer or a qualified repair service.
- Always maintain the correct tire pressure. DO NOT inflate tire above the recommended pressure.
- Explosions of air inflated tires have resulted from heat-induced gas combustion inside the tires. Explosions can be caused by heat that is generated by welding, by heating rim components, by external fire, or by excessive use of brakes. Explosions differ from punctures or tire bursts because the destructive force is extremely large. This could result in tire explosion which could propel projectiles in excess of 500 m (1640 ft) from the machine. Both the force of the explosion and the flying debris can cause property damage, personal injury, or death. If tire overheating is suspected or noticed, do not approach the tire within any area included in the shaded area (15 m in radius) in the illustration and restrict access underneath the truck, until the tire has cooled down sufficiently.
- Store tires safely.
- Store tires in the place where tires are not exposed to the direct sunlight, rain, water and oil. Avoid near external heat source or electric sparks hazard.
- Stand tire on level ground, and block it securely so that it cannot roll or fall over.
- Store the tires in a warehouse in which unauthorized persons cannot enter. If the tires are stored outside, always erect a fence around the tires and put up "No Entry" and other warning signs that even young children can understand.

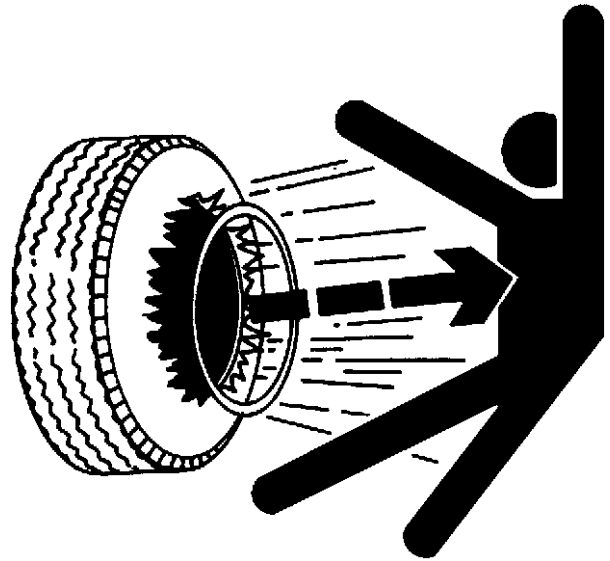

SA-249

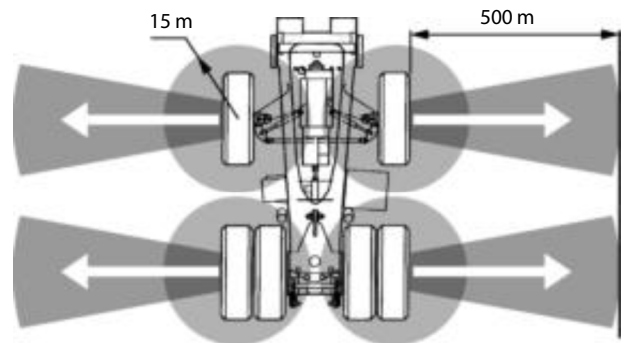

SA-2298

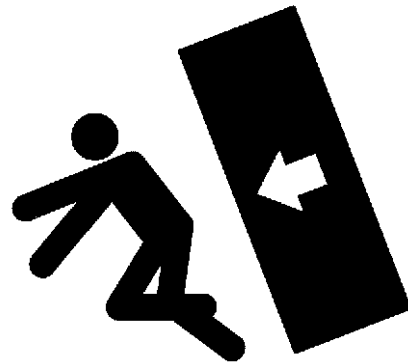

SA-034

## SAFETY

### Drive on Snow Safely

- Beware of the possibility of slipping or overturning the machine when traveling on frozen snow surfaces.
- The machine may slip more easily than expected on frozen snow surfaces even if the inclination is small. Reduce speed when driving. Avoid fast starts, stops and quick turns.
- Road shoulder and/or set-up utilities covered with snow are difficult to locate. Be sure where they are before removing snow.
- Avoid applying the brake for quick stops on snow.

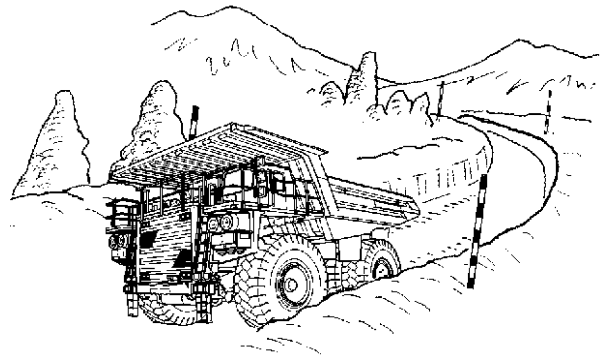

SA-1578

### Avoid Injury from Rollaway Accidents

- Death or serious injury may result if you attempt to mount or stop a moving machine.

To avoid rollaways:

1. Select level ground when possible to park the machine.
2. Do not park the machine on a grade.
3. Lower the dump body to the frame rail.
4. Place the shift lever in the Neutral position and switch the parking brake switch ON.
5. Run the engine at slow idle speed without load for 5 minutes to cool down the engine.
6. Stop the engine and remove the key from the key switch.
7. Chock the wheels if you must park on a grade.
8. Position the machine to prevent rolling.
9. Park at a reasonable distance from other machines.

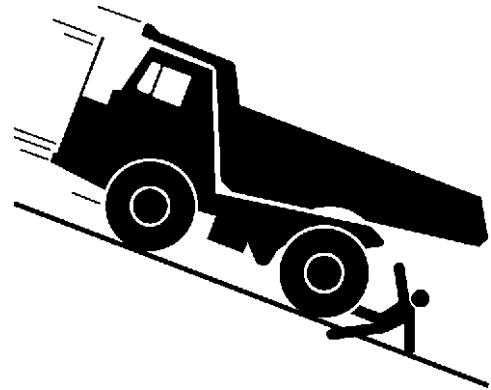

SA-1579

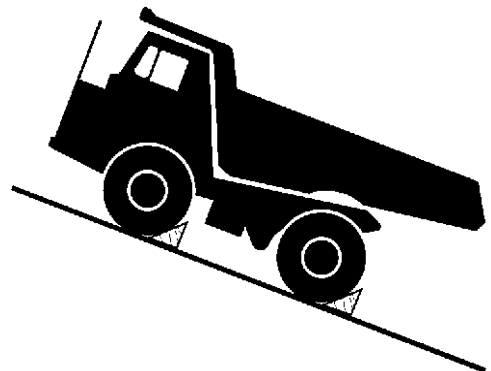

SA-1580



**Suggest:**

**For more complete manuals. Please go to the home page.**

**<https://www.ebooklibonline.com>**

**If the above button click is invalid. Please download this document first, and then click the above link to download the complete manual.**

**Thank you so much for reading**

## SAFETY

---

### Avoid Injury from Back-Over Accidents

- If any person is present near the machine when backing the machine, the machine may hit or run over that person, resulting in serious injury or death.

To avoid back-over accidents:

- Always look around BEFORE YOU BACK UP THE MACHINE. BE SURE THAT ALL BYSTANDERS ARE CLEAR.
- Keep the travel alarm in working condition (if equipped). ALWAYS BE ALERT FOR BYSTANDERS MOVING INTO THE WORK AREA. USE THE HORN OR OTHER SIGNAL TO WARN BYSTANDERS BEFORE MOVING MACHINE.
- USE A SIGNAL PERSON WHEN BACKING UP IF YOUR VIEW IS OBSTRUCTED. ALWAYS KEEP THE SIGNAL PERSON IN VIEW.
- Use hand signals, which conform to your local regulations, when work conditions require a signal person.
- No machine motions shall be made unless signals are clearly understood by both signal person and operator.
- Learn the meanings of all flags, signs, and markings used on the job and confirm who has the responsibility for signaling.
- Keep windows, mirrors, and lights clean and in good condition.
- Dust, heavy rain, fog, etc., can reduce visibility. As visibility decreases, reduce speed and use proper lighting.
- Read and understand all operating instructions in the operator's manual.

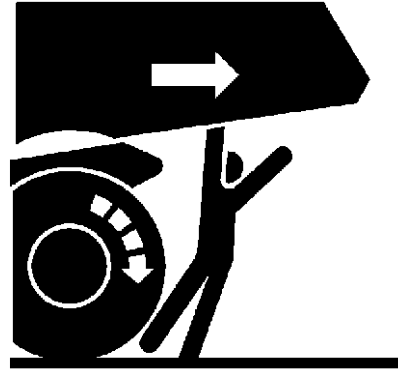

SA-1581



SA-1582

---

### Keep Person Clear from Working Area

- A person may be hit severely by the machine and/or may be crushed against another object, resulting in serious injury or death.
- Keep all persons clear from the area of operation and machine movement.
- Before operating the machine, set up barriers to the sides and rear area of the working area to prevent anyone from entering the work area.

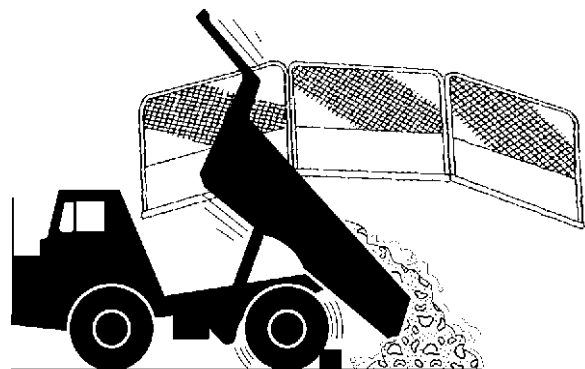

SA-1583

## SAFETY

---

### Avoid Tipping

**DO NOT ATTEMPT TO JUMP CLEAR OF TIPPING MACHINE  
--- SERIOUS OR FATAL CRUSHING INJURIES WILL RESULT  
MACHINE WILL TIP OVER FASTER THAN YOU CAN JUMP  
FREE**

**THEREFORE, HOLD FIRMLY ONTO THE STEERING WHEEL IF  
THE MACHINE SHOULD TIP OR ROLL OVER. DO NOT JUMP.**

#### **FASTEN YOUR SEAT BELT**

- The cab is designed for the protection of the operator and it meets the requirements for Roll-Over Protection Structures (ROPS) according to the adopted standard for this machine.

**IMPORTANT:**

- **Never make any unauthorized modifications or alterations to the Roll-Over Protective Structures (ROPS) such as; welding on fire extinguisher brackets, CB antenna brackets, or fire suppression systems. Such unauthorized modifications will affect the structural limits of the ROPS and will void the certification and could result in loss of protection to the operator.**
- **Do not convert Hauler into Water Truck. (This cab has not been certified to meet specified requirements according to ISO 3471 Tractor.)**

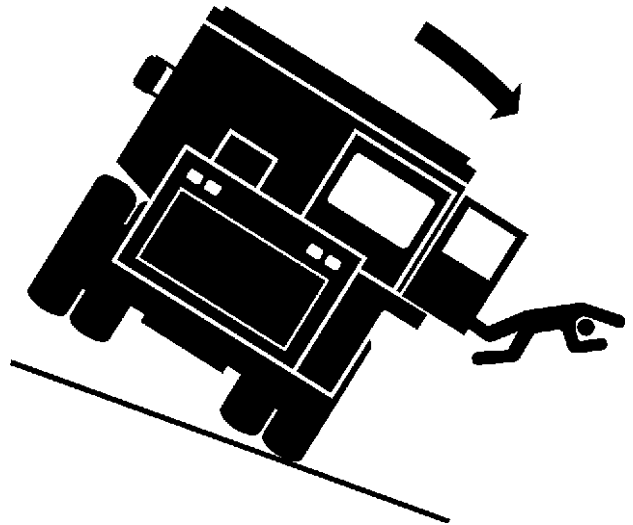

SA-1584

The Roll-Over Protective Structures (ROPS) has been certified to meet specified requirements according to ISO 3471 Hauler.

- The danger of tipping is always present when operating on a grade, possibly resulting in serious injury or death.

To avoid tipping:

- Be extra careful before operating on a grade.
  - Keep the machine at a safe distance from the edge of cliffs and slide areas.
  - Reduce operating speeds to avoid tipping or slipping.
  - Avoid changing direction when driving on grades.
  - Use the seat belt during operation.
  - When operating the machine, both doors should be closed at all times.
- Be careful when working on frozen ground.
  - Temperature increases will cause the ground to become soft and make ground travel unstable.

**<https://www.ebooklibonline.com>**

Hello dear friend!

Thank you very much for reading.

Enter the link into your browser.

The full manual is available for immediate download.

**<https://www.ebooklibonline.com>**