

Product: COMPACT WHEEL LOADER

Model: 910M COMPACT WHEEL LOADER H22

Configuration: 910M Compact Wheel Loader H2200001-UP (MACHINE) POWERED BY C4.4 Engine

Disassembly and Assembly 910M, 914M and 918M Wheel Loader Power Train

Media Number -M0070750-01

Publication Date -01/09/2018

Date Updated -26/09/2018

i05972344

Transmission - Disassemble

SMCS - 3002-015; 3030-015; 3150-015; 3159-015

S/N - H221-UP

S/N - H241-UP

S/N - H261-UP

Disassembly Procedure

Table 1

Required Tools			
Tool	Part Number	Part Description	Qty
A	242-9955	2 Jaw Puller	1
B	1P-0510	Driver Gp	1
C	421-5663	Lifting Eye Assembly	1
D	1P-2322	Combination Puller	1
E	5F-7343	Bearing Puller Gp	1
F	421-5661	Lifting Eye Assembly	1

Start By:

- A. Remove the transmission.

NOTICE

Care must be taken to ensure that fluids are contained during performance of inspection, maintenance, testing, adjusting, and repair of the product. Be prepared to collect the fluid with suitable containers before opening any compartment or disassembling any component containing fluids.

Refer to Special Publication, NENG2500, "Dealer Service Tool Catalog" for tools and supplies suitable to collect and contain fluids on Cat products.

Dispose of all fluids according to local regulations and mandates.

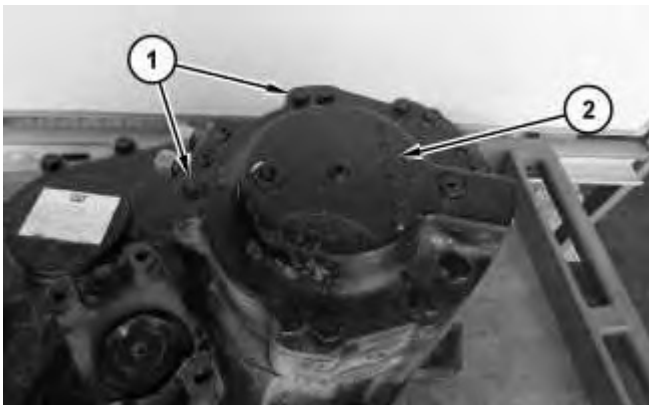
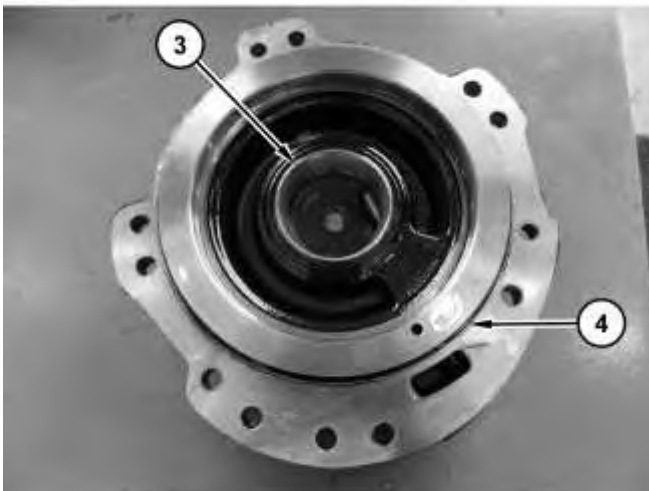

Illustration 1

g03681137

1. Remove bolts (1) and cover (2).



2. Remove bearing cup (3) and O-ring seal (4) .

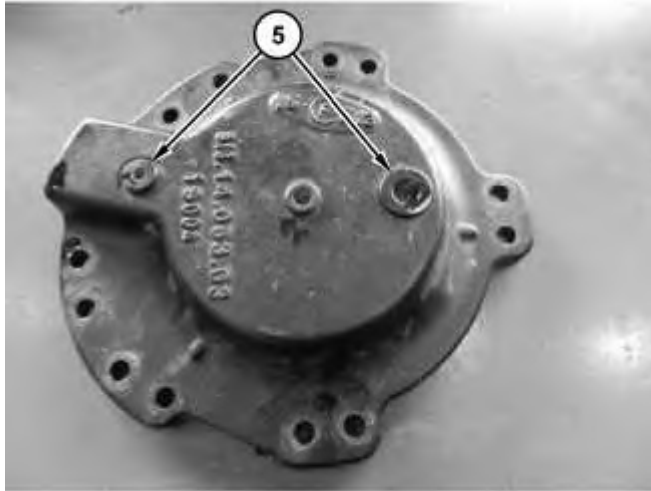

Illustration 3

3. Remove plugs (5) and the O-ring seals.

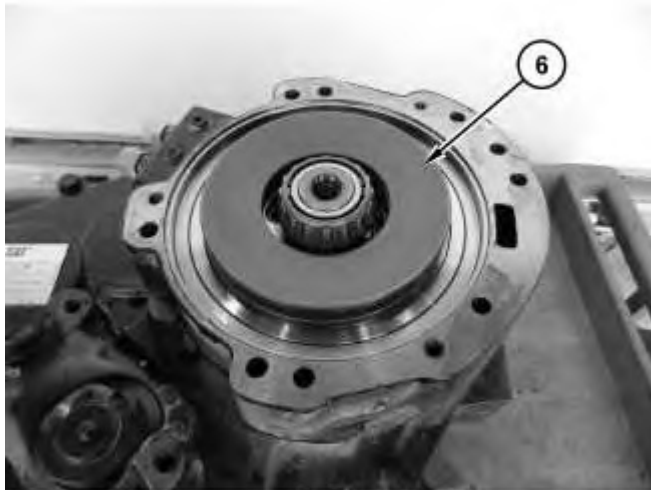

Illustration 4

4. Remove Belleville washers (6) .

<https://www.ebooklibonline.com>

Hello dear friend!

Thank you very much for reading.

Enter the link into your browser.

The full manual is available for immediate download.

<https://www.ebooklibonline.com>

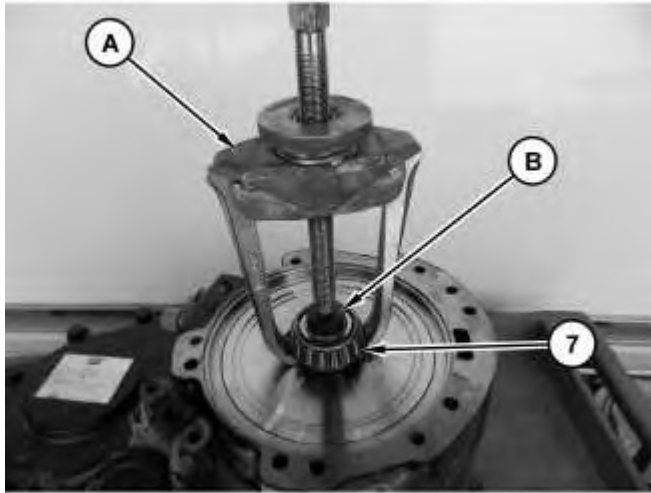

Illustration 5

g03681173

5. Use Tooling (A) and Tooling (B) to remove bearing cone (7) .



Illustration 6

g03681339

6. Remove clutch housing adapter (8) .
-

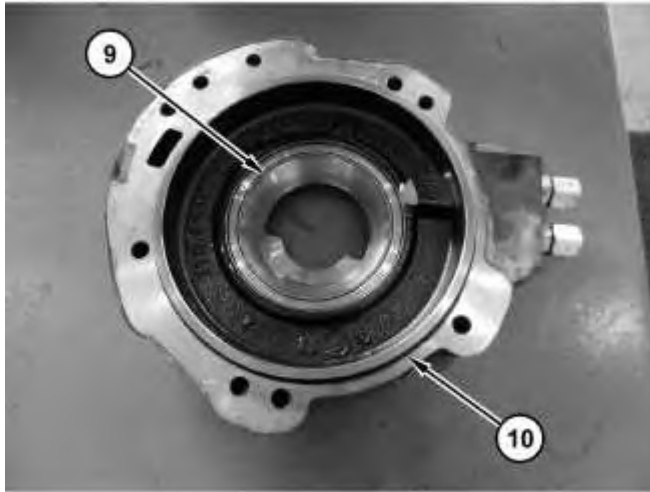

Illustration 7

g03681342

7. Remove bearing cup (9) and O-ring seal (10).

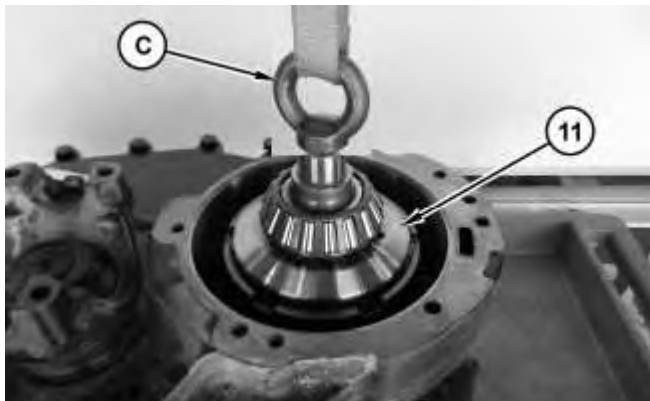

Illustration 8

g03681347

8. Use Tooling (C) and a suitable strap to remove clutch shaft (11) .
-

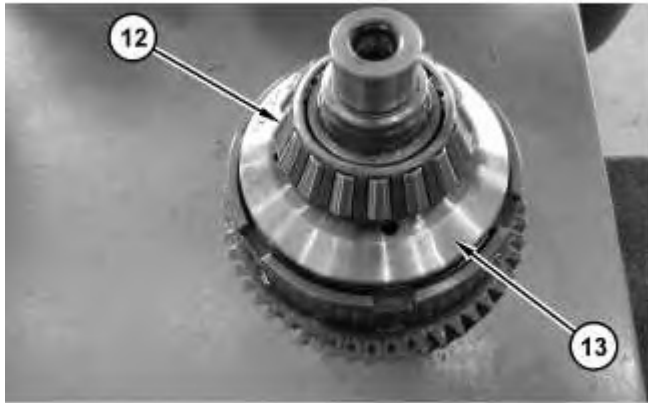

Illustration 9

g03681385

9. Remove bearing cone (12) and pressure plate (13) .

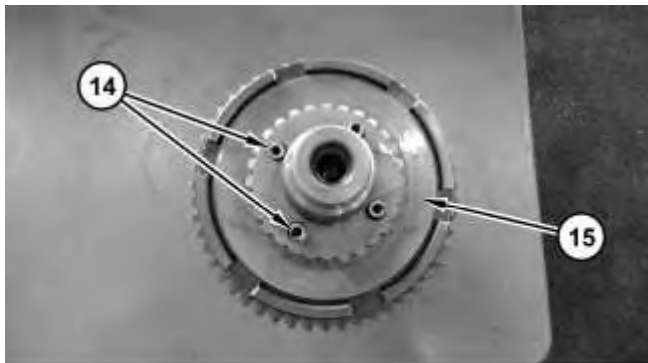

Illustration 10

g03681391

10. Remove springs (14) and clutch discs (15) .

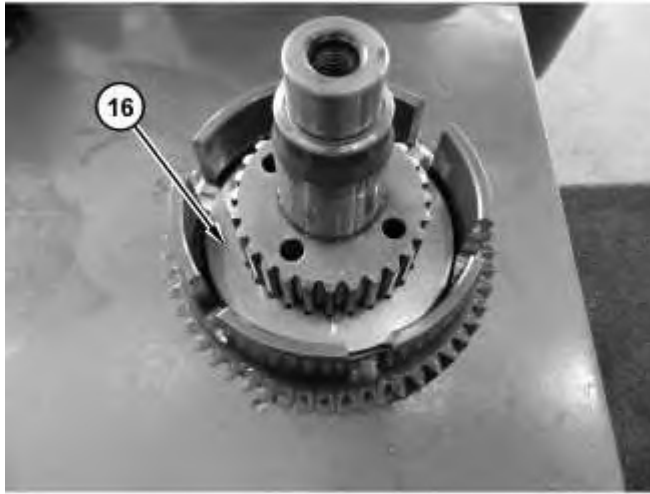

Illustration 11

g03681397

11. Remove driven disc (16) .



Illustration 12

g03681443

12. Remove retaining ring (17) .

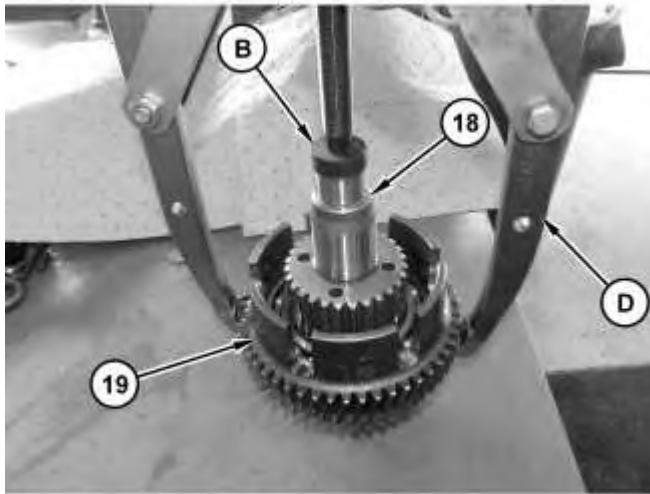

Illustration 13

g03681447

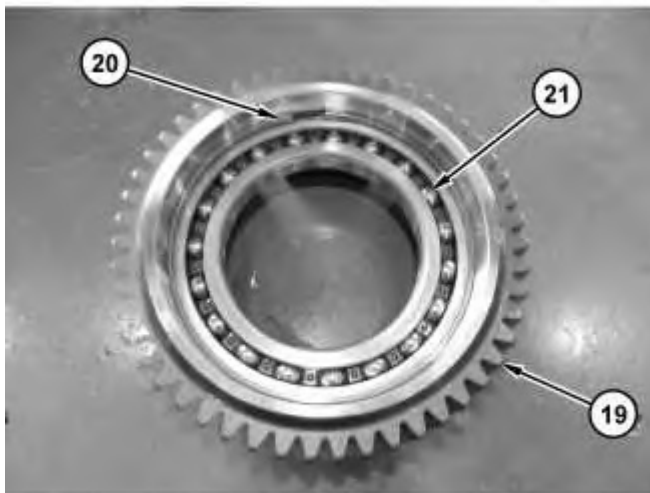

Illustration 14

g03681814

13. Use Tooling (B) and Tooling (D) to remove clutch sleeve (19) from clutch shaft (18) .
 14. Remove retaining ring (20) and bearing (21) from clutch sleeve (19) .
-

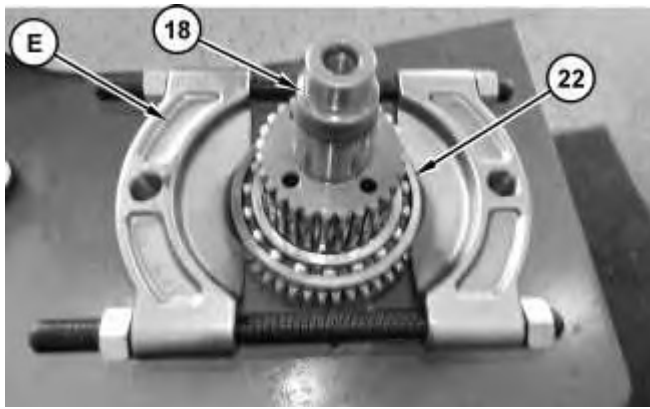

Illustration 15

g03681836

15. Use Tooling (E) to remove bearing (22) from clutch shaft (18) .

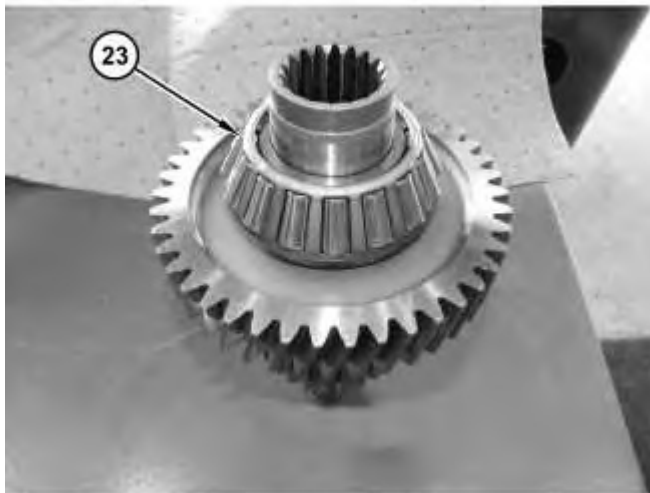

Illustration 16

g03681971

16. Remove bearing cone (23) .

Note: This step is a destructive procedure.

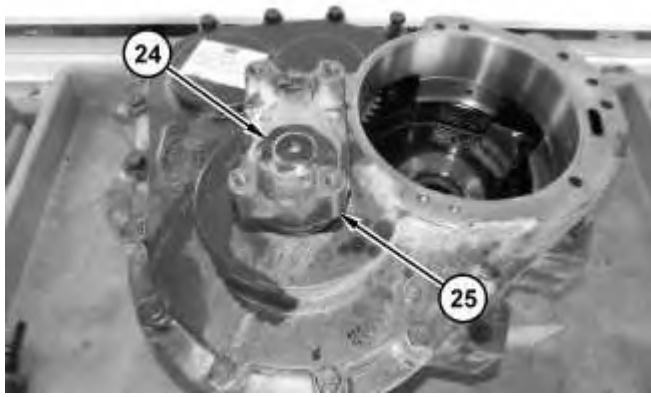

Illustration 17

g03682176

17. Remove nut (24) and yoke (25) .

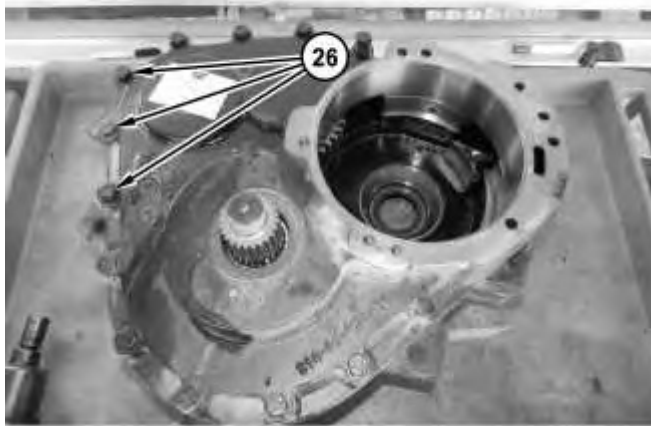

Illustration 18

g03682182

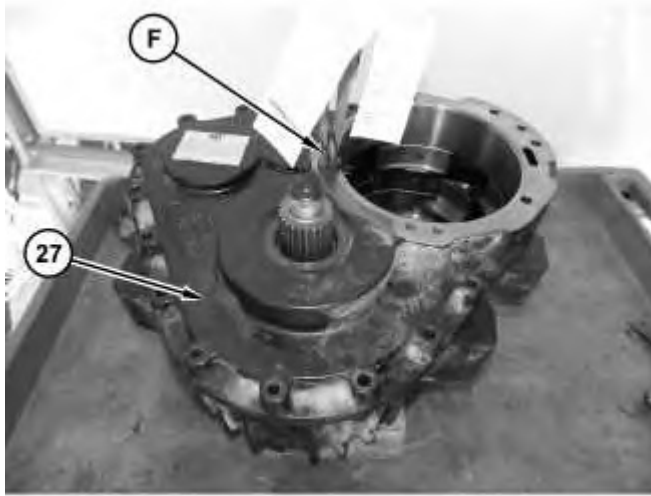

Illustration 19

g03682323

18. Remove bolts (26). Use Tooling (F) and a suitable lifting device to remove cover (27). The weight of cover (27) is approximately 23 kg (50 lb).



Illustration 20

g03682218

19. Remove bearing cup (28) and lip seal (29) .
-

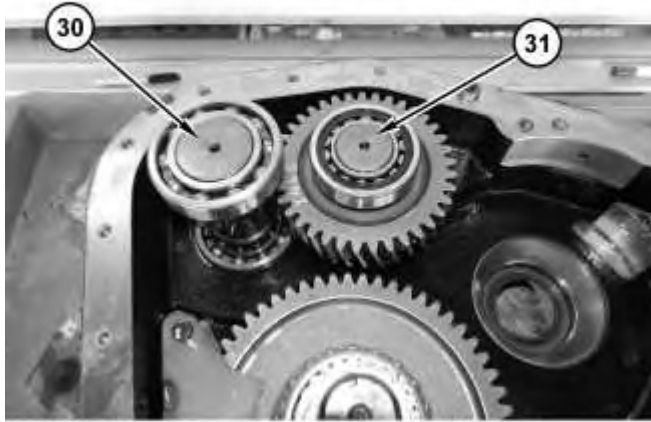

Illustration 21

g03682223

20. Remove upper shaft (30) and idler shaft (31) .

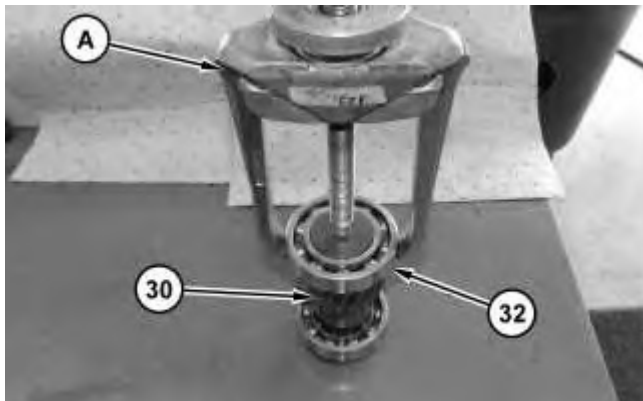

Illustration 22

g03682256

21. Use Tooling (A) to remove bearing (32) from upper shaft (30). Repeat for opposite side.
-

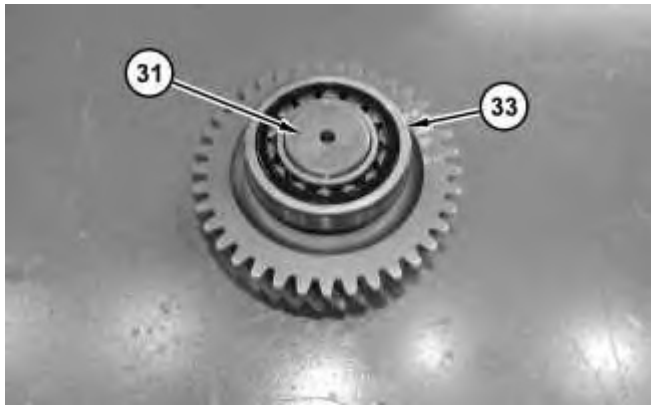

Illustration 23

g03682270

22. Remove bearing (33) from idler shaft (31) .

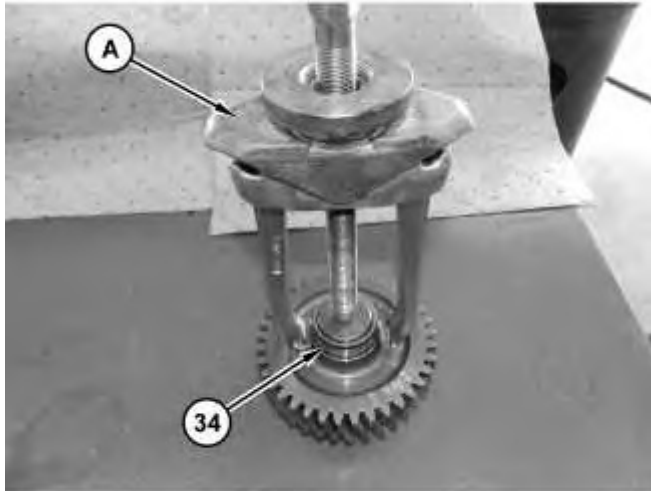

Illustration 24

g03682278

23. Remove bearing inner race (34). Repeat for opposite side.

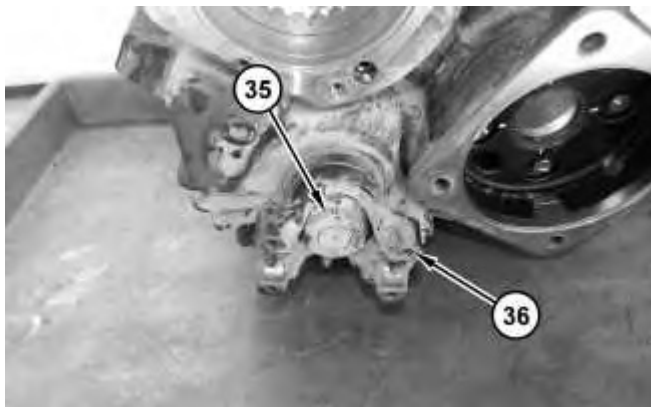

Illustration 25

g03682281

24. Remove nut (35) and yoke (36) .

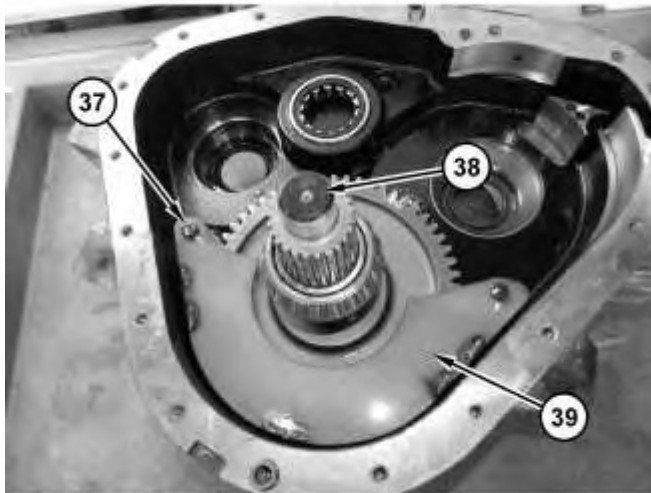

Illustration 26

g03682284

25. Remove bolts (37), lower shaft (38), and baffle plate (39) .

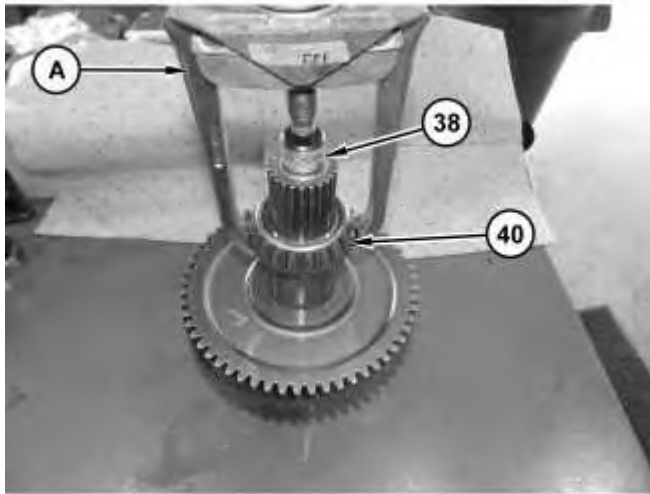

Illustration 27

g03682288

26. Use Tooling (A) to remove bearing (40) from lower shaft (38) .

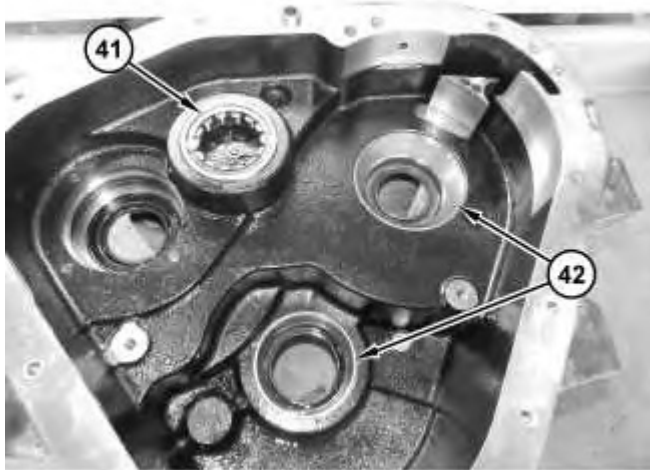

Illustration 28

g03682294

27. Remove bearing (41) and bearing cups (42) .
-

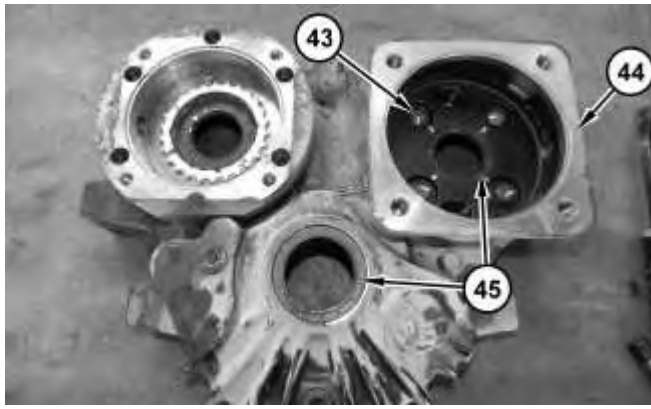

Illustration 29

g03682302

28. Remove lip seals (45). Remove bolts (43) and flange (44) .

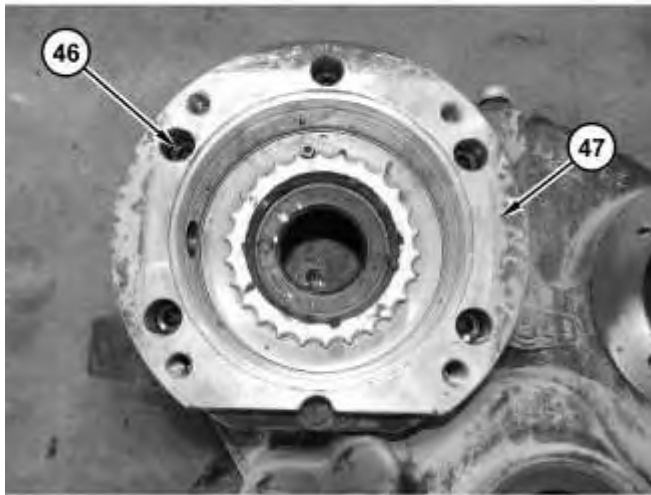

Illustration 30

g03682309

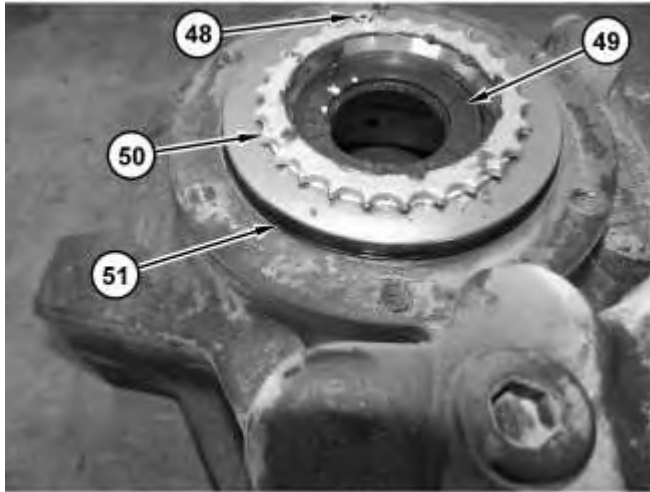

Illustration 31

g03682313

29. Remove bolts (46) and flange (47). Remove lip seal (49). Remove bolt (48), threaded ring (50), and O-ring seal (51) .

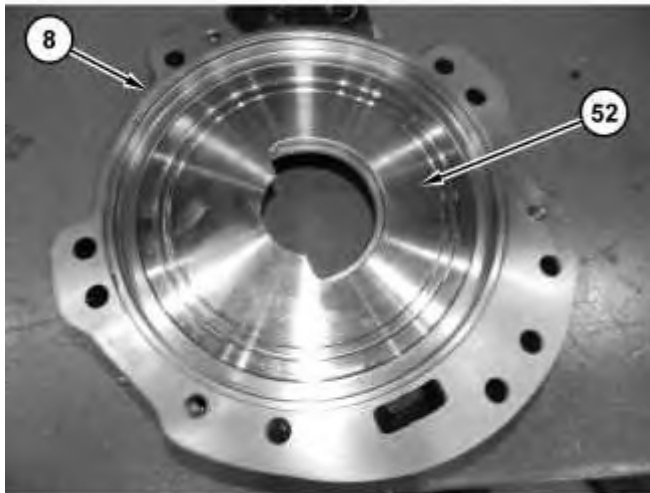

Illustration 32

g03682321

30. Remove piston (52) from clutch housing adapter (8) .
-



Illustration 33

g03682440

31. Remove O-ring seals (53) .

Product: COMPACT WHEEL LOADER

Model: 910M COMPACT WHEEL LOADER H22

Configuration: 910M Compact Wheel Loader H2200001-UP (MACHINE) POWERED BY C4.4 Engine

Disassembly and Assembly 910M, 914M and 918M Wheel Loader Power Train

Media Number -M0070750-01

Publication Date -01/09/2018

Date Updated -26/09/2018

i06782421

Transmission - Assemble

SMCS - 3002-016; 3030-016; 3150-016; 3159-016

S/N - H221-UP

S/N - H241-UP

S/N - H261-UP

Assembly Procedure

Table 1

Required Tools			
Tool	Part Number	Part Description	Qty
C	421-5663	Lifting Eye Assembly	1
F	421-5661	Lifting Eye Assembly	1
G	9S-7354	Torque Wrench Gp	1
H	464-6943	Tool Assembly-Rolling Torque	1
J	-	Loctite 242	-
K	-	Loctite HIFLX GM	-
M	-	Loctite 270	-
P	-	Loctite 572	-
Q	-	M16 X 1.5 X 55mm Bolt	1
	-	10 mm Thick Washer	1

Note: Cleanliness is an important factor. Before assembly, clean all parts thoroughly in cleaning fluid. Allow the parts to air dry. Wiping cloths or rags should not be used to dry parts. Lint may be deposited on the parts which may cause later trouble. Inspect all parts. If any parts are worn or damaged, use new parts for replacement. During assembly, put clean transmission oil on all internal parts.

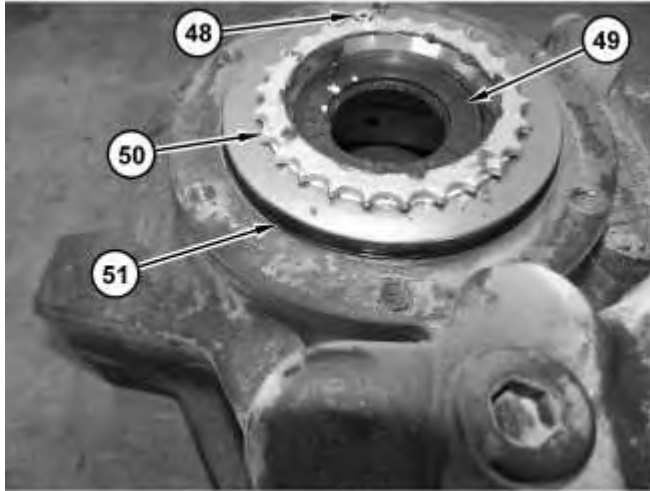
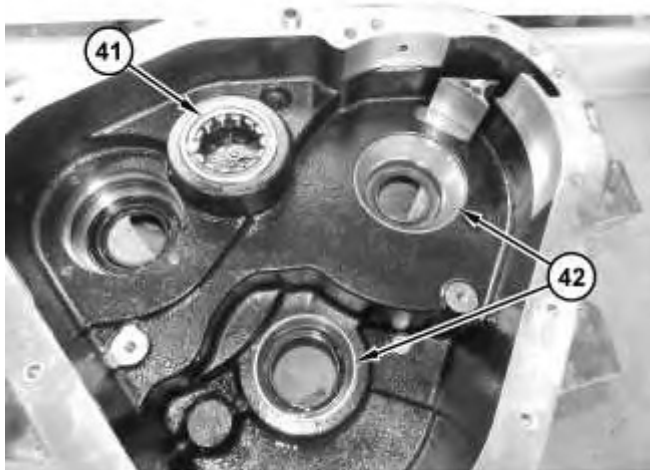

Illustration 1

g03682313

1. Install O-ring seal (51).
2. Install ring nut (50) hand tight.
3. Install bolt (48) and lip seal (49) with the spring facing up. Lubricate the inner edge of the lip seal.



4. Install bearing (41) and bearing cups (42).

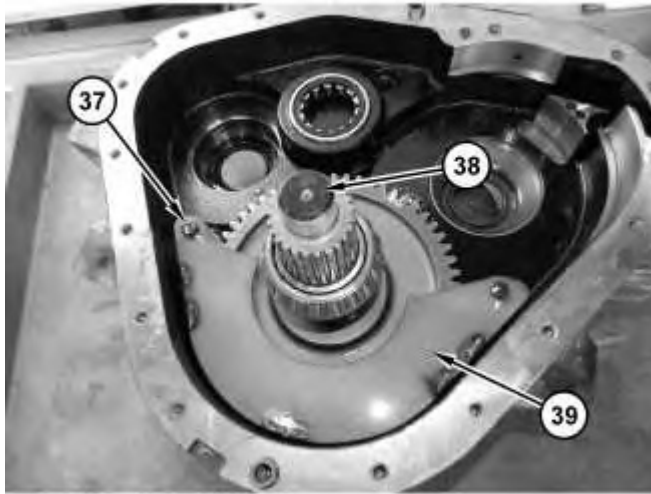

Illustration 3

5. Install lower shaft (38), gear protection cover (39), and bolts (37). Tighten bolts (37) to a torque of $25 \pm 5 \text{ N}\cdot\text{m}$ ($221 \pm 44 \text{ lb in}$).

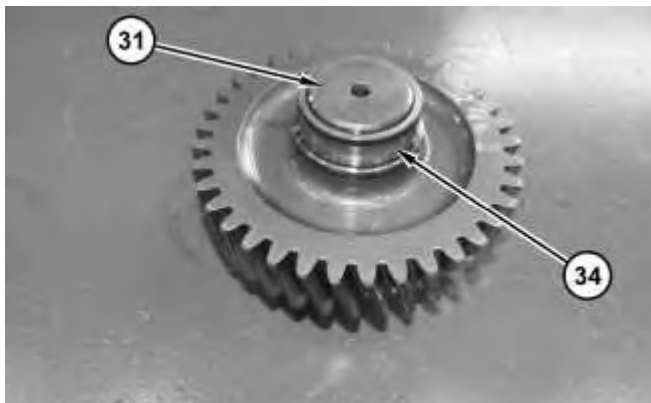

Illustration 4

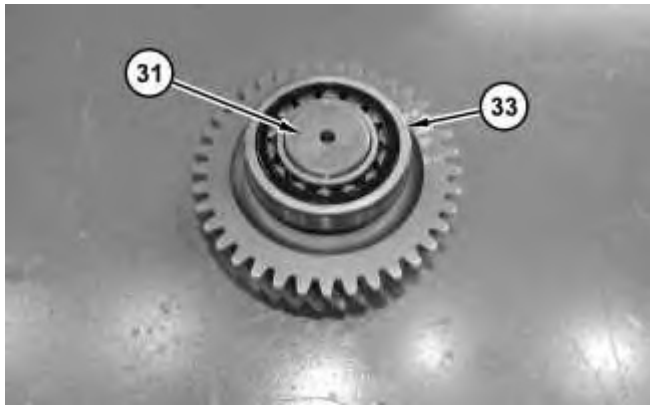

Illustration 5

g03682270

6. Raise the temperature of bearing inner race (34) and install onto idler shaft (31). Repeat for the opposite side. Install bearing (33) onto idler shaft (31).

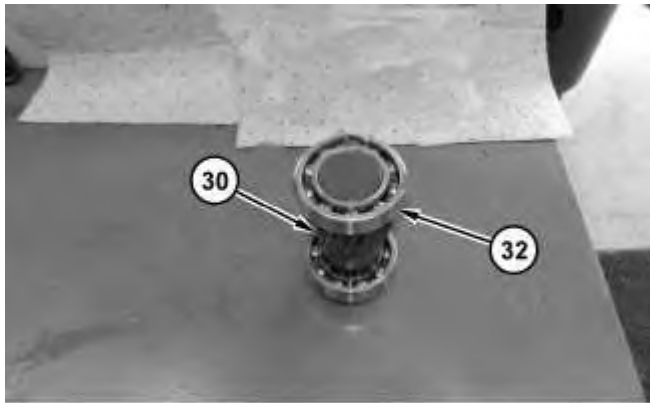

Illustration 6

g03685365

7. Raise the temperature of bearing (32) and install onto upper shaft (30). Repeat for the opposite side.



8. Install idler shaft (31) and upper shaft (30).

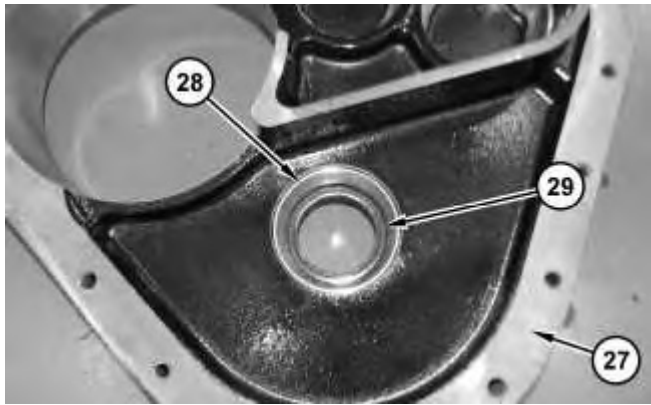

Illustration 8

9. Install lip seal (29) with the spring facing up. Install bearing cup (28) into cover (27).

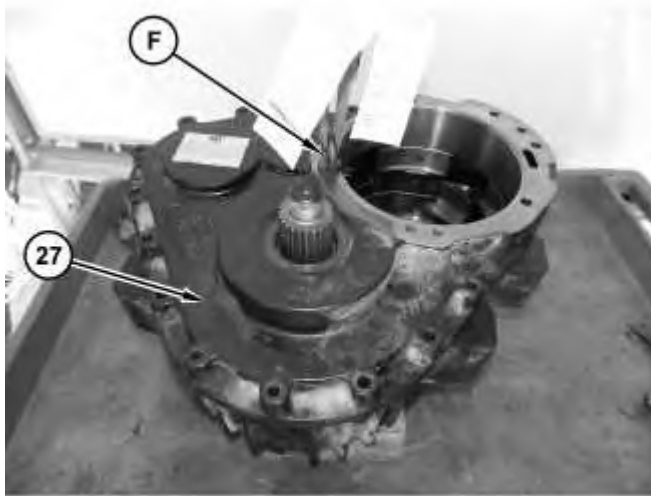

Illustration 9



Illustration 10

g03682182

- Put Tooling (K) on mating surfaces of cover (27). Use Tooling (F) and a suitable lifting device to install cover (27). The weight of cover (27) is approximately 23 kg (50 lb). Install bolts (26). Tighten bolts (26) in a criss-cross pattern and tighten to approximately 50 N·m (37 lb ft).

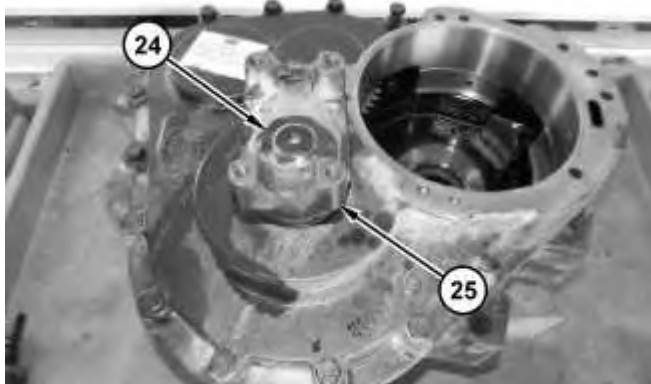

Illustration 11

g03682176

- If removed, grease the inner edge of the lip seal and install.
 - Install yoke assembly (25). Apply Tooling (M) to the thread of nut (24). Install the washer and nut (24) and tighten to a torque of 325 ± 25 N·m (240 ± 18 lb ft).
-

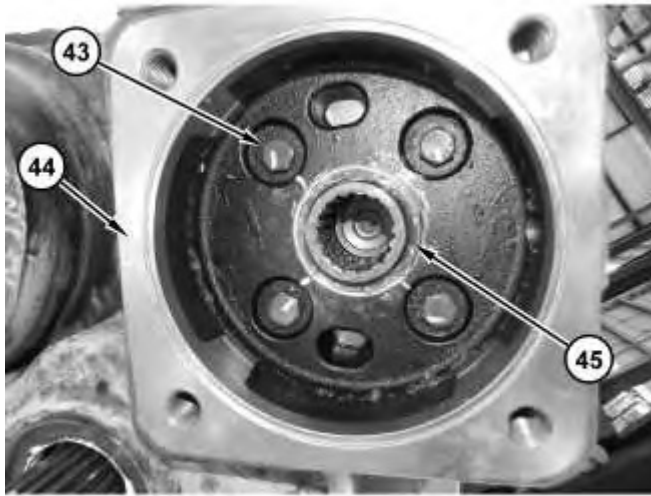

Illustration 12

g03685413

13. Install lip seal (45) with the spring facing in. Install flange (44) and bolts (43). Tighten bolts (43) to a torque of 50 ± 5 N·m (37 ± 4 lb ft).

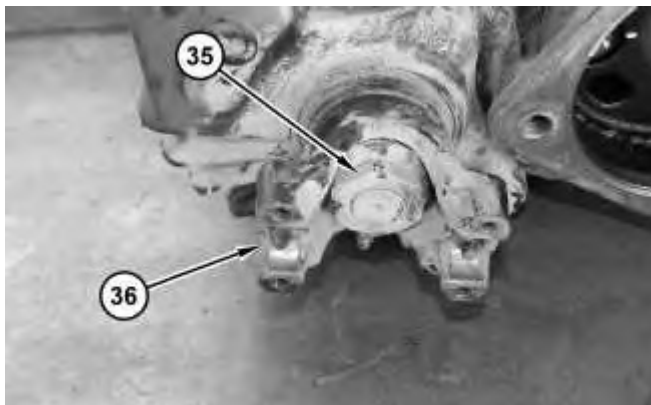

Illustration 13

g03685416

14. If removed, grease the inner edge of the lip seal and install.
15. Install yoke assembly (36). Apply Tooling (M) to the threads of nut (35). Install nut (35) and the O-ring seal and tighten to a torque of 325 ± 25 N·m (240 ± 18 lb ft).

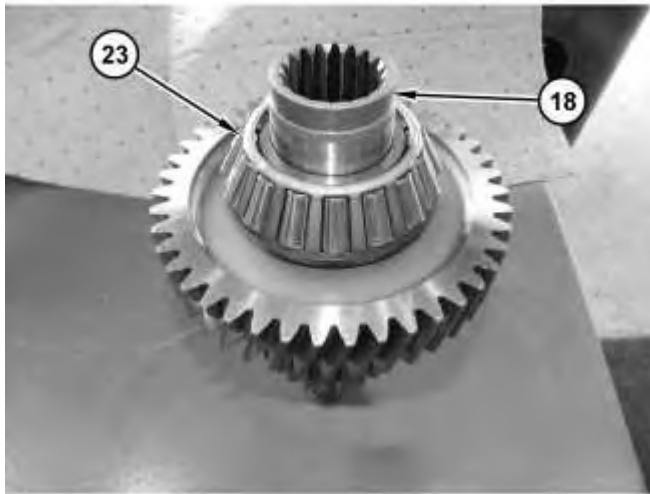

Illustration 14

g03685421

16. Raise the temperature of bearing cone (23) and install onto clutch shaft (18).

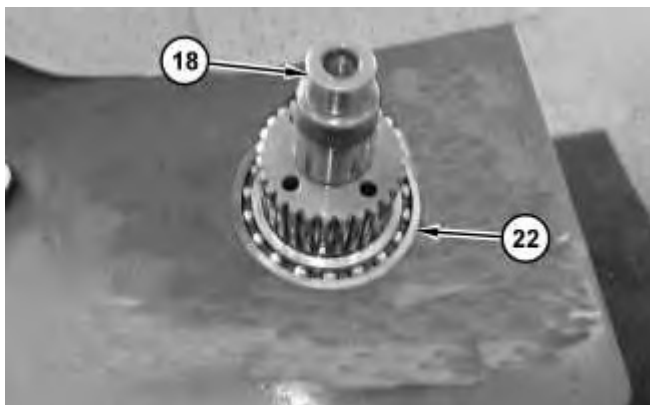

Illustration 15

g03685425

17. Install bearing (22) onto clutch shaft (18).
-

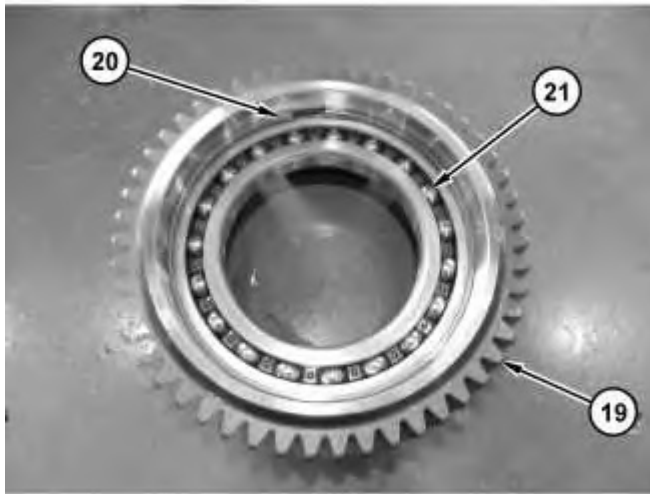

Illustration 16

g03681814

18. Install bearing (21) into clutch sleeve (19). Install retaining ring (20).

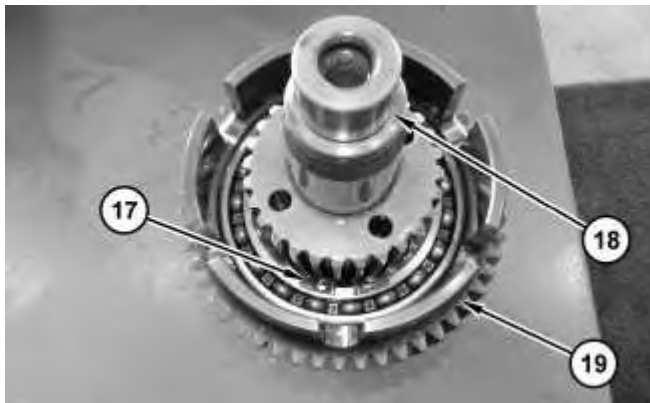

Illustration 17

g03685436

19. Install clutch sleeve (19) onto clutch shaft (18). Install retaining ring (17).
-

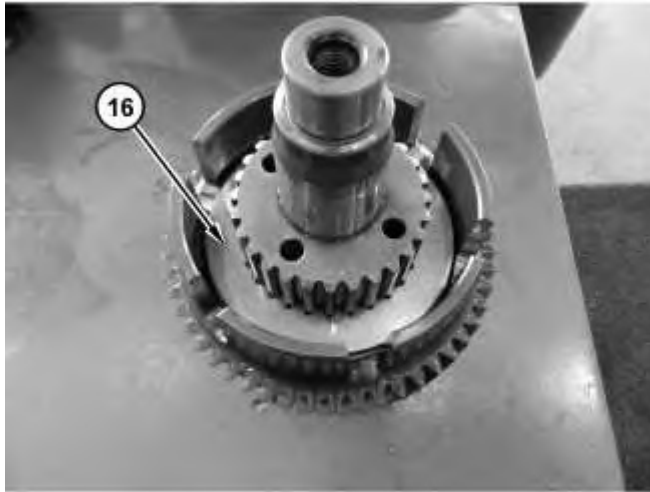

Illustration 18

g03681397

20. Install driven disc (16).



Illustration 19

g03681391

21. Install clutch discs (15) and springs (14).

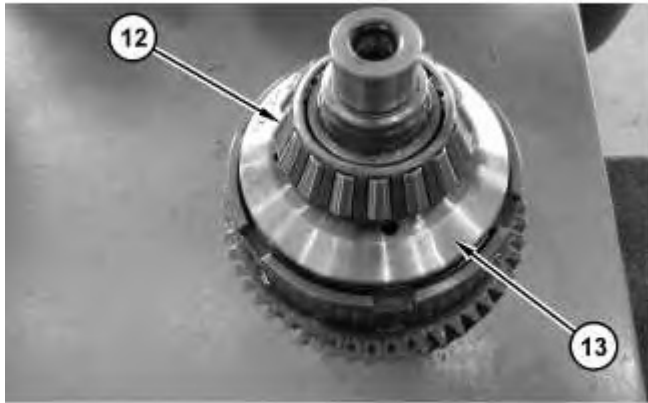

Illustration 20

g03681385

22. Install pressure plate (13) and bearing cone (12).

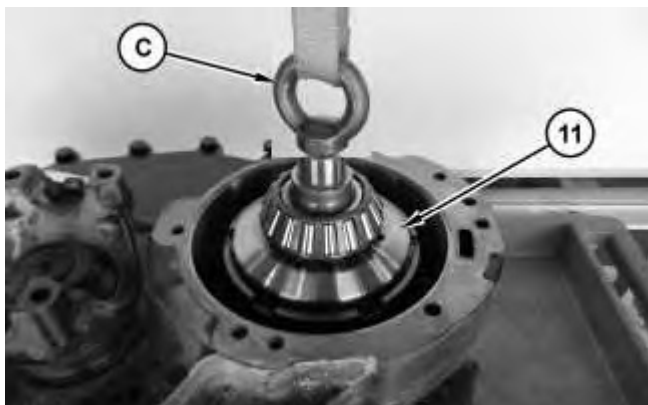

Illustration 21

g03681347

23. Use Tooling (C) and a suitable strap to install clutch shaft (11).
-

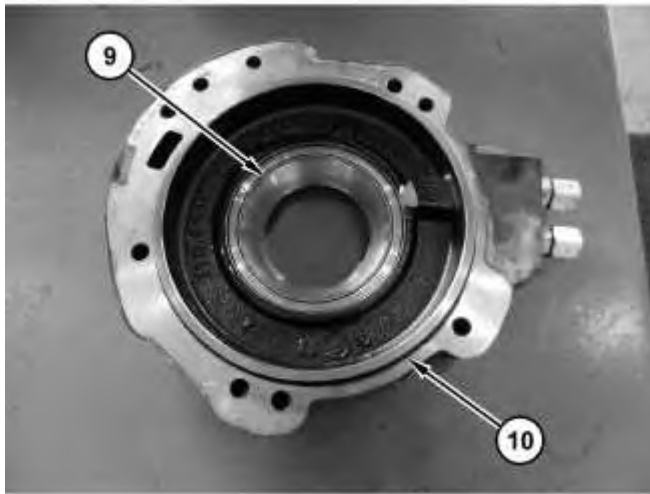

Illustration 22

g03685445

24. Install bearing cup (9) and O-ring seal (10).



Illustration 23

g03682440

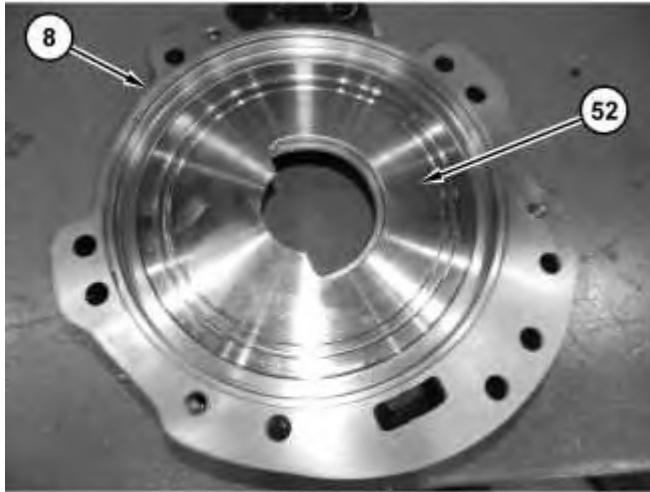

Illustration 24

g03682321

25. Install O-ring seals (53). Install piston (52) into clutch housing adapter (8).



Illustration 25

g03681339

26. Install clutch housing adapter (8).
-



Suggest:

For more complete manuals. Please go to the home page.

<https://www.ebooklibonline.com>

If the above button click is invalid. Please download this document first, and then click the above link to download the complete manual.

Thank you so much for reading

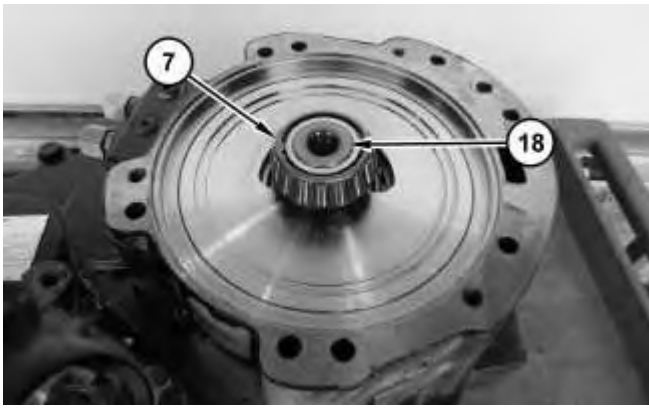

Illustration 26

g03685502

27. Install bearing cone (7) onto clutch shaft (18).

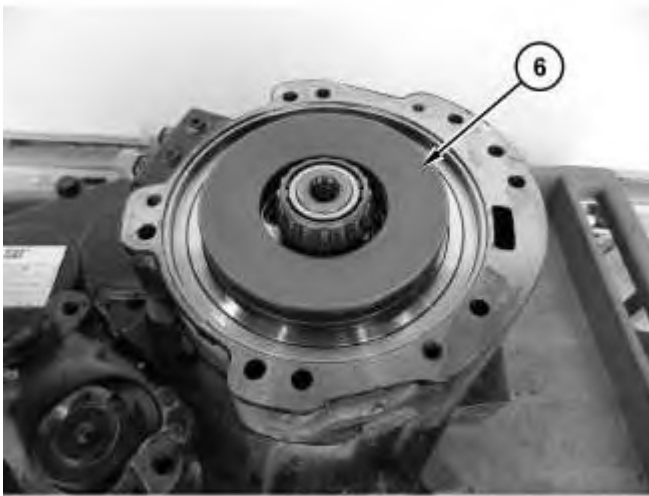
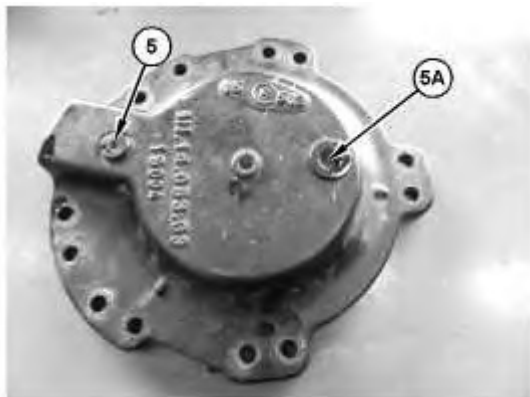

Illustration 27

g03681169

28. Install Belleville washers (6).

Note: Install washers with Beveled edges facing each other.



29. Install plug (5).
 30. Apply Tooling (P) to the threads of plug (5A). Install plug (5A) and tighten to a torque of $42 \pm 7 \text{ N}\cdot\text{m}$ ($372 \pm 62 \text{ lb in}$).
-

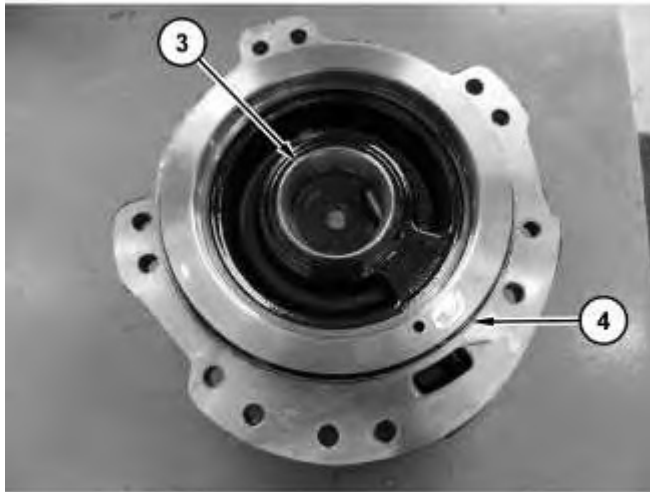

31. Install bearing cup (3) and O-ring seal (4).
-



Typical Example

<https://www.ebooklibonline.com>

Hello dear friend!

Thank you very much for reading.

Enter the link into your browser.

The full manual is available for immediate download.

<https://www.ebooklibonline.com>