

Product: COMPACT WHEEL LOADER

Model: 910 COMPACT WHEEL LOADER 40Y

Configuration: 910 WHEEL LOADER 40Y00001-UP (MACHINE) POWERED BY 3204 ENGINE

Disassembly and Assembly 3204 VEHICULAR ENGINE FOR 910 WHEEL LOADER

Media Number -SEN7985-00

Publication Date -01/01/1980

Date Updated -12/10/2001

Fuel Injection Pump Housing

SMCS - 1253-15; 1253-16

Disassemble Fuel Injection Pump Housing

Tools Needed		A	B	C
8S4613	Wrench	1		
8S2244	Extractor		1	
8S2241	Camshaft Bearing Installation & Removal Tool Group			1

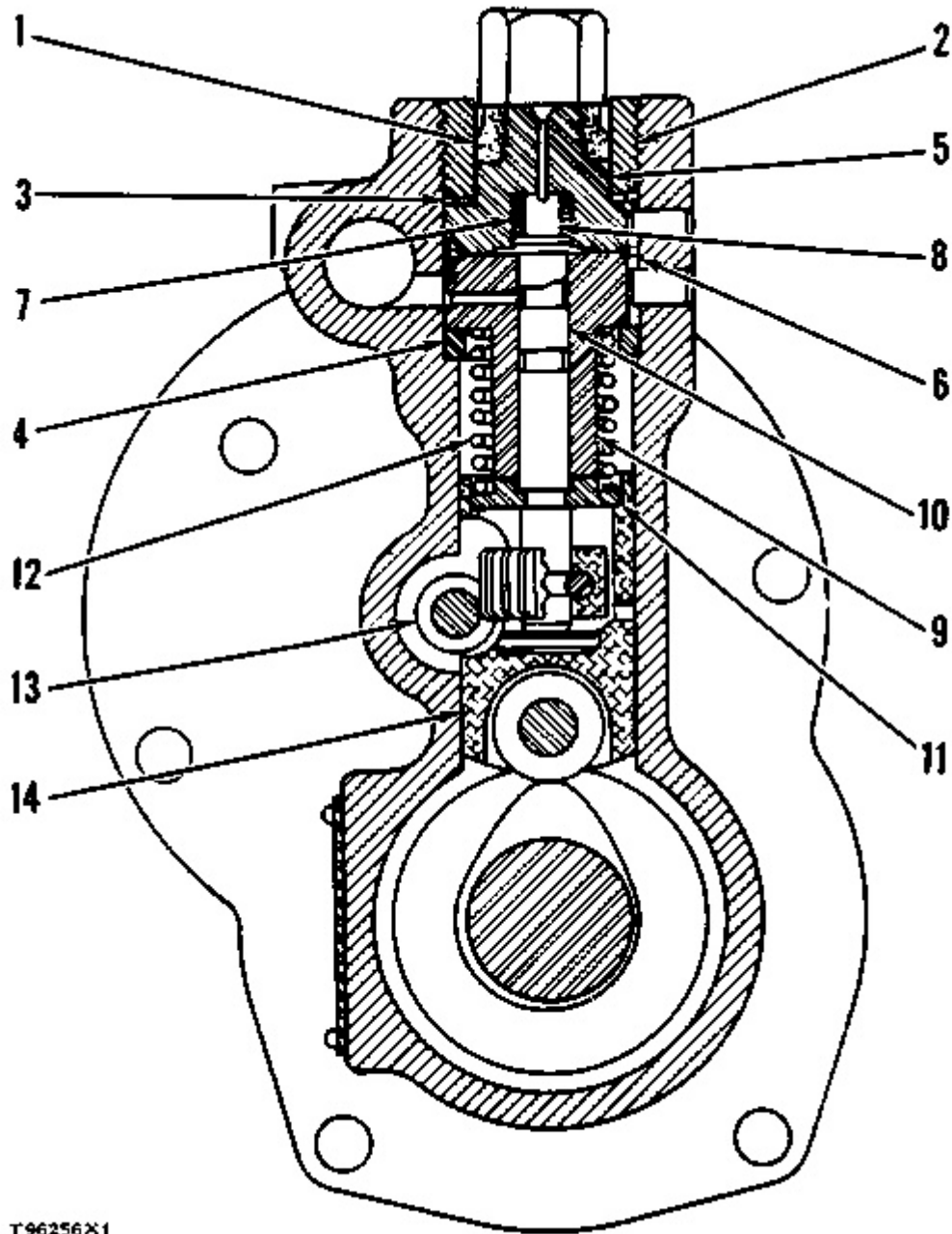

T96256X1

start by:

a) separation of governor from fuel injection pump housing

1. Remove the fuel injection pumps as follows:

a) Remove the protection cap and washer (1).



b) Install tool (A) and remove bushing (2) from housing.

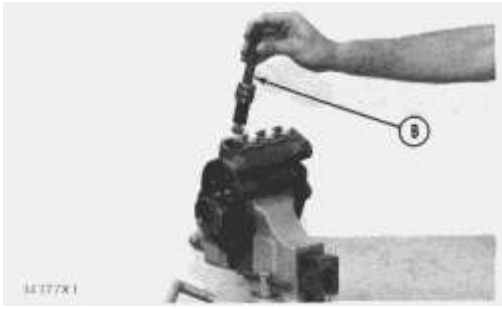

c) Use tool (B) to lift the fuel injection pump out of the housing.

d) Remove spacer (4) from the pump housing.

NOTICE

When injection pumps, spacers and lifters are removed from the injection pump housing, keep the parts of each pump together so they can be installed back in their original location.

2. Disassemble the fuel injection pumps as follows:

a) Remove seal (3) from bonnet (5).

b) Remove ring (6) to make a separation of bonnet (5) from barrel (9).

c) Remove spring (7) and check valve (8) from bonnet (5).

d) Remove the gear segment, plunger (10), washer (11) and spring (12) from barrel (9).

NOTICE

Be careful when the injection pumps are disassembled. Do not cause damage to the surface on the plunger. The plunger and barrel for each pump are made as a set. Do not put the plunger of one pump in the barrel of another pump. If one part has wear, install a complete new pump assembly. Be careful when the plunger is put into the bore of the barrel.

3. Remove rack (13) from the pump housing.

4. Remove lifters (14) from the pump housing.

<https://www.ebooklibonline.com>

Hello dear friend!

Thank you very much for reading.

Enter the link into your browser.

The full manual is available for immediate download.

<https://www.ebooklibonline.com>

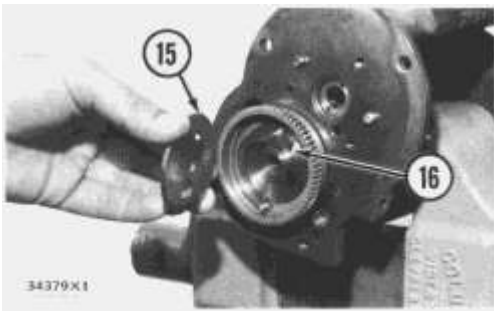

5. Remove the camshaft plate (15), bolt and lock.

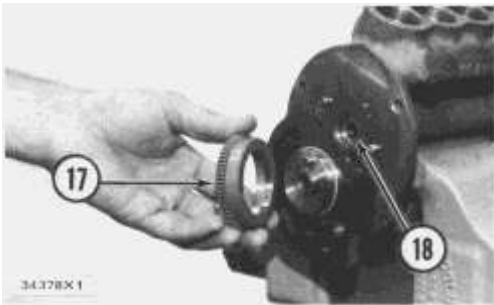

6. Remove spring (16) and gear assembly (17) from the camshaft.

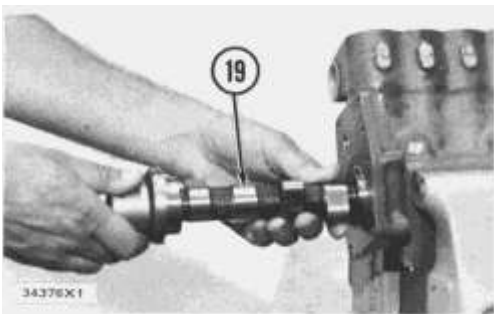

7. Remove camshaft (19) from the pump housing.

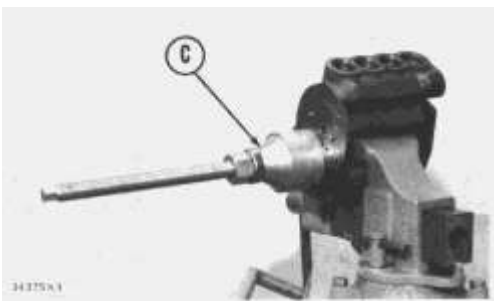

8. Remove the camshaft bearings from the fuel injection pump housing with tool (C).

9. Remove the two bearings (18) from the fuel injection pump housing if necessary.

Assemble Fuel Injection Pump Housing

Tools Needed		A	B	C	D	E	F
8S4613	Wrench	1					
8S2244	Extractor		1				
8S2241	Camshaft Bearing Installation & Removal Tool Group			1			
9S6329	Driver				1		
5P1665	Plate					1	
1B9575	Bolt					1	
1D4716	Nut					1	
7S7113	Rack Setting Gauge						1
FT960	Fuel Injection Pump Installation Tool Group						1
1P510	Driver Group						1

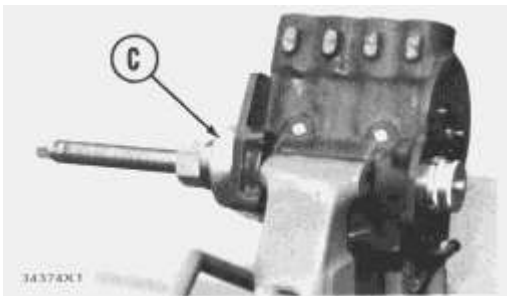

1. Install the camshaft bearings in the fuel injection pump housing with tool (C). Install the bearing in governor end of housing so the lubrication hole in the bearing is in alignment with lubrication hole in housing. Install the camshaft bearings even with outside ends of fuel injection pump housing.

NOTICE

Install the rack bearing in the governor end of the housing with the small holes in the bearing parallel to the vertical centerline of the pump.

2. Install the rack bearing in the governor end of the housing with tooling (F). Install the bearing so it will be $.195 \pm .005$ in. (4.95 ± 0.13 mm) lower than the face of the housing.

NOTICE

Tooling (D) must be used to install the rack bearing in the accessory drive end of the housing. This will put the tab on the bearing in its correct position and install the bearing to the correct depth.

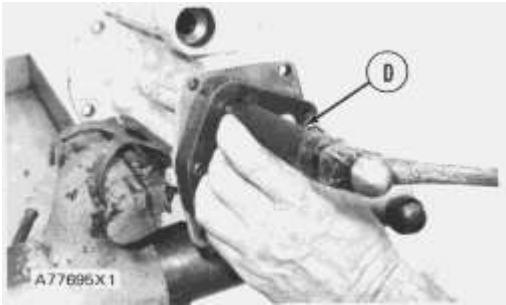

3. Install the rack bearing in the accessory drive end of the housing with tooling (D).

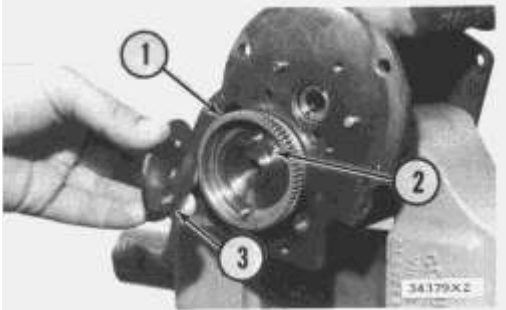

4. Put clean engine oil on camshaft. Install the camshaft in fuel injection pump housing. Put the governor drive gear (1) and spring (2) in position on the camshaft. Install the camshaft plate (3), bolt and lock.

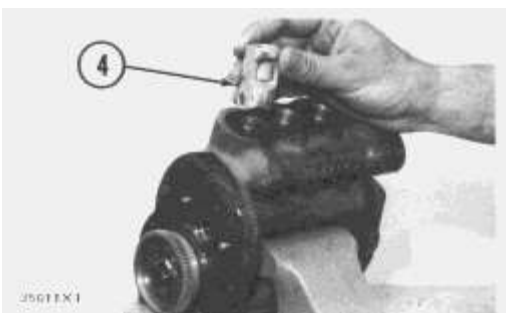

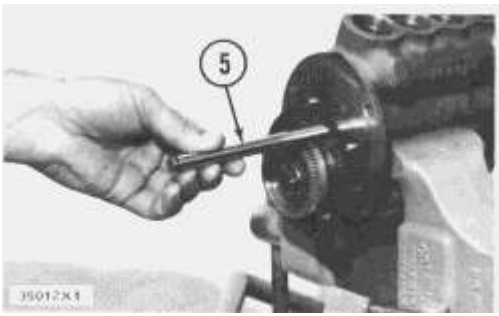

5. Install lifters (4) in their correct positions in the housing. Put clean engine oil on the rack. Install rack (5) in the fuel injection pump housing with the opening in the rack near the governor end of the housing.

6. Install the spacers in their respective positions in the housing. When new lifters and pumps are installed, it is necessary to make adjustment of the fuel pump timing. See FUEL INJECTION PUMP TIMING DIMENSIONS SETTING, OFF ENGINE in TESTING AND ADJUSTING.

7. Assemble the fuel injection pumps as follows:

a) Put clean fuel oil on all parts.

b) Install the spring on the barrel.

c) Install the washer on the plunger and gear segment. Install the plunger in the barrel.

d) Install the spring and check valve in the bonnet.

e) Put the bonnet in position on the barrel and install the ring to hold the unit together.

f) Install the seal on the bonnet.

NOTICE

Make sure the fuel rack is in the center (zero) position before the fuel injection pumps are installed.

8. Put the rack in the center position with tooling (E) as follows:

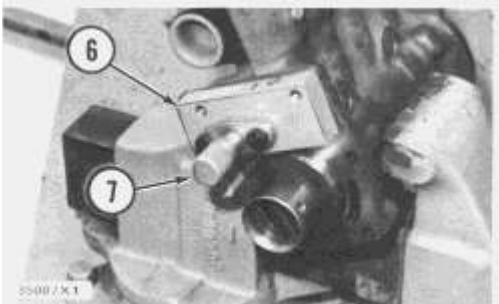

a) Install location fixture (6) on the fuel injection pump housing.

b) Install the gauge (7). Move the gauge (7) to zero. Push the rack (5) against the gauge.

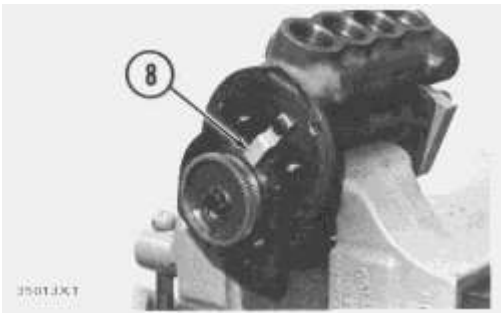

c) Install the clamp (8) on pump housing as illustrated. This will keep the rack in the center when the fuel injection pumps are installed.

9. With the rack in the center, install the fuel injection pumps as follows:

a) Turn the camshaft until the lobe of the camshaft is down for the pump to be installed.

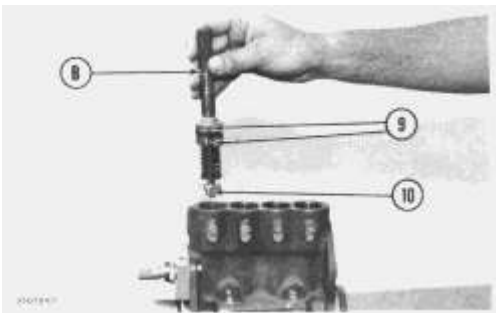

b) Install tool (B) on the pump.

c) Put the grooves (9) in the bonnet and barrel in alignment with the groove (10) in the pump gear segment. Put the pump in position so the grooves are in alignment with the guide pins in the housing bore. Install the pump in its correct position in the housing.

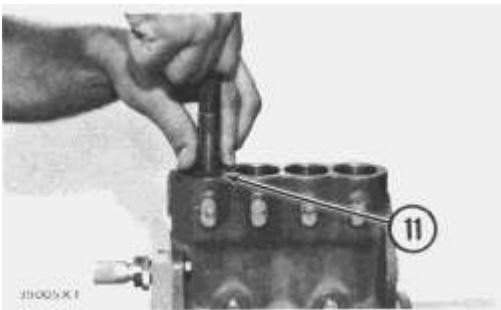

d) Install bushing (11) over the bonnet. Install tool (B) on the bonnet and push down on tool (B). Tighten bushing (11) by hand until the bushing is even with top of housing. If installation of the bushing can not be made this far by hand, remove it. Remove the pump, put the parts in alignment again and install the bushing again.

NOTICE

If installation of pump is correct, the bushing can be tightened by hand until it is even with face of pump housing.

e) Make a check of the rack travel after each pump is installed as follows:

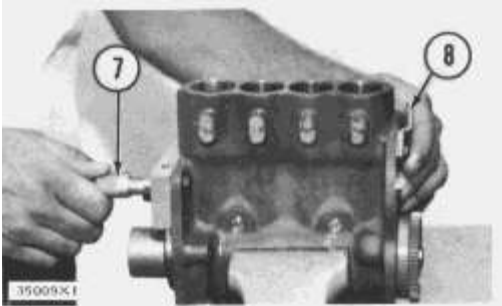

Move clamp (8) away from the end of the rack. Use gauge (7) to measure the rack movement. The total rack movement must be .800 in. (20.32 mm). If the rack can not be moved this distance, the pump gear segment is not in the correct position and the pump must be removed and installed again.



f) Remove tool (B) and tool (E). Install tool (A) and tighten the bushing to a torque of 150 ± 10 lb.ft. (205 ± 14 N·m). Remove tool (A). Install the washers and protection caps for the fuel injection pumps.

end by:

a) connection of governor to fuel injection pump housing

b) install fuel injection pump housing and governor

c) adjust governor and set the rack (See GOVERNOR ADJUSTMENTS and FUEL RACK SETTING in TESTING AND ADJUSTING)

Product: COMPACT WHEEL LOADER

Model: 910 COMPACT WHEEL LOADER 40Y

Configuration: 910 WHEEL LOADER 40Y00001-UP (MACHINE) POWERED BY 3204 ENGINE

Disassembly and Assembly 3204 VEHICULAR ENGINE FOR 910 WHEEL LOADER

Media Number -SEN7985-00

Publication Date -01/01/1980

Date Updated -12/10/2001

Accessory Drive Housing

SMCS - 1207-16; 1207-11; 1207-12; 1207-15

Remove Accessory Drive Housing

start by:

- a) remove fuel injection pump housing and governor
- b) remove valve cover

1. Put No. 1 piston at the top center compression position (TDC) with the following procedure:

- a) Remove the plug from the flywheel housing.

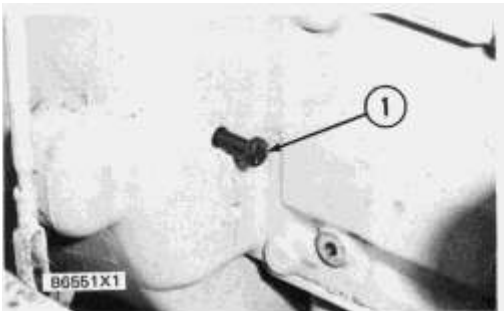

- b) Turn the crankshaft clockwise (as seen from the front of the engine) until a 3/8"-16 NC bolt (1) can be installed through the timing hole in the flywheel housing and into the hole in the flywheel.

NOTE: Never turn the crankshaft backward to install the bolt in the flywheel.

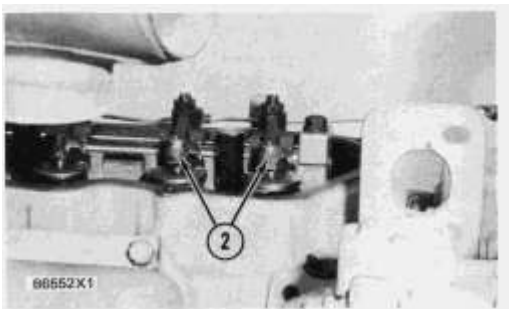

2. Check to see if both rocker arms (2) for the No. 1 piston can be moved backward and forward by hand.

NOTE: The No. 1 piston is at the top center compression position when the bolt is installed in the flywheel, and both rocker arms for No. 1 piston can be moved backward and forward. If both rocker arms can not be moved, the No. 1 piston is not at the top center compression position. Remove the bolt from the flywheel. Turn the crankshaft clockwise (as seen from the front of the engine) one full turn (360°) and install the bolt again.

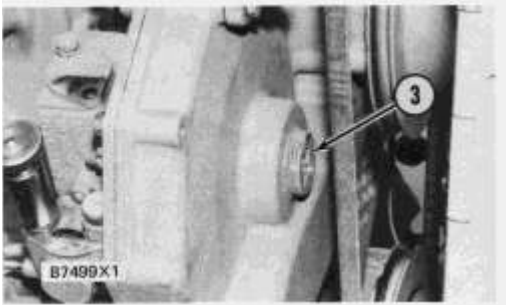

3. Remove plug (3) from the timing gear cover. Loosen the bolt that holds the accessory drive gear to the shaft.

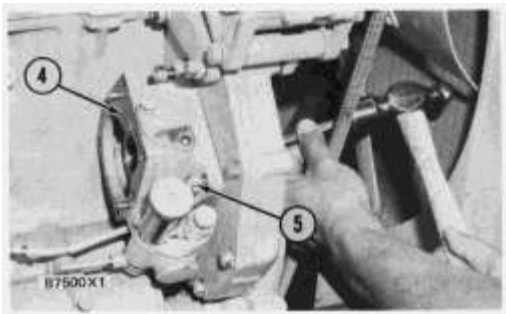

4. Loosen nuts (5) that hold the accessory drive to the timing gear plate.
5. Use a hammer and punch to hit the bolt and loosen the accessory drive gear from the shaft.

NOTICE

Remove the bolt from the accessory drive shaft but do not remove the bolt from the washer or accessory drive gear. Be extra careful not to let the washer and bolt fall into the timing gear cover.

6. Remove the bolt from the accessory drive shaft.
7. Remove nuts (5). Remove accessory drive housing (4).

Install Accessory Drive Housing

	Tools Needed	A
5P143	Timing Plate	1

NOTE: Make sure the No. 1 piston is at top center compression position and the timing bolt is installed in the flywheel.

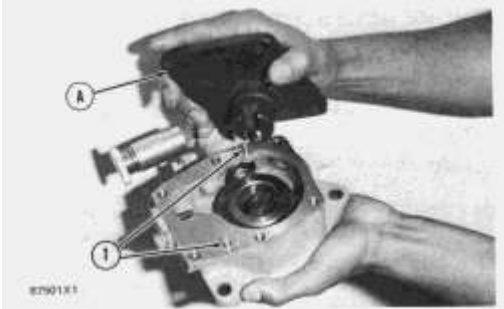

1. Turn the accessory drive shaft until tool (A) can be installed with the dowel holes in tool (A) in alignment with dowels (1) on the accessory drive housing. Use two of the bolts that are used to hold the fuel injection pump in place to hold tool (A) in position.

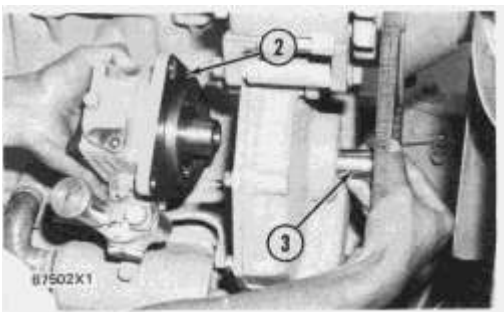

2. Make sure the O-ring seal is in position on the front of the accessory drive housing. Use a 3/4" deep well socket (3) to hold the accessory drive bolt and washer in place. Put accessory drive housing (2) in position on the timing gear plate while the bolt is started in the accessory drive shaft. Do not tighten the bolt at this time.

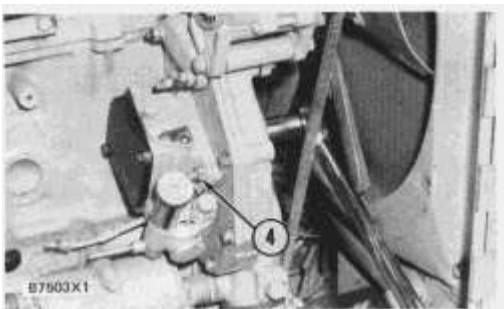

3. Install three nuts (4) that hold the accessory drive housing to the timing gear plate.

4. Tighten the bolt that holds the accessory drive gear to a torque of 110 ± 5 lb.ft. (149 ± 7 N·m).

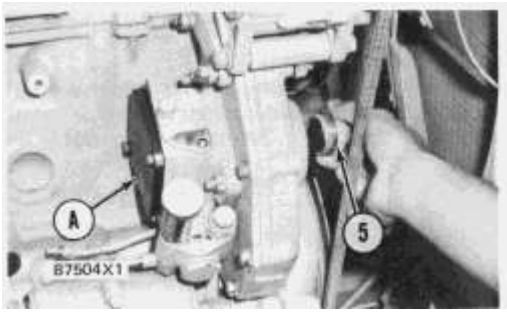

5. Install plug (5) in the timing gear cover. Remove tool (A).

end by:

a) install valve cover

b) install fuel injection pump housing and governor

Disassemble Accessory Drive Housing

Tools Needed		A	B
1P1861	Pliers	1	
9S9152	Bearing Puller Attachment		1

start by:

a) remove accessory drive housing



1. Remove fuel transfer pump (1).



2. Remove O-ring seal (2). Remove snap ring (3) with tool (A).

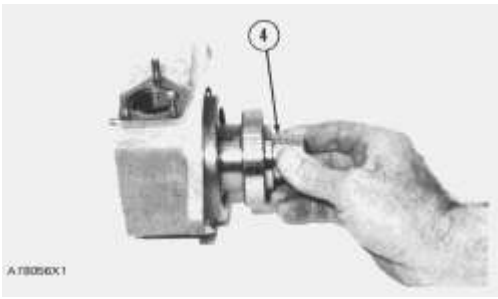

3. Remove shaft assembly (4) from the housing.

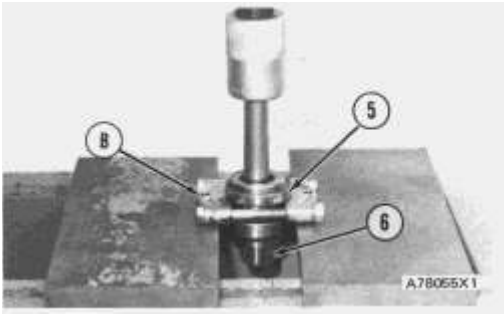

4. Remove shaft (6) from cam (5) with tool (B) and a press.

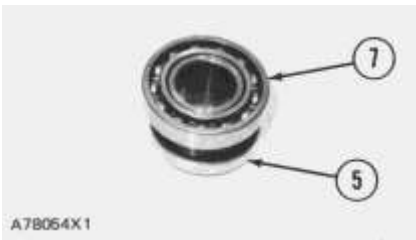

5. Remove bearing (7) from cam (5).

Assemble Accessory Drive Housing

Tools Needed		A
1P1861	Pliers	1

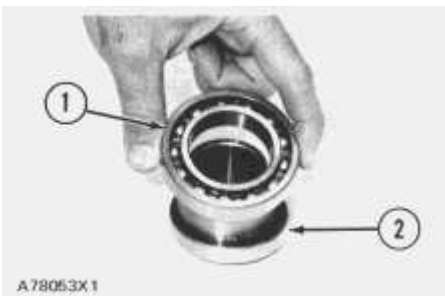

1. Install bearing (1) on cam (2).

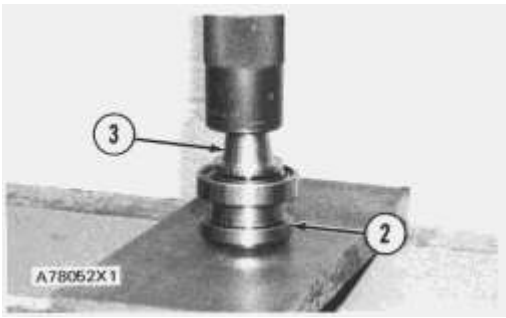

2. Install shaft (3) in cam (2) with a press.

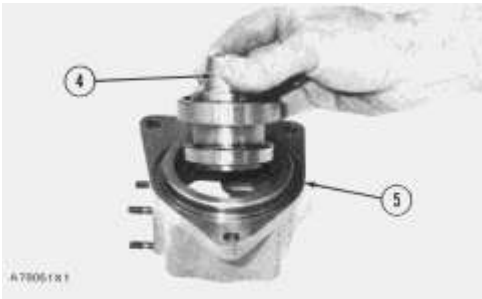

3. Put shaft assembly (4) in position in housing (5).

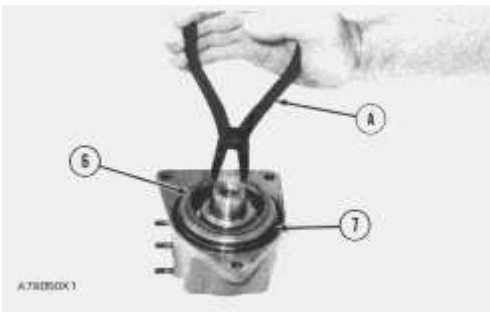

4. Install O-ring seal (7).

5. Install snap ring (6) with tool (A).

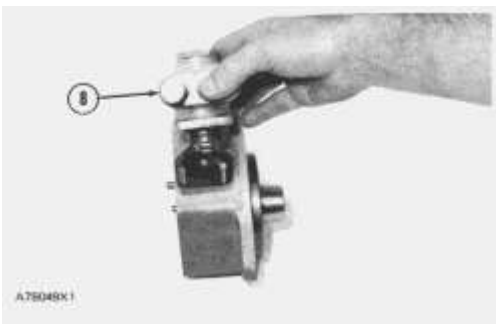

6. Install fuel transfer pump (8).

end by:

a) install accessory drive housing

Product: COMPACT WHEEL LOADER

Model: 910 COMPACT WHEEL LOADER 40Y

Configuration: 910 WHEEL LOADER 40Y00001-UP (MACHINE) POWERED BY 3204 ENGINE

Disassembly and Assembly 3204 VEHICULAR ENGINE FOR 910 WHEEL LOADER

Media Number -SEN7985-00

Publication Date -01/01/1980

Date Updated -12/10/2001

Radiator And Guard

SMCS - 1381-11; 1381-12

Remove Radiator And Guard

start by:

- a) remove engine side guards and hood
- b) remove battery
1. Drain the oil from the transfer gear case.
2. Drain the coolant from the cooling system.

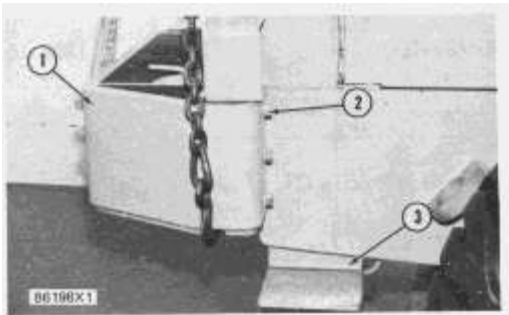

3. Remove plate assembly (3) from the frame.
4. Fasten a hoist to the bumper. Remove three bolts (2) from each side of the machine. Remove rear bumper (1). The weight of the rear bumper is 380 lb. (171 kg).

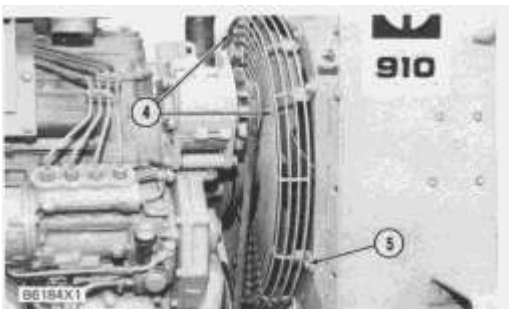

5. Remove bolts (5) that hold the fan guards to the shield assembly. Remove fan guards (4).

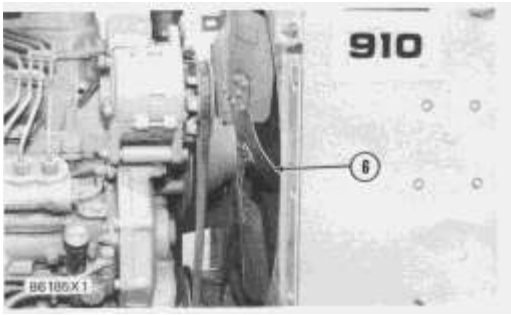

6. Remove the bolts that hold the fan to the adapter. Remove fan (6) from the adapter and put it against the radiator core. Fasten a wire to the fan and shield assembly so the fan cannot fall when the radiator and guard is removed.

NOTICE

Do not cause damage to the radiator core when the fan is put against it.

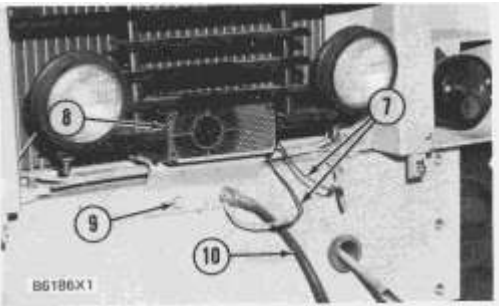

7. Disconnect wires (7) from the back-up alarm.

8. Remove bolts (9). Remove battery cable (10) and back-up alarm (8) from the frame.

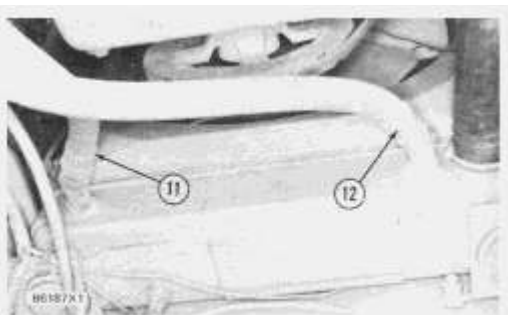

9. Disconnect hose assemblies (11) and (12) from the bottom of the radiator.

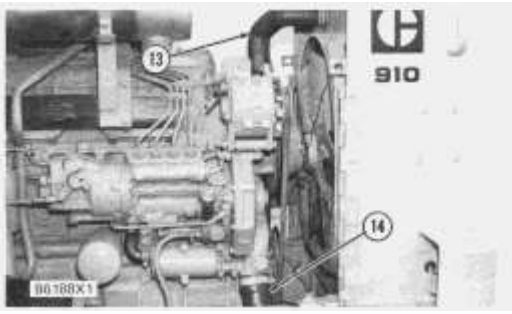

10. Remove inlet hose (13) and outlet hose (14) from the radiator.

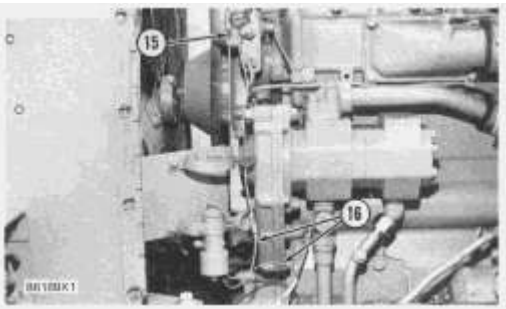

11. Disconnect wires (16) from the ether valve assembly.

12. Disconnect tube (15) from the tube assembly.

13. Disconnect two wires (not shown) from the back-up lights.

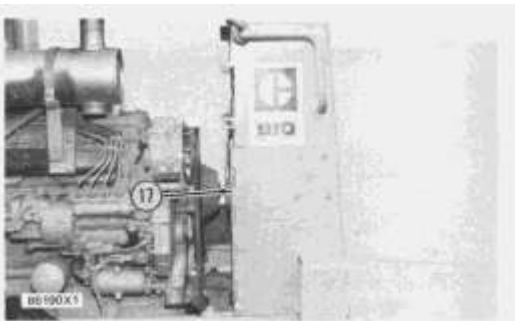

14. Fasten a hoist to the radiator guard. Remove the bolts that hold the radiator guard to the frame. Remove radiator and guard (17) from the frame. The weight of the radiator and guard is 270 lb. (122 kg).

Install Radiator And Guard

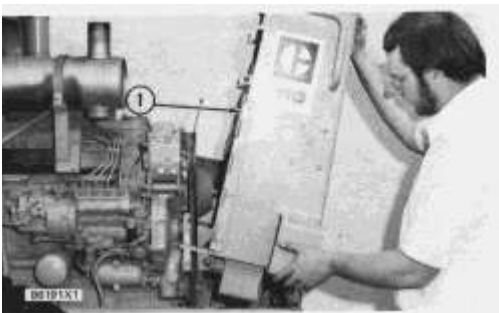

1. Fasten a hoist to the radiator guard. Put radiator and guard (1) in position on the frame. Install the bolts that hold it.

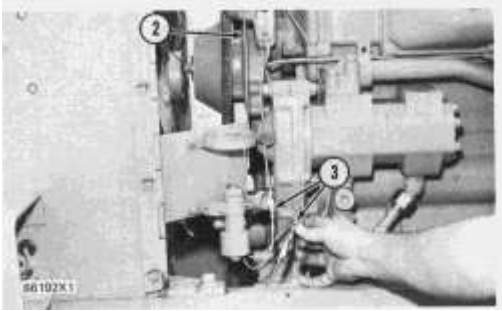

2. Connect tube (2) to the tube assembly.

3. Connect wires (3) to the ether valve assembly.

4. Connect two wires (not shown) to the back-up lights.

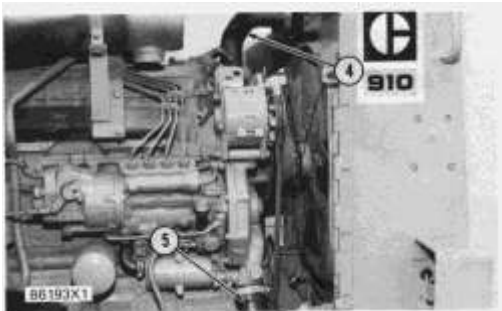

5. Install outlet hose (5) and inlet hose (4).

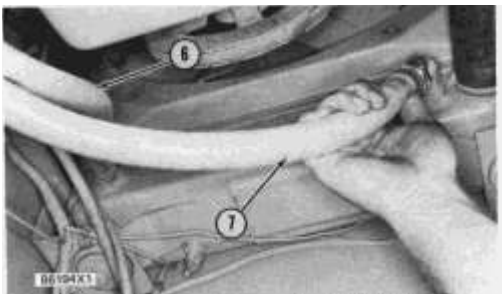

6. Connect hose assemblies (6) and (7) to the bottom of the radiator.

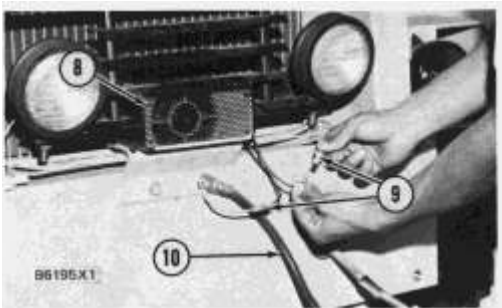

7. Put back-up alarm (8) and battery cable (10) in position on the frame. Install the bolts that hold them in place. Connect wires (9) to the back-up alarm.

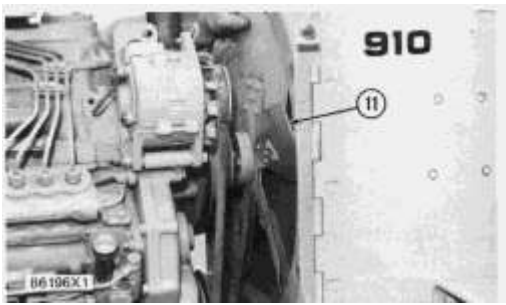

8. Put fan (11) in position on the adapter. Install the bolts that hold it.

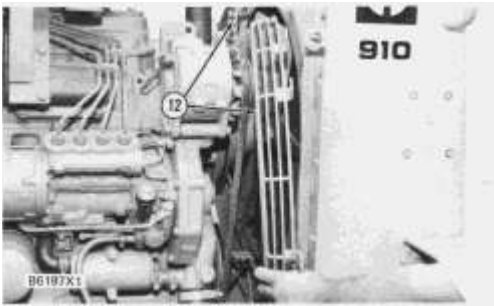

9. Install fan guards (12) on the shield assembly.

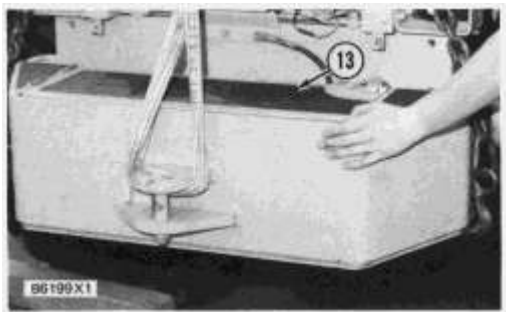

10. Fasten a hoist to the bumper. Put rear bumper (13) in position on the frame. Install the bolts that hold it. Tighten the bolts to a torque of 265 ± 35 lb.ft. (360 ± 47 N·m).

11. Install the plate assembly on the frame.

12. Fill the cooling system with coolant to the correct level. See LUBRICATION AND MAINTENANCE GUIDE.

13. Fill the transmission and transfer gears with oil to the correct level. See LUBRICATION AND MAINTENANCE GUIDE.

end by:

a) install engine side guards and hood

b) install battery

Product: COMPACT WHEEL LOADER

Model: 910 COMPACT WHEEL LOADER 40Y

Configuration: 910 WHEEL LOADER 40Y00001-UP (MACHINE) POWERED BY 3204 ENGINE

Disassembly and Assembly 3204 VEHICULAR ENGINE FOR 910 WHEEL LOADER

Media Number -SEN7985-00

Publication Date -01/01/1980

Date Updated -12/10/2001

Radiator

SMCS - 1353-11; 1353-12

Remove Radiator

Tools Needed		A
5P9736	Bracket-Link	4

start by:

a) remove radiator and guard

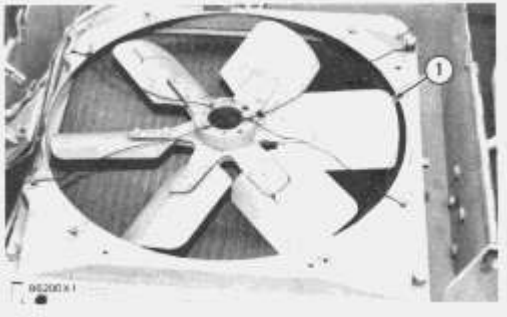

1. Remove the wire and remove fan (1) from the radiator.

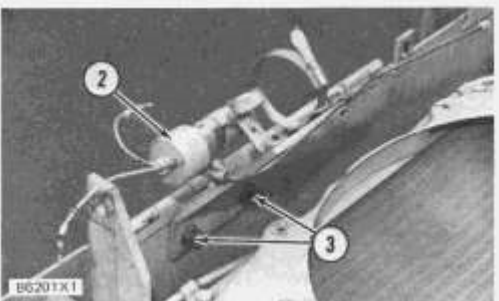

2. Remove nuts (3) and washers. Remove ether valve assembly (2) and bracket from the radiator guard as a unit.



Suggest:

For more complete manuals. Please go to the home page.

<https://www.ebooklibonline.com>

If the above button click is invalid. Please download this document first, and then click the above link to download the complete manual.

Thank you so much for reading

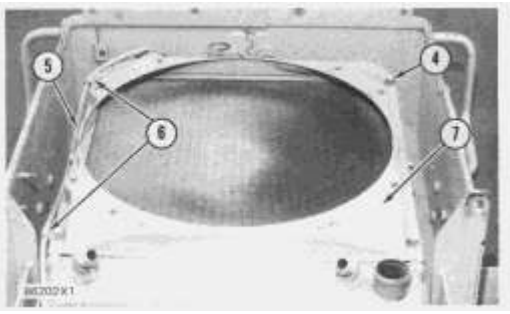

3. Disconnect clips (6) from the radiator. Remove tube (5).
4. Remove bolts (4). Remove shield assembly (7) from the radiator.

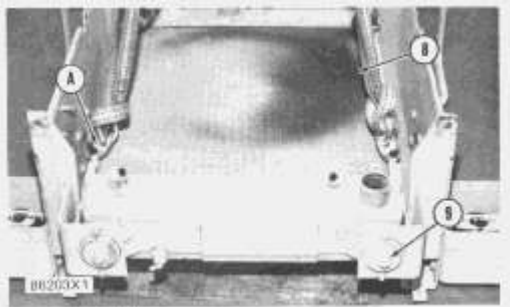

5. Fasten tooling (A) and a hoist to the radiator. Remove four bolts (9). Remove radiator assembly (8) from the guard assembly. The weight of the radiator assembly is 120 lb. (54 kg).

Install Radiator

Tools Needed		A
5P9736	Bracket-Link	4



1. Fasten tooling (A) and a hoist to the radiator. Put radiator assembly (1) in position in the guard assembly. Install the bolts that hold it.

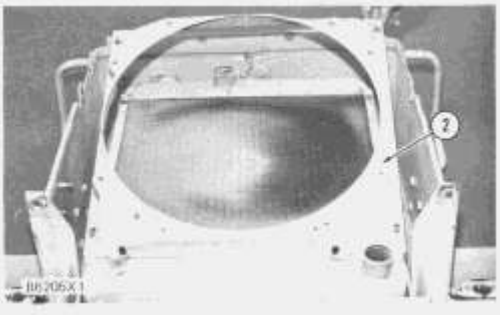

2. Install shield assembly (2) on the radiator.

NOTE: It can be necessary to make an adjustment to the location of the shield assembly on the radiator after the radiator and guard are installed on the frame. The clearance between the fan and shield assembly (2) must be equal on the top and bottom of the shield assembly with a minimum of .394 in. (10.0 mm) of clearance.

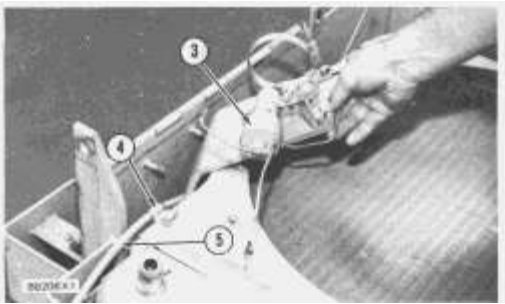

3. Install tube (5) on the radiator. Connect two clips (4).

4. Install ether valve assembly (3) and bracket on the guard assembly.

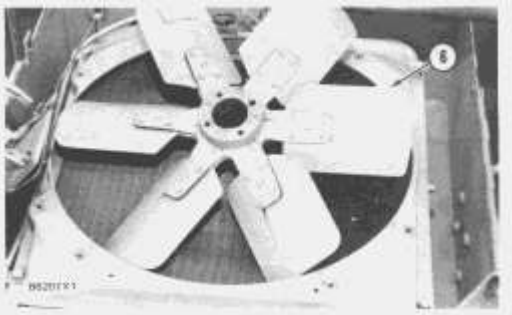

5. Put fan (6) in position against the radiator core. Fasten a wire to the fan and shield assembly so the fan can not fall when the radiator and guard are installed on the frame.

NOTICE

Do not cause damage to the radiator core when the fan is put against it.

end by:

a) install radiator and guard

<https://www.ebooklibonline.com>

Hello dear friend!

Thank you very much for reading.

Enter the link into your browser.

The full manual is available for immediate download.

<https://www.ebooklibonline.com>