

Product: COMPACT WHEEL LOADER

Model: 906H2 COMPACT WHEEL LOADER JRF

Configuration: 906H2 Wheel Loader JRF00001-UP (MACHINE) POWERED BY C3.3B Engine

## Disassembly and Assembly C2.6 and C3.3B Engines for Caterpillar Built Machines

Media Number -UENR0137-11

Publication Date -01/08/2015

Date Updated -12/07/2018

i05242445

# Fuel Injection Pump and Governor - Assemble

SMCS - 1286-016

## Assembly Procedure

Table 1

Required Tools			
Tool	Part Number	Part Description	Qty
A	390-1150	Injection Pump Gear Puller	1
	154-6360	Bolt	1
B	8H-0663	Bearing Puller	1

**Note:** Refer to Specification UENR0995 "Engine Design" for non-specified engine Torque Values.

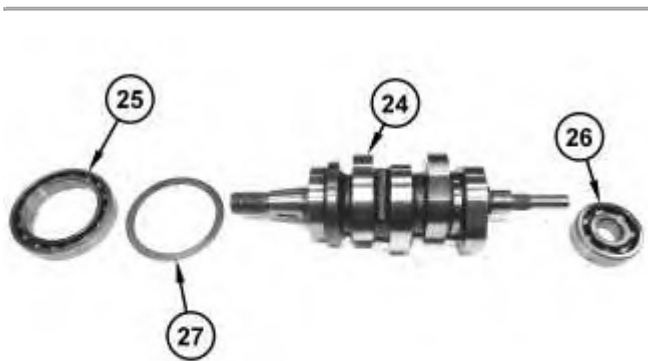

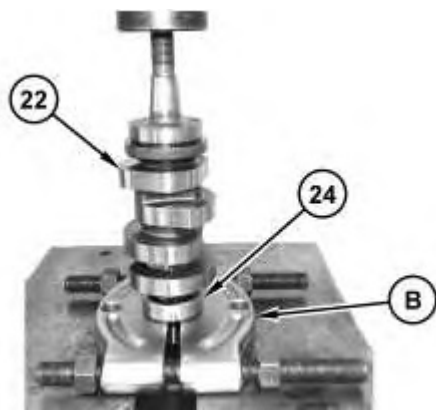

---

Illustration 2

g02807019

---

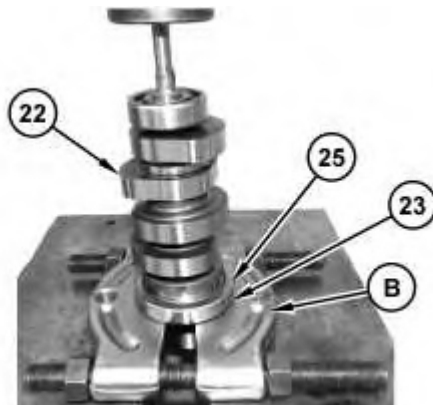

---

Illustration 3

g02807020

---

1. Use Tooling (B) and a suitable press to install bearings (26) onto fuel camshaft (24).
2. Position ring (27). Use Tooling (B) and a suitable press to install bearings (25) onto fuel camshaft (24).

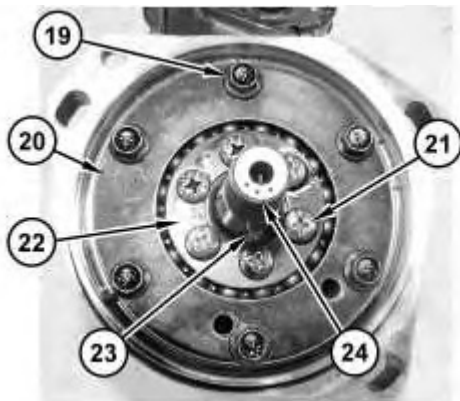

---

Illustration 4

g02805716

---

3. If necessary, replace key (23) with new. Position retaining plate (22) and install screws (21). Tighten screws (21) to a torque of 3.9 to 4.2 N·m (34.5 to 37.4 lb in).

4. Position fuel camshaft (24) in the housing assembly.
5. Position retaining plate (20) and install bolts (19). Tighten bolts (19) to a torque of 10 to 11 N·m (87 to 100 lb in).



---

Illustration 5

g02805660

6. Install gear (18).
7. Install nut (17) to gear (18).
8. For the C3.3B Tighten nut (17) to a torque of 138 to 156 N·m (102 to 115 lb ft).
9. For the C2.6 Tighten nut (17) to a torque of 93 to 102 N·m (69 to 75 lb ft).

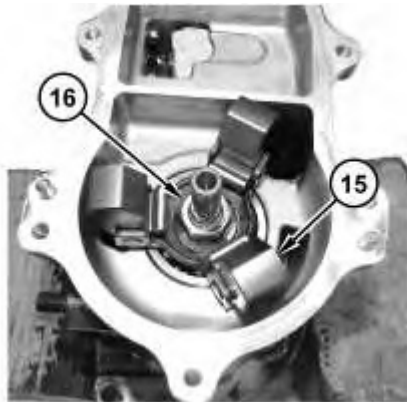

---

Illustration 6

g02805658

---

**<https://www.ebooklibonline.com>**

Hello dear friend!

Thank you very much for reading.

Enter the link into your browser.

The full manual is available for immediate download.

**<https://www.ebooklibonline.com>**

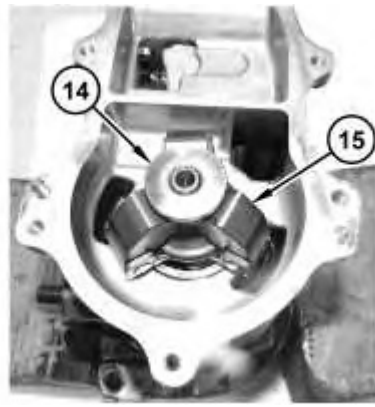

Illustration 7

g02805656

10. Position governor weights (15) and install nut (16). Tighten nut (16) to a torque of 63 to 72 N·m (47 to 53 lb ft). Install governor sleeve (14).

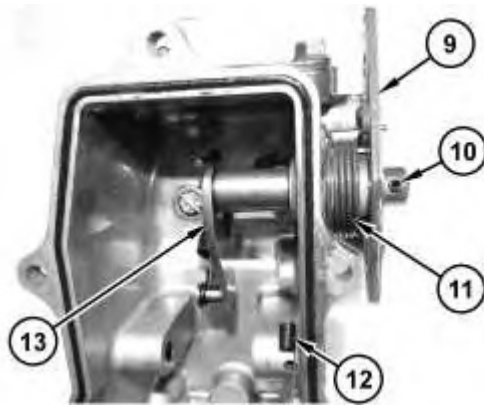
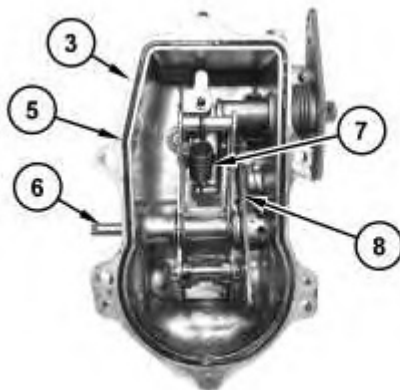

Illustration 8

g02805641

**Note:** Apply engine oil to all internal parts of governor.

11. Install O-ring seals on governor lever assembly (13). Position governor lever assembly (13) into the governor housing and install spring (12).
12. Install spring (11) and speed control lever (9) on governor lever assembly (13).
13. Install pin (10) into governor lever assembly (13).



14. Position governor lever (8). Install shaft (6) and spring (7) in governor housing assembly (3).
15. If necessary, replace O-ring seal (5) with new. Install O-ring seal (5) in governor housing assembly (3).

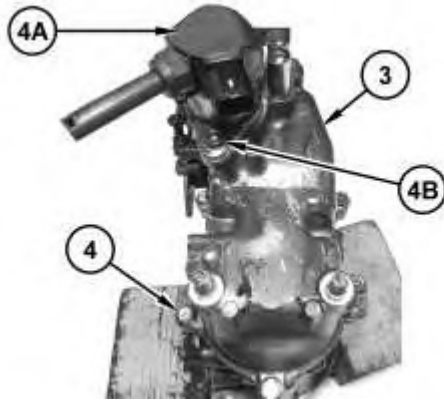

Illustration 10

16. Use a suitable blocking to support the fuel injection pump and governor. Position governor housing assembly (3) and install bolts (4). Tighten bolts (4) to a torque of 10 to 11 N·m (87 to 100 lb in).

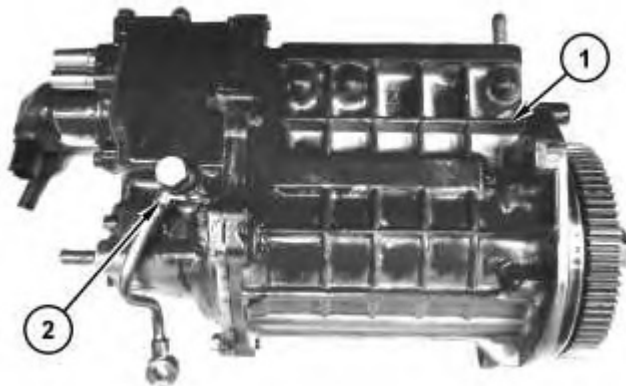

Illustration 11

17. Inspect fuel injection pump and governor (1) for installation.
18. Install tube (2).

**End By:**

- a. Install fuel injection pump and governor.
-

Product: COMPACT WHEEL LOADER

Model: 906H2 COMPACT WHEEL LOADER JRF

Configuration: 906H2 Wheel Loader JRF00001-UP (MACHINE) POWERED BY C3.3B Engine

## **Disassembly and Assembly C2.6 and C3.3B Engines for Caterpillar Built Machines**

Media Number -UENR0137-11

Publication Date -01/08/2015

Date Updated -12/07/2018

i05242446

# **Fuel Injection Pump and Governor - Install - C3.3B**

SMCS - 1286-012

S/N - A9W1-UP

S/N - A9Z1-UP

S/N - AJ71-UP

S/N - CE21-UP

S/N - DML1-UP

S/N - EML1-UP

S/N - F8C1-UP

S/N - FMR1-UP

S/N - FTK1-UP

S/N - GBJ1-UP

S/N - GTK1-UP

S/N - HAM1-UP

S/N - HEL1-UP

S/N - HMR1-UP

S/N - JBE1-UP

S/N - JRD1-UP

S/N - JRF1-UP

S/N - JRS1-UP

S/N - JSL1-UP

S/N - JSN1-UP

S/N - KTS1-UP

S/N - L661-UP

S/N - L771-UP

S/N - L881-UP

S/N - LST1-UP

S/N - MLT1-UP

S/N - MPW1-UP

S/N - NTL1-UP

S/N - PPT1-UP

S/N - RCX1-UP

S/N - SEN1-UP

S/N - STK1-UP

S/N - TAZ1-UP

S/N - TLK1-UP

S/N - WCT1-UP

## **Installation Procedure**

**Note:** Refer to Specification UENR0995 "Engine Design" for non-specified engine Torque Values.

---

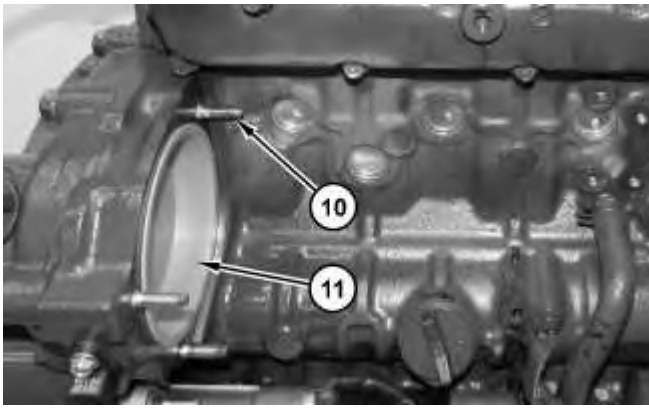

Illustration 1

g03177762

1. If necessary, install studs (10) and remove cover (11).

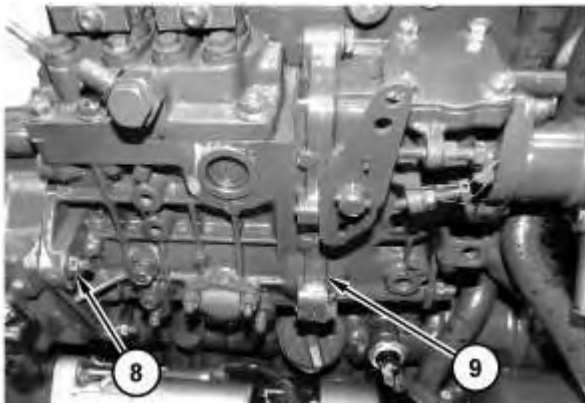

Illustration 2

g03177759

2. Install the O-ring seal on fuel injection pump and governor (9). Position fuel injection pump and governor (9) onto the flywheel housing.
3. Install three nuts (8) to fuel injection pump and governor (9). Tighten nuts (8) to a torque of 18 to 20 N·m (159 ± 177 lb in).

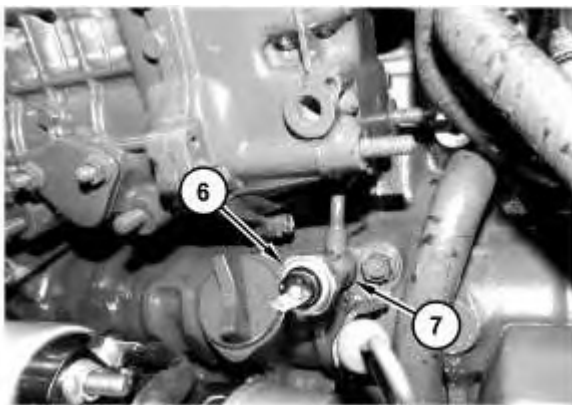

Illustration 3

g03177783

4. Apply engine oil to threads and torque fitting (7) to a torque of 16 to 19 N·m (12 to 14 lb ft).
5. Install engine oil pressure sensor (6) and connect the wiring harness assembly. Tighten the engine oil pressure sensor (6) to a torque of 15 to 19 N·m (11 to 14 lb ft).

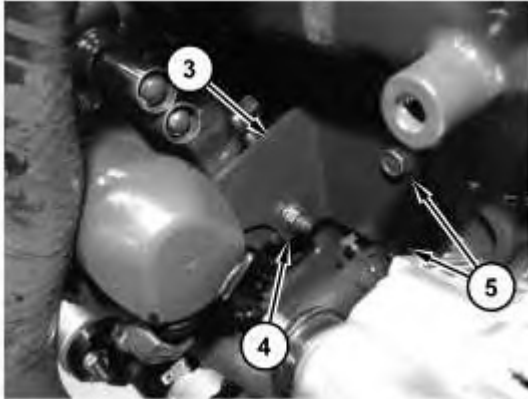

Illustration 4

g02804519

6. Position bracket (3) and install two nuts (4) and two bolts (5).



Illustration 5

g02804516

7. Check the timing marks and install the O-ring seal and oil plug cap (1). Install the O-ring seal and cover (2) on flywheel housing (3).

**End By:**

- a. Install the fuel injection lines.
-

Product: COMPACT WHEEL LOADER

Model: 906H2 COMPACT WHEEL LOADER JRF

Configuration: 906H2 Wheel Loader JRF00001-UP (MACHINE) POWERED BY C3.3B Engine

## Disassembly and Assembly C2.6 and C3.3B Engines for Caterpillar Built Machines

Media Number -UENR0137-11

Publication Date -01/08/2015

Date Updated -12/07/2018

i05242455

# Fuel Injection Pump - Remove and Install

SMCS - 1251-010

## Removal Procedure

Table 1

Required Tools			
Tool	Part Number	Part Description	Qty
A	390-1150	Injection Pump Gear Puller	1

### Start By:

- a. Remove fuel injection line.

**Note:** Refer to Specification UENR0995 "Engine Design" for non-specified engine Torque Values.

1. Turn the fuel supply to the OFF position.
2. Turn the battery disconnect switch to the OFF position.

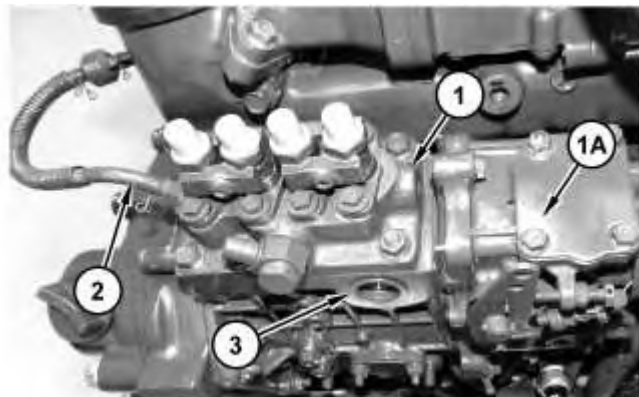

3. Disconnect hose assembly (2) from fuel injection pump (1).
4. Remove sight cover (3) from fuel injection pump (1).

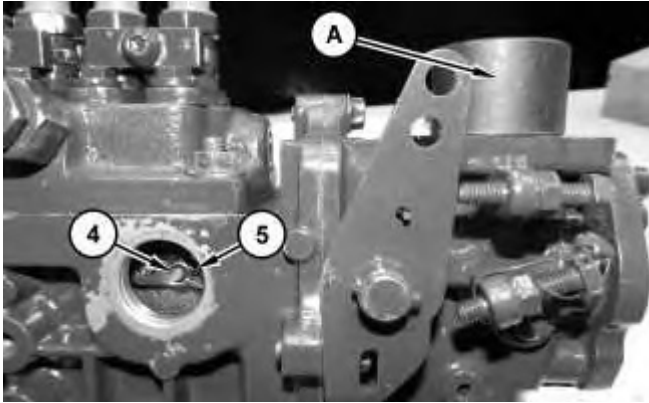

Illustration 2

5. Remove the shutoff solenoid and cover (1A). Install Tooling (A) to hold back the governor control arm and assist removing the spring (5) and nut (4).

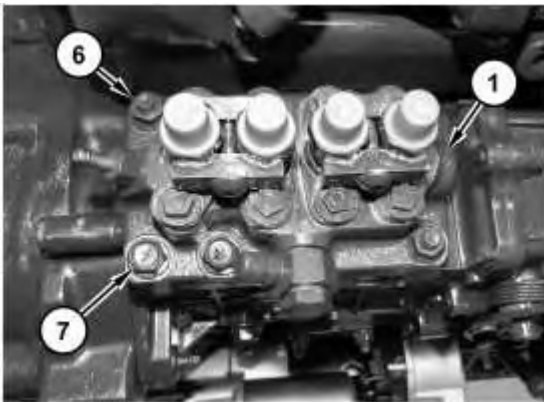

Illustration 3

6. Disconnect spring (5) and attach a thin wire (6) to spring (5). Remove nut (4). Position the lever (7) off the stud.



**Personal injury can result from parts and/or covers under spring pressure.**

**Spring force will be released when covers are removed.**

**Be prepared to hold spring loaded covers as the bolts are loosened.**

---

7. Remove two nuts (6) and four bolts (7) from fuel injection pump (1). The fuel injection pump (1) is spring loaded.
8. Carefully remove fuel injection pump (1) from the fuel injection pump housing.

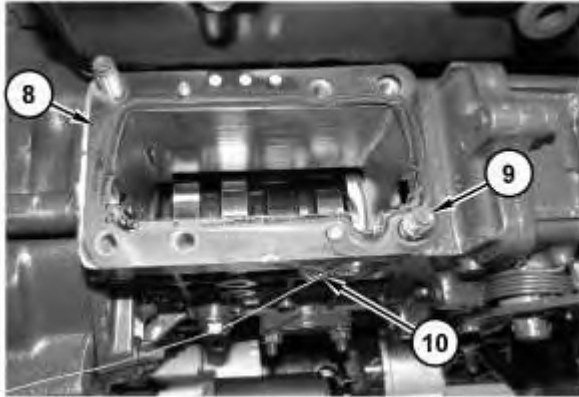

Illustration 4

g02781040

9. Remove gasket shims (8).
10. If necessary, remove studs (9) from the fuel injection pump housing.
11. To secure the spring from falling inside the housing use wire (10).
12. Clean fuel injection pump (1) and the area around the fuel injection pump. Ensure that the area is free from contamination before beginning installation.

## Installation Procedure

---

### NOTICE

**Refer to System Operation, Testing and Adjusting, "Cleanliness of Fuel System Components" for detailed information on the standards of cleanliness that must be observed during ALL work on the fuel system.**

---

---

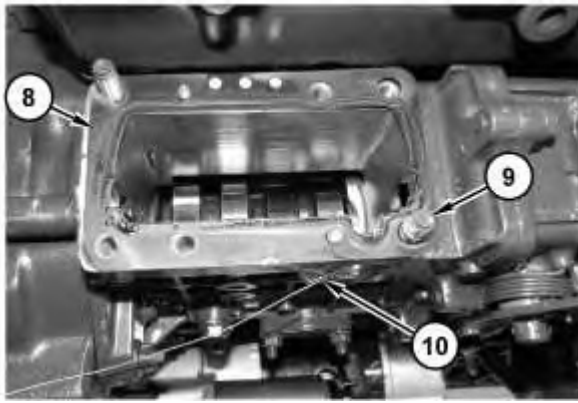

---

Illustration 5

g02781040

1. Keep wire (10) secure to the spring to prevent falling into the housing.
2. If necessary, install studs (9) into the fuel injection pump housing.
3. Position new gasket shims (8) onto the fuel injection pump housing.

**Note:** When you disassemble or replace, make sure that you use the same number of new gasket shims with the same thickness.

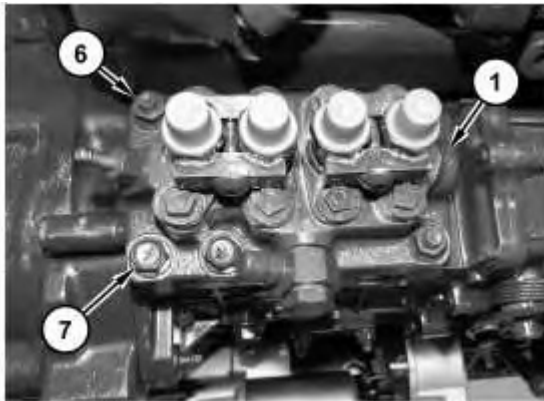

---

Illustration 6

g02781105

4. Carefully install fuel injection pump (1) into the fuel injection pump housing .
  5. Install four new bolts (7) into fuel injection pump (1). Install two nuts (6) into fuel injection pump (1). Tighten bolts (7) to a torque of 24 to 27 N·m (214 to 240 lb in). Tighten nuts (6) to a torque of 18 to 20 N·m (159 to 178 lb in).
-

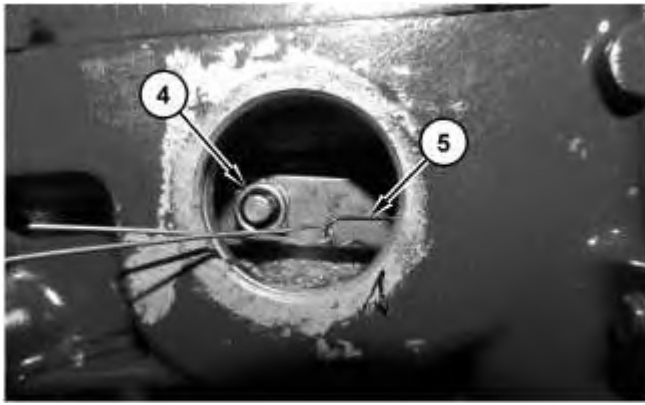

Illustration 7

g02781722

6. Position the lever on the stud. Install nut (4) to hold the lever in place. Tighten nut (4) to a torque of 3 to 4 N·m (26 to 36 lb in).
7. Connect spring (5) with the thin wire.

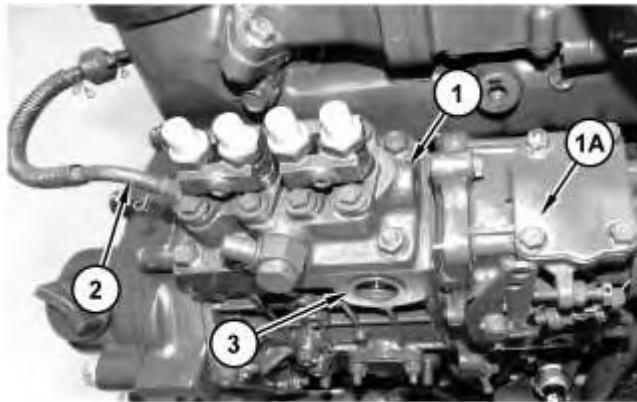

Illustration 8

g02781037

8. Install sight cover (3).
9. Connect hose assembly (2) to fuel injection pump (1).
10. Turn the fuel supply to the ON position.
11. Turn the battery disconnect switch to the ON position.
12. After replacement of the fuel injection pump, the fuel injection pump must be calibrated. Refer to System Operation, Testing and Adjusting, "Fuel Injection Timing - Check".

**End By:**

- a. Install fuel injection lines.

Product: COMPACT WHEEL LOADER

Model: 906H2 COMPACT WHEEL LOADER JRF

Configuration: 906H2 Wheel Loader JRF00001-UP (MACHINE) POWERED BY C3.3B Engine

## **Disassembly and Assembly C2.6 and C3.3B Engines for Caterpillar Built Machines**

Media Number -UENR0137-11

Publication Date -01/08/2015

Date Updated -12/07/2018

i05242458

# **Turbocharger - Remove and Install - C3.3B**

SMCS - 1052-010

S/N - A9W1-UP

S/N - A9Z1-UP

S/N - AJ71-UP

S/N - CE21-UP

S/N - DML1-UP

S/N - EML1-UP

S/N - F8C1-UP

S/N - FMR1-UP

S/N - FTK1-UP

S/N - GBJ1-UP

S/N - GTK1-UP

S/N - HAM1-UP

S/N - HEL1-UP

S/N - HMR1-UP

S/N - JBE1-UP

S/N - JRD1-UP

S/N - JRF1-UP

S/N - JRS1-UP

S/N - JSL1-UP

S/N - JSN1-UP

S/N - KTS1-UP

S/N - L661-UP

S/N - L771-UP

S/N - L881-UP

S/N - LST1-UP

S/N - MLT1-UP

S/N - MPW1-UP

S/N - NTL1-UP

S/N - PPT1-UP

S/N - RCX1-UP

S/N - SEN1-UP

S/N - STK1-UP

S/N - TAZ1-UP

S/N - TLK1-UP

S/N - WCT1-UP

## **Removal Procedure**

**Note:** Refer to Specification UENR0995 "Engine Design" for non-specified engine Torque Values.

---

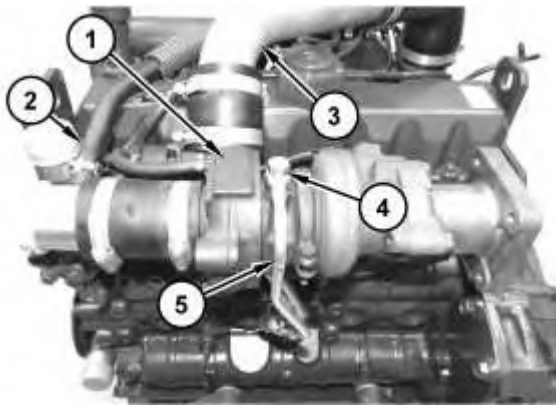

Illustration 1

g02782212

1. Disconnect hose assembly (2) from turbocharger (1).
2. Remove tube assembly (3) from turbocharger (1).
3. Remove bolt (4) and the four lower bolts. Remove tube assemblies (5) and the gasket and the O-ring seal.

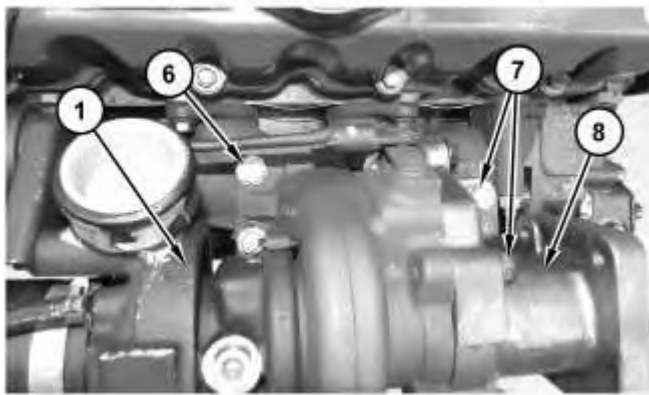

Illustration 2

g02782214

4. Remove five bolts (7) and housing (8) and the gasket.
5. Remove four nuts (6) and turbocharger (1) and the gasket.

## Installation Procedure

Table 1

Required Tools			
Tool	Part Number	Part Description	Qty
A	-	Loctite C5A	1

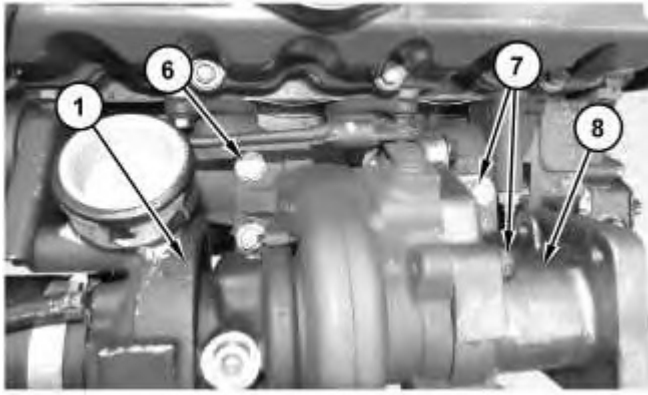

Illustration 3

g02782214

1. If necessary, install new gaskets.
2. Position the gasket and install turbocharger (1) on the exhaust manifold.
3. Position the gasket and install housing (8) on the turbocharger (1) and install three bolts (7) to align turbocharger (1).
4. Apply Tooling (A) to three nuts (6) and install three nuts (6) on turbocharger (1). Tighten three nuts (6) and remove three bolts (7) and housing (8).
5. Apply Tooling (A) to one nut (6) and install one nut (6) on turbocharger (1). Tighten one nut (6).
6. Position the gasket and housing (8). Apply Tooling (A) on bolts (7) and install five bolts (7) and tighten.

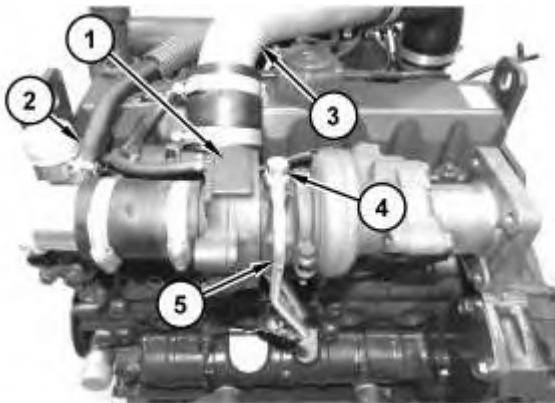

Illustration 4

g02782212

7. Position tube assemblies (5) and the gasket and the O-ring seal and install four lower bolts and bolt (4). Tighten bolt (4) to a torque of  $16.0 \pm 19.0$  N·m ( $11.80 \pm 14.01$  lb ft).
8. Position tube assembly (3) on turbocharger (1) and install the clamps.
9. Connect hose assembly (2) on turbocharger (1).

Product: COMPACT WHEEL LOADER

Model: 906H2 COMPACT WHEEL LOADER JRF

Configuration: 906H2 Wheel Loader JRF00001-UP (MACHINE) POWERED BY C3.3B Engine

## **Disassembly and Assembly C2.6 and C3.3B Engines for Caterpillar Built Machines**

Media Number -UENR0137-11

Publication Date -01/08/2015

Date Updated -12/07/2018

i05242471

# **Exhaust Gas Recirculation Valve - Remove and Install - C3.3B Tier 4 Interim/Stage 3A**

SMCS - 108N-010

S/N - A9Z1-UP

S/N - AJ71-UP

S/N - CE21-UP

S/N - DML1-UP

S/N - F8C1-UP

S/N - FMR1-UP

S/N - FTK1-UP

S/N - GBJ1-UP

S/N - HAM1-UP

S/N - HEL1-UP

S/N - JBE1-UP

S/N - JRD1-UP

S/N - JRF1-UP

S/N - JRS1-UP

S/N - JSL1-UP

S/N - JSN1-UP

S/N - L661-UP

S/N - L771-UP

S/N - L881-UP

S/N - LST1-UP

S/N - NTL1-UP

S/N - RCX1-UP

S/N - SEN1-UP

S/N - TAZ1-UP

S/N - TLK1-UP

## Removal Procedure

**Note:** Refer to Specification UENR0995 "Engine Design" for non-specified engine Torque Values.



### WARNING

**Personal injury can result from hot coolant, steam and alkali.**

**At operating temperature, engine coolant is hot and under pressure. The radiator and all lines to heaters or the engine contain hot coolant or steam. Any contact can cause severe burns.**

**Remove cooling system pressure cap slowly to relieve pressure only when engine is stopped and cooling system pressure cap is cool enough to touch with your bare hand.**

**Do not attempt to tighten hose connections when the coolant is hot, the hose can come off causing burns.**

**Cooling System Coolant Additive contains alkali. Avoid contact with skin and eyes.**

---

### NOTICE

**Care must be taken to ensure that fluids are contained during performance of inspection, maintenance, testing, adjusting, and repair of the product. Be prepared to collect the fluid with suitable containers**



**Suggest:**

**For more complete manuals. Please go to the home page.**

**<https://www.ebooklibonline.com>**

**If the above button click is invalid. Please download this document first, and then click the above link to download the complete manual.**

**Thank you so much for reading**

before opening any compartment or disassembling any component containing fluids.

Refer to Special Publication, NENG2500, "Dealer Service Tool Catalog" for tools and supplies suitable to collect and contain fluids on Cat products.

Dispose of all fluids according to local regulations and mandates.

---



Illustration 1

g02824663

1. Drain coolant below exhaust gas recirculation valve level. Remove heat shield (1).

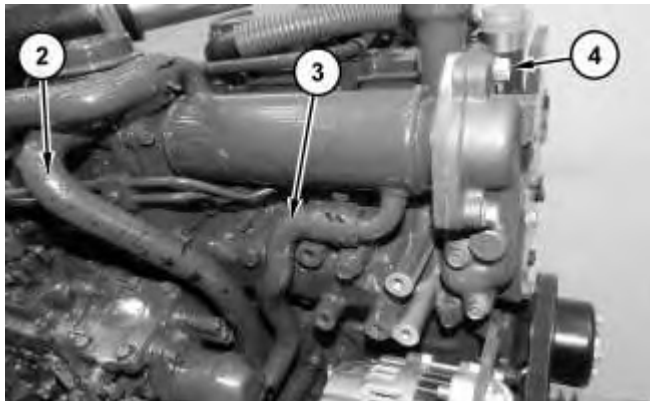
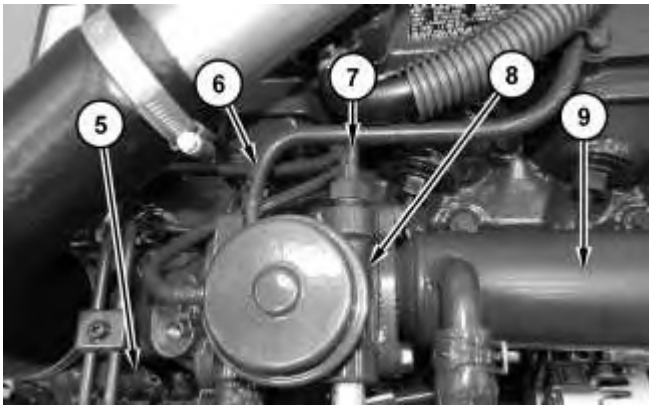

Illustration 2

g02824816

2. Disconnect hoses (2) and (3). Remove bolts (4).
-



---

Illustration 3

g02824896

3. Disconnect hoses (6) and (7). Remove bolts (5) and remove exhaust gas recirculation valve (8) and cooler assembly (9).

## Installation Procedure

1. Install exhaust gas recirculation valve (8) in the reverse order of removal.
    - a. Tighten the valve for hose (7) to a torque of 30.0 to 39.0 N·m (22.13 to 28.76 lb ft).
-