

**Parts Manual**

Part No: 272494200 (08-00)

**Elenco Ricambi**

**Manuel des Pièces de Rechange**

**Ersatzteilkatalog**

**Manual de Repuestos**

**CE**

***MS10 - MS12***

**Yale** 

**Specify the following information when ordering spare parts:**

- truck model;
- truck serial number;
- table N°;
- part number of required component;
- quantity;
- part description

**Per ordinare parti di ricambio specificare:**

- tipo della macchina;
- matricola della macchina;
- n° della tavola;
- numero di codice del particolare richiesto;
- quantità di particolari richiesti;
- denominazione del particolare richiesto.

**Pour les commander les pièces détachées veuillez préciser:**

- type machine;
- n° matricule;
- n° plan;
- n° code de la pièce;
- nombre de pièces;
- désignation de la pièce.

**Zum Bestellen von Ersatzteilen bitte folgende Angaben machen:**

- Staplertyp;
- Seriennummer der Maschine;
- Tafel-Nr.;
- Best. Nr. des erforderlichen Teils;
- Erforderliche Stückzahl;
- Bezeichnung des erforderlichen Teils.

**Para solicitar los repuestos especificar:**

- tipo de la máquina;
- matrícula de la máquina;
- n° de la máquina;
- número de código de la pieza solicitada;
- cantidad de piezas solicitadas;
- denominación de la pieza solicitada.

**Part Sheet index - Indice delle tavole - Index des tables -Tafelverzeichnis - Indice de tablas**

PART SHEET 1.A PAGE N° 4	PART SHEET 2.A PAGE N° 6	PART SHEET 3.A PAGE N° 8	PART SHEET 4.A PAGE N° 10
COVERS/ADESIVE LABELS	SUPPORTS AND CASTER WHEELS	LOAD WHEELS	TRACTION UNIT
CARTER/TARGHETTE ADESIVE	SUPPORTI E RUOTA PIROETTANTE	RUOTE DI CARICO	GRUPPO TRAZIONE
COUVERCLE/AUTOCOLLANTS DE SEGNALESION	SUPPORTS ET ATTELAGE	ATTELAGES	GROUPE DE TRACTION
DECKEL/ABZ.-BILD	LAGERN UND RÄDER	RÄDER	ZUGAGGREGAT
TAPAS/ADESIVOS DE AVISO	SOPORTES Y RUEDA	RUEDAS	GRUPO DE TRACCION
PART SHEET 5.A PAGE N° 12	PART SHEET 6.A PAGE N° 14	PART SHEET 7.A PAGE N° 16	PART SHEET 8.A PAGE N° 18
TRACTION MOTOR	MAGNETIC BRAKE	DRAWBAR CONTROL BOX	DRAWBAR CONTROL BOX OPT
MOTORE TRAZIONE	FRENO ELETTRICO-MAGNETICO	TIMONE SCATOLA COMANDI	TIMONE SCATOLA COMANDI OPT
MOTEUR DE TRACTION	FREIN ELETTRICOMAGN.	BARRE BOITE DE COMMANDE	BARRE BOITE DE COMMANDE OPT
ZUGMOTOR	ELEKTROMAGN. BREMSE	DEICHSEL STEUERUNGSBUCHSE	DEICHSEL STEUERUNGSBUCHSE OPT
MOTOR DE TRACCION	FRENO ELECTROM.	DIRECCION DE MANDOS	DIRECCION DE MANDOS OPT
PART SHEET 9.A PAGE N° 20	PART SHEET 10.A PAGE N° 22	PART SHEET 11.A PAGE N° 24	PART SHEET 12.A PAGE N° 26
DISTRIBUTOR	HYDRAULIC SYSTEM	MAST 1 STAGE FFL	MAST 2 STAGE HI-VI
CENTRALINA IDRAULICA	IMPIANTO IDRAULICO	MONTANTI 1 STADIO FFL	MONTANTI 2 STADI HI-VI
DISTRIBUTEUR	INSTALLATION HYDRAULIQUE	MAT 1 ETAGE FFL	MAT 2 ETAGES HI-VI
STEUERUNG	HYDRAULIKANLAGE	HUBGERÜST 1ST. FFL	HUBGERÜST 2 ST. HI-VI
DISTRIBUIDOR	INSTALACION HIDRAULICA	MASTIL 1 ESTADIO FFL	MASTIL 2 ESTADIOS HI-VI
PART SHEET 13.A PAGE N° 28	PART SHEET 14.A PAGE N° 30	PART SHEET 15.A PAGE N° 32	PART SHEET 16.A PAGE N° 34
MAST 3 STAGE HI-VI	HYDRAULIC CYLINDER	FORKS	WIRE NET
MONTANTI 3 STADI HI-VI	CILINDRI IDRAULICI	FORCHE	RETI DI PROTEZIONE
MAT 3 ETAGES HI-VI	CYLINDRES HYDRAULIQUES	FOURCHES	GRILLAGE
HUBGERÜST 3 ST. HI-VI	HYDRAULIK ZYLINDER	FORKE	DRAHNETZ
MASTIL 3 ESTADIOS HI-VI	CILINDROS IDRAULICOS	HORCAS	RED

**Part Sheet index - Indice delle tavole - Index des tables -Tafelverzeichnis - Indice de tablas**

<b>PART SHEET 17.A PAGE N° 36</b>	<b>PART SHEET 18.A PAGE N° 37</b>	<b>PART SHEET 19.A PAGE N° 38</b>	<b>PART SHEET 20.A PAGE N° 39</b>
WIRING DIAGRAM	SHEATH DIAGRAM	ELECTRICAL DIAGRAM	HYDRAULIC DIAGRAM
SCHEMA COLLEGAMENTO CAVI DI POTENZA	SCHEMA COLLEGAMENTO GUAINA	SCHEMA ELETTRICO	SCHEMA IDRAULICO
DIAGRAMME LIAISON CABLE ELECTRIQUE	DIAGRAMME LIAISON GAINES	SCHEMA ELECTRIQUE	SCHEMA HYDRAULIQUE
ELEKTRTSCHENANLAGEPLAN	MONTELANLAGEPLAN	SCHALTPLAN	HYDRAULIKPLAN
ESQUEMA CONEXION CABLE POTENCIA	ESQUEMA CONEXION VAINA	ESQUEMA ELECTRICO	ESQUEMA HIDRAULICO
<b>PART SHEET 21.A PAGE N°40</b>	<b>PART SHEET 22.A PAGE N°42</b>	<b>PART SHEET 23.A PAGE N°44</b>	<b>PAGE N°46</b>
BATTERY CHARGER	CONSOLE ADAPTER	CONTACTS,CONNECTORS,TOOLS	NUMERICAL INDEX
CARICA BATTERIE	ADATTATORE PER CONSOLE	CONTATTI,CONNETTORI,UTENSILI	INDICE NUMERICO
CHARGUER	ADAPTATEUR POUR CONSOLE	CONNECTEURS,CONTACTS,OUTILS	INDEX GENERAL
AULFLADERÄT	ADAPTER FÜR KONSOLLE	KONNEKTORS,KONTAKTS,WERKZEUG	ALGEMEINER INDEX
CARGADOR BATERIAS	ADAPTADOR POR CONSOLA	CONTACTO,CONECTOR,UTENSILIO	INDICE GENERAL

**<https://www.ebooklibonline.com>**

Hello dear friend!

Thank you very much for reading.

Enter the link into your browser.

The full manual is available for immediate download.

**<https://www.ebooklibonline.com>**

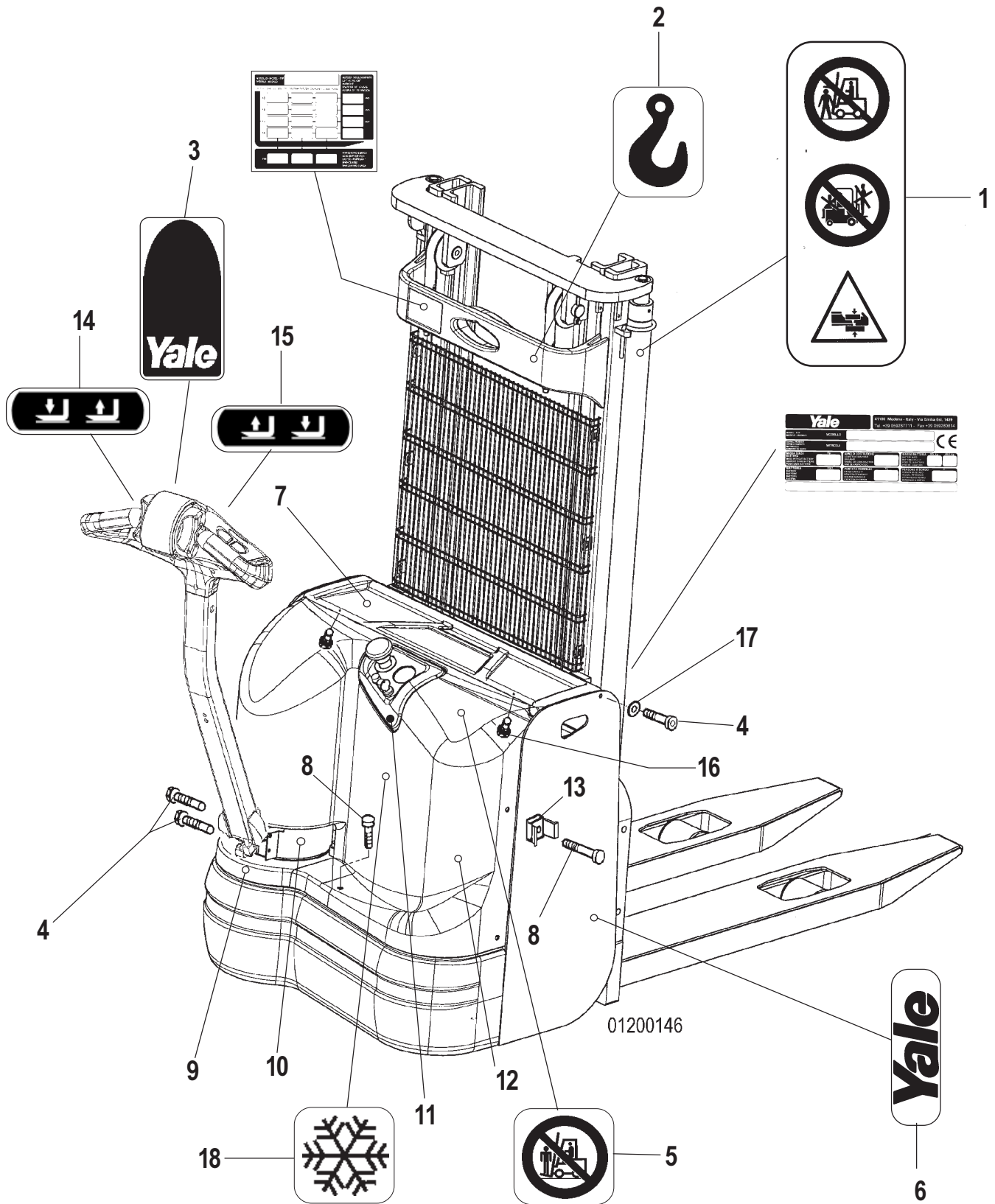

Da matr. / Du matr. / Ab. seriennummer  
 From serial N° / Desde la matr.:

Fino a matr. / Jusqu' matr. / Bis zur serien-Nr.  
 Until serial N° / Hasta la matr.:

Ad esclusione di / À l'exclusion de  
 Mit ausnahme von / With the exception of / Excepto:

Compreso / Avec / Einschließlich  
 Including / Con:

**B846X01578X**

**B846X01579X-80X-81X-85X  
 87X-89X-91X-93X-94X-95X-97X**

REF	PART N°	Qt.	DESCRIPTION	DESCRIZIONE	DESIGNATION	BENENNUNG	DENOMINACIONES
1	272303000	2	Adhesive label	Adesivo	Autocollants	Abz-bild	Adesivos
2	272213500	1	Adhesive label	Adesivo	Autocollants	Abz-bild	Adesivos
3	524139322	1	Adhesive label	Adesivo	Autocollants	Abz-bild	Adesivos
4	272328700	6	Screws	Viteria	Vis	Schrauben	Tornillos
5	272213200	1	Adhesive label	Adesivo	Autocollants	Abz-bild	Adesivos
6	580013471	2	Adhesive label	Adesivo	Autocollants	Abz-bild	Adesivos
7	580013323	1	Battery cover (battery 140-200Ah)	Coperchio batteria (batteria 140-200Ah)	Couvercle batterie (batterie 140-200Ah)	Batterie deckel (batterie 140-200Ah)	Cubierta bateria (bateria 140-200Ah)
7	580013324	1	Battery cover (battery 250Ah)	Coperchio batteria (batteria 250Ah)	Couvercle batterie (batterie 250Ah)	Batterie deckel (batterie 250Ah)	Cubierta bateria (bateria 250Ah)
8	272033100	4	Screws	Viteria	Vis	Schrauben	Tornillos
9	524141524	1	Cover	Carter inferiore	Couvercle	Deckel	Tapa
10	580013326	1	Tiller ring	Anello timone	Bague	Deichsel ring	Anillo
11	524139014	1	Instrument panel	Cruscotto	Tableau de bord	Instrumentenbret	Tablero instrum.
12	524141523	1	Cover	Carter	Couvercle	Deckel	Tapa
13	272342200	4	Nut	Dado speciale	Ecrou	Mutter	Tuerca
14	580012968	1	Adhesive label	Adesivo	Autocollants	Abz-bild	Adesivos
15	580012967	1	Adhesive label	Adesivo	Autocollants	Abz-bild	Adesivos
16	277458400	2	Vibration damper	Piedino in gomma	Pied en gomme	Stift	Vástago
17	580012959	2	Spacer	Distanziale	Entretoise	Entfernungsstück	Separador
18	580014880	1	Adhesive label -30°	Adesivo -30°	Autocollants -30°	Abz-bild -30°	Adesivos -30°

Da matr. / Du matr. / Ab. seriennummer  
 From serial N° / Desde la matr.:

Fino a matr. / Jusqu' matr. / Bis zur serien-Nr.  
 Until serial N° / Hasta la matr.:

Ad esclusione di / À l'exclusion de  
 Mit ausnahme von / With the exception of / Excepto:

Compreso / Avec / Einschließlich  
 Including / Con:

**B846X01578X**

**B846X01579X-80X-81X-85X  
 87X-89X-91X-93X-94X-95X-97X**

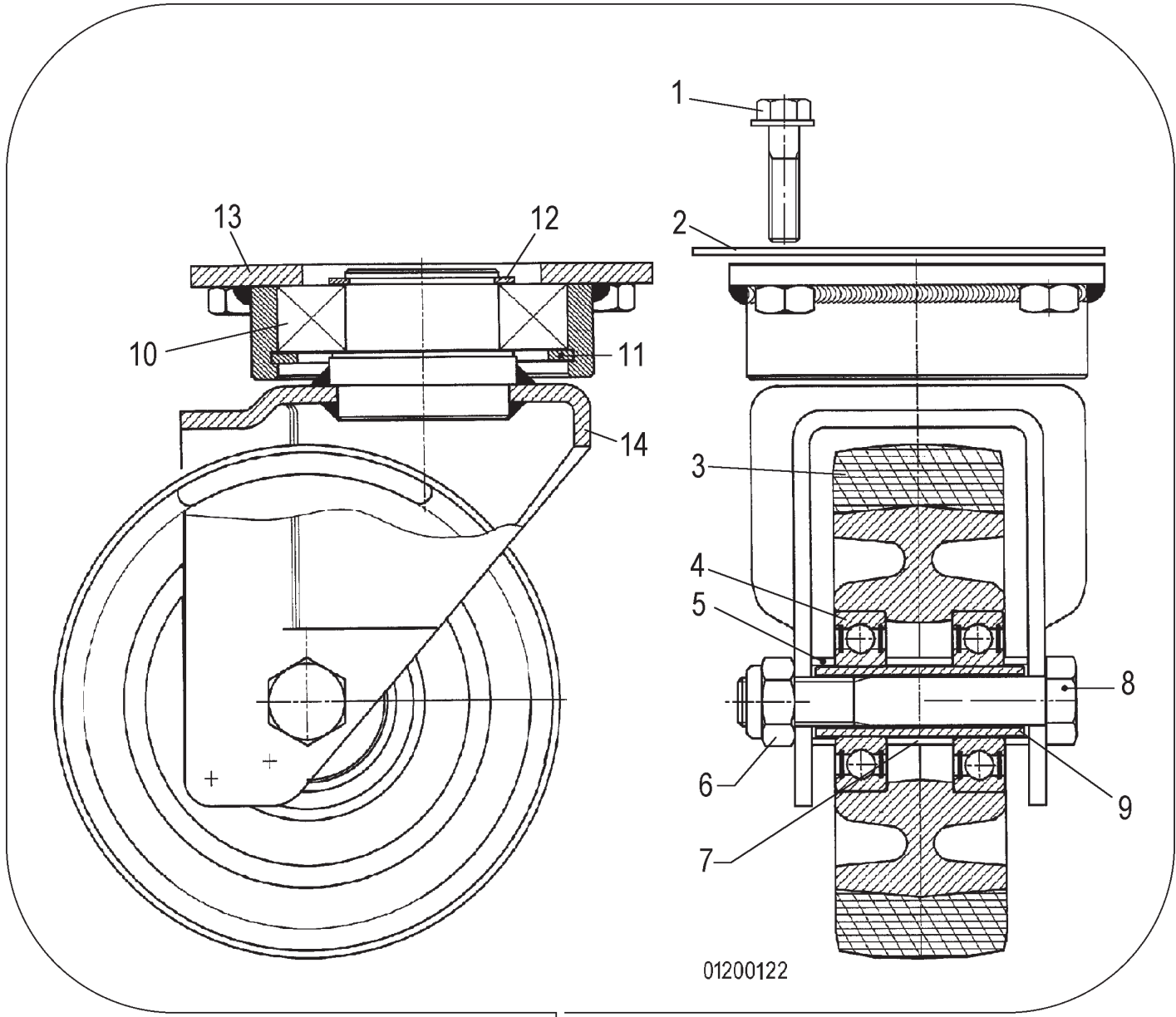

15

01200122

Da matr. / Du matr. / Ab. seriennummer  
 From serial N° / Desde la matr.:

Fino a matr. / Jusqu' matr. / Bis zur serien-Nr.  
 Until serial N° / Hasta la matr.:

Ad esclusione di / À l'exclusion de  
 Mit ausnahme von / With the exception of / Excepto:

Compreso / Avec / Einschließlich  
 Including / Con:

**B846X01401W**

REF	PART N°	Qt.	DESCRIPTION	DESCRIZIONE	DESIGNATION	BENENNUNG	DENOMINACIONES
1	580013314	4	Screw	Vite	Vis	Schraube	Tornillo
2	580013312	1	Plate	Piastra	Plaque	Platte	Placa
3	580014654	1	Wheel	Ruota	Roue	Rad	Rueda
4	022055700	2	Bearing	Cuscinetto	Roulement	Lager	Rodamiento
5	272376800	2	Spacer	Distanziale	Entretoise	Entfernungsstück	Separador
6	580014435	1	Self lock nut	Dado autobloccante	Ecrou	Mutter	Tuerca
7	580014432	1	Spacer	Distanziale	Entretoise	Entfernungsstück	Separador
8	931007915	1	Screw	Vite	Vis	Schraube	Tornillo
9	272027700	1	Bushing	Bussola	Douille	Gewindelbuchse	Casquillo
10	015120600	1	Bearing	Cuscinetto	Roulement	Lager	Rodamiento
11	580014436	1	Ring	Anello seeger	Bague	Ring	Anillo
12	500227901	1	Ring	Anello seeger	Bague	Ring	Anillo
13	580014434	1	Support	Supporto	Support	Lager	Soporte
14	580014433	1	Support	Supporto	Support	Lager	Soporte
15	580013313	1	Caster wheel ass'y	Assieme ruota piroettante	Ensemble roue	Satz rad	Grupo rueda

Da matr. / Du matr. / Ab. seriennummer  
 From serial N° / Desde la matr.:

Fino a matr. / Jusqu' matr. / Bis zur serien-Nr.  
 Until serial N° / Hasta la matr.:

Ad esclusione di / À l'exclusion de  
 Mit ausnahme von / With the exception of / Excepto:

Compreso / Avec / Einschließlich  
 Including / Con:

**B846X01401W**

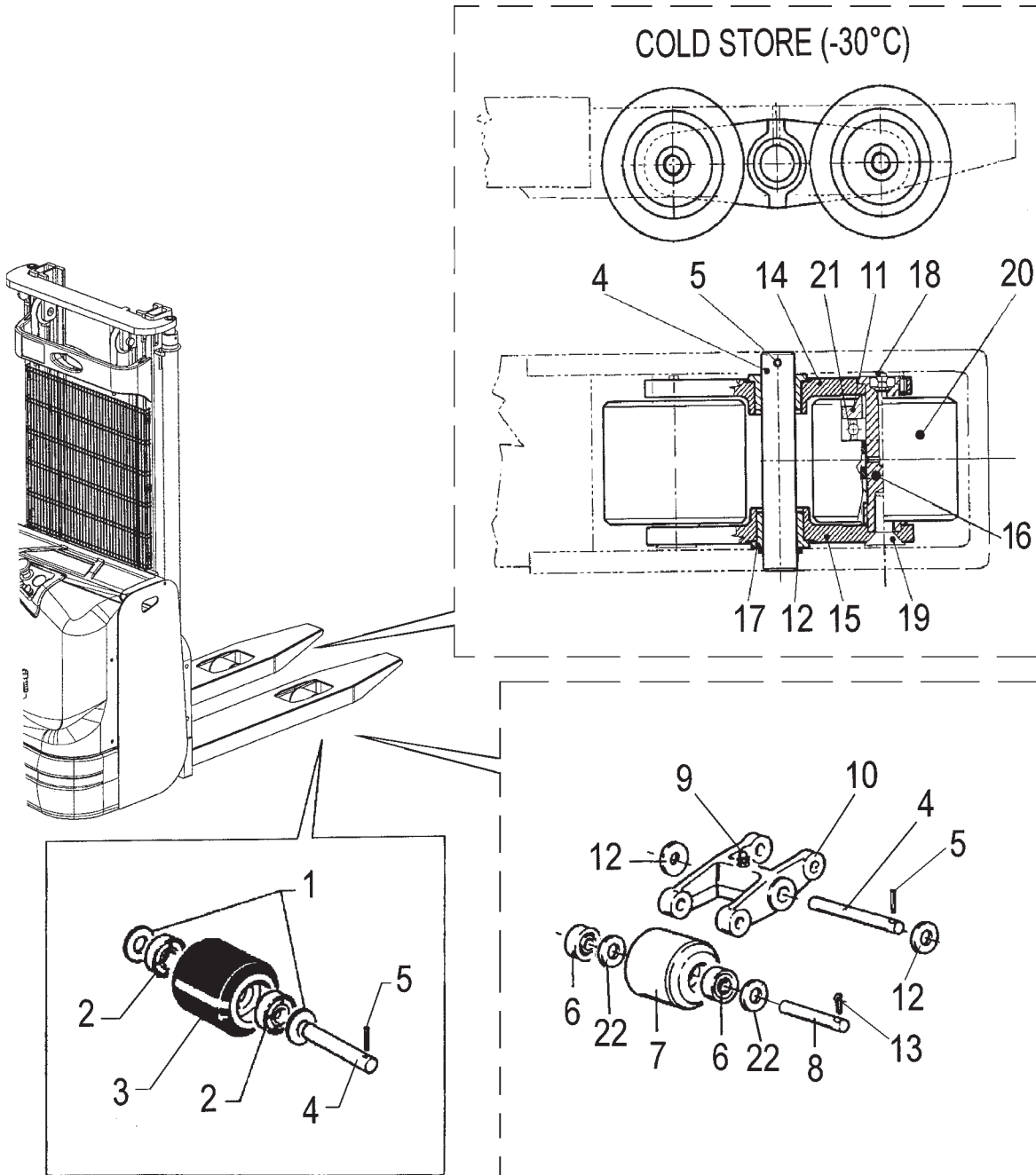

01200123

Da matr. / Du matr. / Ab. seriennummer  
 From serial N° / Desde la matr.:

Fino a matr. / Jusqu' matr. / Bis zur serien-Nr.  
 Until serial N° / Hasta la matr.:

Ad esclusione di / À l'exclusion de  
 Mit ausnahme von / With the exception of / Excepto:

Compreso / Avec / Einschließlich  
 Including / Con:

**B846X01401W**

REF	PART N°	Qt.	DESCRIPTION	DESCRIZIONE	DESIGNATION	BENENNUNG	DENOMINACIONES
1	272006400	4	Washer	Rondella	Rondelle	Scheibe	Arandela
2	272002700	4	Bearing	Cuscinetto	Roulement	Lager	Rodamiento
3	272226300	2	Roller	Rullo	Tambour	Walze	Rodillo
4	580013309	2	Pin	Perno	Goujon	Bolzen	Eje
5	449034030	2	Elastic pin	Spina elastica	Goupille elastique	Elastischer stecker	Clavija elástica
6	272023200	8	Bearing	Cuscinetto	Roulement	Lager	Rodamiento
7	272015300	4	Roller	Rullo	Tambour	Walze	Rodillo
8	272078800	4	Pin	Perno	Goujon	Bolzen	Eje
9	272008800	2	Grease fitting	Ingrassatore	Graisiseur	Schmiernippel	Engrasador
10	580013311	2	Rocker	Bilancere	Culbuteur	Kipphebel	Balancin
11	273065500	8	Seal	Guarnizione	Joint	Dichtung	Junta
12	272006400	8	Washer	Rondella	Rondelle	Scheibe	Arandela
13	449034082	4	Elastic pin	Spina elastica	Goupille elastique	Elastischer stecker	Clavija elástica
14	277548300	2	Through rocker plate	Bilancino passante	Palonnier	Pendeldurchgangsplatte	Balancin pasante
15	277548400	2	Counter. rocker plate	Bilancino svasato	Palonnier	Pendelbecher	Balancin vaciado
16	277548500	4	Axle	Perno	Goujon	Bolzen	Eje
17	273127500	4	Bushing	Boccola	Douille	Buchse	Casquillo
18	273033400	4	Grease fig.	Ingrassatore	Graisiseur	Schmiernippel	Engrasador
19	580001470	4	Screw	Vite	Vis	Schraube	Tornillo
20	277548200	4	Polyuretane wheel	Rullo in vulkollan	Roue en vulkollan	Adipren-Rolle	Rodillo poliuretano
21	273005500	8	Bearing	Cuscinetto	Roulement	Lager	Rodamiento
22	272065200	16	Washer	Rondella	Rondelle	Scheibe	Arandela

Da matr. / Du matr. / Ab. seriennummer  
 From serial N° / Desde la matr.:

Fino a matr. / Jusqu' matr. / Bis zur serien-Nr.  
 Until serial N° / Hasta la matr.:

Ad esclusione di / À l'exclusion de  
 Mit ausnahme von / With the exception of / Excepto:

Compreso / Avec / Einschließlich  
 Including / Con:

<b>B846X01401W</b>			
--------------------	--	--	--



**Suggest:**

**For more complete manuals. Please go to the home page.**

**<https://www.ebooklibonline.com>**

**If the above button click is invalid. Please download this document first, and then click the above link to download the complete manual.**

**Thank you so much for reading**



REF	PART N°	Qt.	DESCRIPTION	DESCRIZIONE	DESIGNATION	BENENNUNG	DENOMINACIONES
1	580013479	1	PU Wheel (95 Sh)	Ruota in poliuretano (95 Sh)	Roue en Vulkollan (95 Sh)	Rad (95 Sh)	Rueda Vulkollan(95 Sh)
1	580013477	1	No marking w heel (72Sh) -30°	Ruota in poliur.antitraccia (72Sh) -30°	Roue en Vulkollan (72Sh) -30°	Rad (72 Sh) -30°	Rueda Vulkollan (72Sh) -30°
1	580013478	1	PU gripped w heel (72Sh) -30°	Ruota in poliur.scolpita (72Sh) -30°	Roue en Vulkollan (72Sh) -30°	Rad (72 Sh) -30°	Rueda Vulkollan (72Sh) -30°
2	449021010	5	Washer	Rondella	Rondelle	Scheibe	Arandela
3	449001058	5	Screw	Vite	Vis	Schraube	Tornillo
4	580014438	1	Sealing ring	Anello tenuta	Joint d'etancheite	Dichtring	Junta
5	501989923	1	Stop ring	Seeger	Bague d'arret	Drahtsprengring	Anillo seguridad
6	501989907	1	Stop ring	Seeger	Bague d'arret	Drahtsprengring	Anillo seguridad
7	580014439	1	Shim	Spessore	Epaisseur	Belag	Placa
8	580014440	1	Shim	Spessore	Epaisseur	Belag	Placa
9	580014441	2	Bearing	Cuscinetto	Roulement	Lager	Rodamiento
10	580014457	1	Pinion and Ring gear	Pignone e corona conica	Pignon	Ritzel	Pinon
11	580014443	1	Gearbox	Scatola riduttore	Boite de vitesse	Wechselgetriebegeh.	Caja cambio
11	580014450	1	Gearbox -30°	Scatola riduttore -30°	Boite de vitesse -30°	Wechselgetriebegeh. -30°	Caja cambio -30°
12	272351500	2	Key	Linguetta	Linguette	Federkeil	Laminilla
13	272019300	2	Bearing	Cuscinetto	Roulement	Lager	Rodamiento
14	272006900	1	Shim	Spessore	Epaisseur	Belag	Placa
15	272040800	1	Spacer	Distanziale	Entretoise	Entfernungsstück	Separador
16	580014458	1	Kit screws	Viteria	Vis	Schrauben	Tornillos
16	580014459	1	Kit screws -30°	Viteria -30°	Vis -30°	Schrauben -30°	Tornillos -30°
17	580014445	1	Gear (R1/23,2)	Ingranaggio (R1/23,2)	Engranage (R1/23,2)	Zahnrad (R1/23,2)	Engranaje (R1/23,2)
18	272386700	1	Nut	Dado	Ecrou	Mutter	Tuerca
19	580014449	1	Gear (R1/23,2)	Ingranaggio (R1/23,2)	Engranage (R1/23,2)	Zahnrad (R1/23,2)	Engranaje (R1/23,2)
20	580013465	1	Gearbox	Gruppo riduttore	Boite de vitesse	Wechselgetriebegeh.	Caja cambio
20	580013466	1	Gearbox -30°	Gruppo riduttore -30°	Boite de vitesse -30°	Wechselgetriebegeh. -30°	Caja cambio -30°
21	580014446	1	Thrust washer	Ralla	Crapaudine	Druckscheibe	Chumacera
22	580014448	2	Greaser	Ingrassatore	Graisser	Schmierer	Engrasador

Da matr. / Du matr. / Ab. seriennummer  
 From serial N° / Desde la matr.:

Fino a matr. / Jusqu' matr. / Bis zur serien-Nr.  
 Until serial N° / Hasta la matr.:

Ad esclusione di / À l'exclusion de  
 Mit ausnahme von / With the exception of / Excepto:

Compreso / Avec / Einschließlich  
 Including / Con:

**B846X01401W**

**<https://www.ebooklibonline.com>**

Hello dear friend!

Thank you very much for reading.

Enter the link into your browser.

The full manual is available for immediate download.

**<https://www.ebooklibonline.com>**