

Part No: 272487600 (06/2000)

Parts Manual
Elenco Ricambi
Manuel des Pièces de Rechange
Ersatzteilkatalog
Manual de Repuestos

CE

MP 20X

Yale 

Specify the following information when ordering spare parts: Zum Bestellen von Ersatzteilen bitte folgende Angaben machen:

- **truck model;**
- truck serial number;
- **table N°;**
- *part number of required component;*
- **quantity;**
- *part description*

- **Staplertyp;**
- Seriennummer der Maschine;
- **Tafel-Nr.;**
- *Best. Nr. des erforderlichen Teils;*
- **Erforderliche Stückzahl;**
- *Bezeichnung des erforderlichen Teils.*

Per ordinare parti di ricambio specificare:

- **tipo della macchina;**
- *matricola della macchina;*
- **n° della tavola;**
- *numero di codice del particolare richiesto;*
- **quantità di particolari richiesti;**
- *denominazione del particolare richiesto.*

Para solicitar los repuestos especificar:

- **tipo de la máquina;**
- *matrícula de la máquina;*
- **n° de la máquina;**
- *número de código de la pieza solicitada;*
- **cantidad de piezas solicitadas;**
- *denominación de la pieza solicitada.*

Pour les commander les pièces détachées veuillez préciser:

- **type machine;**
- *n° matricule;*
- **n° plan;**
- *n° code de la pièce;*
- **nombre de pièces;**
- *désignation de la pièce.*

Part Sheet index - Indice delle tavole - Index des tables - Tafelverzeichnis - Indice de tablas

PART SHEET 1.A PAGE N° 4	PART SHEET 2.A PAGE N° 6	PART SHEET 3.A PAGE N° 8
COVERS	ADHESIVE LABELS	FRAME BATTERY VERTICAL REMOVAL
CARTER	TARGHETTE ADESIVE	TELAIO BATTERIA ESTRAZIONE VERTICALE
COUVERCLE	AUTOCOLLANTS DE SIGNALISATION	CHASSIS BATTERIE VERTICAL EXTRACTION
DECKEL	ABZ.-BILD	BATTERIEWECHSEL KONVENTIONELLE BATTERIE ENDNHAME
TAPAS	ADESIVOS DE AVISO	BASTIDOR BATERIA EXTRACCION VERTICAL
PART SHEET 4.A PAGE N° 10	PART SHEET 5.A PAGE N° 14	PART SHEET 6.A PAGE N° 16
FRAME BATTERY LATERAL REMOVAL	SUPPORTS AND DRIVE UNIT SUSPENSION SYSTEM	SUPPORTS AND CASTER WHEELS
TELAIO BATTERIA ESTRAZIONE LATERALE	SUPPORTI E MOLLEGGIO RIDUTTORE	SUPPORTI E RUOTE PIROETTANTI
CHASSIS BATTERIE LATERALE EXTRACTION	SUPPORTS ET GROUPE SUSPENSION DU MOTO-REDUCTEUR	SUPPORTS ET ATTELAGE
BATTERIEWECHSEL SEITLICHER	LAGERN UND CEFEDERTE EINRICHTUNG DER ANTRIEBS EINHEIT	LAGERN UND RÄDER
BASTIDOR BATERIA EXTRACCION LATERAL	SOPORTES Y GRUP SUSPENSION DEL MOTO-REDUCTOR	SOPORTES Y RUEDAS
PART SHEET 7.A PAGE N° 18	PART SHEET 8.A PAGE N° 20	PART SHEET 9.A PAGE N° 22
LOAD WHEELS	TRACTION UNIT	TRACTION MOTOR
RUOTE DI CARICO	GRUPPO TRAZIONE	MOTORE TRAZIONE
ATTELAGES	GROUPE DE TRACTION	MOTEUR TRACTION
RÄDER	ZUGAGGREGAT	ZUGMOTOR
RUEDAS	GRUPO DE TRACCION	MOTOR DE TRACCION
PART SHEET 10.A PAGE N° 24	PART SHEET 11.A PAGE N° 26	PART SHEET 12.A PAGE N° 28
ELECTR. MAGNETIC BRAKE	DRAWBAR CONTROL BOX	DISTRIBUTOR
FRENO ELETTROMAGNETICO	TIMONE SCATOLA COMANDI	CENTRALINA IDRAULICA
FREIN ELETTROMAGN.	BARRE BOITE DE COMMANDE	DISTRIBUTEUR
ELEKTROMAGN. BREMSE	DEICHEL STEUERUNGSBUCHSE	STEUERUNG
FRENO ELECTROM.	DIRECCION DE MANDOS	DISTRIBUIDOR

Part Sheet index - Indice delle tavole - Index des tables -Tafelverzeichnis - Indice de tablas

PART SHEET 13.A PAGE N° 30	PART SHEET 14.A PAGE N° 32	PART SHEET 15.A PAGE N° 33
HYDRAULIC SYSTEM	WIRING DIAGRAM	SHEATH DIAGRAM
IMPIANTO IDRAULICO	SCHEMA COLLEGAMENTO CAVI DI POTENZA	SCHEMA COLLEGAMENTO GUAINA
INSTALLATION HYDRAULIQUE	DIAGRAMME LIAISON CABLE ELECTRIQUE	DIAGRAMME LIAISON GAINES
HYDRAULIKANLAGE	ELEKTRISCHEANLAGEPLAN	MONTELANLAGEPLAN
INSTALACION HIDRAULICA	ESQUEMA CONEXION CABLE POTENCIA	ESQUEMA CONEXION VAINA
PART SHEET 16.A PAGE N° 34	PART SHEET 17.A PAGE N° 35	PART SHEET 18.A PAGE N° 36
ELECTRIC DIAGRAM	CONSOLE ADAPTER	CONTACTS,CONNECTORS,TOOLS
SCHEMA ELETTRICO	ADATTATORE PER CONSOLLE	CONTATTI,CONNETTORI,UTENSILI
SCHEMA ELECTRIQUE	ADAPTATEUR POUR CONSOLE	CONNECTEURS,CONTACTS,OUTILS
SCHALTPLAN	ADAPTER FÜR KONSOLLE	KONNEKTORS,KONTAKTS,WERKZEUG
ESQUEMA ELECTRICO	ADAPTADOR POR CONSOLA	CONTACTO,CONECTOR,UTENSILIO
PART SHEET 19.A PAGE N° 38	PAGE N° 40	
HYDRAULIC DIAGRAM	NUMERICAL INDEX	
SCHEMA IDRAULICO	INDICE NUMERICO	
SCHEMA HYDRAULIQUE	INDEX GENERAL	
HYDRAULIKPLAN	ALGEMEINER INDEX	
ESQUEMA HIDRAULICO	INDICE GENERAL	

<https://www.ebooklibonline.com>

Hello dear friend!

Thank you very much for reading.

Enter the link into your browser.

The full manual is available for immediate download.

<https://www.ebooklibonline.com>

COVERS
CARTER
COUVERCLE
DECKEL
TAPAS

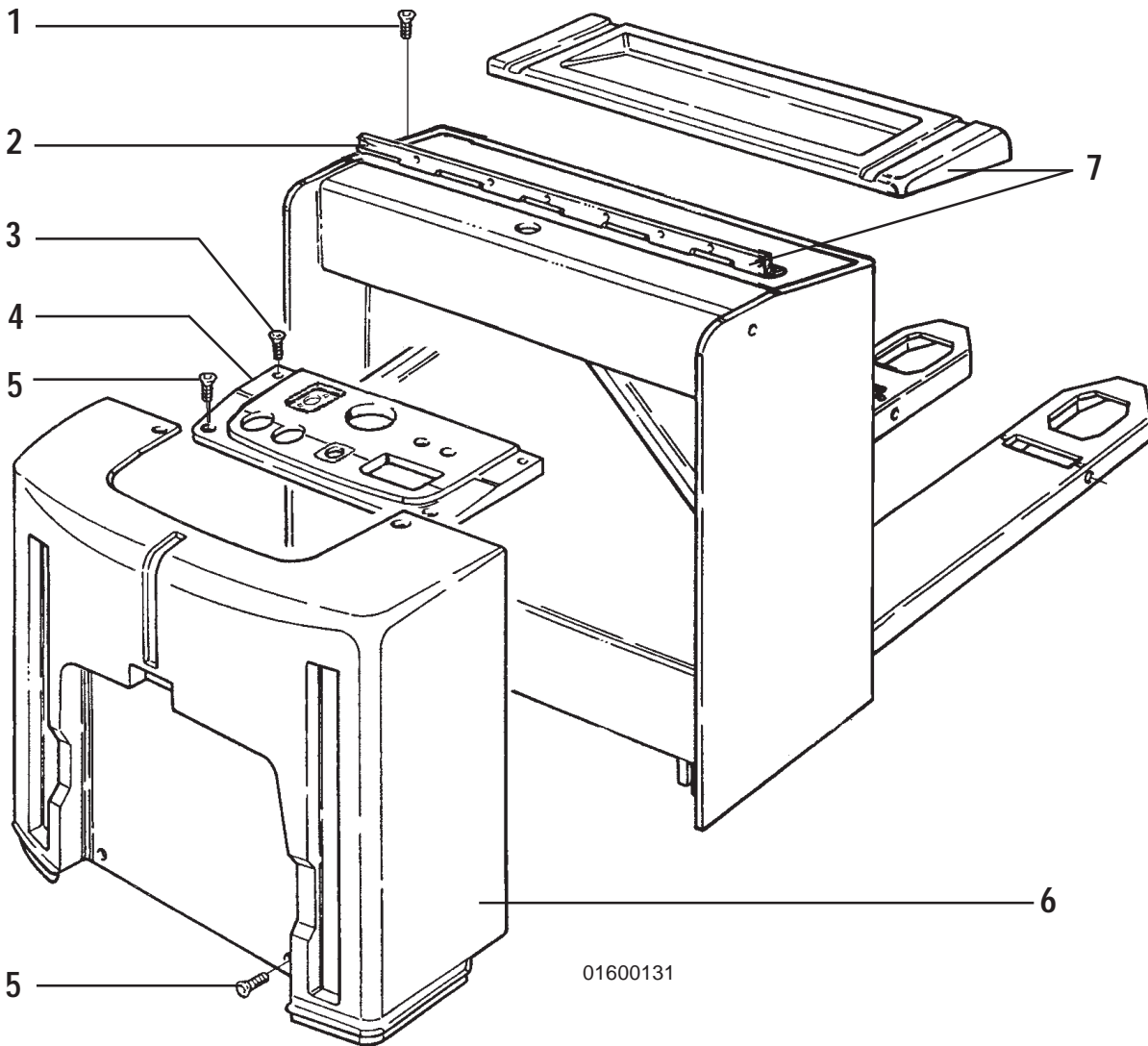

Da matr. / Du matr. / Ab. seriennummer
From serial N° / Desde la matr.:

Fino a matr. / Jusqu' matr. / Bis zur serien-Nr.
Until serial N° / Hasta la matr.:

Ad esclusione di / A l'exclusion de
Mit ausnahme von / With the exception of / Excepto:

Compreso / Avec / Einschließlich
Including / Con:

B843X02152X



COVERS
CARTER
COUVERCLE
DECKEL
TAPAS

Truck Model
Carrello Tipo
Chariot Modele
Staplertyp
Tipo de carretilla

REF	PART N°	Qt.	DESCRIPTION	DESCRIZIONE	DESIGNATION	BENENNUNG	DENOMINACIONES
1	449007013	6	Screws	Vite	Vis	Schrauben	Tornillo
2	272470400	1	Hinge	Cerniera	Charniere	Scharnier	Charnela
3	272033100	2	Screws	Vite	Vis	Schrauben	Tornillo
4	580015427	1	Instrumental panel	Cruscotto	Tableau de bord	Instrumentenbret	Tablero instrum.
5	272304100	4	Screws	Vite	Vis	Schrauben	Tornillo
6	272378500	1	Cover	Carter	Couvercle	Deckel	Tapa
7	580016869	1	Battery cover	Coperchio batteria	Couvercle batterie	Batterie deckel	Cubierta bateria

Da matr. / Du matr. / Ab. seriennummer
From serial N° / Desde la matr.:

Fino a matr. / Jusqu' matr. / Bis zur serien-Nr.
Until serial N° / Hasta la matr.:

Ad esclusione di / À l'exclusion de
Mit ausnahme von / With the exception of / Excepto:

Compreso / Avec / Einschließlich
Including / Con:

B843X02152X



Suggest:

For more complete manuals. Please go to the home page.

<https://www.ebooklibonline.com>

If the above button click is invalid. Please download this document first, and then click the above link to download the complete manual.

Thank you so much for reading

ADESIVE LABELS
TARGHETTE ADESIVE
AUTOCOLLANTS DE SAGNALISATION
ABZ.BILD
ADESIVOS DE AVISO

REF	PART N°	Qt.	DESCRIPTION	DESCRIZIONE	DESIGNATION	BENENNUNG	DENOMINACIONES
1	580012968	1	Adhesive label	Adesivo	Autocollants	Abz-bild	Adesivos
2	524139322	1	Adhesive label	Adesivo	Autocollants	Abz-bild	Adesivos
3	580012967	1	Adhesive label	Adesivo	Autocollants	Abz-bild	Adesivos
4	272213500	2	Adhesive label	Adesivo	Autocollants	Abz-bild	Adesivos
5	272213300	2	Adhesive label	Adesivo	Autocollants	Abz-bild	Adesivos
6	272213400	2	Adhesive label	Adesivo	Autocollants	Abz-bild	Adesivos
7	580013471	2	Adhesive label	Adesivo	Autocollants	Abz-bild	Adesivos
8	580014880	1	Adhesive label -30°C	Adesivo -30°C	Autocollants -30°C	Abz-bild -30°C	Adesivos -30°C
9	272213600	1	Adhesive label	Adesivo	Autocollants	Abz-bild	Adesivos
10	272213200	2	Adhesive label	Adesivo	Autocollants	Abz-bild	Adesivos
11	580014086	1	Adhesive label	Adesivo	Autocollants	Abz-bild	Adesivos
12	272472800	1	Adhesive label	Adesivo	Autocollants	Abz-bild	Adesivos
13	502157201	1	Adhesive label	Adesivo	Autocollants	Abz-bild	Adesivos

Da matr. / Du matr. / Ab. seriennummer
From serial N° / Desde la matr.:

Fino a matr. / Jusqu' matr. / Bis zur serien-Nr.
Until serial N° / Hasta la matr.:

Ad esclusione di / À l'exclusion de
Mit ausnahme von / With the exception of / Excepto:

Compreso / Avec / Einschließlich
Including / Con:

B843X02152X

FRAME BATTERY VERTICAL REMOVAL
TELAIO BATTERIA ESTRAZIONE VERTICALE
CHASSIS BATTERIE VERTICAL EXTRACTION
BATTERIEWECHSEL KONVETIONELLE BATTERIE ENDNHAME
BASTIDOR BATERIA EXTRACCION VERTICAL

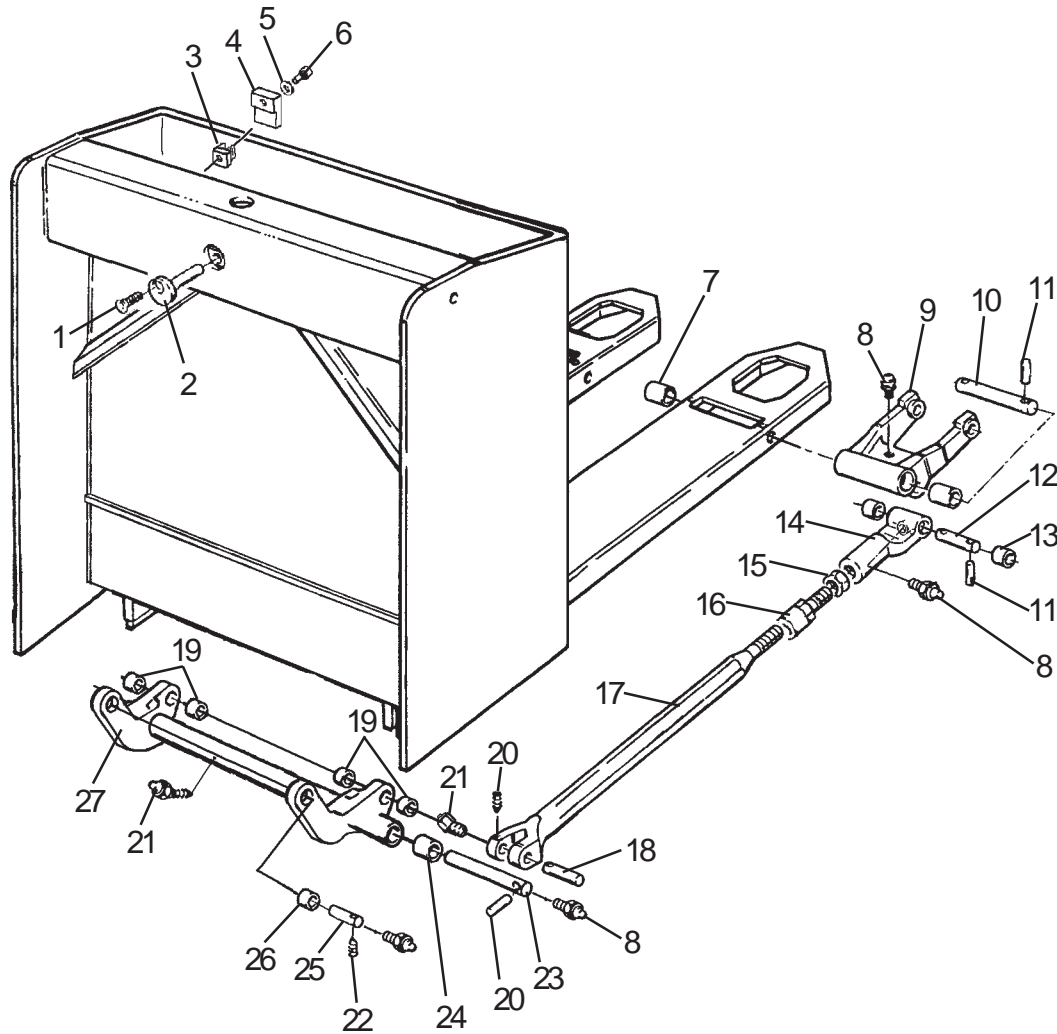

01600138

Da matr. / Du matr. / Ab. seriennummer
From serial N° / Desde la matr.:

Fino a matr. / Jusqu' matr. / Bis zur serien-Nr.
Until serial N° / Hasta la matr.:

Ad esclusione di / A l'exclusion de
Mit ausnahme von / With the exception of / Excepto:

Compreso / Avec / Einschließlich
Including / Con:

B843X02152X

<https://www.ebooklibonline.com>

Hello dear friend!

Thank you very much for reading.

Enter the link into your browser.

The full manual is available for immediate download.

<https://www.ebooklibonline.com>